

- EN** Installation / User Instructions / Warranty
- FR** Instructions de montage / Mode d'emploi / Garantie
- ES** Instrucciones de montaje / Manejo / Garantía

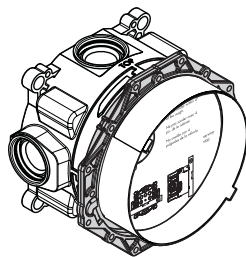

**iBox Universal
Plus Rough**
01850181

Important Note

This rough valve must be finished with a trim kit. An automatically compensating valve is created when a shower or tub/shower valve trim kit is installed. Both pressure balancing (Type P) and Thermostatic (Type T) trim kits are available. Please refer to the chart below:

Trim Kit	Style	Type	Trim Kit	Style	Type
46751xx1	AXOR Edge	T	16821xx1	AXOR Montreux	T
46750xx1	AXOR Edge	T	16508xx1	AXOR Montreux	P
46761xx1	AXOR Edge	T	16816xx1	AXOR Montreux	T
46760xx1	AXOR Edge	T	16824xx1	AXOR Montreux	T
46461xx1	AXOR Edge	P	04779xx0	Joleena	P
46460xx1	AXOR Edge	P	15762xx1	ShowerSelect	T
36714xx1	AXOR ShowerSelect	T	15763xx1	ShowerSelect	T
36714xx1	AXOR ShowerSelect	T	15744xx1	ShowerSelect	T
36705xx1	AXOR ShowerSelect	T	15742xx1	ShowerSelect	T
36707xx1	AXOR ShowerSelect	T	15712xx1	Ecostat Square	T
36722xx1	AXOR ShowerSelect	T	15714xx1	Ecostat Square	T
36723xx1	AXOR ShowerSelect	T	15724xx1	Ecostat Square	P
10700xx1	AXOR Starck	T	15757xx1	Ecostat S	T
10720xx1	AXOR Starck	T	15758xx1	Ecostat S	T
10407xx1	AXOR Starck	P	15739xx1	Ecostat S	P
10715xx1	AXOR Starck	P	15707xx1	Ecostat E	T
12715xx1	AXOR Starck Organic	T	15708xx1	Ecostat E	T
12716xx1	AXOR Starck Organic	T	15718xx1	Ecostat E	P
12711xx1	AXOR Starck Organic	T	15727xx1	Ecostat Classic	T
39700xx1	AXOR Citterio	T	15728xx1	Ecostat Classic	T
39720xx1	AXOR Citterio	T	15769xx1	Ecostat Classic	P
39414xx1	AXOR Citterio	P	04230xx0	Ecostat S	T
39716xx1	AXOR Citterio	T	04231xx0	Ecostat S	T
39711xx1	AXOR Citterio	T	04233xx0	Ecostat S	P
37405xx1	AXOR Citterio M	T	04447xx0	Ecostat S	P
34725xx1	AXOR Citterio M	T	04352xx0	Ecostat S/E	T
34808xx1	AXOR Citterio M	P	04353xx0	Ecostat S/E	T
34714xx1	AXOR Citterio M	T	04355xx0	Ecostat S/E	P
11732xx1	AXOR Urquiola	T	04448xx0	Ecostat S/E	P
11733xx1	AXOR Urquiola	T	15752xx1	Ecostat Classic	T
11408xx1	AXOR Urquiola	P	15753xx1	Ecostat Classic	T
11731xx1	AXOR Urquiola	T	15404xx1	Ecostat Classic	P
18745xx1	AXOR Massaud	T	04449xx0	Ecostat Classic	P
18750xx1	AXOR Massaud	T	04441xx0	Commercial	P
18978xx1	AXOR Massaud	P	04496xx0	Commercial	P
18741xx1	AXOR Massaud	T	15775xx1	PuraVida	T
38418xx1	AXOR Uno	P	15771xx1	PuraVida	T
38715xx1	AXOR Uno	T	15407xx1	PuraVida	P
16801xx1	AXOR Montreux	T			

Contents

English

Installation Considerations	3
Technical Information	6
Service Stops	7
Replacement Parts	7
Installation Options	8
Adjust the fixing ring	10
Installation tip	11
Installation	12
Mixing Valve Trim Kits	18
Symbols used	21
Suggested Installations	23

Français

À prendre en considération pour l'installation	4
Données techniques	6
Butées d'arrêt d'isolation	7
Pièces détachées	7
Options d'installation	8
Ajuster l'anneau de fixation	10
Exemple de montage	11
Installation	12
Jeu de Garniture	19
Symbols used	21
Suggestions d'installation	23

Español

Consideraciones para la instalación	5
Datos técnicos	6
Cierres de servicio	7
Repuestos	7
Opciones de instalación	8
Ajuste el anillo de fijación	10
Recomendación	11
Instalación	12
Juegas de piezas exteriores	20
Symbols used	21
Sugerencias de instalación	23

Installation Considerations

⚠ Know in advance what type of trim kit is to be used. Installation requirements vary. Additional valve(s) may be required. Please refer to page 18.

- Some municipalities do not permit installations that allow the use of two or more shower functions simultaneously. Please know and follow all applicable local plumbing codes.
- For best results, Hansgrohe recommends that this unit be installed by a licensed, professional plumber.
- Please read over these instructions thoroughly before beginning installation. Make sure that you have all tools and supplies needed to complete the installation.
- Do not remove the plastic installation box from the valve.

⚠ For correct function of the valve, the hot supply must be plumbed to the hot inlet (left) and the cold supply must be plumbed to the cold inlet (right).

- The connections on the valve are $\frac{3}{4}$ NPT. $\frac{1}{2}$ NPT lines may be used if suitable for the installation. The installer must provide $\frac{3}{4}$ - $\frac{1}{2}$ adapters.

⚠ The outside surface of the finished wall must fall between the "min" and "max" markings on the iBox.

⚠ Important!

- The cartridge is included with the trim kit. The cartridge will vary, according to the type of trim kit.
- The cartridge has an integrated high temperature limit stop which may be reset to comply with local plumbing codes.
- To prevent scald injury, the maximum output temperature of the shower valve must be no

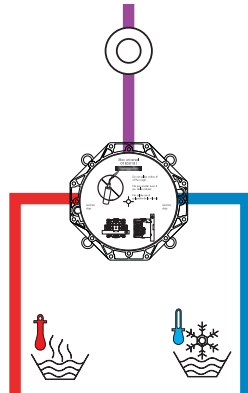
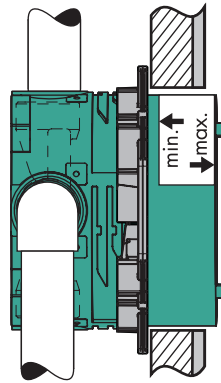

higher than 120°F (49°C). In Massachusetts the maximum output temperature of the shower valve can be no higher than 112°F (44°C).

- Protect the rough from freeze damage. In the event of freezing temperatures, drain the pipes.

À prendre en considération pour l'installation

⚠ **Déterminez à l'avance le type de jeu de garniture à utiliser. Les exigences d'installation varient. Il pourra être nécessaire d'utiliser des robinets supplémentaires. S'il vous plaît se référez à page 19.**

- Pour de meilleurs résultats, Hansgrohe recommande que ce produit soit installé par un plombier professionnel licencié.
- Veuillez lire attentivement ces instructions avant de procéder à l'installation. Assurez-vous de disposer de tous les outils et du matériel nécessaires pour l'installation.
- Ne retirez pas la boîte d'installation en plastique du robinet.

⚠ **Pour que le robinet fonctionne correctement, la conduite d'alimentation de l'eau chaude doit être installée dans l'orifice d'arrivée prévu pour l'eau chaude (gauche), et la conduite d'eau froide doit être installée dans l'orifice d'arrivée prévu pour l'eau froide (droite).**

- **En option:** Installez le(s) ½ po adaptateur(s) (non compris).

⚠ **Installez le robinet de façon à ce que la surface extérieure du mur fini se trouve entre les lignes « minimum » et « maximum ».**

⚠ Avis

- La cartouche est comprise avec le jeu de garniture. La cartouche variera selon le type de jeu de garniture.
- La cartouche dispose d'une butée de limite d'eau chaude qui peut être réglée de façon à satisfaire aux codes de plomberie locaux.
- Pour empêcher des blessures par ébullition, la température de sortie

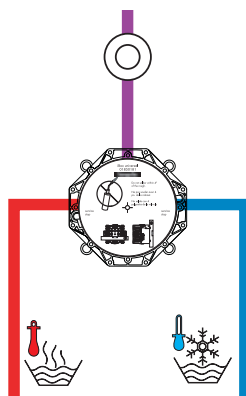
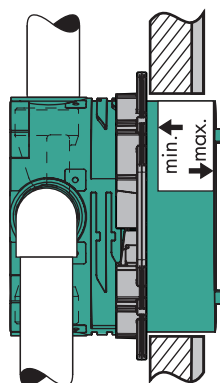

maximale du robinet de douche ne doit pas excéder 120°F (49°C). Au Massachusetts, la température de sortie maximale du robinet de douche ne doit pas excéder 112°F (44°C).

- Protégez la pièce intérieure des dommages occasionnés par le gel. Vidangez les tuyaux si les températures sont au-dessous du point de congélation.

Consideraciones para la instalación

⚠ **Conozca de antemano qué tipo de juego de pieza exterior va a usar. Los requisitos de instalación varían. Pueden requerirse una o más válvulas adicionales. Refiérase por favor para página 20.**

- Para obtener mejores resultados, Hansgrohe recomienda que la instalación de esta unidad esté a cargo de un plomero profesional matriculado.
- Antes de comenzar la instalación, lea estas instrucciones detenidamente. Asegúrese de tener las herramientas y los insumos necesarios para completar la instalación.
- No retire la caja de instalación plástica de la válvula.

⚠ **Para que la válvula funcione correctamente, el suministro de agua caliente se debe conectar a la entrada de agua caliente (izquierdo) y el de agua fría a la entrada de agua fría (derecho).**

- **Opcional:** Instale los ½" adaptadores (no incluidos).

⚠ **Instale la válvula de modo que la superficie exterior de la pared terminada quede entre las marcas "min" y "max".**

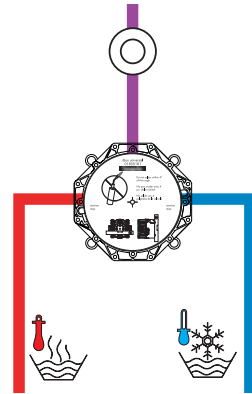
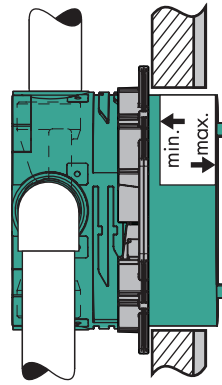

⚠ **Aviso**

- El cartucho está incluido en el juego de la pieza exterior. El cartucho varía de acuerdo al tipo de juego de pieza exterior.
- El cartucho tiene un cierre de límite de alta temperatura que se puede reajustar para cumplir los códigos de plomería locales.
- Al prevenir escaldada herida, la temperatura de salida máxima de la válvula de chaparrón

no debe ser más alto que 120°F (49°C). En Massachusetts: la temperatura de salida máxima de la válvula no puede ser más alto que 112°F (44°C).

- Proteja la pieza interior contra los daños por congelamiento. En caso de temperaturas de congelamiento, drene las cañerías.

Technical Information / Données techniques / Datos técnicos

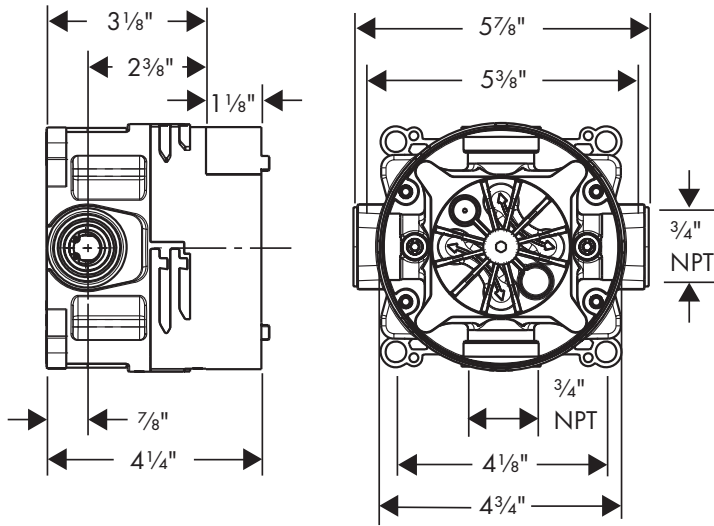

Recommended water pressure	Pression de service conseillée	Presión recomendada en servicio	15 - 75 PSI (0.1-0.5 MPa)
Max. water pressure	Pression de service max.	Presión máximo en servicio	145 PSI (1 MPa)
Recommended hot water temp.	Température recommandée	Temp. recomendada del agua caliente	120° - 140° F (48° - 60° C)
Max. hot water temp.	Température max. d'eau chaude	Temperatura max. del agua caliente	158° F (70° C)
Max. flow rate @ 44 PSI (0.3 MPa)	Capacité nominale @ 44 PSI (0.3 MPa)	Caudal máximo @ 44 PSI (0.3 MPa)	
Thermostatic mixer	Mitigeur thermostatique	Mezclador termostático	13 GPM (49.2 L/min)
Thermostat with volume control	Mitigeur thermostatique avec contrôle de débit	Mezclador termostático con llave de paso	6.0 GPM (22.7 L/min)
Thermostat with volume control / diverter	Mitigeur thermostatique avec contrôle de débit / inverseur	Mezclador termostático con llave de paso / distribuidor	7.0 GPM (26.5 L/min)
Pressure balance valve	Mitigeur équilibrage de pression	Válvula de presión balanceada	5.5 GPM (20.8 L/min)
Pressure balance valve with diverter	Mitigeur équilibrage de pression avec inverseur	Válvula de presión balanceada y distribuidor	4.5 GPM (17 L/min)
Connections	Connexions	Conexiones	¾" NPT female cold right / hot left

*Please know and follow all applicable local plumbing codes when setting the temperature on the water heater.

* Vous devez connaître et respecter tous les codes de plomberie locaux applicables pour le réglage de la température du chauffe-eau.

*Debe conocer y cumplir todos los códigos locales aplicables para ajustar la temperatura del calentador de agua

Service Stops / Butées d'arrêt d'isolation / Cierres de servicio

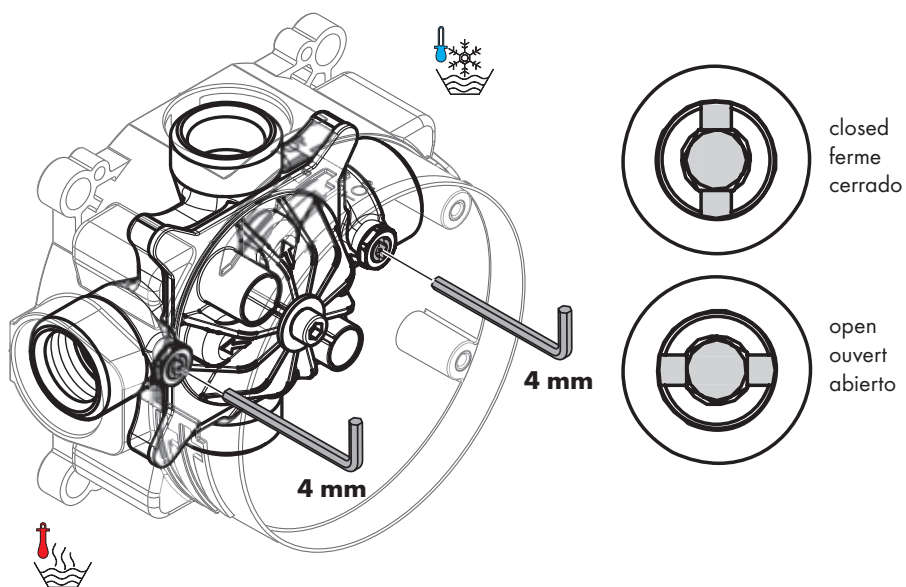

Replacement Parts / Pièces détachées / Repuestos

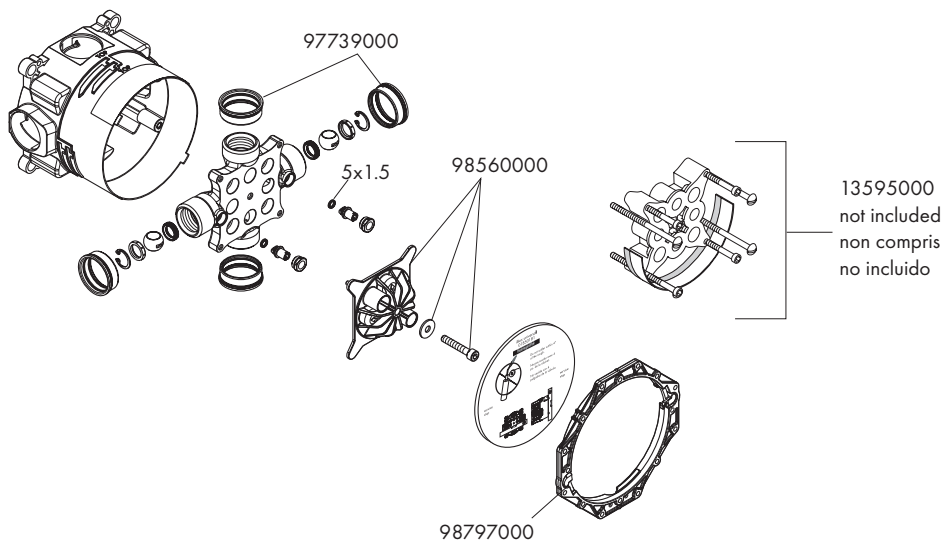

Installation Options / Options d'installation / Opciones de instalación

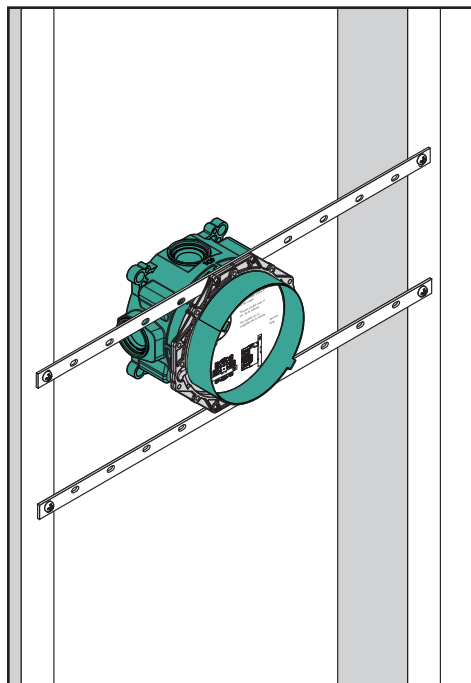
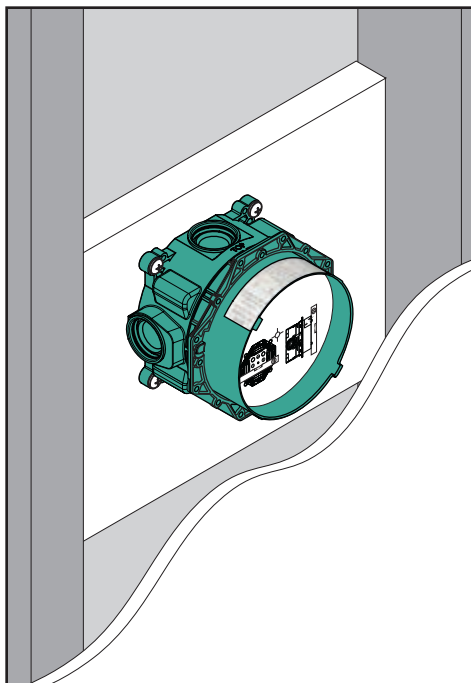

English

It is possible to support the iBox Plus Universal using a stringer and screws (not included).

The valve may also be supported using installation kit 96615000 (not included).

Français

C'est possible de soutenir le robinet utilisant un plaque arrière et vis (pas inclus).

C'est aussi possible à soutenir le robinet utilisant set d'installation 96615000 (pas inclus).

Español

Es posible apoyar la válvula que utiliza una placa trasera y tornillos (no incluido).

Es también posible a apoyar la válvula que utiliza set de instalación 96615000 (no incluido).

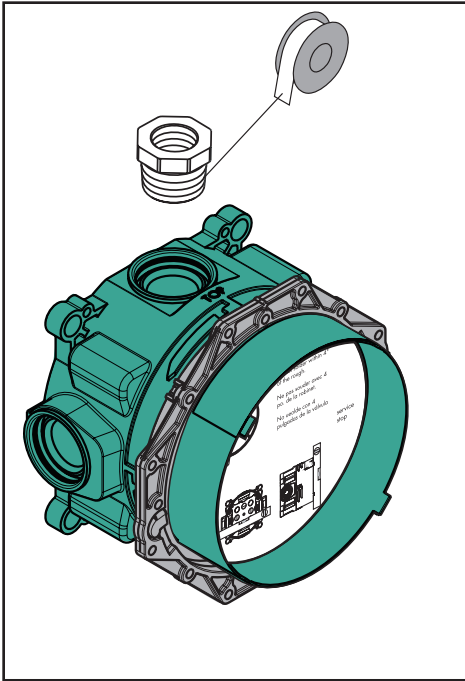

English

Optional: If using $\frac{1}{2}$ " lines, install $\frac{3}{4}$ "- $\frac{1}{2}$ " NPT adapters (not included).

Tighten the adapter fully before installing the $\frac{1}{2}$ " pipe.

Français

En option: Installez le(s) $\frac{1}{2}$ po adaptateur(s) (non compris).

Serrez l'adaptateur complètement avant d'installer le $\frac{1}{2}$ po tuyau.

Español

Opcional: Instale los $\frac{1}{2}$ " adaptadores (no incluidos).

Apriete el adaptador completamente antes de instalar el tubo de $\frac{1}{2}$ ".

Adjust the fixing ring / Ajuster l'anneau de fixation / Ajuste el anillo de fijación

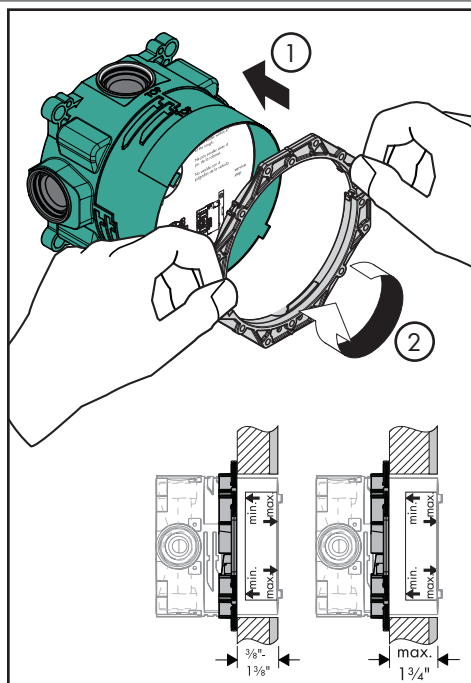
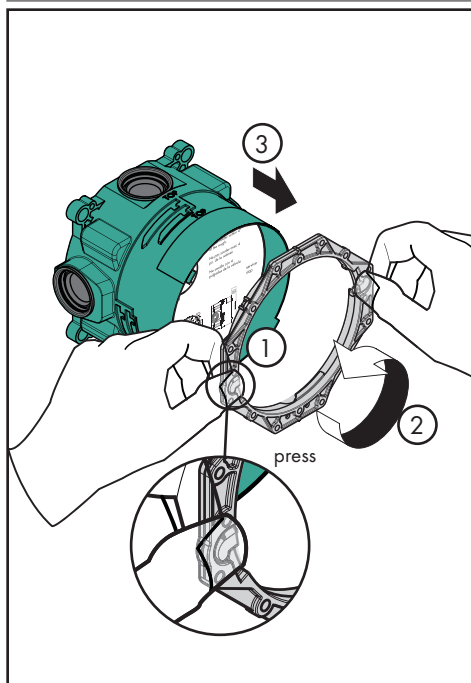

English

The fixing ring may be repositioned to accommodate different wall thicknesses.

Français

L'anneau réparant pourrait être repositionné pour accommoder les épaisseurs de mur différentes.

Español

El anillo que fija puede ser recolado acomodar los espesores diferentes de pared.

Installation tip / Exemple de montage / Recomendación

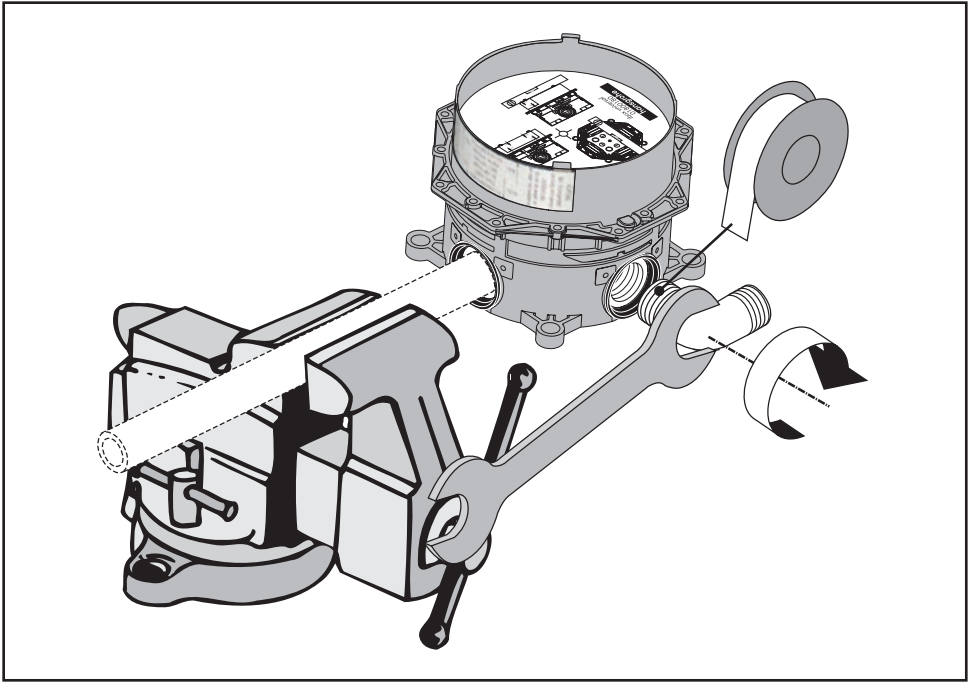

English

When installing the supply elbows, hold the iBox steady using a pipe and a vise.



Do not solder within 4" of the rough, or damage to the rough may result.

Français

Pour monter les différents raccords, on peut fixer l'iBox grâce à un tuyau et un étau.



Aucune soudure ne peut être réalisée si la pièce intérieure se trouve à moins de 4 po sans quoi des dommages pourraient survenir.

Español

Para enroscar los codos de conexión, fijar el iBox universal mediante un trozo de tubería en un tornillo de banco.



No suelde a menos de 4 pulg. de la pieza interior puesto que puede dañarla.

Installation / Installation / Instalación

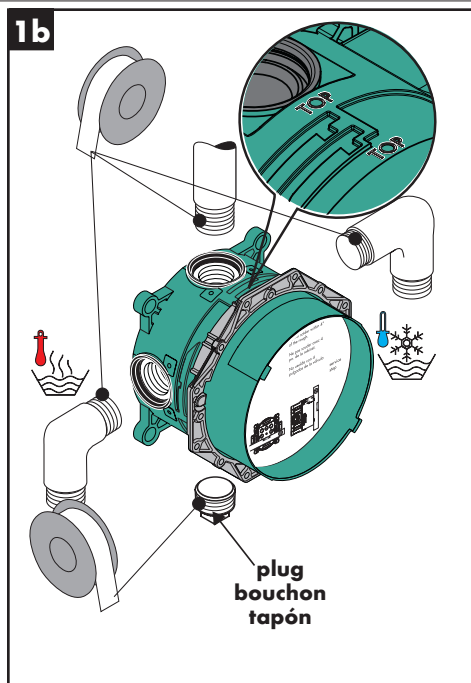
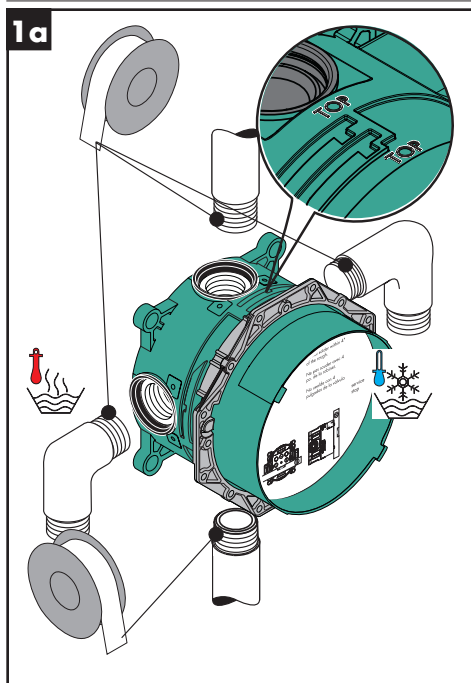

English

Install the valve so that the "top" marking faces upward.

Install the hot and cold supplies on the hot inlet (left horizontal side) and cold inlet (right horizontal side).

Install the outlet line(s).

If an outlet is not to be used, seal it with a 3/4" plug (not included).

Français

Installez le robinet de façon à ce que les faces de marquage soient dirigées vers le haut.

Raccordez les conduites d'alimentation de l'eau chaude et de l'eau froide aux orifices d'arrivée chaude (l'horizontale latérale gauche) et froide (l'horizontale latérale droite).

Installez le(s) conduite(s) de sortie.

Si vous utilisez seulement un orifice de sortie, scellez l'orifice de sortie inutilisé à l'aide d'un bouchon de 3/4 po (non compris).

Español

Instale la válvula de modo que la marca "top" mire hacia arriba.

Instale los suministros de agua caliente y fría en las entradas caliente (lado horizontal izquierdo) y fría (lado horizontal derecho).

Instale una o dos líneas en las tomas.

Si usa sólo una toma, selle la toma sin usar con un tapón de 3/4 pulg. (no incluido).

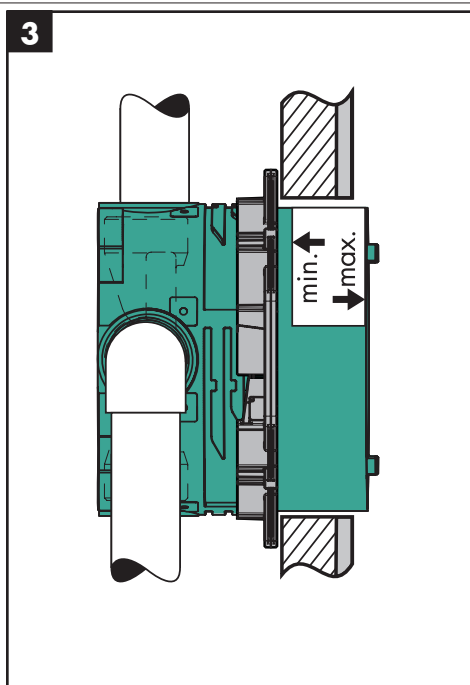
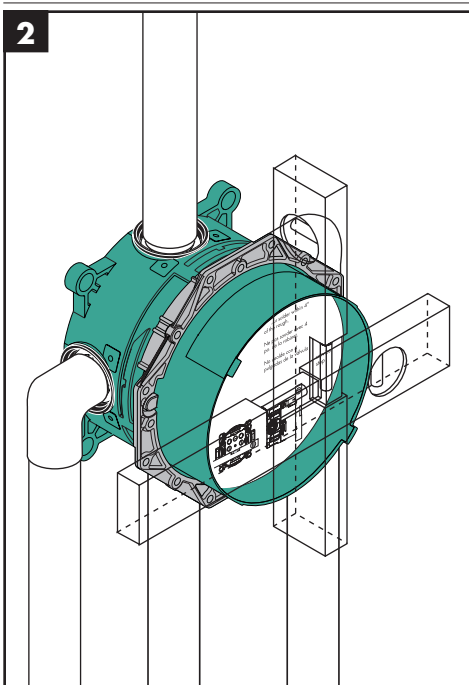

English

- ⚠ **Do not solder within 4" of the rough, or damage to the rough may result.**

Make sure that the valve is level.

Install the valve so that the outside surface of the finished wall falls between the "min" and "max" markings.

Français

- ⚠ **Aucune soudure ne peut être réalisée si la pièce intérieure se trouve à moins de 4 po sans quoi des dommages pourraient survenir.**

Assurez-vous que le robinet est de niveau.

Installez le robinet de façon à ce que la surface extérieure du mur fini se trouve entre les lignes « minimum » et « maximum ».

Español

- ⚠ **No suelde a menos de 4 pulg. de la pieza interior puesto que puede dañarla.**

Asegúrese de que la válvula quede nivelada.

Instale la válvula de modo que la superficie exterior de la pared terminada quede entre las marcas "min" y "max".

Flush the hot and cold supplies / Rincez les conduites d'alimentation de l'eau chaude et de l'eau froide / Lave los suministros frío y caliente

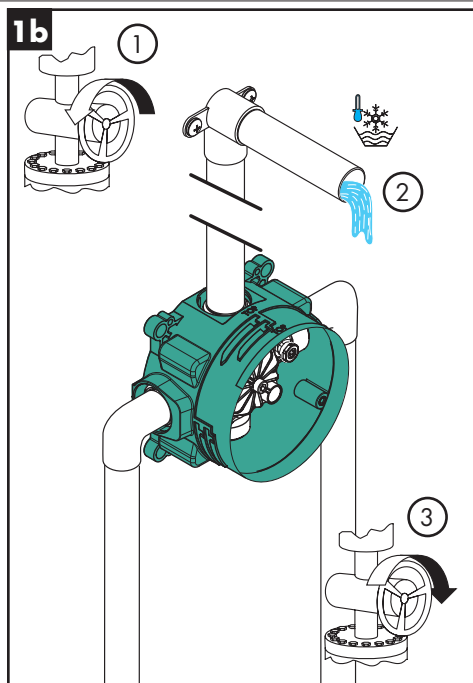
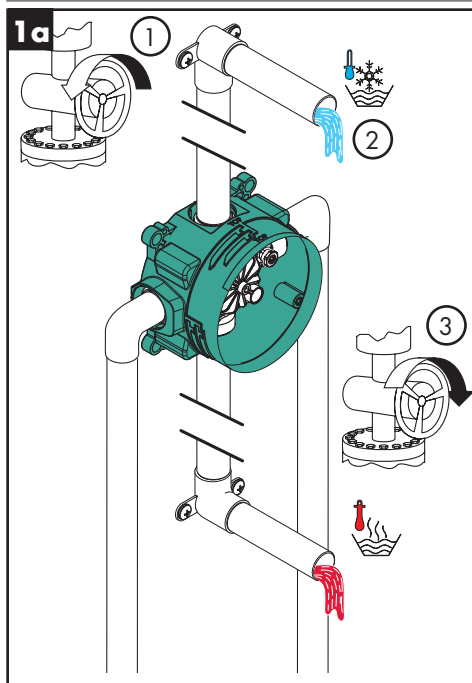

English

Français

Español

The hot supply will flush through the bottom outlet, and the cold supply will flush through the top outlet – see the arrows on the flushing block.

L'eau chaude s'écoulera par l'orifice de sortie du bas et l'eau froide par l'orifice de sortie du haut – reportez-vous aux flèches sur le bloc de rinçage.

El suministro de agua caliente se lava a través de la toma inferior y el de agua fría a través de la toma superior –vea las flechas del bloque de lavado.

If one outlet is plugged, flush one side.

Si un orifice est bouché, rincez l'autre côté.

Si una toma está taponada, lave un lado.

Turn the water off.

Coupez l'alimentation en eau.

Cierre el paso de agua.

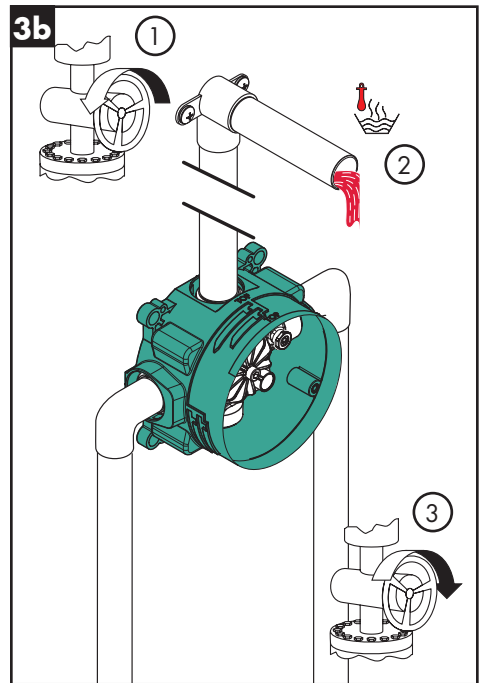
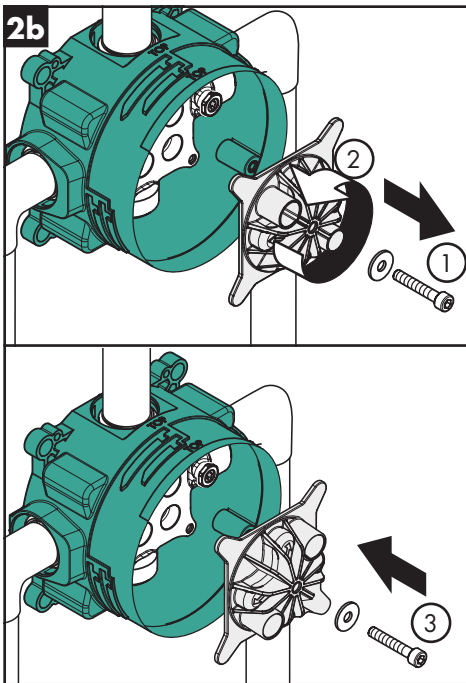

English

Français

Español

Remove the flushing block and turn it 90°.

Retirez le bloc de rinçage. Tournez-le à 90°.

Retire el bloque de lavado. Gírelo 90°.

Reinstall the flushing block.

Réinstallez-le.







Reinstálo.

Flush the other side.







Rincez l'autre côté.

Lave el otro lado.







Mixing Valve Trim Kits

Trim Type	Best for	Use with	Don't use with
Thermostatic mixing valve 	<ul style="list-style-type: none"> Single- or multiple-feature showers Use one or both outlets Provide volume control for each outlet 	<ul style="list-style-type: none"> Volume control valve 15974181 (1/2") or 15977181 (3/4") Trio diverter 15984181 Trio diverter with shutoff 15981181 Quattro diverter 15930181 or 15936181 FixFit wall outlet 	<ul style="list-style-type: none"> Diverter tub spout
Thermostat with shutoff 	<ul style="list-style-type: none"> Single feature shower Use only one outlet! 	<ul style="list-style-type: none"> Trio diverter 15984181 Quattro diverter 15930181 or 15936181 	<ul style="list-style-type: none"> Diverter tub spout Any valve with positive shutoff Volume control valve 15974181 (1/2") or 15977181 (3/4") FixFit wall outlet Trio diverter with shutoff 15981181
Thermostat with shutoff and diverter 	<ul style="list-style-type: none"> Two-feature shower Both outlets must be used. Do not plug either outlet. 	<ul style="list-style-type: none"> Trio Diverter 15984181 Quattro diverter 15930181 or 15936181 	<ul style="list-style-type: none"> Diverter tub spout Any valve with positive shutoff Volume control valve 15974181 (1/2") or 15977181 (3/4") FixFit wall outlet Trio diverter with shutoff 15981181
Pressure balance valve 	<ul style="list-style-type: none"> One-feature shower Tub/shower with diverter tub spout 	<ul style="list-style-type: none"> Trio Diverter 15984181 Quattro diverter 15930181 or 15936181 Diverter tub spout 	<ul style="list-style-type: none"> Any valve with positive shutoff Volume control valve 15974181 (1/2") or 15977181 (3/4") FixFit wall outlet Trio diverter with shutoff 15981181
Pressure balance with diverter 	<ul style="list-style-type: none"> Two-feature shower Both outlets must be used. Do not plug either outlet. 	<ul style="list-style-type: none"> Trio Diverter 15984181 Quattro diverter 15930181 or 15936181 	<ul style="list-style-type: none"> Diverter tub spout Any valve with positive shutoff Volume control valve 15974181 (1/2") or 15977181 (3/4") FixFit wall outlet Trio diverter with shutoff 15981181
ShowerSelect - 1 function 	<ul style="list-style-type: none"> Single feature shower Use only one outlet 	<ul style="list-style-type: none"> Trio Diverter 15984181 Quattro diverter 15930181 or 15936181 	<ul style="list-style-type: none"> Diverter tub spout Any valve with positive shutoff Volume control valve 15974181 (1/2") or 15977181 (3/4") FixFit wall outlet Trio diverter with shutoff 15981181
ShowerSelect - 2 function 	<ul style="list-style-type: none"> Two-feature shower Both outlets must be used Do not plug either outlet 	<ul style="list-style-type: none"> Trio Diverter 15984181 Quattro diverter 15930181 or 15936181 	<ul style="list-style-type: none"> Diverter tub spout Any valve with positive shutoff Volume control valve 15974181 (1/2") or 15977181 (3/4") FixFit wall outlet Trio diverter with shutoff 15981181











Jeu de Garniture

	Usage	Utiliser avec	Ne pas utiliser avec
Mitigeur thermostatique 	<ul style="list-style-type: none"> Installation à une fonction Installation de multiple-fonctions <p>! Fournit un robinet d'arrêt pour chaque orifice de sortie.</p>	<ul style="list-style-type: none"> Robinet d'arrêt 15974181 (1/2") ou 15977181 (3/4") Trio inverseur 15984181 Trio inverseur avec robinet d'arrêt 15981181 Quattro inverseur 15930181 or 15936181 FixFit wall outlet 	<p>! Bec de baignoire inverseur</p>
Mitigeur thermostatique avec robinet d'arrêt 	<ul style="list-style-type: none"> Installation à une fonction N'installez qu'à une seule conduite de sortie. 	<ul style="list-style-type: none"> Trio inverseur 15984181 Quattro inverseur 15930181 or 15936181 	<p>! Bec de baignoire inverseur</p> <ul style="list-style-type: none"> Dispositif d'arrêt Robinet d'arrêt 15974181 (1/2") or 15977181 (3/4") FixFit wall outlet Trio inverseur avec robinet d'arrêt 15981181
Mitigeur thermostatique avec robinet d'arrêt et inverseur 	<ul style="list-style-type: none"> Installation à deux fonctions N'utilisez pas cette option pour une douche à une fonction. 	<ul style="list-style-type: none"> Trio inverseur 15984181 Quattro inverseur 15930181 or 15936181 	<p>! Bec de baignoire inverseur</p> <ul style="list-style-type: none"> Dispositif d'arrêt Robinet d'arrêt 15974181 (1/2") or 15977181 (3/4") FixFit wall outlet Trio inverseur avec robinet d'arrêt 15981181
Mitigeur équilibrage de pression 	<ul style="list-style-type: none"> Installation à une fonction Douche/baignoire avec Bec de baignoire inverseur 	<ul style="list-style-type: none"> Trio inverseur 15984181 Quattro inverseur 15930181 or 15936181 Bec de baignoire inverseur 	<p>! Dispositif d'arrêt</p> <ul style="list-style-type: none"> Robinet d'arrêt 15974181 (1/2") or 15977181 (3/4") FixFit wall outlet Trio inverseur avec robinet d'arrêt 15981181
Mitigeur équilibrage de pression avec inverseur 	<ul style="list-style-type: none"> Installation à deux fonctions N'utilisez pas cette option pour une douche à une fonction. 	<ul style="list-style-type: none"> Trio inverseur 15984181 Quattro inverseur 15930181 or 15936181 	<p>! Bec de baignoire inverseur</p> <ul style="list-style-type: none"> Dispositif d'arrêt Robinet d'arrêt 15974181 (1/2") or 15977181 (3/4") FixFit wall outlet Trio inverseur avec robinet d'arrêt 15981181
ShowerSelect 1-fonction 	<ul style="list-style-type: none"> Installation à une fonction N'installez qu'à une seule conduite de sortie. 	<ul style="list-style-type: none"> Trio inverseur 15984181 Quattro inverseur 15930181 or 15936181 	<p>! Bec de baignoire inverseur</p> <ul style="list-style-type: none"> Dispositif d'arrêt Robinet d'arrêt 15974181 (1/2") or 15977181 (3/4") FixFit wall outlet Trio inverseur avec robinet d'arrêt 15981181
ShowerSelect 2 fonctions 	<ul style="list-style-type: none"> Installation à deux fonctions N'utilisez pas cette option pour une douche à une fonction. 	<ul style="list-style-type: none"> Trio inverseur 15984181 Quattro inverseur 15930181 or 15936181 	<p>! Bec de baignoire inverseur</p> <ul style="list-style-type: none"> Dispositif d'arrêt Robinet d'arrêt 15974181 (1/2") or 15977181 (3/4") FixFit wall outlet Trio inverseur avec robinet d'arrêt 15981181





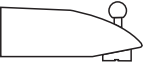
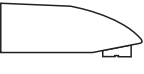

Juegos de piezas exteriores

	Uso	Utilice con	No utilice con
Termostato 	<ul style="list-style-type: none"> • Instalación de una sola función • Instalación de varias funciones • Proporcione llave de paso para cada toma . 	<ul style="list-style-type: none"> • Llave de paso 15974181 (1/2") ou 15977181 (3/4") • Trio distribuidor 15984181 • Trio distribuidor con llave de paso 15981181 • Quattro distribuidor 15930181 o 15936181 • FixFit wall outlet 	<ul style="list-style-type: none"> ! Surtidor de bañera tipo distribuidor
Termostato con llave de paso 	<ul style="list-style-type: none"> • Instalación de una sola función • Conecte desde una toma solamente 	<ul style="list-style-type: none"> • Trio distribuidor 15984181 • Quattro distribuidor 15930181 o 15936181 	<ul style="list-style-type: none"> ! Surtidor de bañera tipo distribuidor • Llave de paso 15974181 (1/2") o 15977181 (3/4") • FixFit wall outlet • Trio distribuidor con llave de paso 15981181
Termostato con llave de paso y distribuidor 	<ul style="list-style-type: none"> • Instalación de dos funciones • No use para duchas de una sola función. 	<ul style="list-style-type: none"> • Trio distribuidor 15984181 • Quattro distribuidor 15930181 o 15936181 	<ul style="list-style-type: none"> ! Surtidor de bañera tipo distribuidor • Dispositif d'arrêt • Llave de paso 15974181 (1/2") o 15977181 (3/4") • FixFit wall outlet • Trio distribuidor con llave de paso 15981181
Válvula de presión balanceada 	<ul style="list-style-type: none"> • Instalación de una sola función • Bañera/ducha con un surtidor de bañera tipo distribuidor 	<ul style="list-style-type: none"> • Trio distribuidor 15984181 • Quattro distribuidor 15930181 o 15936181 • Surtidor de bañera tipo distribuidor 	<ul style="list-style-type: none"> • Llave de paso 15974181 (1/2") o 15977181 (3/4") • FixFit wall outlet • Trio distribuidor con llave de paso 15981181
Válvula de presión balanceada con distribuidor 	<ul style="list-style-type: none"> • Instalación de dos funciones • No use para duchas de una sola función. 	<ul style="list-style-type: none"> • Trio distribuidor 15984181 • Quattro distribuidor 15930181 o 15936181 	<ul style="list-style-type: none"> ! Surtidor de bañera tipo distribuidor • Llave de paso 15974181 (1/2") o 15977181 (3/4") • FixFit wall outlet • Trio distribuidor con llave de paso 15981181
ShowerSelect 1-función 	<ul style="list-style-type: none"> • Instalación de una sola función • Conecte desde una toma solamente 	<ul style="list-style-type: none"> • Trio distribuidor 15984181 • Quattro distribuidor 15930181 o 15936181 	<ul style="list-style-type: none"> ! Surtidor de bañera tipo distribuidor • Llave de paso 15974181 (1/2") o 15977181 (3/4") • FixFit wall outlet • Trio distribuidor con llave de paso 15981181
ShowerSelect 2-funciones 	<ul style="list-style-type: none"> • Instalación de dos funciones • No use para duchas de una sola función. 	<ul style="list-style-type: none"> • Trio distribuidor 15984181 • Quattro distribuidor 15930181 o 15936181 	<ul style="list-style-type: none"> ! Surtidor de bañera tipo distribuidor • Llave de paso 15974181 (1/2") o 15977181 (3/4") • FixFit wall outlet • Trio distribuidor con llave de paso 15981181

Symbols used:

	hot water	eau chaude	agua caliente
	cold water	eau froide	agua fría
	reinforce wall at this location	le mur n'a pas besoin d'être renforcé à cet endroit	en este sector es necesario un refuerzo del muro
	thermostatic mixer	mitigeur thermostatique	termostato
	thermostat w/shutoff	mitigeur thermostatique avec robinet d'arrêt	termostato con llave de paso
	ShowerSelect 1	ShowerSelect 1	ShowerSelect 1
	thermostat w/shutoff & diverter	mitigeur thermostatique avec robinet d'arrêt et inverseur	termostato con llave de paso y distribuidor
	ShowerSelect 2	ShowerSelect 2	ShowerSelect 2
	pressure balance valve	mitigeur équilibrage de pression	válvula de presión balanceada
	pressure balance valve w/diverter	mitigeur équilibrage de pression avec inverseur	válvula de presión balanceada con distribuidor
	diverter tub spout	Bec de baignoire inverseur	surtidor de bañera tipo distribuidor
	tub spout	bec de baignoire	surtidor de bañera

Symbols used:

	<p>plug the unused outlet</p>	<p>la sortie non utilisée doit être condamnée avec un bouchon laiton</p>	<p>la salida que no se utiliza debe ser tapada</p>
	<p>Quattro diverter 15930181 or 15936181</p>	<p>Quattro inverseur 15930181 ou 15936181</p>	<p>Quattro distribuidor 15930181 o 15936181</p>
	<p>Trio diverter w/shutoff 15981181</p>	<p>Trio inverseur avec robinet d'arrêt 15981181</p>	<p>Trio distribuidor con llave de paso 15981181</p>
	<p>Trio diverter 15984181</p>	<p>Trio inverseur 15984181</p>	<p>Trio distribuidor 15984181</p>
	<p>volume control valve 15974181 (1/2") or 15977181 (3/4")</p>	<p>robinet d'arrêt 15974181 (1/2") ou 15977181 (3/4")</p>	<p>llave de paso 15974181 (1/2") ou 15977181 (3/4")</p>
	<p>do not use!</p>	<p>n'utilisez pas!</p>	<p>¡no use!</p>
	<p>do not use a diverter tub spout!</p>	<p>n'utilisez pas une Bec de baignoire inverseur!</p>	<p>¡no use un surtidor de bañera tipo distribuidor!</p>

Suggested Installations / Suggestions d'installation / Sugerencias de instalación

English	French	Spanish	Page / Page / Pagina
Thermostatic mixer	Mitigeur thermostatique	Termostato	24 - 32
Thermostat w/shutoff	Mitigeur thermostatique avec robinet d'arrêt	Termostato con llave de paso	33 - 36
ShowerSelect 1			33 - 36
Thermostat w/shutoff & diverter	Mitigeur thermostatique avec robinet d'arrêt et inverseur	Termostato con llave de paso y distribuidor	37 - 39
ShowerSelect 2			37 - 39
Pressure balance valve	Mitigeur équilibrage de pression	Válvula de presión balanceada	33 - 36, 40
Pressure balance w/diverter	Mitigeur équilibrage de pression avec inverseur	Válvula de presión balanceada con distribuidor	41 - 43
Tub Spout / Porter	Combiné bec déverseur / support de douche	Caño de bañera con porter y teleducha	
Axor Urquiola 11435xx1			29
Showerhead	Pomme de douche	Ducha Cabezal	
Raindance 28411xx1			30
Raindance 27373xx1			31
Raindance 28417xx1, 28403xx1			32
Raindance 28433xx1			35

Suggested Installations / Suggestions d'installation / Sugerencias de instalación

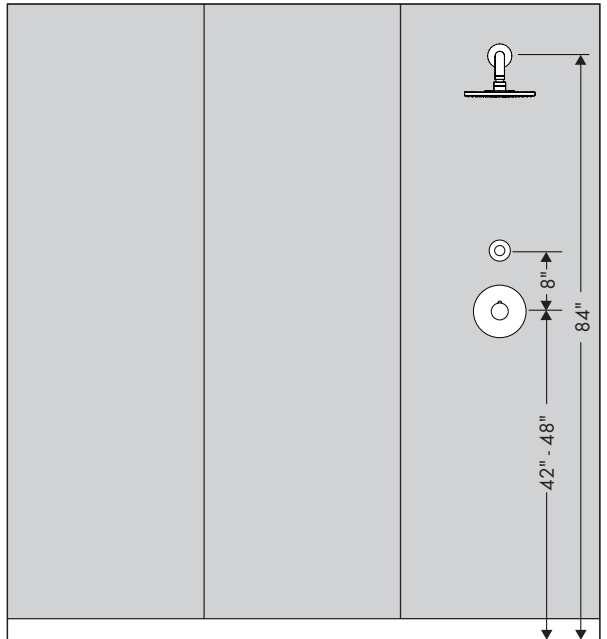
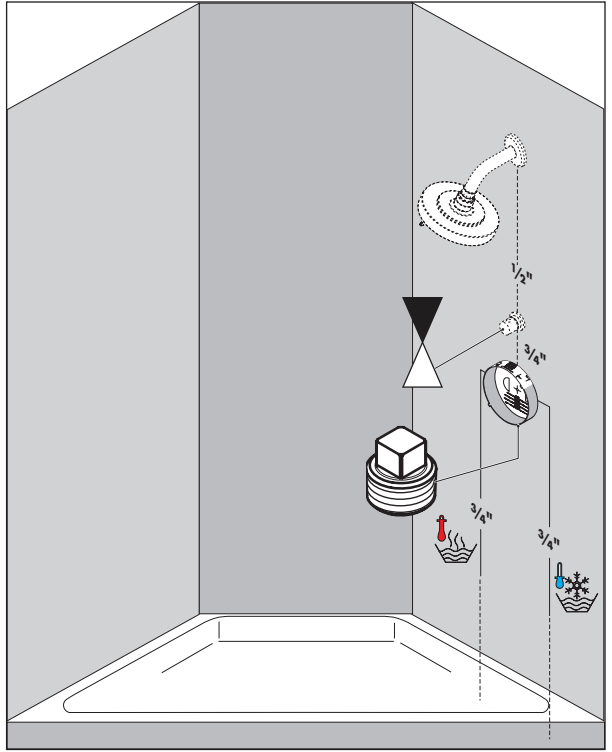
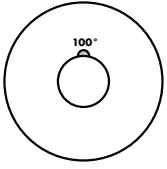

Suggested Installations / Suggestions d'installation / Sugerencias de instalación

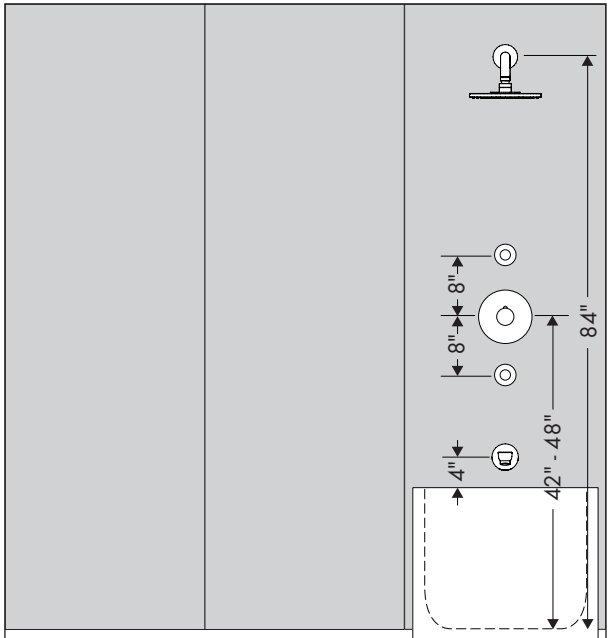
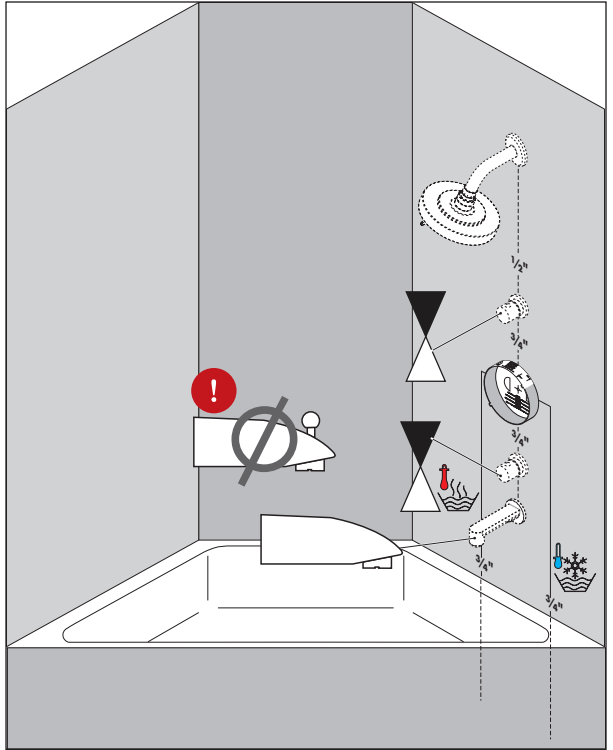
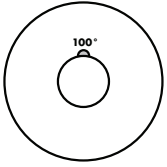

Suggested Installations / Suggestions d'installation / Sugerencias de instalación

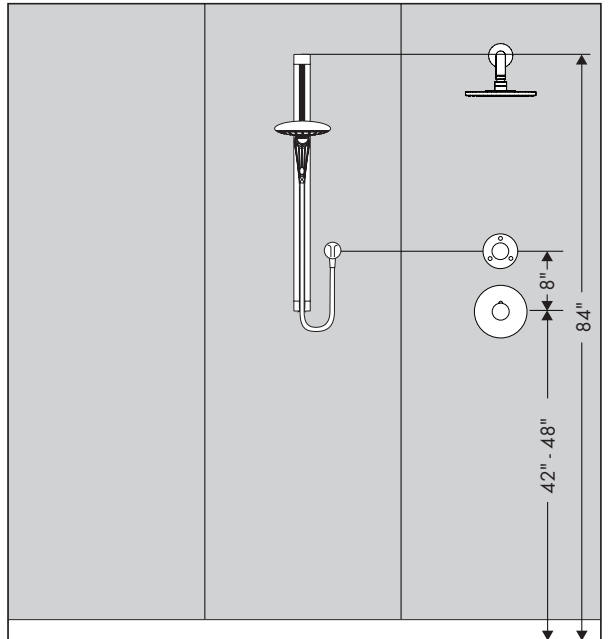
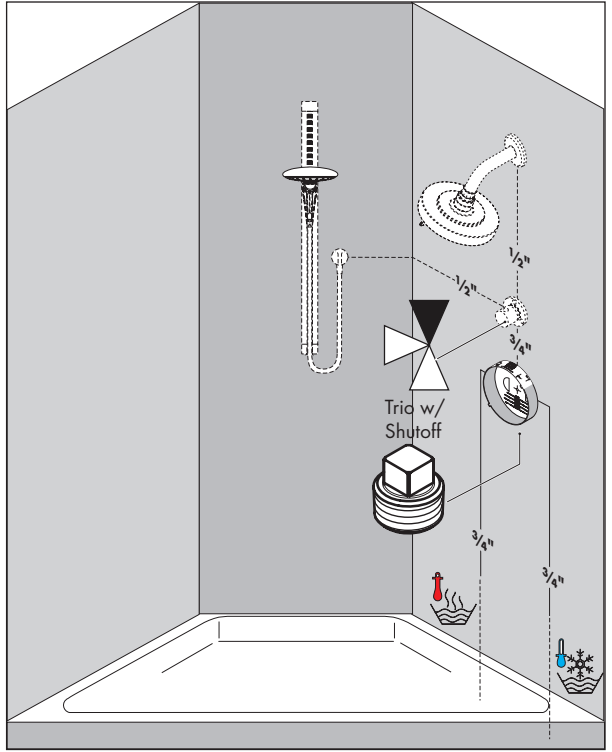
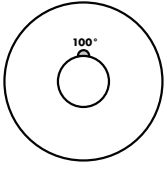

Suggested Installations / Suggestions d'installation / Sugerencias de instalación

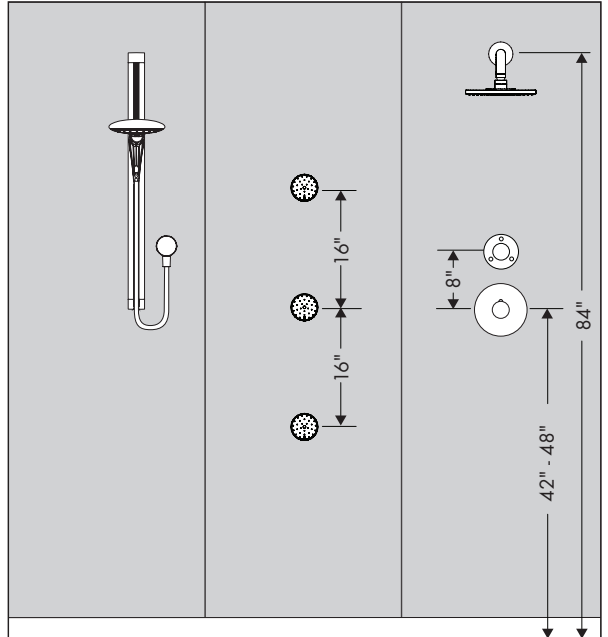
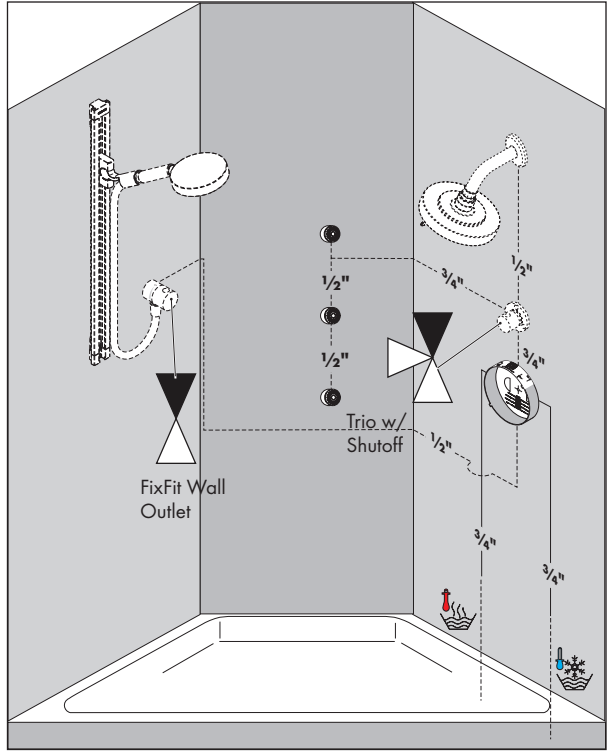
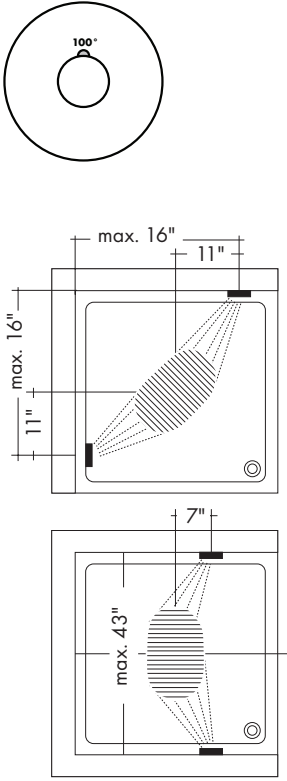

Suggested Installations / Suggestions d'installation / Sugerencias de instalación

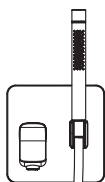
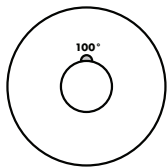

Axor Urquiola
11435xx1

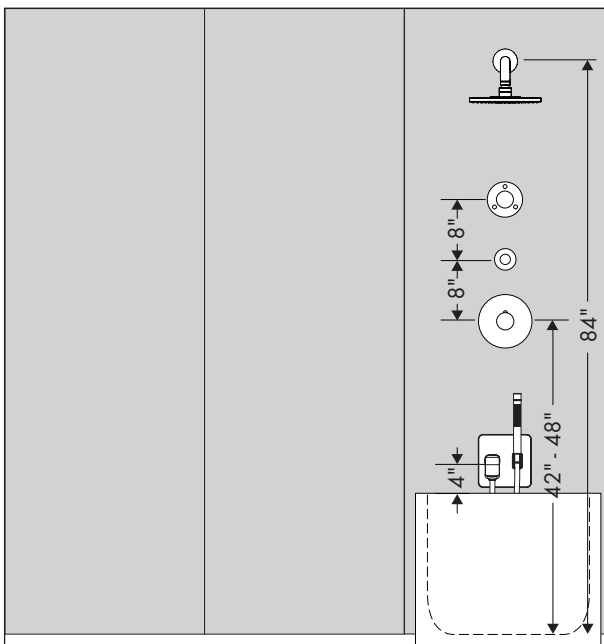
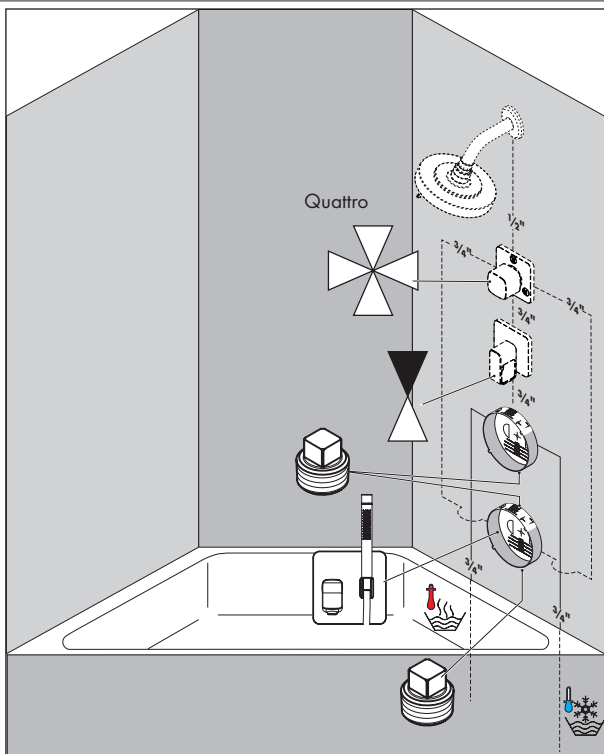

Suggested Installations / Suggestions d'installation / Sugerencias de instalación

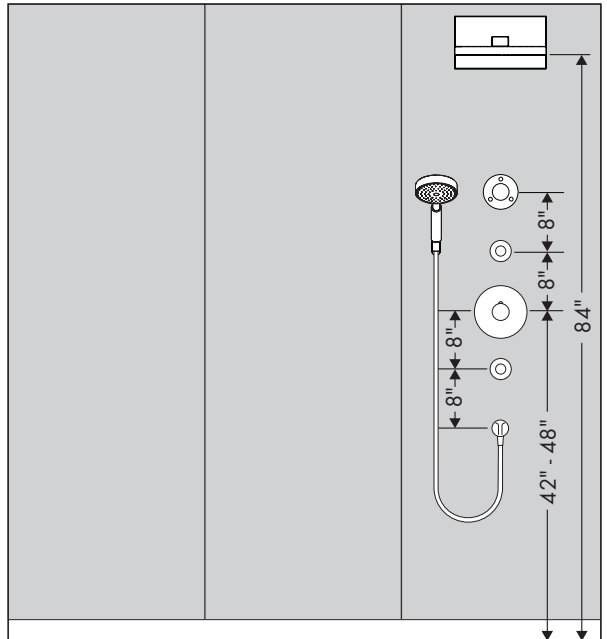
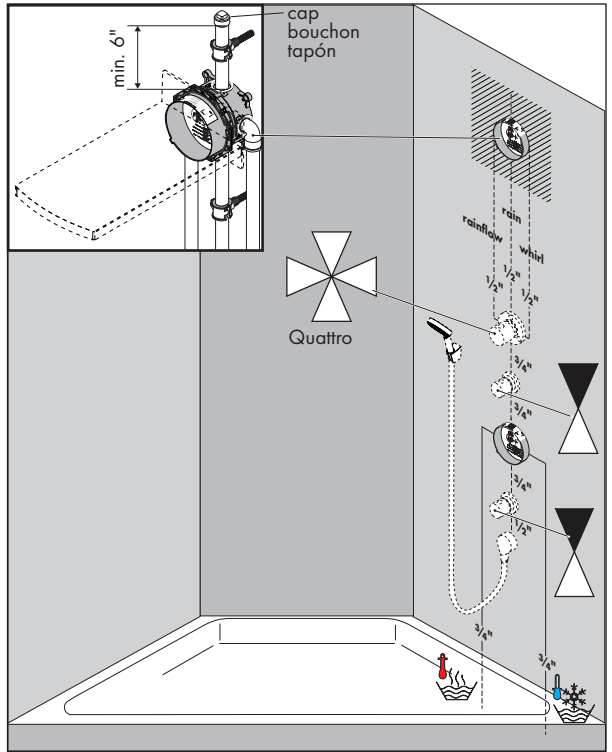
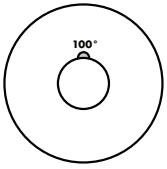

Suggested Installations / Suggestions d'installation / Sugerencias de instalación

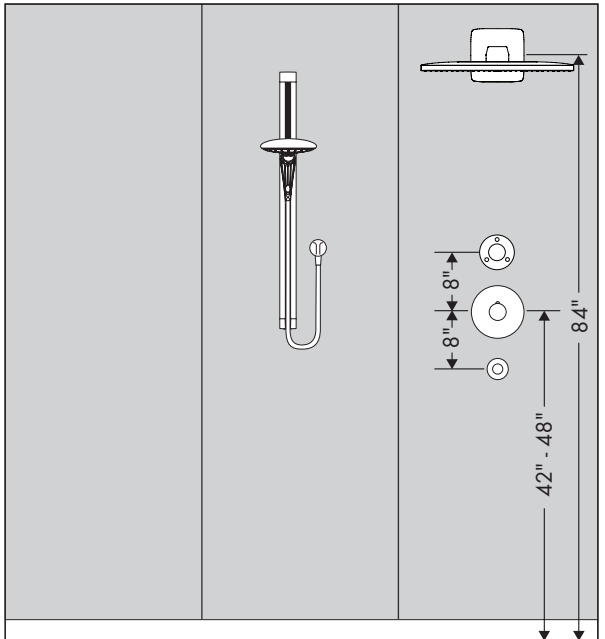
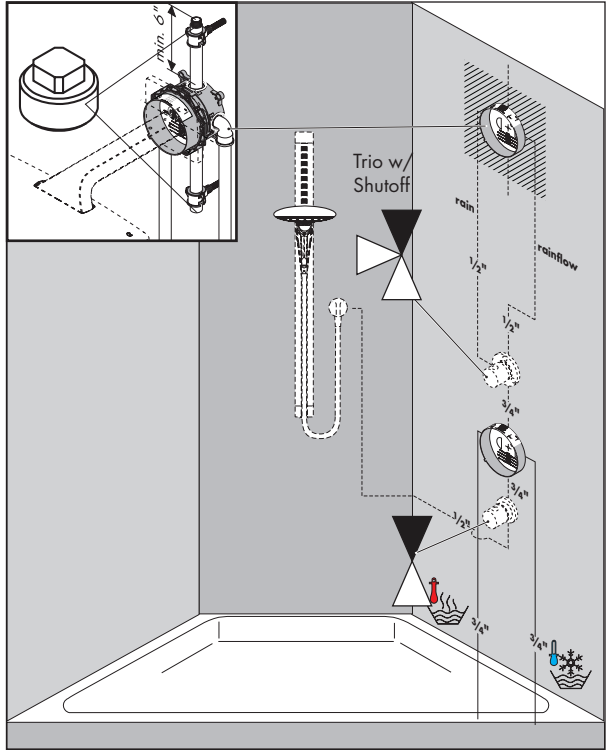
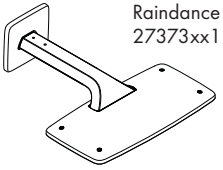
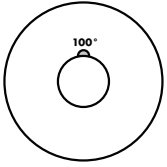

Suggested Installations / Suggestions d'installation / Sugerencias de instalación

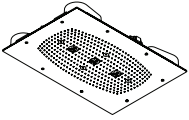
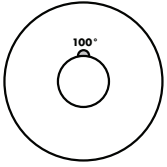

Raindance Imperial 600 AIR
28417001

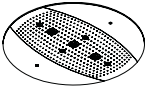

Raindance Imperial 600 AIR
28403001

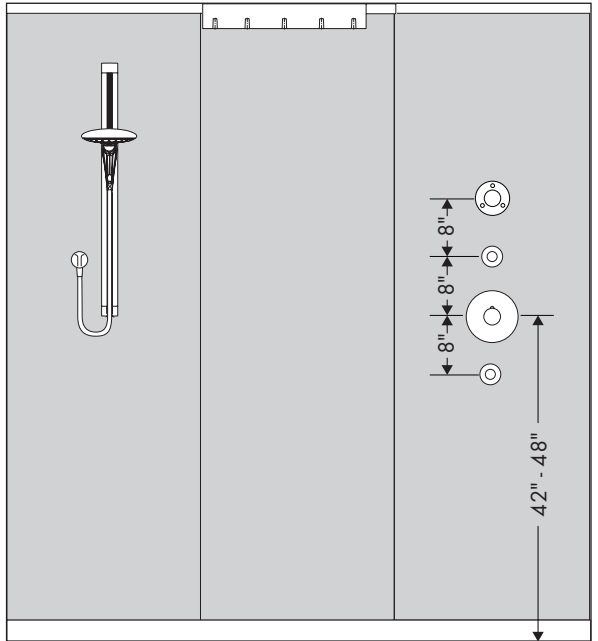
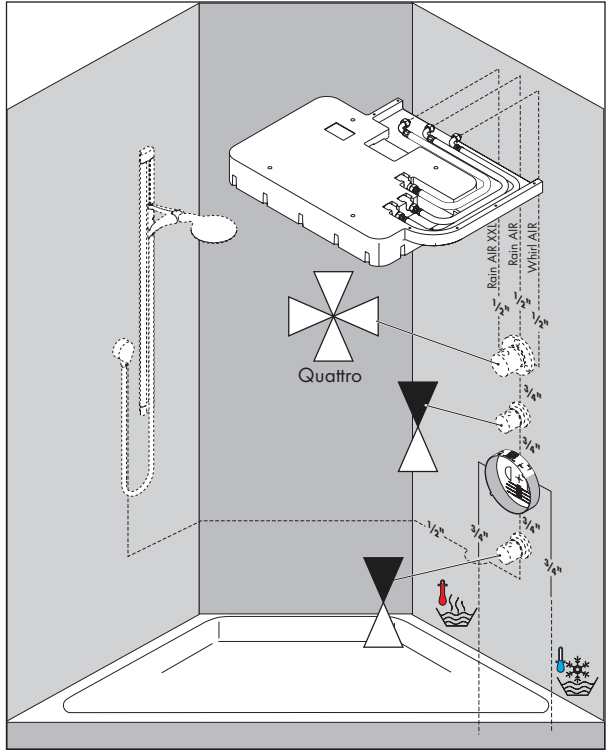

Suggested Installations / Suggestions d'installation / Sugerencias de instalación

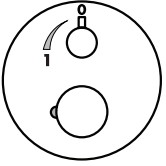

or / o / ou

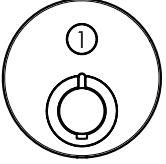

or / o / ou

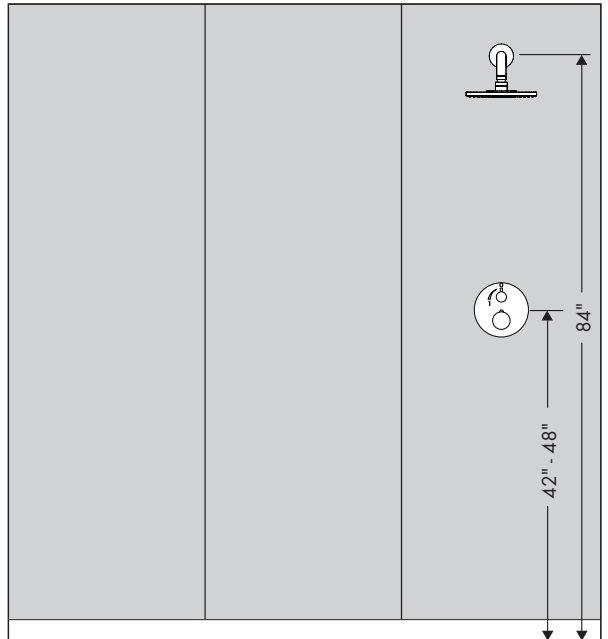
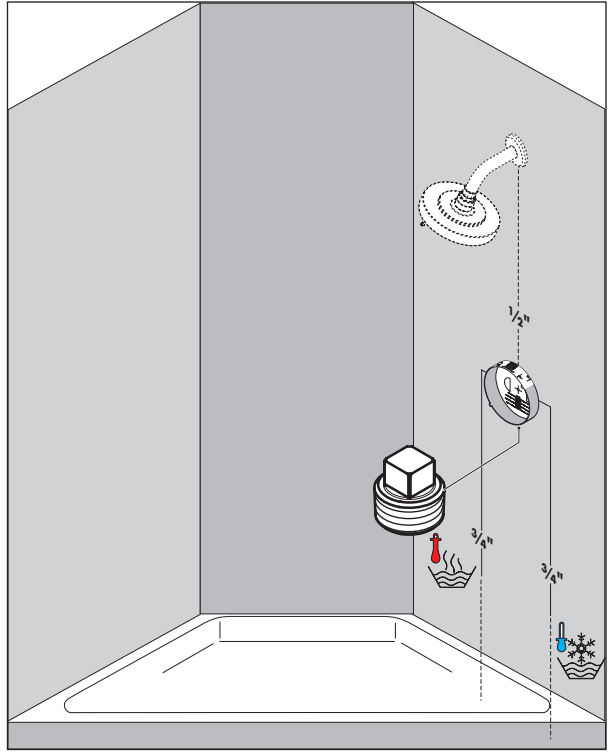
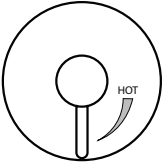

Suggested Installations / Suggestions d'installation / Sugerencias de instalación

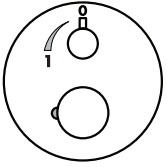

or / o / ou

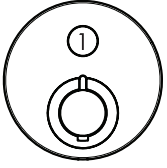

or / o / ou

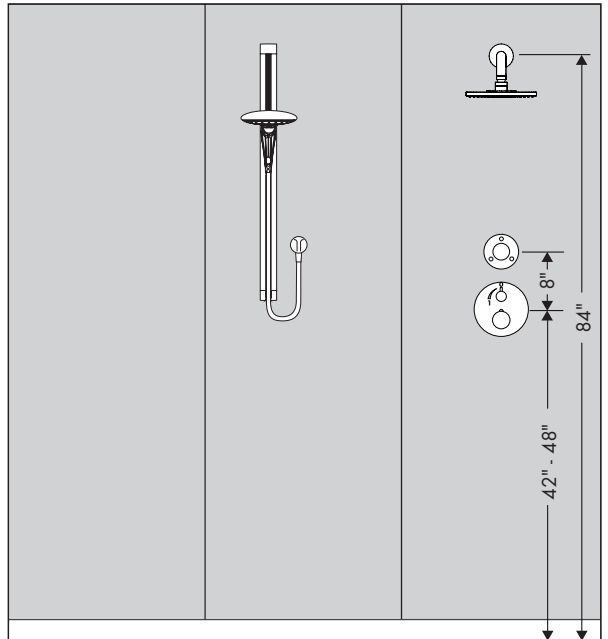
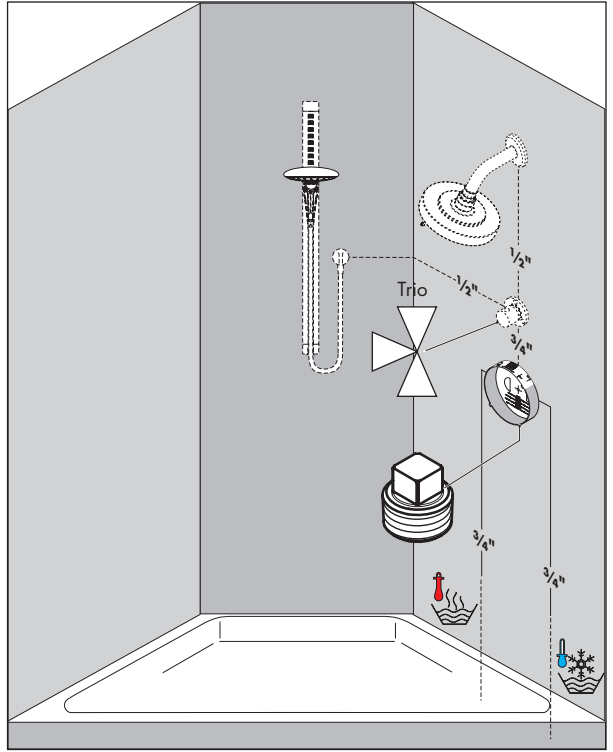
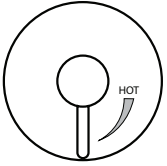

Suggested Installations / Suggestions d'installation / Sugerencias de instalación

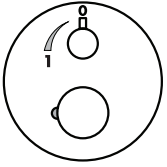

or / o / ou

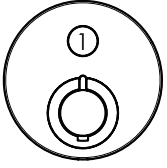

or / o / ou

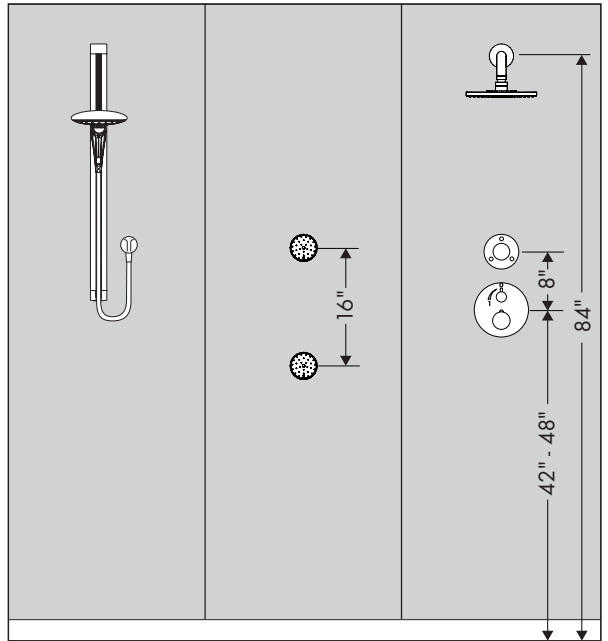
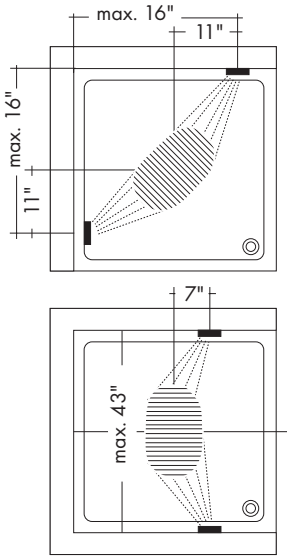
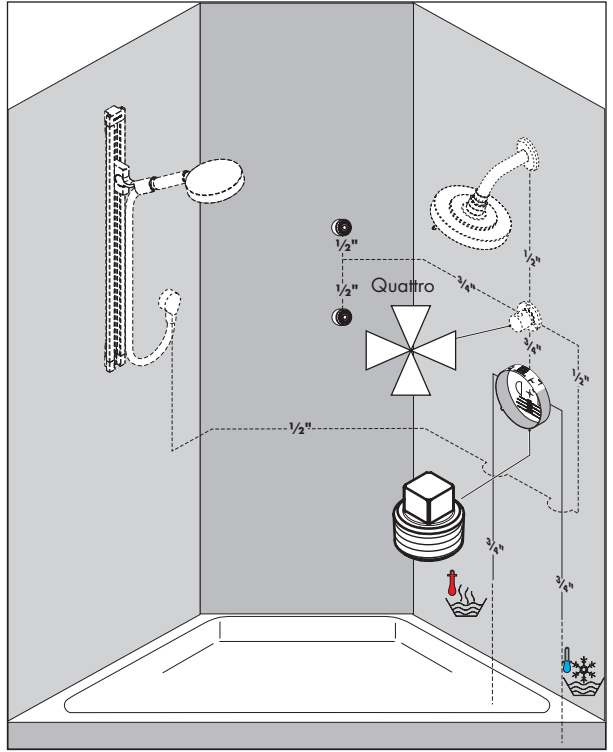
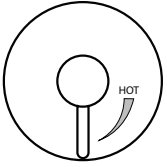

Suggested Installations / Suggestions d'installation / Sugerencias de instalación

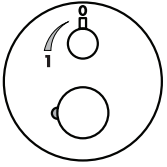

or / o / ou

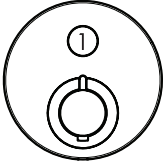

or / o / ou

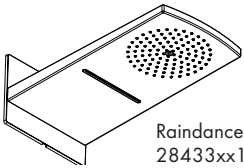
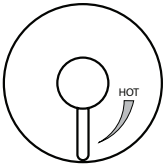

Raindance
28433xx1

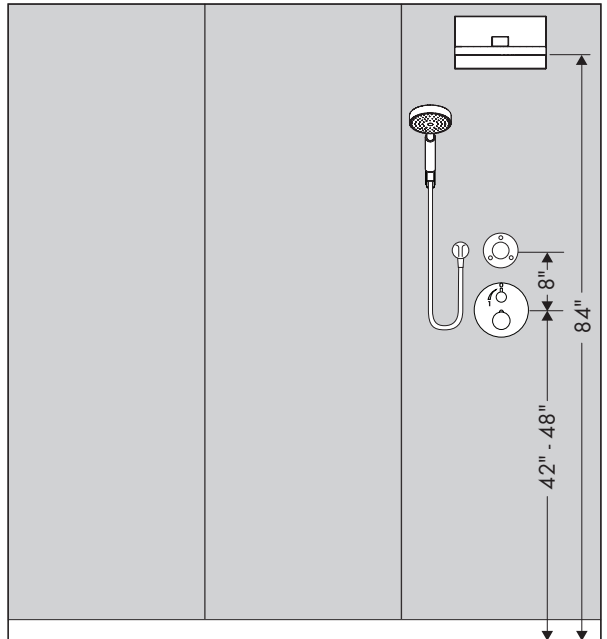
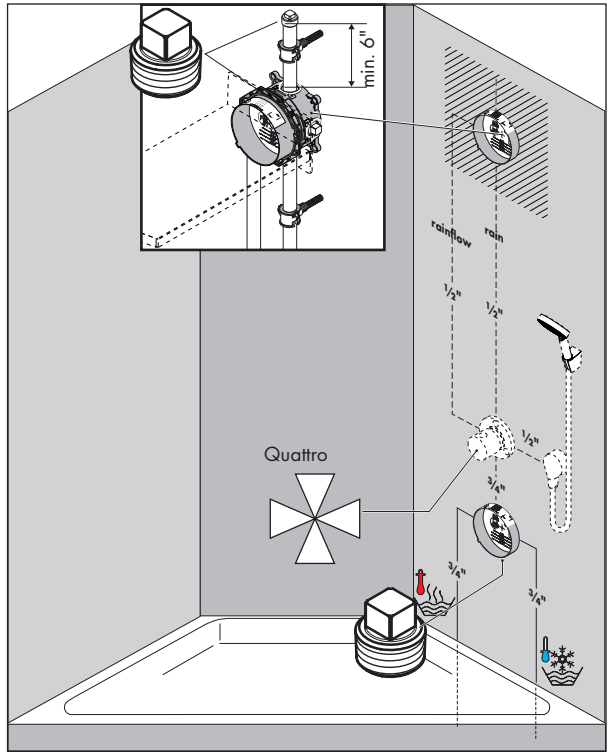

Suggested Installations / Suggestions d'installation / Sugerencias de instalación

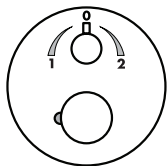

or / o / ou

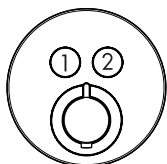

Outlet #1 is the bottom outlet.

Outlet #2 is the top outlet.

Sortie № 1 est la sortie inférieure.

Sortie № 2 est la sortie supérieure.

Salida № 1 es la salida inferior.

Salida № 2 es la salida superior.

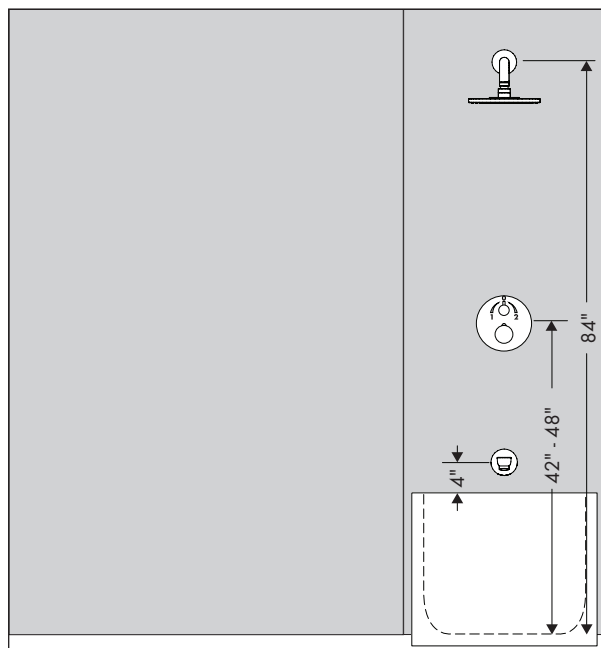
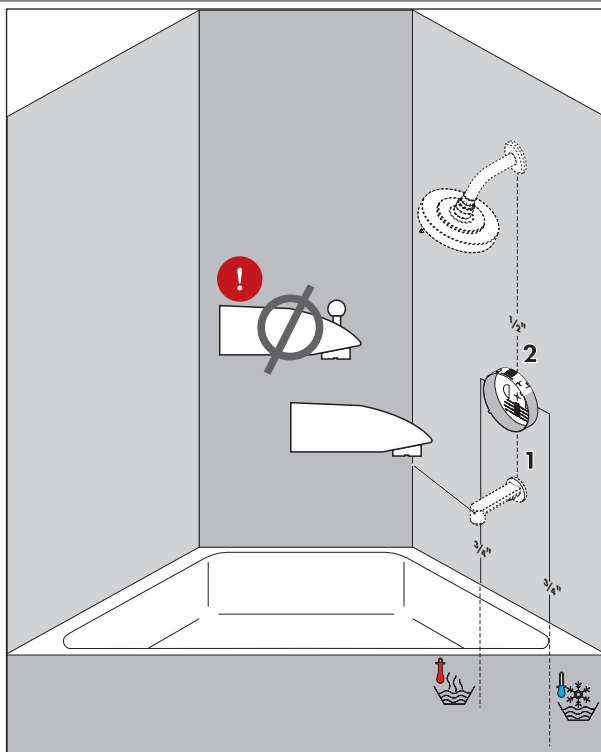

Suggested Installations / Suggestions d'installation / Sugerencias de instalación

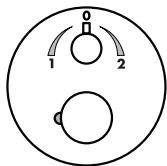

or / o / ou

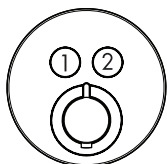

Outlet #1 is the bottom outlet.

Outlet #2 is the top outlet.

Sortie № 1 est la sortie inférieure.

Sortie № 2 est la sortie supérieure.

Salida № 1 es la salida inferior.

Salida № 2 es la salida superior.

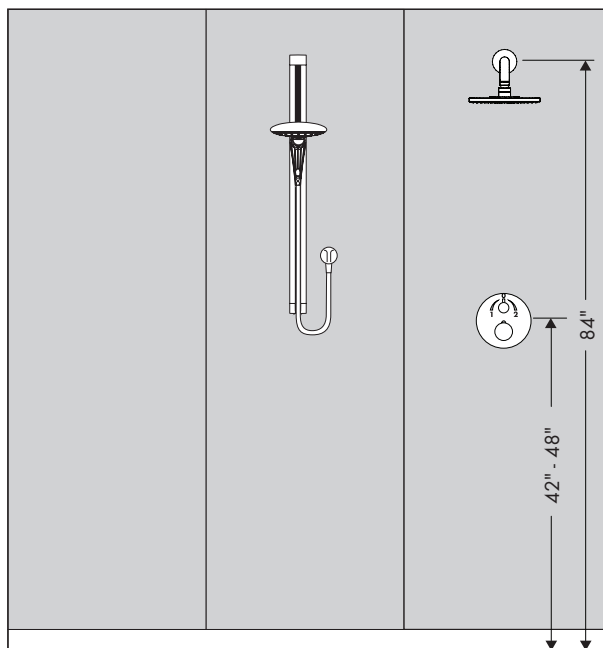
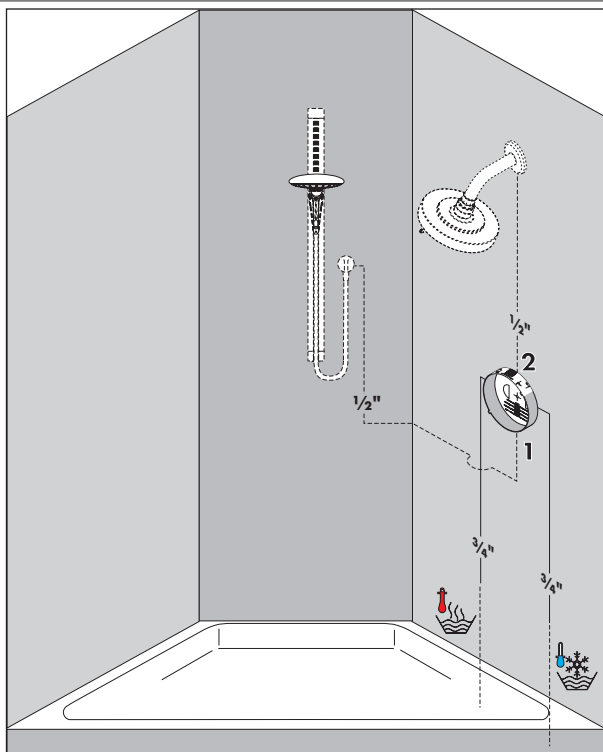

Suggested Installations / Suggestions d'installation / Sugerencias de instalación

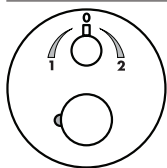

or / o / ou

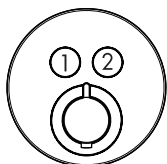

Outlet #1 is the bottom outlet.

Outlet #2 is the top outlet.

Sortie № 1 est la sortie inférieure.

Sortie № 2 est la sortie supérieure.

Salida № 1 es la salida inferior.

Salida № 2 es la salida superior.

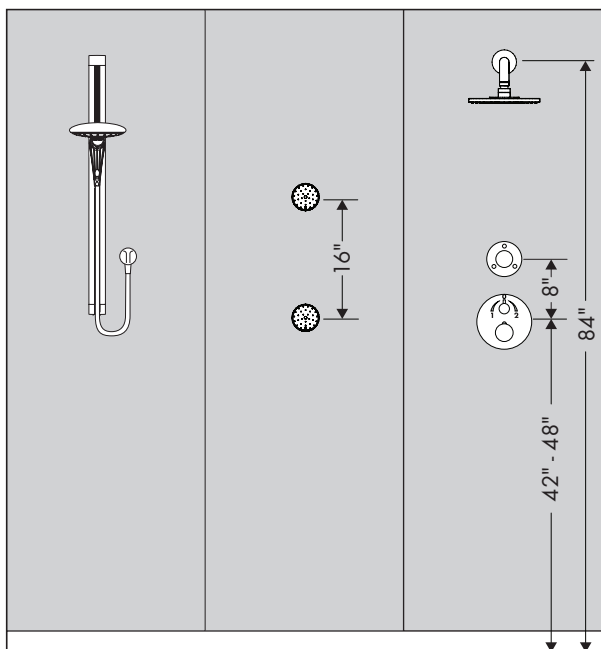
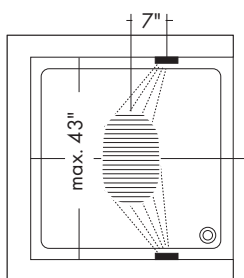
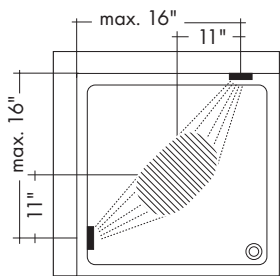
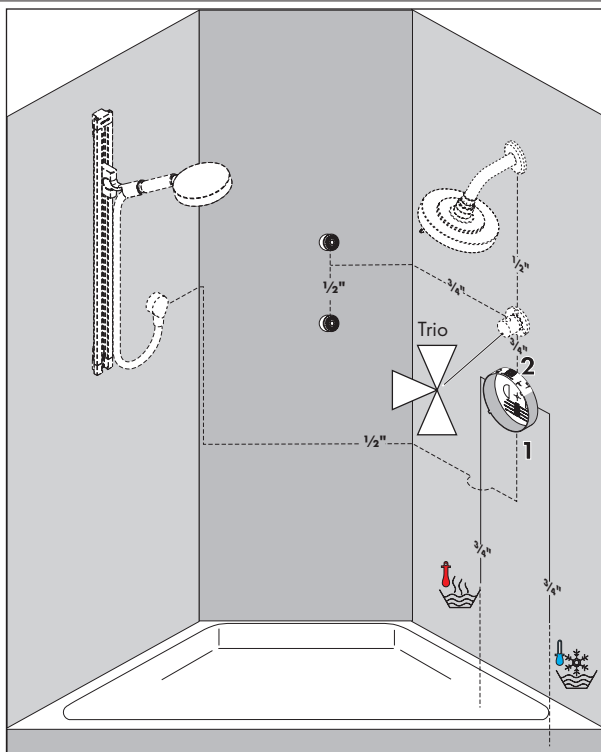

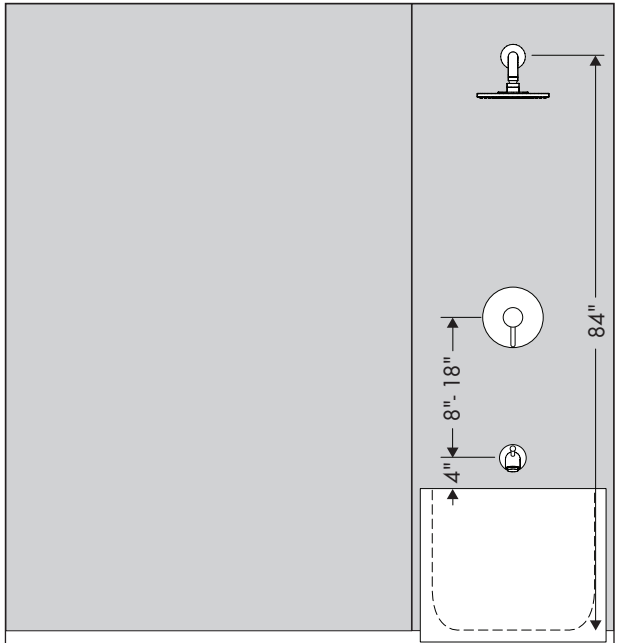
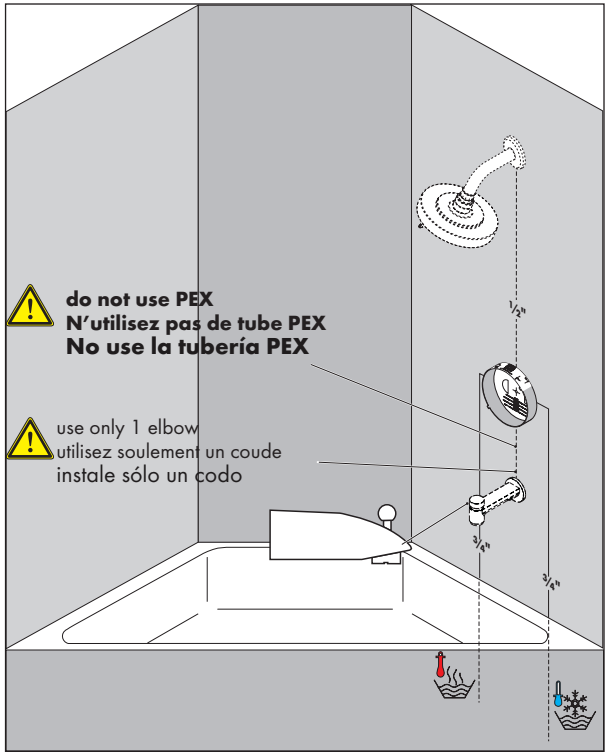
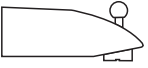
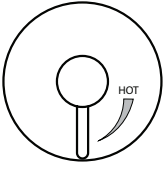

Suggested Installations / Suggestions d'installation / Sugerencias de instalación

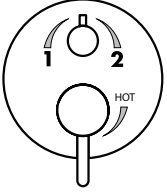

Outlet #1 is the top outlet.
Outlet #2 is the bottom outlet.
Sortie № 1 est la sortie supérieure.
Sortie № 2 est la sortie inférieure.
Salida № 1 es la salida superior.
Salida № 2 es la salida inferior.

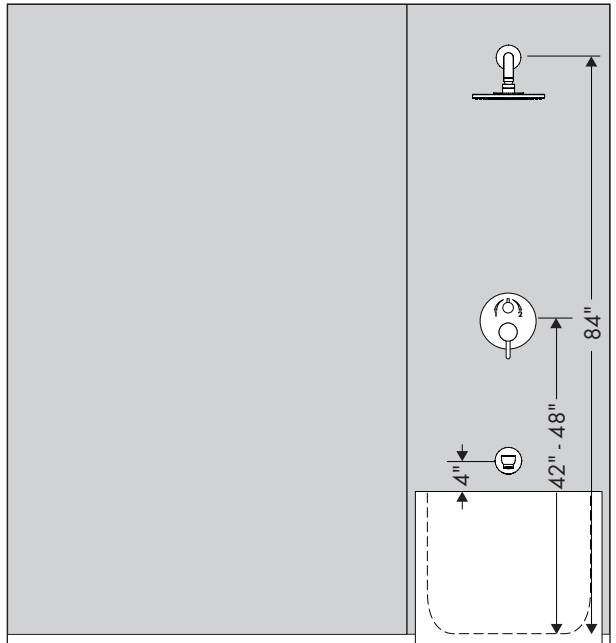
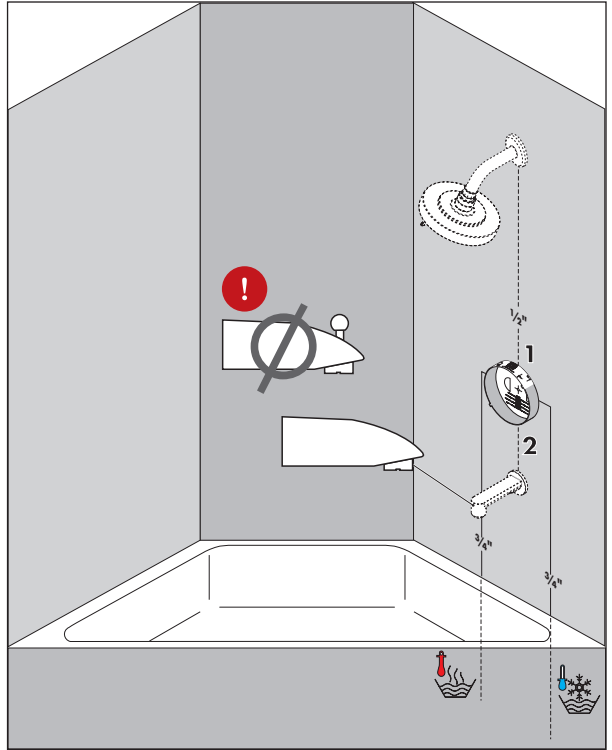

Suggested Installations / Suggestions d'installation / Sugerencias de instalación

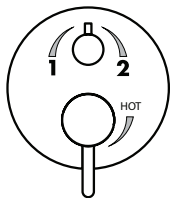

Outlet #1 is the top outlet.

Outlet #2 is the bottom outlet.

Sortie № 1 est la sortie supérieure.

Sortie № 2 est la sortie inférieure.

Salida № 1 es la salida superior.

Salida № 2 es la salida inferior.

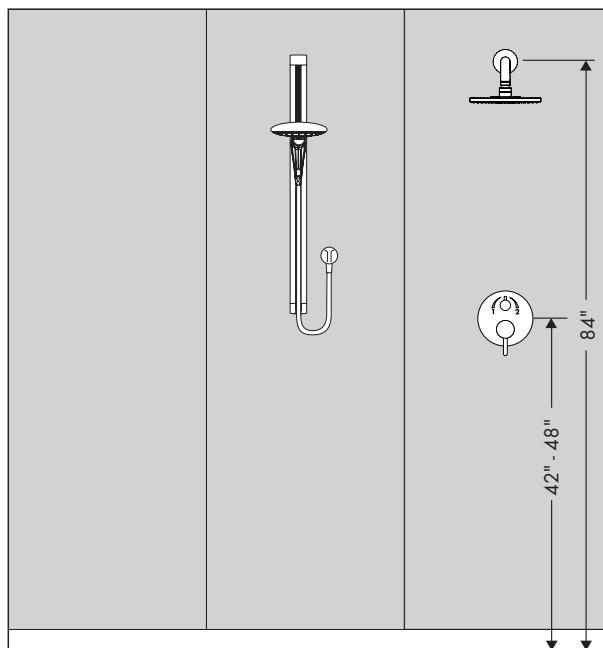
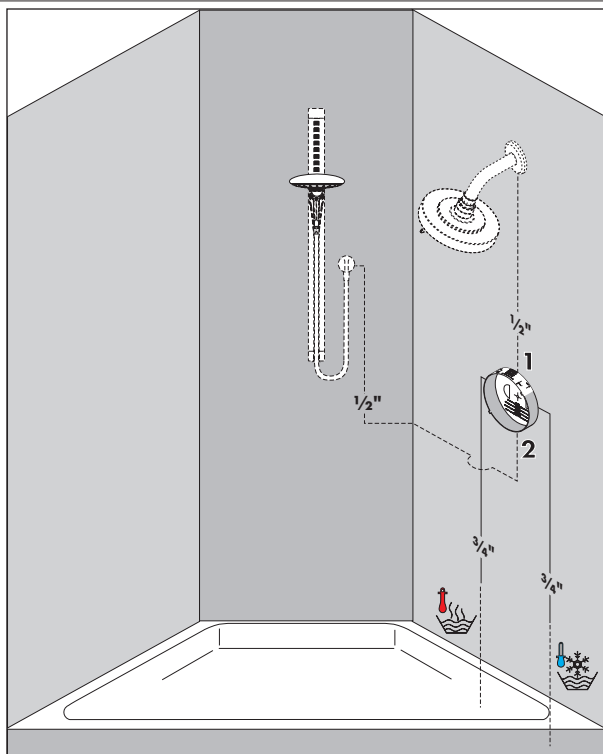

Suggested Installations / Suggestions d'installation / Sugerencias de instalación

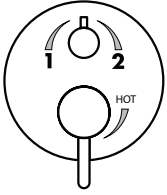

Outlet #1 is the top outlet.
 Outlet #2 is the bottom outlet.
 Sortie № 1 est la sortie supérieure.
 Sortie № 2 est la sortie inférieure.
 Salida № 1 es la salida superior.
 Salida № 2 es la salida inferior.

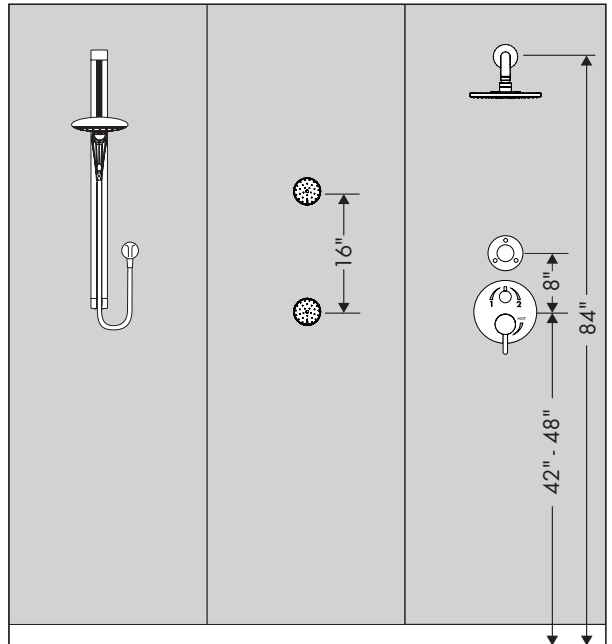
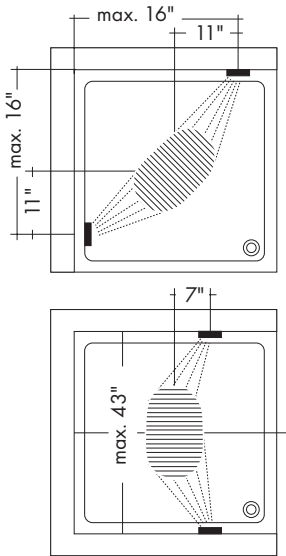
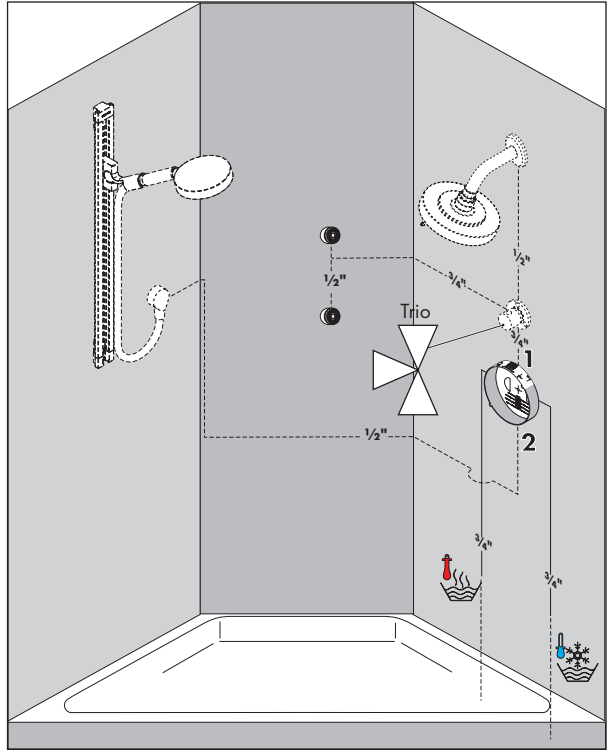

Limited Consumer Warranty

This warranty is limited to products manufactured by Hansgrohe, Inc. ("Hansgrohe") that are purchased by a consumer in the United States or Canada after March 1, 1996, and installed in either the United States or in Canada.

WHO IS COVERED BY THE WARRANTY

This limited warranty extends to the original purchaser only. This warranty is non-transferable. Hansgrohe neither assumes nor authorizes any person to create for it any other obligation or liability in connection with this product.

LENGTH OF WARRANTY

If you are a consumer who purchased the product for use primarily for personal, family or household purposes, this limited warranty starts on the date of purchase and extends for as long as you own the product and the home in which the product is originally installed. If you purchased the product for use primarily for any other purpose, including, without limitation, a commercial purpose, this limited warranty starts on the date of purchase and extends (i) for 1 year, with respect to Hansgrohe and Commercial products, and (ii) for 5 years, with respect to Axor products. The Rubbed Bronze finish is subject to a 3-year limited warranty starting on the date of purchase.

WHAT IS COVERED BY THE WARRANTY

This limited warranty covers only your Hansgrohe manufactured product. Hansgrohe warrants this product against defects in material or workmanship as follows:

Hansgrohe will replace at no charge for parts only or, at its option, replace any product or part of the product that proves defective because of improper workmanship and/or material, under normal installation, use, service and maintenance. If Hansgrohe is unable to provide a replacement and repair is not practical or cannot be made in timely fashion, Hansgrohe may elect to refund the purchase price in exchange for the return of the product. REPAIR OR REPLACEMENT (OR, IN LIMITED CIRCUMSTANCES, REFUND OF THE PURCHASE PRICE) AS PROVIDED UNDER THIS LIMITED WARRANTY IS THE EXCLUSIVE REMEDY OF THE PURCHASER.

WHAT IS NOT COVERED BY THE WARRANTY

- A. Conditions, malfunctions or damage not resulting from defects in material or workmanship.
- B. Conditions, malfunctions or damage resulting from (1) normal wear and tear, improper installation, improper maintenance, misuse, abuse, negligence, accident or alteration; (2) the use of abrasive or caustic cleaning agents or "no-rinse" cleaning products, or the use of the product in any manner contrary to the product instructions; or (3)

conditions in the home such as excessive water pressure or corrosion.

- C. Labor and other expenses for disconnection, deinstallation, or return of the product for warranty service (including but not limited to proper packaging and shipping costs), or for installation or reinstallation of the product.
- D. Accessories, connected materials and products, or related products not manufactured by Hansgrohe.
- E. Any Hansgrohe or Axor product sold for display purposes.

HANSGROHE SHALL NOT BE LIABLE TO PURCHASER OR ANY OTHER PERSON FOR ANY INCIDENTAL, SPECIAL OR CONSEQUENTIAL DAMAGES, ARISING OUT OF BREACH OF THIS LIMITED WARRANTY.

Some provinces and some states do not allow the exclusion or limitation of incidental or consequential damages, so the above limitation or exclusion may not apply to you.

TO OBTAIN WARRANTY PARTS OR INFORMATION

Contact your Hansgrohe retailer, or contact Technical Service at:

Hansgrohe, Inc.
1492 Bluegrass Lakes Parkway
Alpharetta, GA 30004
Toll-free 800-334-0455

In requesting warranty service, you will need to provide:

1. The sales receipt or other evidence of the date and place of purchase.
2. A description of the problem.
3. Delivery of the product or the defective part, postage prepaid and carefully packed and insured, to:

Hansgrohe, Inc.
1492 Bluegrass Lakes Parkway
Alpharetta, GA 30004
Toll-free 800-334-0455

When warranty service is completed, any repaired or replacement product or part will be returned to you postage prepaid. REVISED MAY 1, 2016.

PRODUCT INSTRUCTIONS AND QUESTIONS

Upon purchase or prior to installation, please carefully inspect your Hansgrohe product for any damage or visible defect. Prior to installing, always carefully study the enclosed instructions on the proper installation and the care and maintenance of this product. If you have questions at any time about the use, installation or performance of your Hansgrohe product, or this warranty, please write us or call us toll-free at 800-334-0455.

hansgrohe

Hansgrohe, Inc. 1490 Bluegrass Lakes Parkway Alpharetta, GA 30004
Tel. 800-334-0455 Fax 770-889-1783

www.hansgrohe-usa.com