

**EN** Assembly instructions

**FR** Instructions de montage

**ES** Instrucciones de montaje

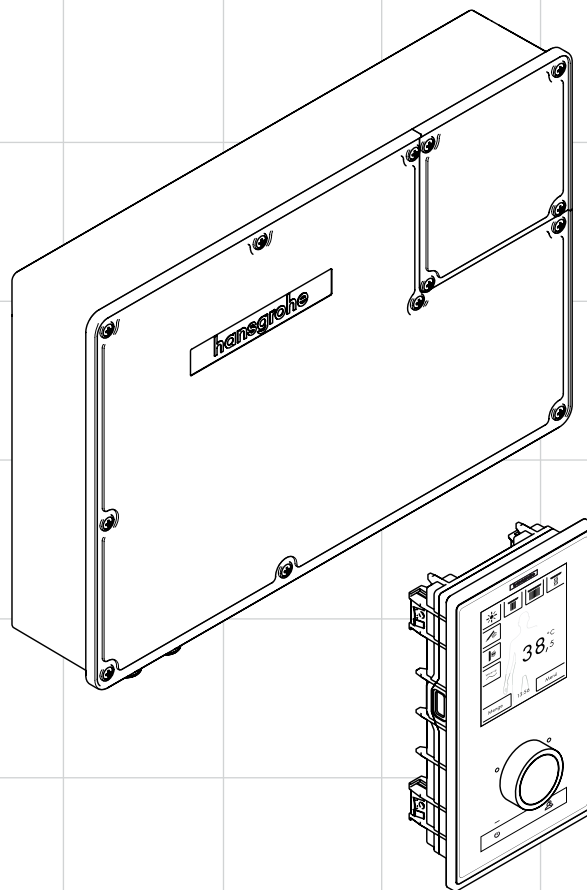

**RainBrain**  
15841XX1

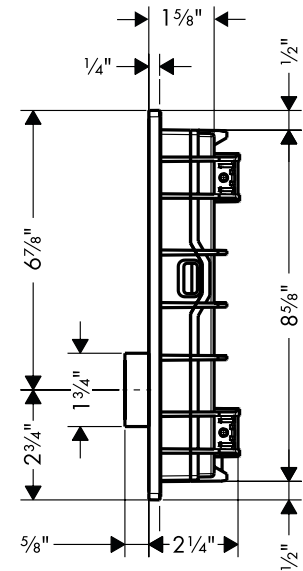
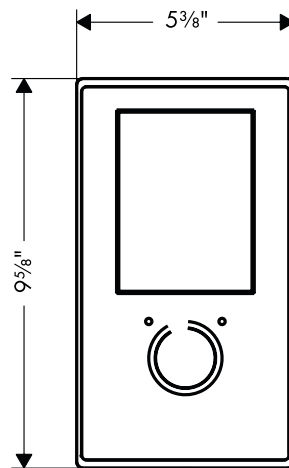
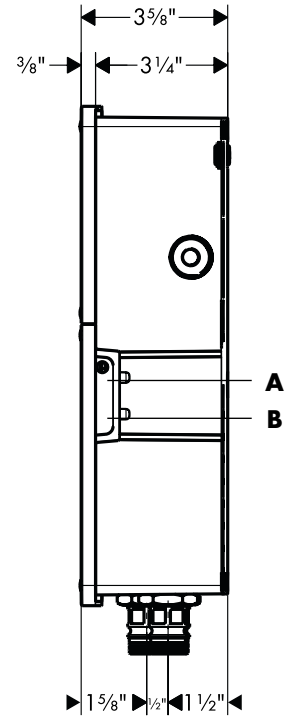
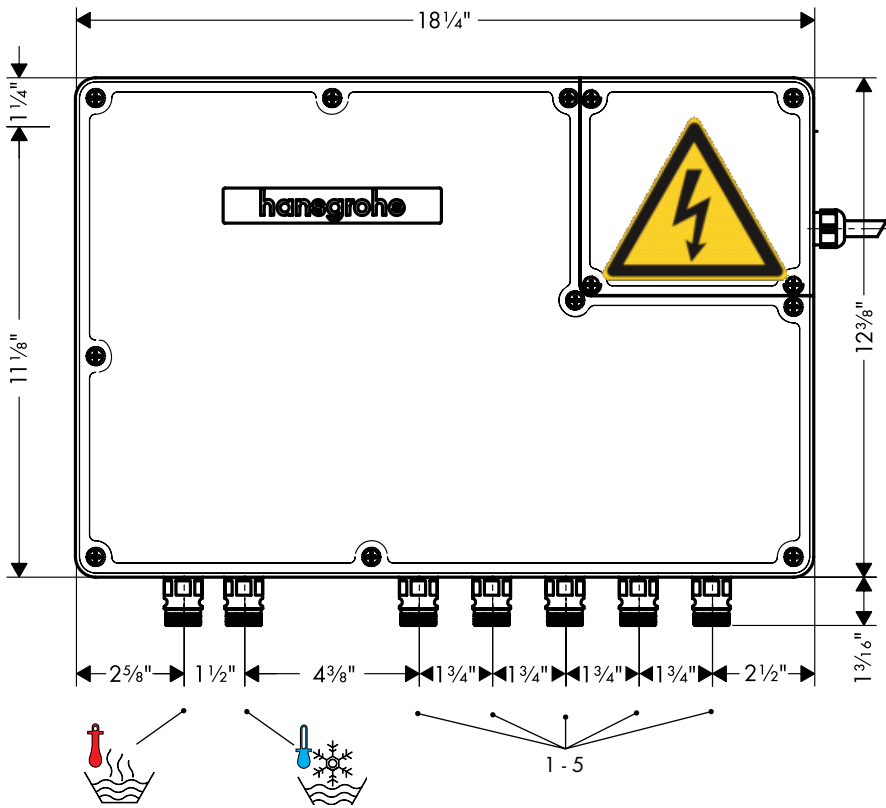
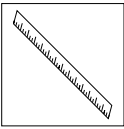

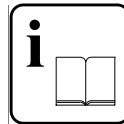





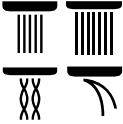

# Symbols Used / Explication des pictogrammes / Simbología

	<b>English</b>	<b>Français</b>	<b>Español</b>
	<b>Warning</b> hazardous electrical voltage	Tension électrique dangereuse	Tensión peligrosa
	<b>Attention!</b> Must be adhered to!	<b>Attention !</b> À respecter à la lettre !	<b>¡Atención!</b> Identifica las instrucciones que se respetarán obligatoriamente
	<b>NOTE</b> Indicates information, whose content is important and must be observed.	<b>REMARQUE</b> Attire l'attention sur des informations dont le contenu est important et doit être respecté.	<b>Nota:</b> Identifica información importante para el correcto funcionamiento.
	<b>Electrician</b>	Monteur-électricien	Electricista
	<b>Installation tool/installation sequence</b>	Outilsage/ordre de montage	Herramienta/orden de tareas de montaje
	<b>Dimensions</b> Installation dimensions	<b>Cotes</b> Cotes de montage	<b>Dimensiones</b> Medidas de montaje
	<b>Specifications</b>	Caractéristiques techniques	Datos técnicos
	<b>Installation diagrams</b>	Plans d'installation	Dibujos de instalación
	<b>Potential equalization</b>	Liaison équipotentielle	Protección equipotencial
	<b>Audio amplifier (not available from Hansgrohe)</b>	Amplificateur audio (pas disponible chez Hansgrohe)	Audio-aplicadores (no forma parte de la gama de productos de Hansgrohe)
	<b>Conduit 3/4" / 1"</b>	<b>Gaine 3/4" / 1"</b>	<b>Tubo vacío 3/4" / 1"</b>
	<b>Conduit for speaker wire, 3/4"</b>	<b>Gaine vide haut-parleur 3/4"</b>	<b>Tubo vacío altavoces 3/4"</b>
	<b>Max. water pressure = 145 PSI</b>	<b>max = 145 PSI</b>	<b>max = 145 PSI</b>
	<b>Hot water supply</b>	Raccord d'eau /Eau chaude	Conexión de agua / agua caliente
	<b>Cold water supply</b>	Raccord d'eau /Eau froide	Conexión de agua/agua fría



## Symbols Used / Explication des pictogrammes / Simbología

	English	Français	Español
	Showerhead	Douchette de tête	Surtidor de ducha de rociado
	Handshower	Douchette à main	Surtidor de ducha de mano
	Bodysprays	Douchette latérale	Surtidores laterales
	No connection	Pas de raccord	sin conexión
	Waterproof sealant	Silicone (sans acide acétique!)	Silicona (sin ácido acético)
	Teflon tape	Fil téflon /chanvre Fermit	Hilo de teflón /cáñamo Fermit

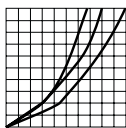

## Technical Information / Données techniques / Datos técnicos

Recommended water pressure	Pression d'eau recommandée	Presión recomendada en servicio	15 - 75 PSI
Max. water pressure	Pression d'eau maximum	Presión en servicio max.	145 PSI
Recommended hot water temp.	Température recommandée d'eau chaude	Temperatura recomendada del agua caliente	120° - 140° F*
Max. hot water temp	Température maximum d'eau chaude	Temperatura del agua caliente max.	176° F*
Flow rate	Capacité nominale	Caudal máximo	11.2 GPM @ 44 PSI
Connections hot - left / cold - right	Conexiones froid côté droit, chaud côté gauche		3/4" NPT

\*Please know and follow all applicable local plumbing codes when setting the temperature on the water heater.

\* Vous devez connaître et respecter tous les codes de plomberie locaux applicables pour le réglage de la température du chauffe-eau.

\*Debe conocer y cumplir todos los códigos locales aplicables para ajustar la temperatura del calentador de agua.



## Installation Considerations

- For best results, Hansgrohe recommends that this unit be installed by a licensed, professional plumber.
- Please read over these instructions thoroughly before beginning installation. Make sure that you have all tools and supplies needed to complete the installation.
- This finish set must be completed with Rainbrain rough 15840181.

 **The terminal block must be installed in a safe, dry, accessible location.**

 **Provide an access panel to allow future maintenance of the terminal block and power box.**

- The power box is included with finish set 15841001. It incorporates a thermostatic mixing valve.
- The maximum flow rate of the Rainbrain is 11.2GPM @ 44 PSI, depending on which shower functions are used. Make sure that the water heater and the drain are adequately sized for your system.

 **The terminal block and power box must be installed horizontally, with the Hansgrohe logo legible. The terminal block and the piping to it must be properly supported.**

- The screws and anchors included with the terminal block are suitable for use in concrete. If another backing material is used, the installer must provide the proper fasteners.
- The flexible plastic conduit included for the control and audio cables may not meet code in all areas. If this is the case in your area, the installer must provide approved conduit.
- To prevent scald injury, the maximum output temperature of the shower valve must be no higher than 120 °F. In Massachusetts, the maximum output temperature can be no higher than 112 °F.

## À prendre en considération pour l'installation

- Pour de meilleurs résultats, Hansgrohe recommande que ce produit soit installé par un plombier professionnel certifié.
- Veuillez lire toutes ces instructions avant de procéder à l'installation. Assurez-vous de disposer de tous les outils et du matériel nécessaires pour l'installation.
- Cette ensemble de finition doit être complétée par le pièce intérieure Rainbrain 15840181.
- Le bloc de raccordement doit être installé dans un endroit sécuritaire, sec et facile d'accès.
- Prévoyez l'installation d'un panneau d'accès pour permettre l'entretien ultérieur du bloc de raccordement et du boîtier d'alimentation.
- Le boîtier d'alimentation est fourni avec l'ensemble de finition 15841001. Il comprend un mélangeur thermostatique.
- Le débit maximal de l'appareil Rainbrain est de 11,2 gpm @ 44 lb/po<sup>2</sup>. Le débit réel dépend des fonctions utilisées dans la douche. Assurez-vous d'utiliser un chauffe-eau et un drain de taille adéquate pour votre système.
- Le bloc de raccordement et le boîtier d'alimentation doivent être installés à l'horizontale, avec le logo Hansgrohe visible. Le bloc

- The touch panel display includes a 2 GB micro SD card. Hansgrohe suggests that the user copy the desired music to the card before installation of the touch panel display. Please see the Music section of the user manual for specific instructions.
- Keep this booklet and the receipt (or other proof of date and place of purchase) for this product in a safe place. The receipt is required should it be necessary to request warranty parts.

## Electrical Service

- The power box (included with finish set 15841001) requires 110 V electrical service. The service must be installed by a licensed electrician in compliance with all applicable local codes.
- GFCI protection must be provided.
- If required by local code, a grounding/potential equalization wire must also be installed.

## Audio Amplifier

- The operating panel sends out a standard signal (L,R, Audio GND) with lever Odbu (0.775 V).
- Finish set 15841001 includes 22 feet of control cable to connect the power box to the touch display, and 22 feet of audio cable to connect the touch display to the amplifier.
- Hansgrohe recommends the use of Axor Starck speakers (part #40874xx1/40876180) in combination with an amplifier (not provided by Hansgrohe).

de raccordement et la tuyauterie raccordée doivent être soutenus correctement.

- Les vis et chevilles fournies avec le bloc de raccordement conviennent pour le béton. Si un autre matériel d'appui est utilisé, l'installateur devra installer les fixations appropriées.
- Il est possible que le conduit en plastique flexible fourni pour le câble de commande et le câble audio ne soit pas conforme aux codes de toutes les régions. En pareil cas, l'installateur doit utiliser un conduit approuvé dans votre région.
- Pour éviter les blessures par brûlure, la température de sortie maximale du robinet de la douche ne doit pas excéder 120 °F (48,9 °C). Dans le Massachusetts, la température de sortie maximale ne doit pas excéder 112 °F (44,5 °C).
- Conservez ce livret et la facture (ou autre preuve de la date et du lieu d'achat) de ce produit dans un endroit sûr. La facture est requise pour les demandes de pièces couvertes par la garantie.



## Branchement électrique

- Le boîtier d'alimentation (fourni avec l'ensemble de finition 15841001) nécessite un branchement électrique 110 V. La prise doit être installée par un électricien certifié, en respectant tous les codes locaux en vigueur.
- Vous devez disposer d'une protection par disjoncteur de fuite à la terre.
- Tous les branchements électriques doivent être effectués par un électricien certifié.
- Assurez-vous de couper l'alimentation électrique avant de travailler sur le boîtier d'alimentation.
- Si les codes locaux l'exigent, installez un conducteur de mise à la terre/d'équipotentialité sur le bloc de raccordement et/ou le boîtier d'alimentation.

## Consideraciones para la instalación

- Para obtener los mejores resultados, Hansgrohe recomienda que la instalación de esta unidad esté a cargo de un plomero profesional matriculado.
- Antes de comenzar la instalación, lea estas instrucciones detenidamente. Asegúrese de tener las herramientas y los insumos necesarios para completar la instalación.
- Este juego de terminación debe completarse con la pieza interior Rainbrain 158401811.

 **El bloque terminal debe instalarse en una ubicación segura, seca y accesible.**

 **Proporcione un panel de acceso para permitir el mantenimiento futuro del bloque terminal y la caja de alimentación.**

- La caja de alimentación se incluye con el juego de terminación 15841001. Incorpora una válvula mezcladora termostática.
- El caudal máximo de Rainbrain es 11.2GPM a 44 PSI. El caudal real depende de la función de ducha que se utiliza. Asegúrese de que el calentador de agua y el desagüe tengan el tamaño adecuado para su sistema.

 **El bloque terminal y la caja de alimentación deben instalarse en posición horizontal, para que el logo de Hansgrohe sea legible. El bloque terminal y su tubería deben contar con un soporte adecuado.**

- Los tornillos y pernos de anclaje incluidos con el bloque terminal son aptos para usar en concreto. Si se usa otro material de soporte, el instalador debe proporcionar los elementos de fijación adecuados.
- El conducto plástico flexible incluido para los cables de audio y control pueden no cumplir con los requisitos de códigos de todas las áreas. Si este es el caso en su área, el instalador debe proporcionar un conducto aprobado.
- Para evitar daños por escaldadura, la temperatura de salida máxima de la válvula de la ducha no debe exceder los 120 °F. En

## Amplificateur audio

- Le panneau de commande achemine un signal standard (L, R, Audio GND) avec un niveau de 0 dBu (0,775 V).
- L'ensemble de finition 15841001 comprend un câble de commande de 22 pi (6,7 m) pour connecter le boîtier d'alimentation à l'afficheur tactile, et un câble audio de 22 pi (6,7 m) pour connecter l'afficheur tactile à l'amplificateur.
- Hansgrohe recommande l'utilisation de haut-parleurs Axor Starck (pièce n° 40874xx1/40876180) avec un amplificateur (non fourni par Hansgrohe).

Massachusetts, la temperatura de salida máxima de la válvula de la ducha no debe exceder los 112 °F.

- Este producto incluye un CD-ROM que contiene todas las instrucciones de instalación y para el usuario. Si necesita copias impresas de esta documentación, contáctese con el Servicio al Cliente de Hansgrohe.
- Conserve este folleto y el recibo (u otro comprobante del lugar y fecha de compra) de este producto en lugar seguro. El recibo se requiere en caso de que sea necesario solicitar piezas bajo garantía.

## Servicio eléctrico

- La caja de alimentación (incluida con el juego de terminación 15841001) requiere de un servicio eléctrico de 110 V. El servicio debe ser instalado por un electricista matriculado que cumpla con todos los códigos locales aplicables.
- Se debe proporcionar protección de ICFT.
- Todas las conexiones eléctricas deben ser realizadas por un electricista matriculado.
- Verifique que la electricidad esté cortada antes de comenzar a trabajar con la caja de alimentación.
- Si lo requiere el código local, instale un cable de ecualización de potencial/a tierra en el bloque terminal o la caja de alimentación.

## Amplificador de audio

- El panel de operación emite una señal estándar (conexión a tierra de audio I y D) con nivel 0dbu (0.775 V).
- El juego de terminación 15841001 incluye un cable de control de 22 pies para conectar la caja de alimentación a la pantalla digital, y un cable de audio de 22 pies para conectar la pantalla digital al amplificador.
- Hansgrohe recomienda el uso de los parlantes Axor Starck (pieza #40874xx1/40876180) junto con un amplificador (no provisto por Hansgrohe).

# Suggested Installation

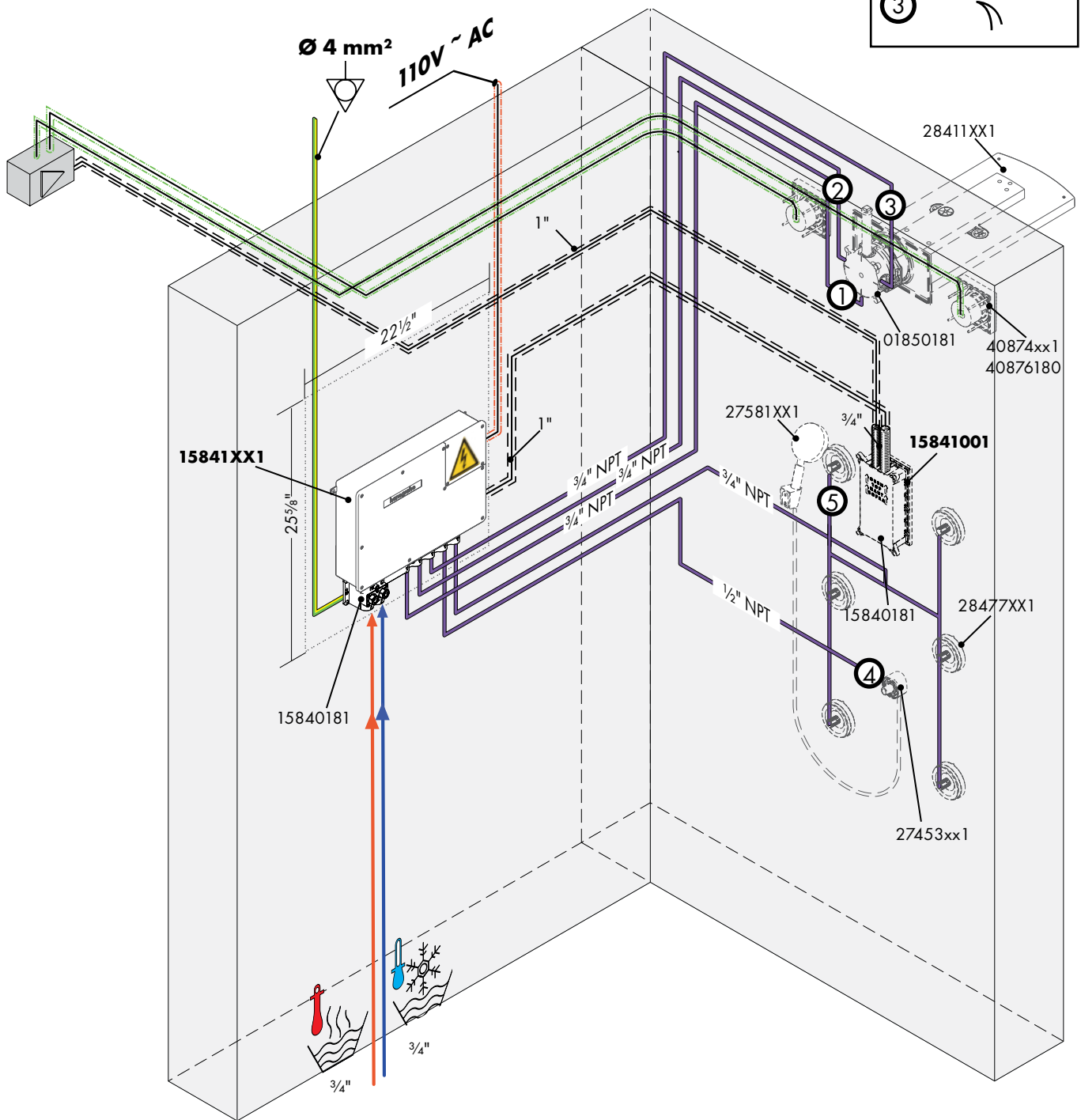
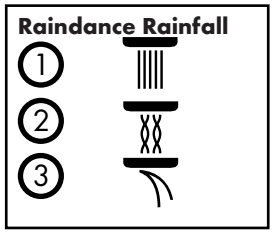
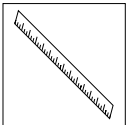

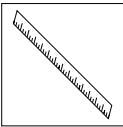

# Suggested Installation

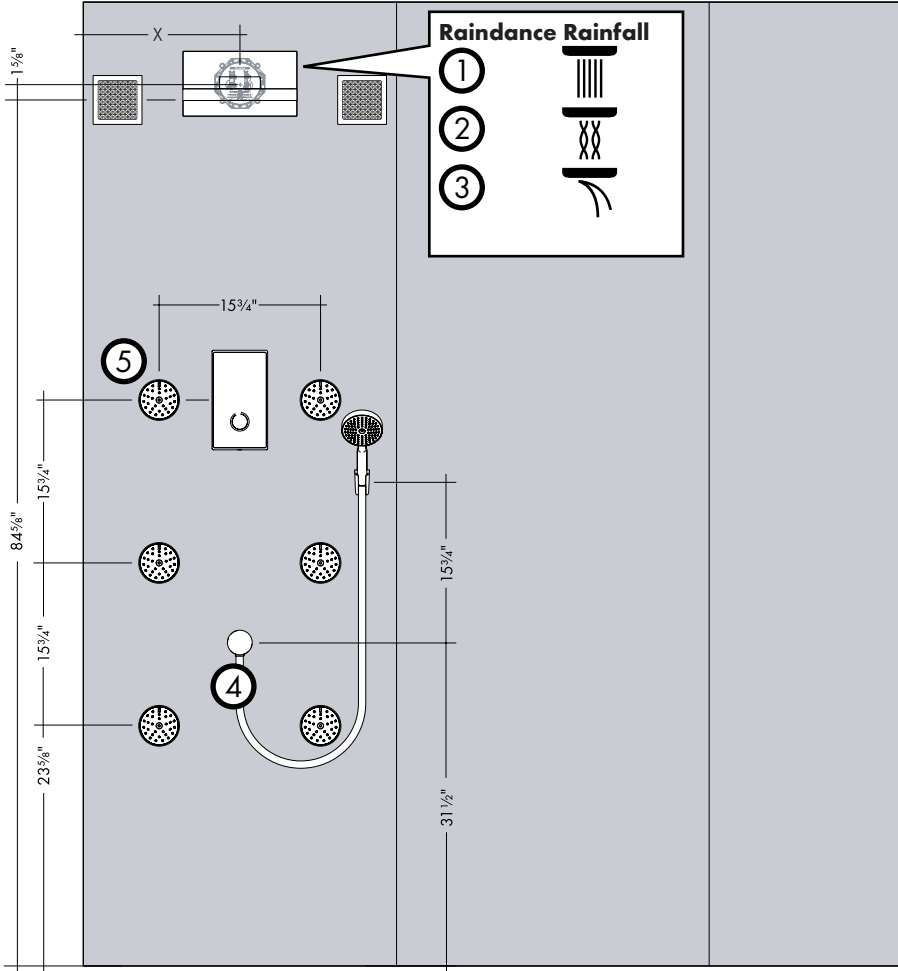
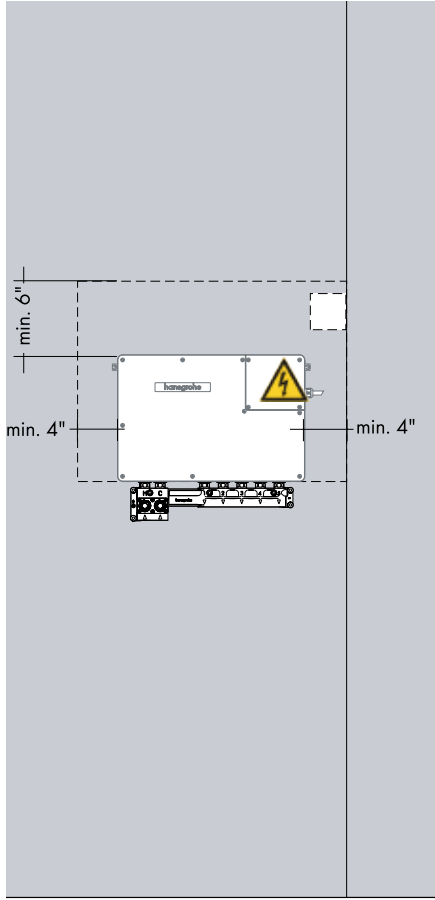



# Wiring Schematic

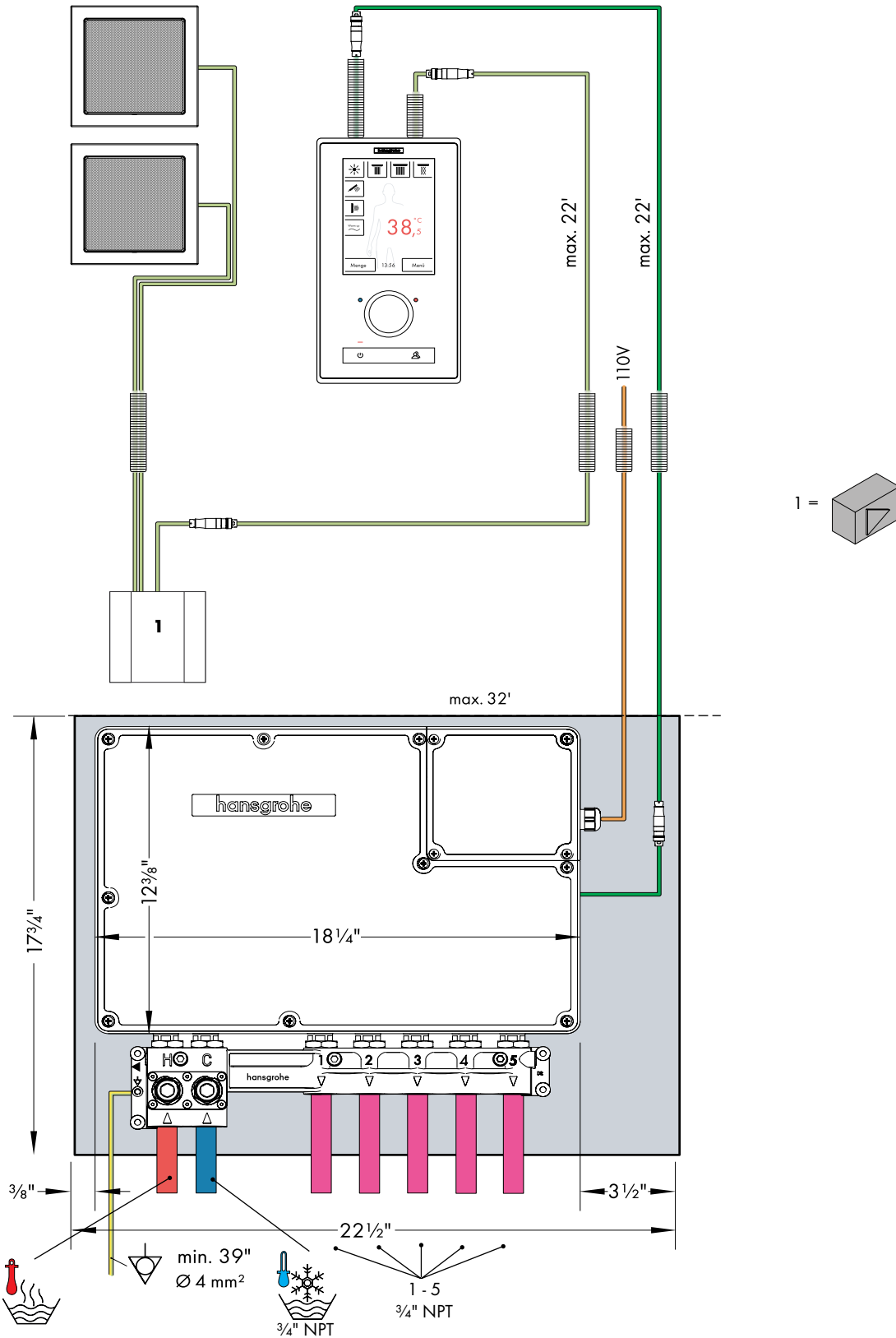



- A** Head shower 3-function
- B** Head shower 2-function
- C** Head shower 1-function

- A** Douchette de tête triple
- B** Douchette de tête double
- C** Douchette de tête simple

- A** Triple surtidor de ducha de rociado
- B** Doble surtidor de ducha de rociado
- C** Surtidor de ducha de rociado

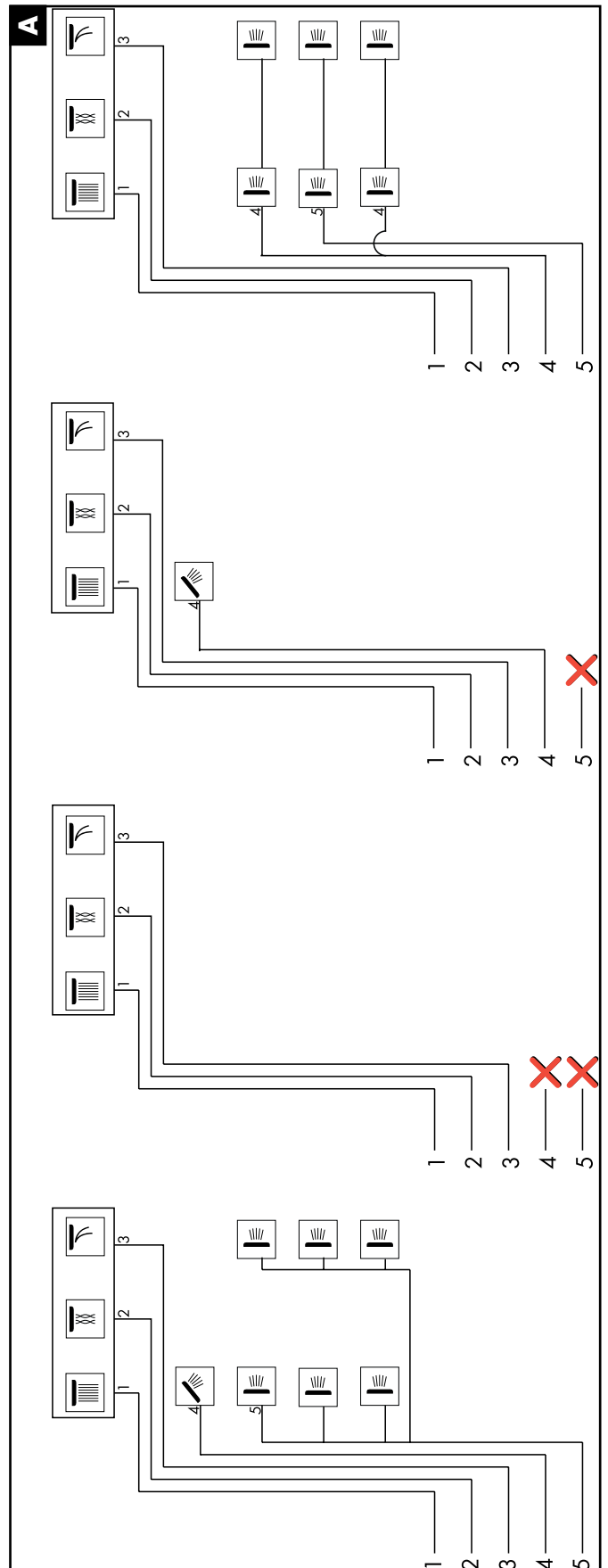
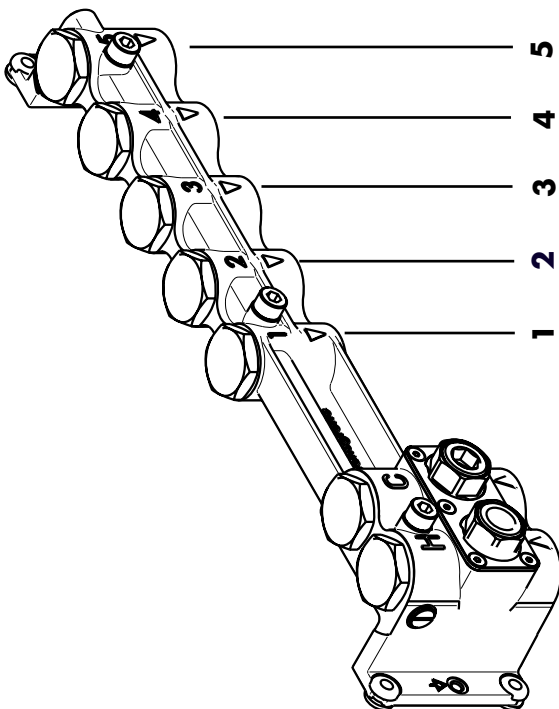

# Possible Configurations

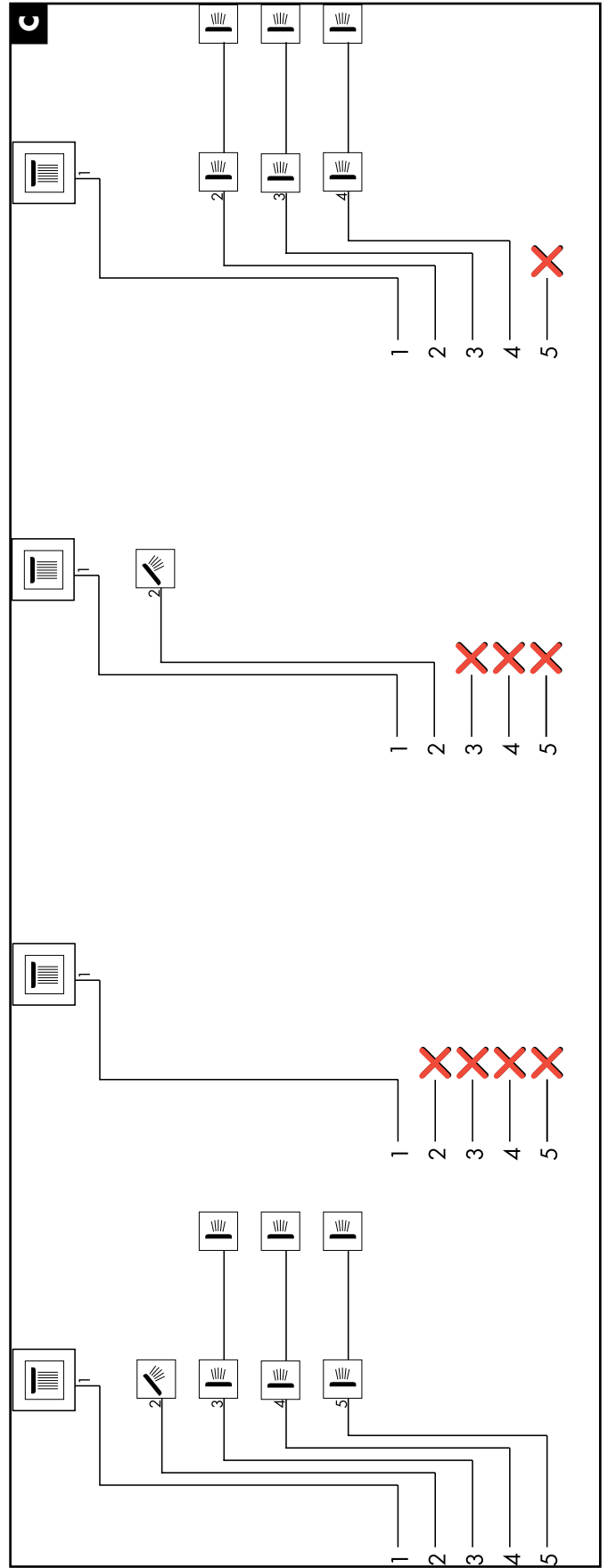
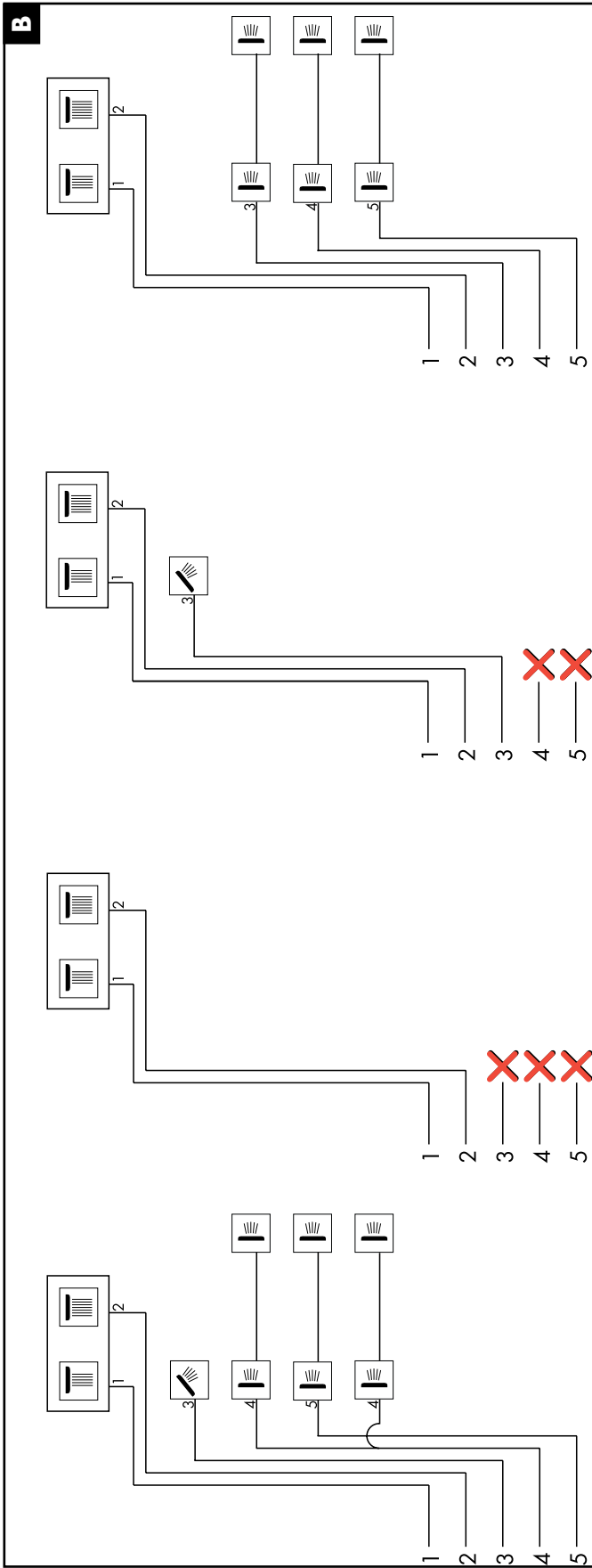

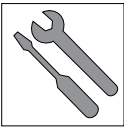

**English**

**Power Box Installation**

**!** Turn the power off at the circuit breaker before beginning.

**!** Turn the water off at the main before beginning.

1 Flush the piping using the following procedure.

**!** Failure to flush the supplies may cause debris damage to the solenoids, which will cause the Rainbrain to malfunction. Debris damage is not covered by the Hansgrohe warranty.

(1) Hold the service valve firmly using a 24 mm wrench (not included).

(2) Remove the service valve covers from the rough using a 12 mm Allen wrench (not included).

(3) Remove the filter elements.

2 Install the covers.

3 Turn the water on.

Flush the hot and cold supplies for at least 5 minutes.

4 Turn the water off at the main.

(1) Hold the service valve firmly using a 24 mm wrench.

(2) Remove the service valve covers.

5 (1) Replace the filter elements.

(2) Replace the service valve covers.

6 Remove the caps from the solenoid connections on the terminal block.

7 Remove the screws.

8 Lightly lubricate the o-rings on the power box inlets using white plumbers grease.

Push the power box firmly into place over the solenoid connections.

9 Connect the rough to the power box using the screws.

10 Install the grounding / potential equalization wire if required by local plumbing code.

11 Remove the access panel from the power box.

12 Loosen the nut.

Connect the power supply to the power box transformer.

13 Tighten the nut.

Replace the access panel.

**Français**

**Installation du boîtier d'alimentation**

**!** Assurez-vous de couper le courant avant de commencer.

**!** Coupez l'eau à la valve principale avant de commencer.

1 Rincez la tuyauterie en suivant la procédure ci-dessous.

**!** Le fait de ne pas rincer les conduites d'alimentation peut causer des dommages aux solénoïdes et compromettre le fonctionnement de l'appareil Rainbrain. Les dommages occasionnés par les débris ne sont pas couverts par la garantie de Hansgrohe.

(1) Maintenez la valve de service fermement à l'aide d'une clé de 24 mm (non comprise).

(2) Retirez les couvercles de la valve de service de la pièce intérieure à l'aide d'une clé hexagonale de 12 mm (non comprise).

(3) Retirez les éléments du filtre.

2 Installez les couvercles.

3 Ouvrez l'eau.

Rincez les conduites d'alimentation en eau chaude et froide pendant au moins 5 minutes.

4 Fermez l'eau à la valve principale.

(1) Maintenez la valve de service fermement à l'aide d'une clé de 24 mm.

(2) Retirez les couvercles de la valve de service.

5 (1) Réinstallez les éléments du filtre.

(2) Réinstallez les couvercles de la valve de service.

6 Retirez les capuchons des raccords de solénoïde sur le bloc de raccordement.

7 Retirez les vis.

8 Lubrifiez légèrement les joints toriques sur les orifices du boîtier d'alimentation en utilisant de la graisse de plomberie blanche.

9 Poussez fermement le boîtier d'alimentation pour le mettre en place sur les raccords de solénoïde.

Connectez la pièce intérieure au boîtier d'alimentation en utilisant les vis.

10 Installez le conducteur de mise à la terre / d'équipotentialité si le code de plomberie local l'exige.

11 Retirez le panneau d'accès du boîtier d'alimentation.

12 Desserrez l'écrou.

Coupez l'alimentation électrique acheminée au boîtier d'alimentation.

**Español**

**Instalación de la caja de alimentación**

**!** Verifique que la electricidad esté cortada antes de comenzar.

**!** Cierre el paso del agua en la entrada del suministro antes de comenzar.

1 Lave la tubería utilizando el siguiente procedimiento.

**!** Si los suministros no se lavan, puede causar daño por residuos a las solenoides, lo que provocará el mal funcionamiento de Rainbrain. Estos daños por residuos no están cubiertos por la garantía de Hansgrohe.

(1) Sostenga la válvula de servicio firmemente con una llave de 24 mm (no incluida).

(2) Retire las tapas de la válvula de servicio de la pieza interior con una llave Allen de 12 mm (no incluida).

(3) Retire los elementos del filtro.

2 Instale las tapas.

3 Abra el suministro de agua.

Lave los suministros de agua caliente y agua fría durante al menos 5 minutos.

4 Cierre el paso del agua en la entrada del suministro.

(1) Sostenga la válvula de servicio firmemente con una llave de 24 mm.

(2) Retire las tapas de la válvula de servicio.

5 (1) Reemplace los elementos del filtro.

(2) Reemplace las tapas de la válvula de servicio.

6 Retire las tapas de las conexiones de solenoides en el bloque terminal.

7 Retire los tornillos.

8 Lubrique levemente los retenes anulares en las entradas de la caja de alimentación utilizando grasa blanca para plomería.

9 Coloque firmemente la caja de alimentación en su lugar sobre las conexiones de solenoides.

Conecte la pieza interior a la caja de alimentación utilizando los tornillos.

10 Instale el cable de ecualización de potencial/a tierra si así lo requiere el código de plomería local.

11 Retire el panel de acceso de la caja de alimentación.

12 Afloje la tuerca.

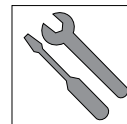

## English

### Touch Panel Installation

- 15** Remove the plaster shield.
- 16** Cut the installation box so that it extends 1/16" - 1/8" outside the surface of the finished wall.
- 17** Seal the wall around the installation box using waterproof sealant.

Failure to seal the wall may lead to water damage.

**18** With the aid of a cable retractor, feed the male end of the control cable through the installation box and conduit. The female end connects to the touch panel. The male end connects to the power box.

**19** Connect the control cable to the power box.

**20** With the aid of a cable retractor, thread the audio cable through the conduit and into the installation box.

The cinch end of the audio cable is too large to thread through the conduit.

**21** Connect the cinch end of the cable to the amplifier (not included). Connect the control wires to the amplifier. The red wire is positive, the black wire is ground.

**22** Press the retaining clips into the holder. Lightly lubricate the retaining clips.

Connect the cables to the touch panel.

**23** Push the touch panel straight into the installation box.

### Touch Panel Removal

**F** Position a screwdriver into the notch below the display.

Lightly drive the display toward the front until you can safely grasp the display with your fingers.



**Do not turn the screwdriver to the side as this may damage the display.**

**G** Pull the display forward using your hands.

Reattach the retaining clips to the display.

## Français

Connectez l'alimentation électrique au transformateur du boîtier d'alimentation.

**13** Serrez l'écrou.

Réinstallez le panneau d'accès.

### Installation du panneau tactile

**15** Retirez le protecteur.

**16** Coupez le boîtier d'installation de façon à ce qu'une partie de 1/16 po à 1/8 po soit à l'extérieur de la surface du mur fini.

**17** Scellez le mur autour du boîtier d'installation à l'aide d'un agent d'étanchéité.

Si le mur n'est pas scellé, l'eau pourrait causer des dommages.

**18** Utilisez un rétracteur de câble pour faire passer l'extrémité mâle du câble de commande dans le boîtier d'installation et le conduit. L'extrémité femelle se connecte au panneau tactile. L'extrémité mâle se connecte au boîtier d'alimentation.

**19** Connectez le câble de commande au boîtier d'alimentation.

**20** Utilisez un rétracteur de câble pour faire passer le câble audio au travers du conduit et dans le boîtier d'installation.

Attention : l'extrémité de connexion du câble audio est trop large pour passer au travers du conduit.

**21** Connectez l'extrémité de connexion du câble à l'amplificateur (non compris). Connectez les fils de commande à l'amplificateur. Le fil rouge est le positif, et le fil noir sert pour la mise à la terre.

**22** Appuyez sur les clips de retenue pour les insérer dans le support. Lubrifiez légèrement les clips de retenue.

Connectez les câbles au panneau tactile.

**23** Poussez le panneau tactile directement dans le boîtier d'installation.

### Pour retirer le panneau tactile:

**F** Placez un tournevis dans l'encoche située sous l'afficheur.

Tirez l'afficheur légèrement vers l'avant jusqu'à ce que vous puissiez le saisir de façon sécuritaire avec vos doigts.



**Ne tournez pas le tournevis sur le côté car vous pourriez endommager l'afficheur.**

**G** Tirez l'afficheur vers l'avant avec vos mains.

Refixez les clips de retenue à l'afficheur.

## Español

Corte la fuente de alimentación de la caja de alimentación.

Conecte la fuente de alimentación al transformador de la caja de alimentación.

**13** Apriete la tuerca.

Reemplace el panel de acceso.

### Instalación del panel digital

**15** Retire el protector de yeso.

**16** Corte la caja de instalación de modo que sobresalga 1/16" - 1/8" de la superficie de la pared terminada.

**17** Selle la pared alrededor de la caja de instalación con un sellador impermeable.

Si no se sella la pared, pueden producirse daños por acción del agua.

**18** Con la ayuda de un retractor de cable, alimente el extremo macho del cable de control a través de la caja de instalación y el conducto. El extremo hembra se conecta al panel digital. El extremo macho se conecta a la caja de alimentación.

**19** Conecte el cable de control a la caja de alimentación.

**20** Con la ayuda de un retractor de cable, enrosque el cable de audio en el conducto y en la caja de instalación.

Precaución: El extremo de sujeción del cable de audio es demasiado grande para enroscar alrededor del conducto.

**21** Conecte el extremo de sujeción del cable al amplificador (no incluido). Conecte los cables de control al amplificador. El cable rojo es positivo, el negro es a tierra.

**22** Coloque las presillas de retención en el soporte. Lubrique levemente las presillas de retención.

Conecte los cables al panel digital.

**23** Presione el panel digital firmemente sobre la caja de instalación.

### Para retirar el panel digital:

**F** Coloque un destornillador en la ranura debajo de la pantalla.

Mueva levemente la pantalla hacia el frente hasta que pueda tomar de forma segura la pantalla con los dedos.



**No gire el destornillador de costado, ya que esto puede dañar la pantalla.**

**G** Tire de la pantalla hacia adelante usando sus manos.

Vuelva a fijar las presillas de retención a la pantalla.

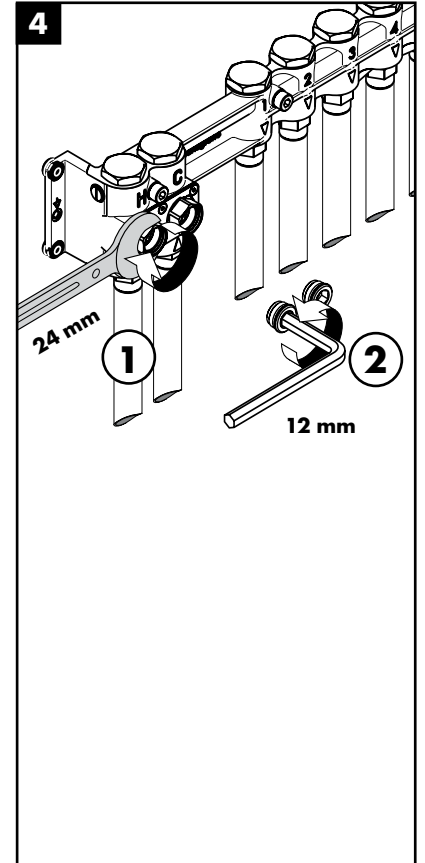
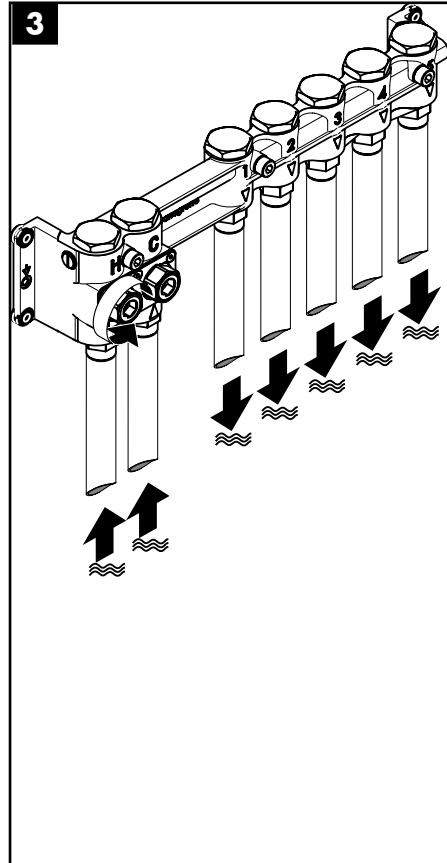
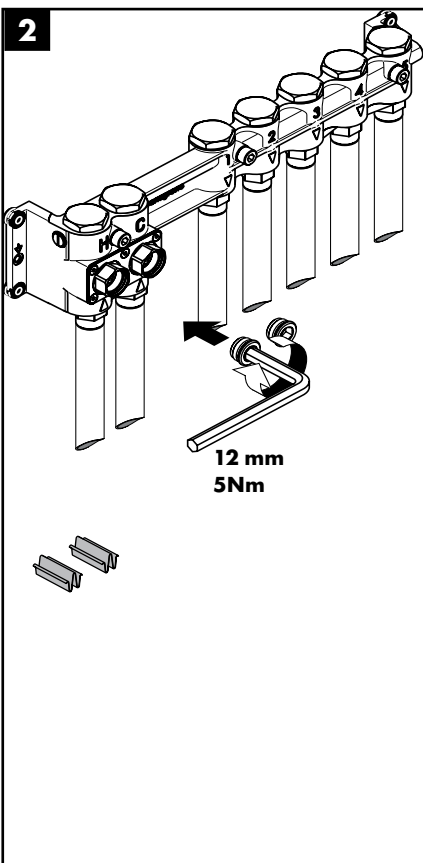
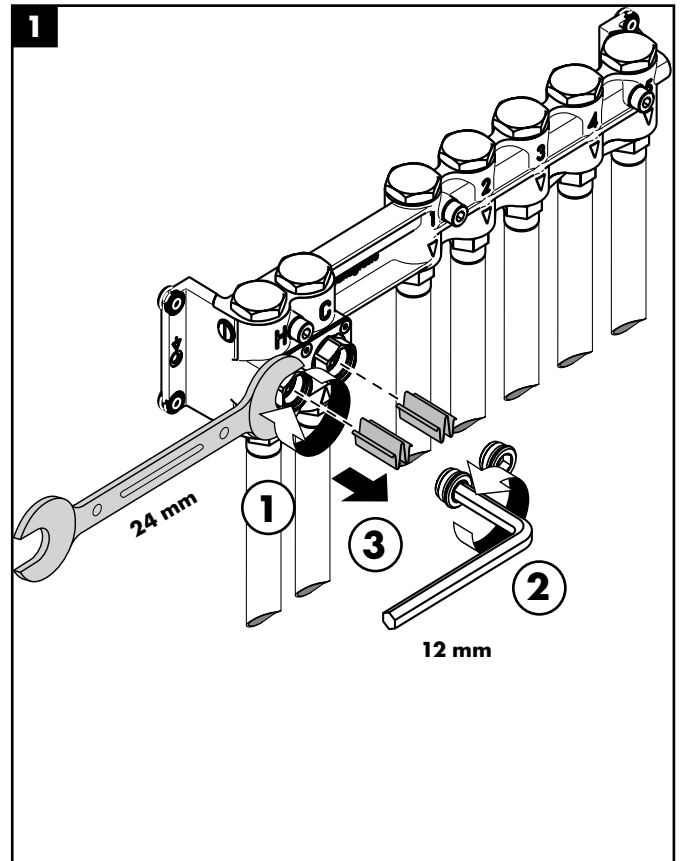
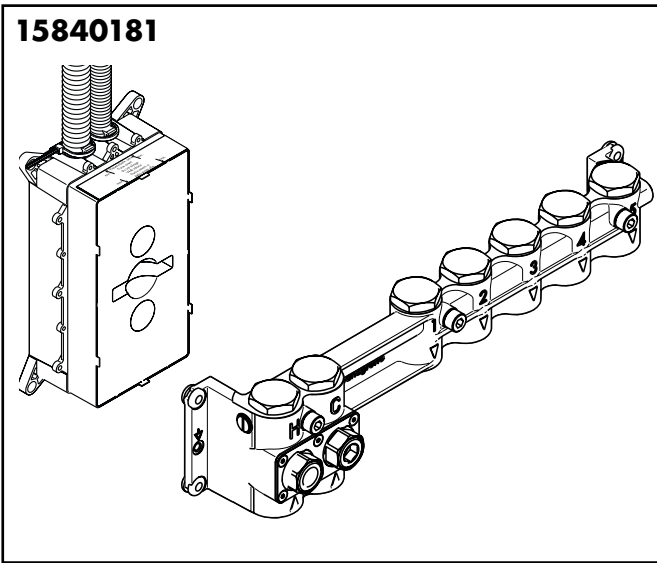
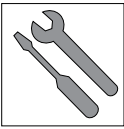

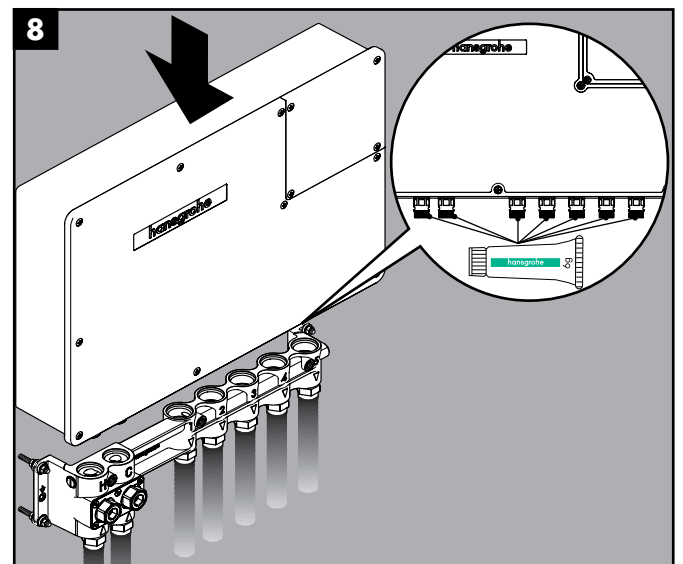
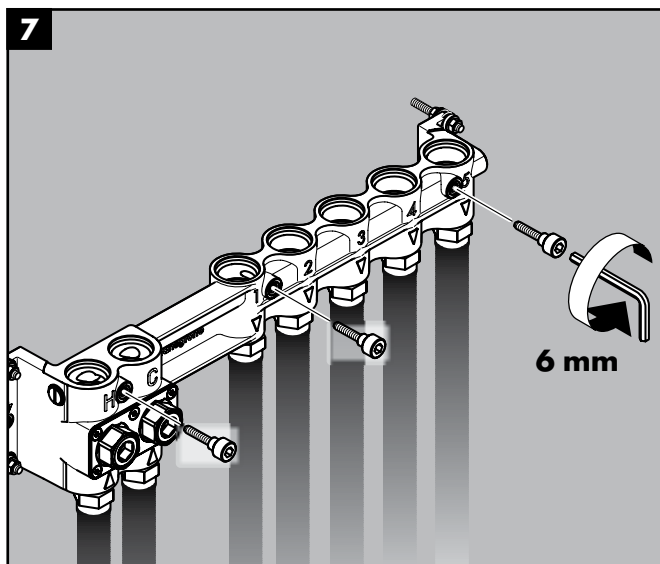
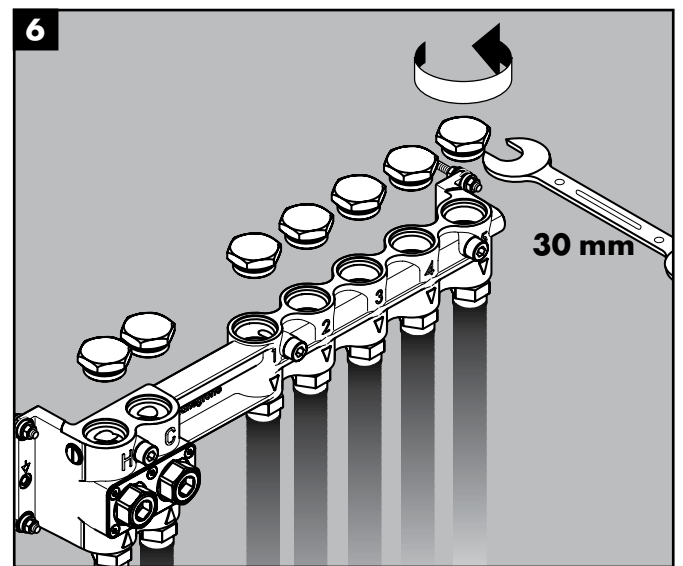
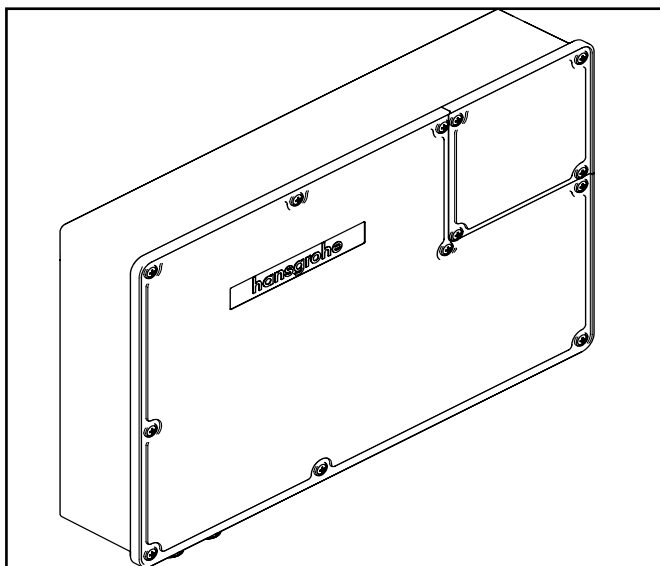
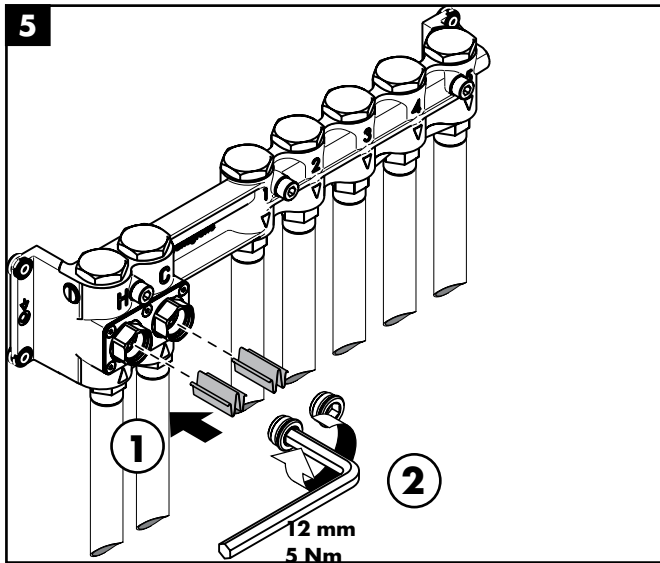
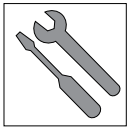

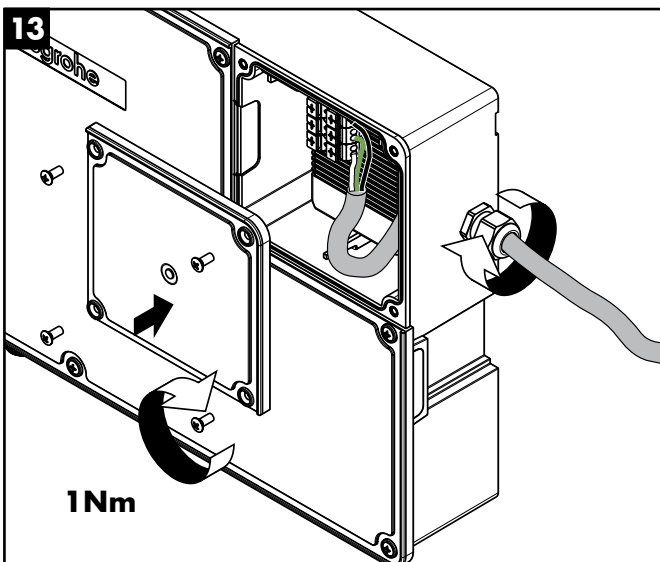
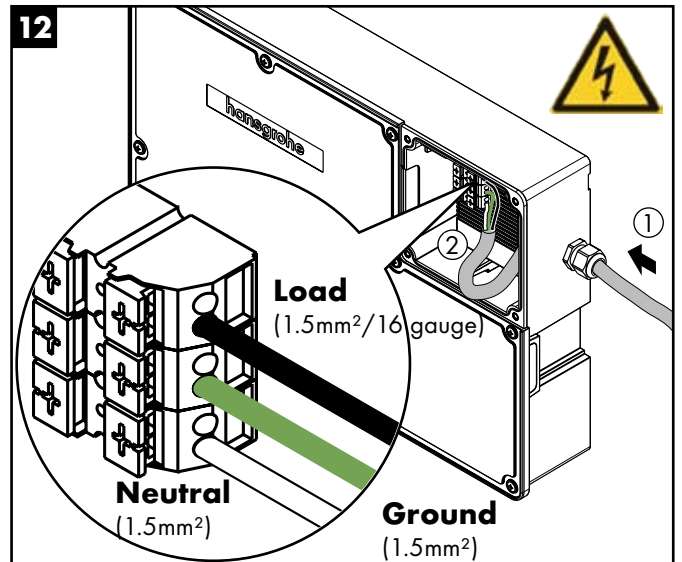
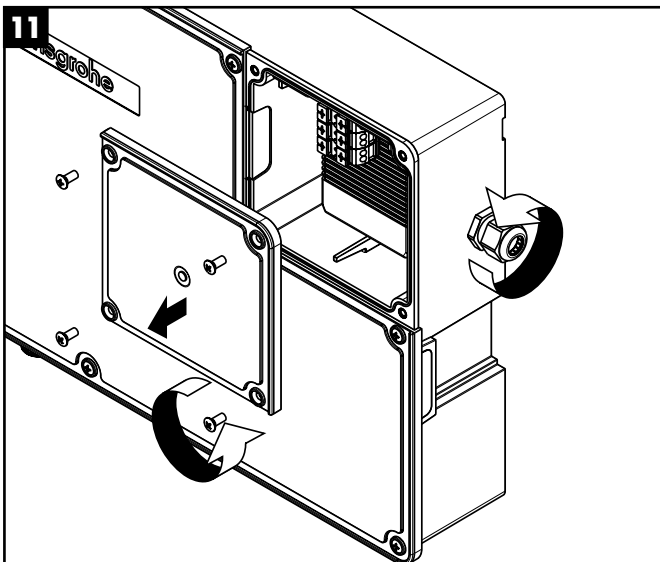
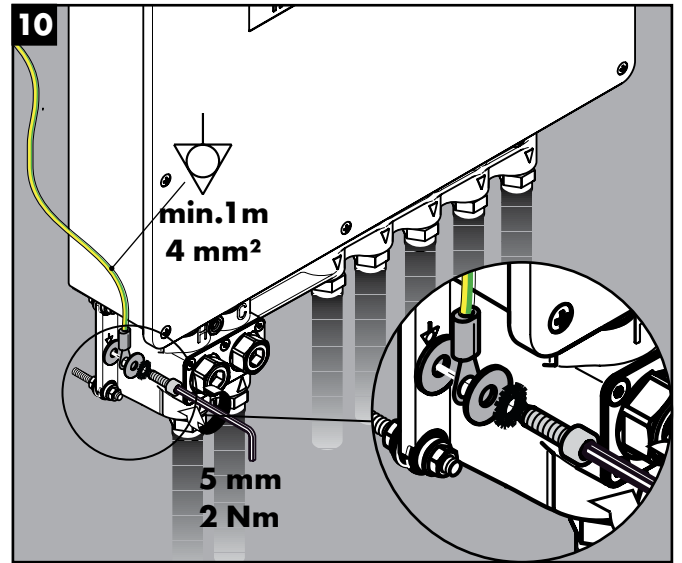
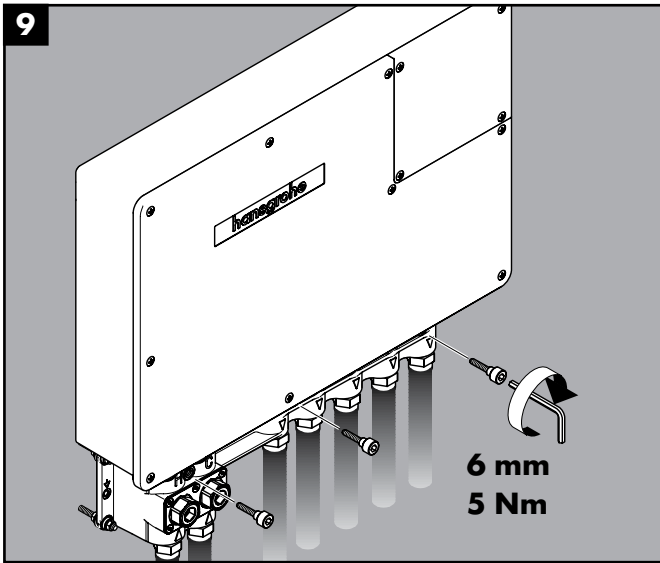
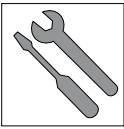



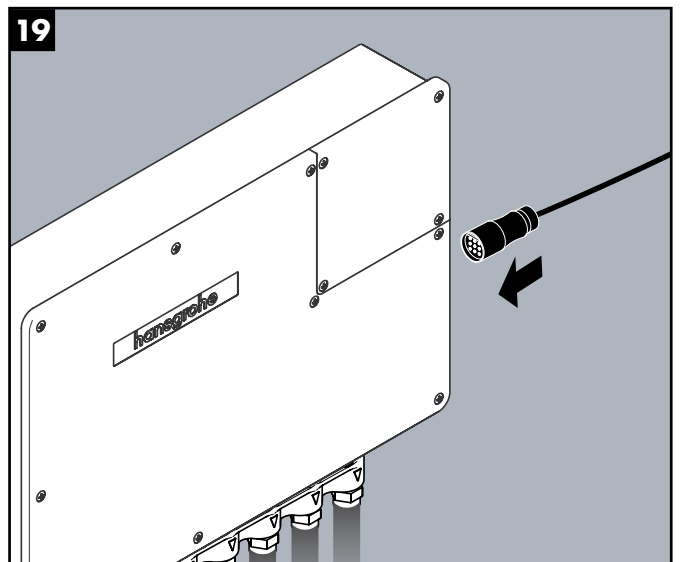
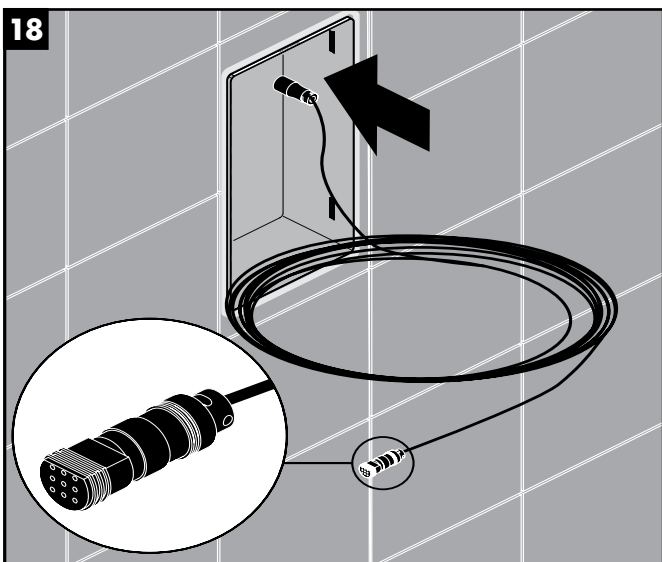
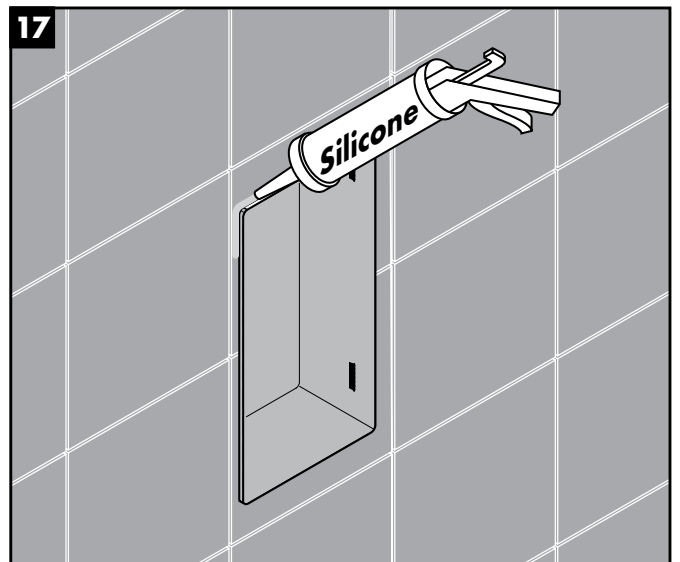
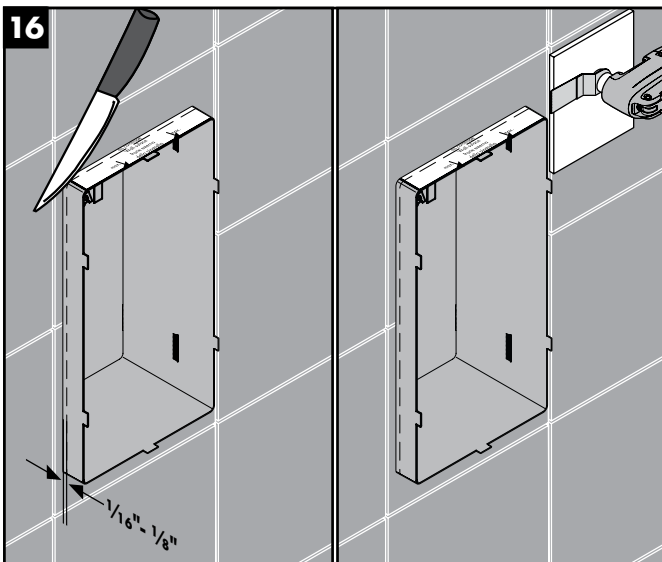
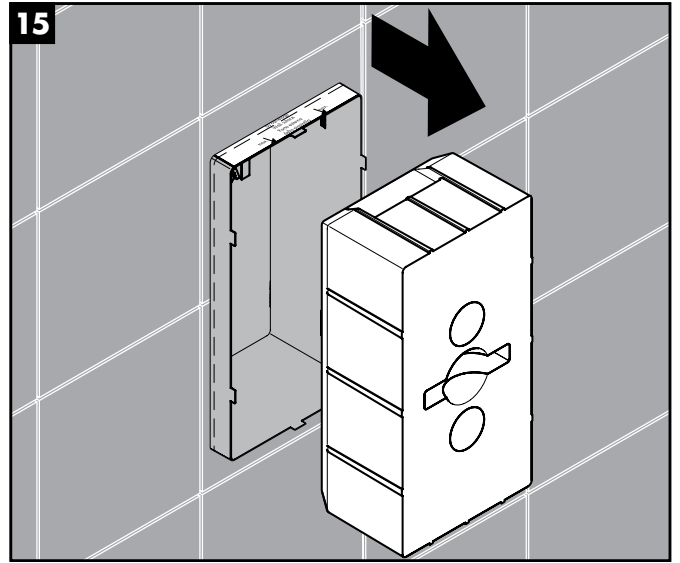
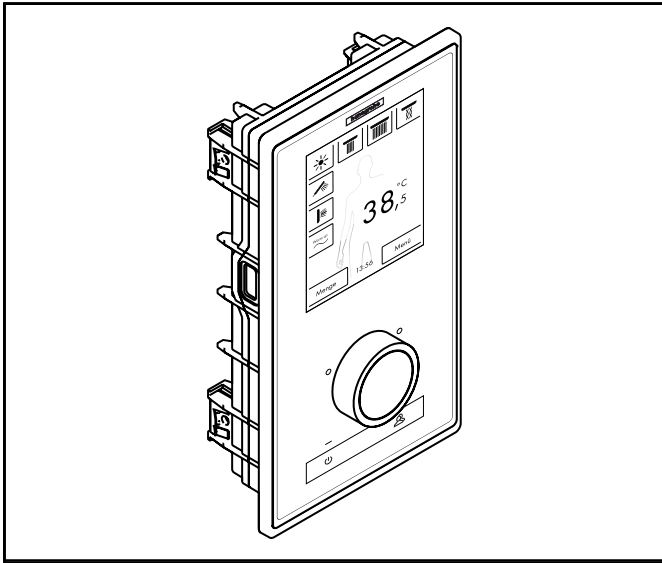
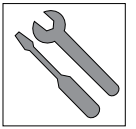

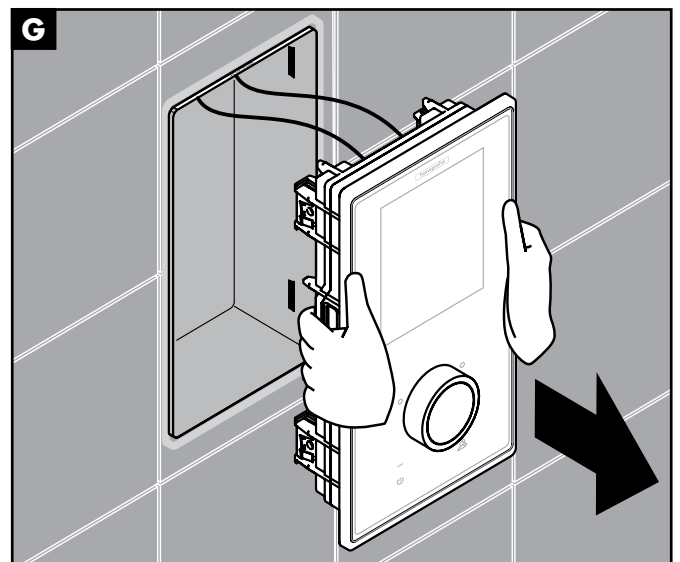
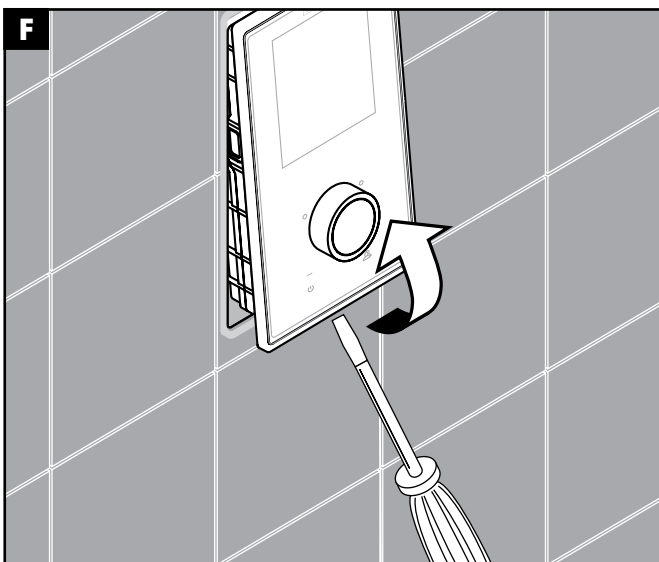
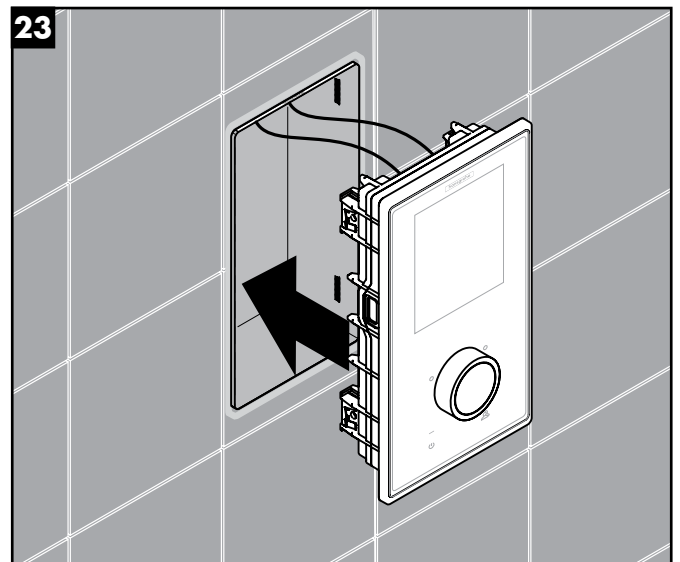
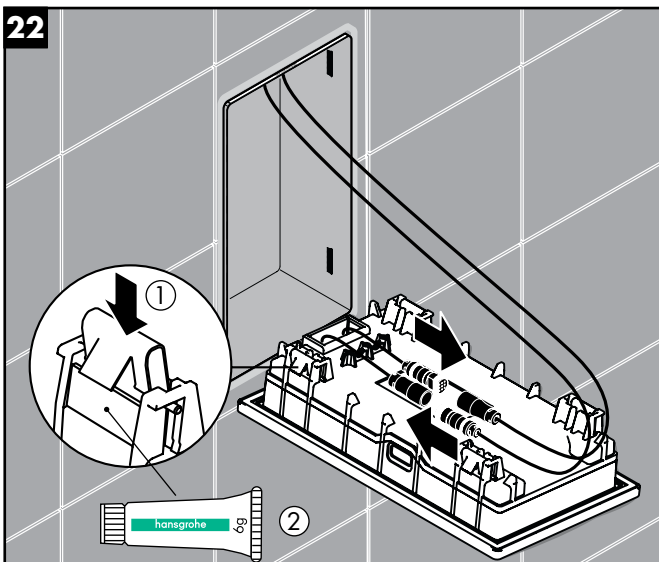
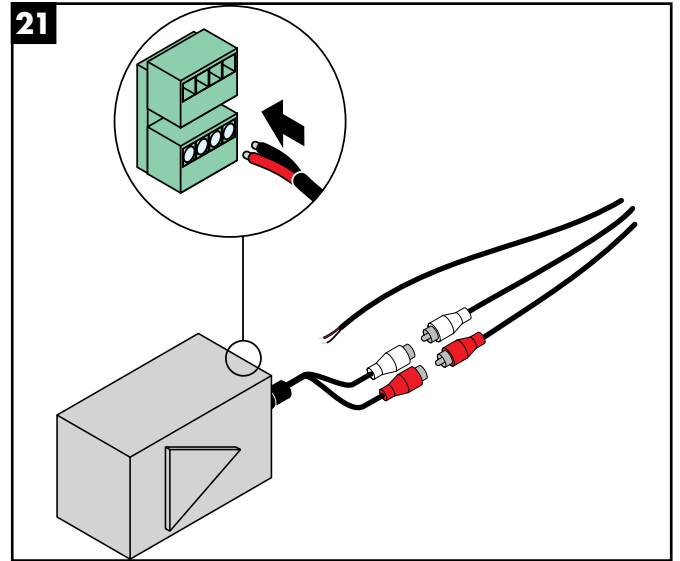
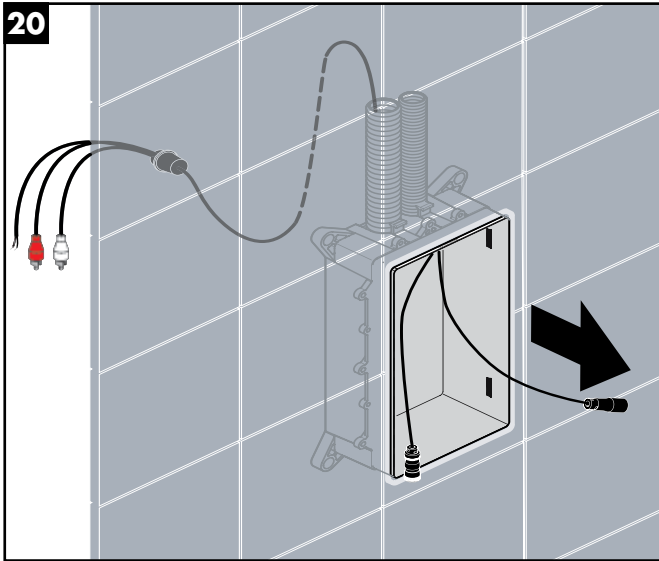
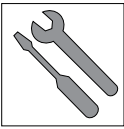

## Initial configuration of Hansgrohe RainBrain

The configuration and the welcome screen are offered every time the device is turned on until the initial installation is performed.

### Configuration with Hansgrohe shower products:

Perform the following steps:

- Figure 1 Select your language by pressing the corresponding button on the display (German is default setting). Press Next.
- Figure 2 Select the desired temperature scale (Celsius or Fahrenheit) on the display. Press Next.
- Figure 3 In the shower assignment screen, press: Hansgrohe products. Press Next.
- Figure 4a/4b Select between showerhead, handshower, and bodysprays step by step from the Hansgrohe assortment. Press Next.
- Figure 5a/5b If applicable, set up music,. Required accessories: an audio amplifier and speakers for music playback.
- Figure 6 Select the desired showers for the cascade function. Press Next.
- Figure 7 Conclude the configuration by selecting OK.
- The basic image will be displayed.

### Configuration with shower products by other manufacturers:

Perform the following steps:

- Figure 1 Select your language by pressing the respective button on the display (German is default setting). Press Next.
- Figure 2 Select the desired temperature scale (Celsius or Fahrenheit) on the display. Press Next.
- Figure 3 In the shower assignment screen, press: Other products. Press Next.
- Figure 8 Select a connection. After this selection, you will be taken to select the appropriate symbol.
- Figure 9a/9b Select the corresponding symbol for the connected fittings and showers (up to 5 possible). Select a blank field for unused connections. Press Next.
- Figure 10 If applicable, set up music. Required accessories: an audio amplifier and speakers for music playback. Press Next.
- Figure 6 Select the desired showers for the cascade function. Press Next.
- Figure 7 Conclude the configuration by selecting OK.
- The basic image will be displayed.

All settings and symbols can be changed later in the settings menu by selecting connection configuration.

The combination must be started with the Start/Stop key on the rotary knob in order not to activate any other functions. All keys must be pressed until the system level is displayed.

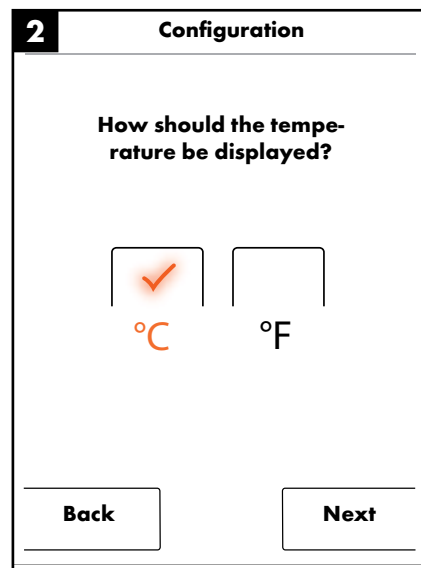
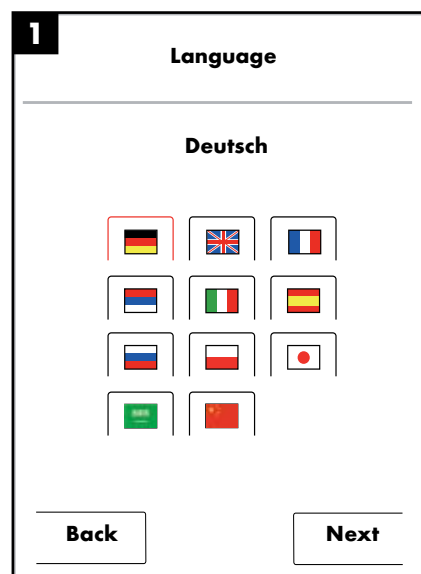
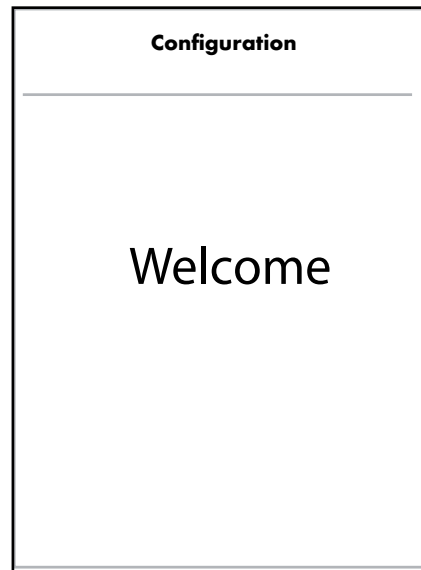

**3** Configuration

How would you like to assign your showers?

Hansgrohe products

Other products

Back Next

**5a** Configuration

Please select your equipment (multiple selections possible)

Hand shower

Side shower

Light

Music

Back Next

**4a** Configuration

Please select a head shower

Rainmaker

Rainfall

Rainfall Mini

Head shower 1 jet

Back ▼ Next

**5b** Configuration

Please select your equipment (multiple selections possible)

Water volume

Back Next

The Water volume setting is only available for model 15842. If you select this option, you will receive an error message.

**4b** Configuration

Please select a head shower

Head shower 2 jet

Showerheaven

Back ▲ Next

**6** Configuration

Which connections should be used to perform the cascade shower

Unused is skipped

Back Next

**7** Configuration

---

Would you like to conclude the configuration?

Modifications are possible on the system level.

Back OK

**9b** Configuration

---

Which symbol should be allocated to connection 1?

	1	2
3	4	5

Back  OK

**8** Configuration

---

Please select your connections

1	2	3
4		
5		

Back Next

**10** Configuration

---

Please select your equipment (multiple selections possible)

 Light

 Music

 Water volume









Back OK

The Water volume setting is only available for model 15842. If you select this option, you will receive an error message.











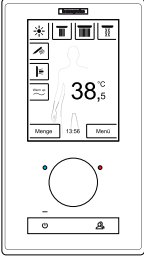

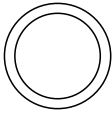
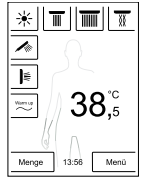

**9a** Configuration

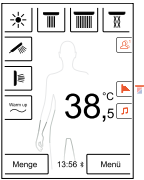









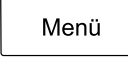



---



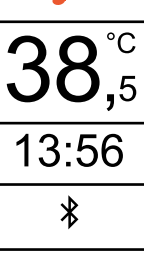







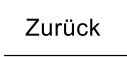

Which symbol should be allocated to connection 1?







		
		
		



Back  OK

	<b>Operating Panel</b>
	On/off switch
	User key
	LED display
	Push button / rotary knob When pressed, all water is stopped from all showers.
	Touch display
	<b>Note:</b> Follow the instructions on the screen.
	<b>Overview of default image</b>
	Light
	1. Showerhead
	2. Showerhead
	3. Showerhead
	Hand shower
	Bodyspray
	Warm up (Preheating the water temperature via all functions.)
	Water volume (for 15842 only)

	To the menu level
	User submenu
	Submenu cascade (changing the individual showers). These are only used to switch off the function on the display. This must be activated in the submenu prior to use.
	Submenu alternating shower (changing temperatures). These are only used to switch off the function on the display. This must be activated in the submenu prior to use.
	Submenu music
	Temperature
	Time
	Bluetooth (only visible while active)
	<b>Wave animation</b> The wave symbol shows that the set nominal temperature has not been reached. This animation will disappear as soon as the temperature is reached.
	<b>Menu level</b>
	Music on/off
	Contrast shower Ein/Aus
	Cascade on/off
	Settings
	Settings of the submenus

	Back
	<b>Temperature setting</b> • Temperature setting via rotary knob
	• Temperature setting by tapping the temperature display
	<b>Switch off scalding protection</b>
	Temperature increase to 42 °C
	Scalding display appears
	<b>Volume setting</b> (for 15842 only)
	<b>User setting</b>
	<b>Warm up</b> (Preheating the water temperature via all consumers.)
	<b>Function sequence overview: Menu level</b>
	<b>Music</b>
	• RainBrain player or external player
	Copy music from PC or mobile phone. Only possible via Bluetooth. As soon as the RainBrain recognises the PC or mobile phone and a file is sent, a display will appear. All running showers are stopped, the light remains switched on

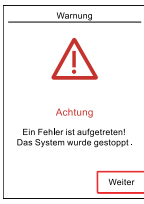
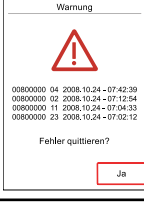
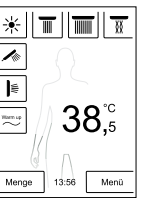
<ol style="list-style-type: none"> <li>Menü</li> <li></li> </ol>	<p><b>Contrast shower</b> While one shower is active, it starts running in contrast shower mode. If no shower is active, the contrast shower mode is turned on but does not start until the user selects a shower.</p>
<ol style="list-style-type: none"> <li>Menü</li> <li></li> </ol>	<p><b>Cascade</b> While one shower is active, it starts running in cascade mode. If no shower is active, the cascade shower mode is turned on but does not start until the user selects a shower.</p>
	<b>Settings</b>
<ol style="list-style-type: none"> <li>Menü</li> <li></li> </ol>	<ul style="list-style-type: none"> <li>User</li> <li>Standard temperature</li> <li>Temperature °C/°F</li> <li>Switch-off time</li> </ul>
<ol style="list-style-type: none"> <li>Menü</li> <li></li> <li></li> </ol>	<ul style="list-style-type: none"> <li>Time and date</li> <li>Display and key sounds</li> <li>Start animation</li> <li>Automatic lights</li> <li>Language</li> <li>Bluetooth connections (the preset PIN is 0000)</li> <li>Factory settings</li> <li>About RainBrain</li> <li>Demo mode</li> </ul>
	<b>System level</b>
	Press for 3 seconds
	<ul style="list-style-type: none"> <li>Configuration wizard</li> <li>Error memory</li> </ul>

	<b>Error display</b>
	If there is danger present, the base image is overwritten with this warning. All showers and other functions are switched off.
	<b>Error display:</b> A maximum of four errors are displayed.
	<b>Three types of errors can occur:</b>
	<b>No danger:</b> Errors that do not represent a hazard to the user or the device. You can still shower, if the selected functions are not effected by this error. The base image appears after acknowledgment. The system will be available again. If you select functions that are effected by this error, the error message will be displayed again. <b>Contact qualified service personnel to fix the error.</b>
	<b>Emergency mode:</b> Even though an error has occurred, you can continue to shower in emergency mode. The emergency run screen will be displayed. Only the hand shower can be selected in this case. <b>Contact qualified service personnel to fix the error.</b>

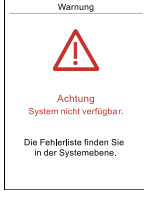
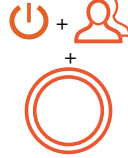
	<p><b>Hazard:</b> Errors that do represent a danger to the user or to the device. The system is not available. With this key combination, the user will get to the system level and to the error list. <b>Contact qualified service personnel to fix the error.</b></p>
	

## Première configuration du RainBrain de Hansgrohe

La configuration ainsi que l'image d'accueil s'affichent après chaque mise en marche de l'appareil, jusqu'à ce que la première installation soit complètement effectuée.

### Configuration avec les pommeaux Hansgrohe :

Les séquences doivent être faites dans l'ordre suivant :

- Fig. 1 Sélectionner la langue. Une pression sur l'écran permet de sélectionner la langue voulue (l'allemand étant pré-réglé). Appuyer sur Suivant.
- Fig. 2 Sélectionner l'unité de température voulue sur l'écran. Appuyer sur Suivant.
- Fig. 3 Sur la page d'affectation des douchettes, sélectionner :  
Produit Hansgrohe. Appuyer sur Suivant.
- Fig. 9a/9b Sélectionner maintenant pas à pas entre la douchette de tête, à main et les douchettes latérales faisant partie de l'assortiment de Hansgrohe. Appuyer sur Suivant.
- Fig. 10 Suivant la configuration de la douche, il est également possible de paramétrer la musique. Accessoires nécessaires : un amplificateur audio et un haut-parleur pour la restitution de musique.
- Fig. 6 Sélectionner les pommeaux voulus pour la fonction cascade. Appuyer sur Suivant.
- Fig. 7 Achever la configuration avec OK.
- L'image de base s'affiche.

### Configuration avec les pommeaux d'autres fabricants :

Les séquences doivent être faites dans l'ordre suivant :

- Fig. 1 Sélectionner la langue. Une pression sur l'écran permet de sélectionner la langue voulue (l'allemand étant pré-réglé). Appuyer sur Suivant.
- Fig. 2 Sélectionner l'unité de température voulue sur l'écran. Appuyer sur Suivant.
- Fig. 3 Sur la page d'affectation des douchettes, sélectionner : Autres produits. Appuyer sur Suivant.
- Fig. 8 Sélectionner un raccord. Après la sélection, un pictogramme approprié est proposé.
- Fig. 9 Sélectionner maintenant un pictogramme pour les raccords et douchettes montés (5 maxi possibles). Pour les raccords non affectés, un champ en blanc est sélectionné. Appuyer sur Suivant.
- Fig. 5a/5b Suivant la configuration de la douche, il est également possible de paramétrer la musique. Accessoires nécessaires : un amplificateur audio et un haut-parleur pour la restitution de musique. Appuyer sur Suivant.
- Fig. 6 Sélectionner les pommeaux voulus pour la fonction cascade. Appuyer sur Suivant.
- Fig. 7 Achever la configuration avec OK.
- L'image de base s'affiche.

Tous les réglages et pictogrammes sélectionnés peuvent être modifiés par la suite dans le menu de réglage, sous configuration de raccord.

Afin de ne pas déclencher d'autres fonctions, la combinaison doit commencer avec la touche marche/arrêt du régulateur rotatif. Toutes les touches doivent rester appuyées jusqu'à ce que le niveau du système apparaisse.

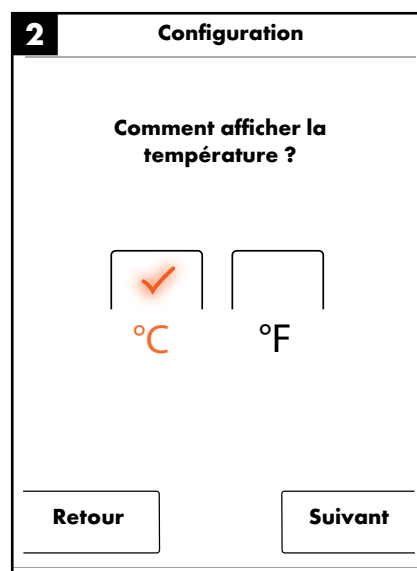
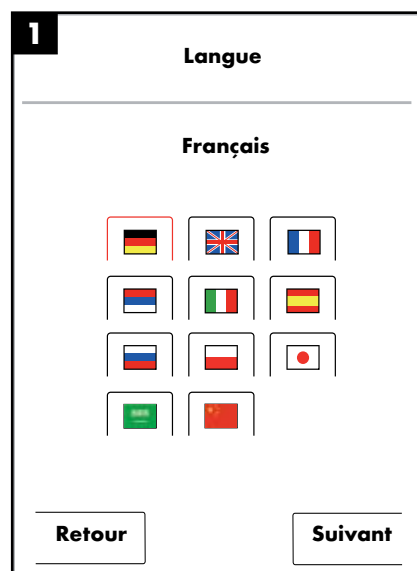
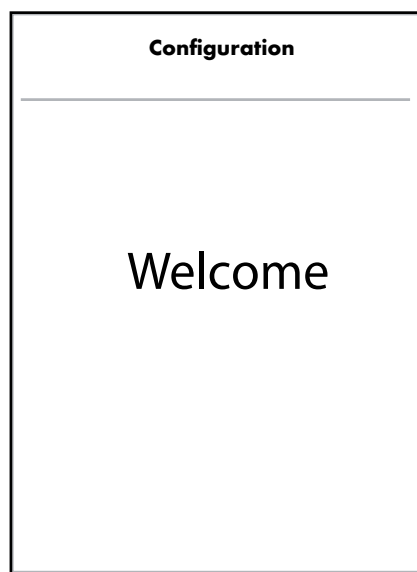



**3** Configuration

Comment voulez-vous affecter vos douchettes ?

Produits Hansgrohe

Autres produits

Retour Suivant

**5a** Configuration

Sélectionnez l'équipement (sélection multiple possible)

Douchette à main

Douchette latérale

Éclairage

Musique

Retour Suivant

**4a** Configuration

Choisissez un pommeau

Rainmaker

Rainfall

Rainfall Mini

Pommeau 1Jet

Retour ▼ Suivant

**5b** Configuration

Sélectionnez l'équipement (sélection multiple possible)

Quantité d'eau

Retour Suivant

Cette option n'est pas disponible. Si vous le choisissez, vous recevrez un message d'erreur.

**4b** Configuration

Choisissez un pommeau

Pommeau 2Jet

Showerheaven

Retour ▲ Suivant

**6** Configuration

Avec quels raccords la cascade doit-elle se faire ?

Saut sans affectation

Retour Suivant

**7** Configuration

Voulez-vous terminer la configuration ?

Des modifications sont possibles au niveau du système.

Retour OK

**9b** Configuration

Quel pictogramme doit être affecté au raccord 1 ?

1     2  
 3     4     5

Retour  OK

**8** Configuration

Sélectionnez vos raccords

1     2     3  
 4  
 5

Retour Suivant

**10** Configuration

Sélectionnez l'équipement (sélection multiple possible)

Éclairage  
 Musique  
 Quantité d'eau











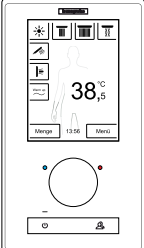

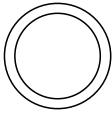
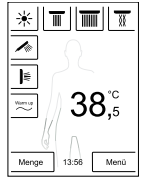

Retour OK

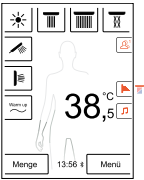



Cette option n'est pas disponible. Si vous le choisissez, vous recevrez un message d'erreur.

**9a** Configuration



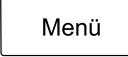







Quel pictogramme doit être affecté au raccord 1 ?





Retour  OK





	<b>Panneau de commande</b>
	Bouton marche/arrêt
	Touche utilisateur
	Affichage à diode
	Bouton poussoir / régulateur rotatif En cas de pression, l'eau de toutes les douchettes est stoppée.
	Écran tactile
	<b>Remarque :</b> Suivez les instructions affichées sur l'écran.
	<b>Vue d'ensemble de l'image d'accueil</b>
	Éclairage
	1. Douchette de tête
	2. Douchette de tête
	3. Douchette de tête
	Douchette à main
	Douchette latérale
	Mise à température (Préchauffage de la température de l'eau à l'aide de tous les consommateurs.)

	Vers le niveau menu
	Sous-menu Utilisateur
	Sous-menu Cascade (passage d'une douchette à l'autre). Elles ne servent sur l'écran qu'à couper la fonction. Ceci doit être préalablement activé dans le sous-menu.
	Sous-menu Douche alternée (températures alternées). Elles ne servent sur l'écran qu'à couper la fonction. Ceci doit être préalablement activé dans le sous-menu.
	Sous-menu Musique
	Température
	Heure
	Bluetooth (seulement visible s'il est activé)
	<b>Vagues en mouvement</b> Les vagues en mouvement indiquent que la température de consigne réglée n'est pas atteinte. Les vagues en mouvement disparaissent dès que la température est atteinte.
	<b>Niveau menu</b>
	Musique marche / arrêt
	Douche alternée marche / arrêt
	Cascade marche / arrêt
	Réglages

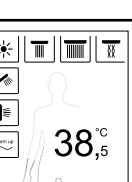
	Paramétrage des sous-menus
	Retour
	<b>Réglage de la température</b>
	• Réglage de la température avec bouton rotatif
	• Réglage de la température par effleurement de l'affichage de température
	<b>Couper la protection contre les brûlures</b>
	Augmentation de la température jusqu'à 42°C (107° F)
	L'affichage de la protection contre les brûlures apparaît
	<b>Réglage de débit</b>
	<b>Réglage utilisateur</b>
	<b>Mise à température</b> (Préchauffage de la température de l'eau à l'aide de tous les consommateurs.)
	<b>Vue d'ensemble des fonctions : Niveau menu</b>
	<b>Musique</b>
	• Player RainBrain ou player externe

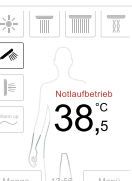
	<p>Copier la musique à partir du PC ou du téléphone portable. (Seulement possible avec Bluetooth.) Un affichage apparaît dès que RainBrain reconnaît le PC ou le téléphone portable et qu'un fichier est transféré. Toutes les douchettes activées sont stoppées, l'éclairage reste allumé.</p>
<p>1. Menü</p>  <p>2. </p>	<p><b>Douche alternée</b> Lorsqu'une douchette est activée, elle démarre en mode douche alternée. Si aucune douchette n'est activée, le mode douche alternée est certes enclenché, mais il ne démarre que dès que l'utilisateur a sélectionné une douchette.</p>
<p>1. Menü</p>  <p>2. </p>	<p><b>Cascade</b> Lorsqu'une douchette est activée, elle démarre en mode cascade. Si aucune douchette n'est activée, le mode cascade est certes enclenché, mais il ne démarre que dès que l'utilisateur a sélectionné une douchette.</p>
	<p><b>Réglages</b></p>
<p>1. Menü</p>  <p>2. </p>	<ul style="list-style-type: none"> <li>• Utilisateur</li> <li>• Température standard</li> <li>• Température °C/°F</li> <li>• Heure de coupure</li> </ul>
<p>1. Menü</p>  <p>2. </p> <p>3. </p>	<ul style="list-style-type: none"> <li>• Heure et date</li> <li>• Écran et touches sonores</li> <li>• Animation de départ</li> <li>• Éclairage automatique</li> <li>• Langue</li> <li>• Liaisons Bluetooth (PIN pré-réglé : 0000)</li> <li>• Réglages d'usine</li> <li>• Au sujet de RainBrain</li> <li>• Mode démonstration</li> </ul>

 	<p><b>Niveau du système</b></p> <p>maintenir 3 secondes appuyées</p>
	<ul style="list-style-type: none"> <li>• Assistant de configuration</li> <li>• Mémoire de défauts</li> </ul>
	<p><b>Affichage de défauts</b></p>
	<p>En présence d'un danger, l'image d'accueil est écrasée par cet avertissement. Toutes les douchettes et les autres fonctions sont coupées.</p>
	<p><b>Affichage de défauts :</b> Quatre défauts sont affichés au maximum.</p>
	<p><b>Trois types de défauts peuvent se présenter :</b></p>
	<p><b>Aucun danger :</b> Défauts ne constituant aucun risque pour l'utilisateur ou l'appareil. Il est possible de poursuivre sa douche si les fonctions sélectionnées ne sont pas touchées par le défaut. L'image d'accueil s'affiche après la validation. Le système redevient disponible. Si des fonctions touchées par le défaut sont sélectionnées, le message de défaut réapparaît. <b>S'adresser à du personnel qualifié pour remédier au défaut.</b></p>

	<p><b>Fonctionnement de secours :</b> Malgré la présence d'une erreur, il est possible de continuer à se doucher en programme de secours. Un écran de secours s'affiche. Seule la douchette à main peut être sélectionnée. <b>S'adresser à du personnel qualifié pour remédier au défaut.</b></p>
  	<p><b>Danger :</b> Défauts constituant un risque pour l'utilisateur ou l'appareil. Le système n'est pas disponible. À l'aide de la combinaison de touches, l'utilisateur accède au niveau du système et à la liste des défauts. <b>S'adresser à du personnel qualifié pour remédier au défaut.</b></p>

## Configuración inicial del Hansgrohe RainBrain

El diálogo de configuración y la ventana de inicio se abren cada vez que se enciende el equipo, hasta que el usuario haya finalizado la configuración inicial.

### Configuración con duchas marca Hansgrohe:

Siga las siguientes instrucciones:

- Fig. 1 Seleccionar el idioma de usuario. Pulsando sobre el display, se puede seleccionar el idioma de usuario deseado (por defecto: alemán). Pulse Siguiente.
- Fig. 2 Seleccione la unidad de temperatura en el display. Pulse Siguiente.
- Fig. 3 En la ventana de asignación de duchas, seleccione Productos Hansgrohe. Pulse Siguiente.
- Fig. 4a/4b Seleccione las opciones deseadas: "ducha fija", "teleducha" y "surtidores laterales" de la gama Hansgrohe. Pulse Siguiente.
- Fig. 5a/5b Según la configuración de la ducha, puede programar música, la iluminación y ajustar el volumen de agua. Accesorios requeridos: Relé de iluminación, artículo 27189000, Powerbox con función de ajuste del volumen de agua, artículo 15842000; 15842400, amplificador y altavoces para la reproducción de música.
- Fig. 6 Seleccione las duchas deseadas para la función de cascada. Pulse Siguiente.
- Fig. 7 Finalice la configuración pulsando OK.
- Se abre la ventana inicial.

### Configuración con duchas de fabricantes ajenos:

Siga las siguientes instrucciones:

- Fig. 1 Seleccionar el idioma de usuario. Pulsando sobre el display, se puede seleccionar el idioma de usuario deseado (por defecto: alemán). Pulse Siguiente.
- Fig. 2 Seleccione la unidad de temperatura en el display. Pulse Siguiente.
- Fig. 3 En la ventana de asignación de duchas, seleccione Otros productos. Pulse Siguiente.
- Fig. 8 Seleccione una conexión. A continuación, se abre la selección de símbolos.
- Fig. 9a/9b Seleccione el símbolo adecuado para las conexiones y duchas existentes (5, como máximo). A las conexiones libres se asignará un campo en blanco. Pulse Siguiente.
- Fig. 5a/5b Según la configuración de la ducha, puede programar música, la iluminación y ajustar el volumen de agua. Accesorios requeridos: Relé de iluminación, artículo 27189000, Powerbox con función de ajuste del volumen de agua, artículo 15842000; 15842400, amplificador y altavoces para la reproducción de música. Pulse Siguiente.
- Fig. 6 Seleccione las duchas deseadas para la función de cascada. Pulse Siguiente.
- Fig. 7 Finalice la configuración pulsando OK.
- Se abre la ventana inicial.

Todos los ajustes, así como la asignación de símbolos se pueden modificar en otro momento por medio del menú de ajustes, opción de configuración de conexiones.

La combinación se iniciará con la tecla Start/Stop del regulador giratorio para no activar ninguna otra función. Mantenga pulsadas todas las teclas, hasta que se abre la ventana de sistema.

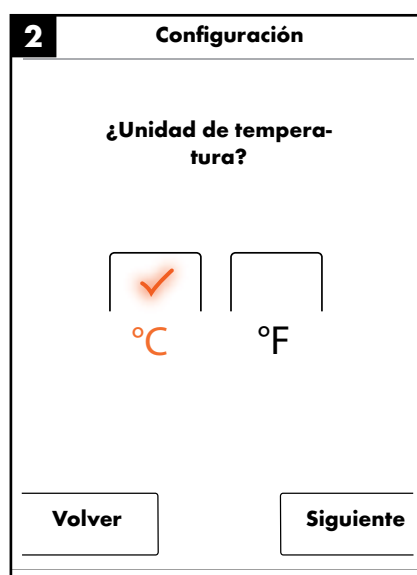
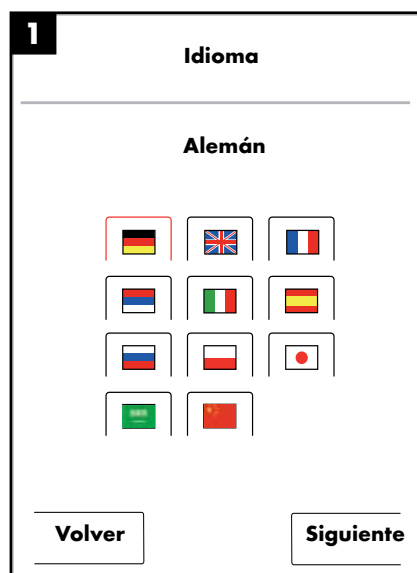
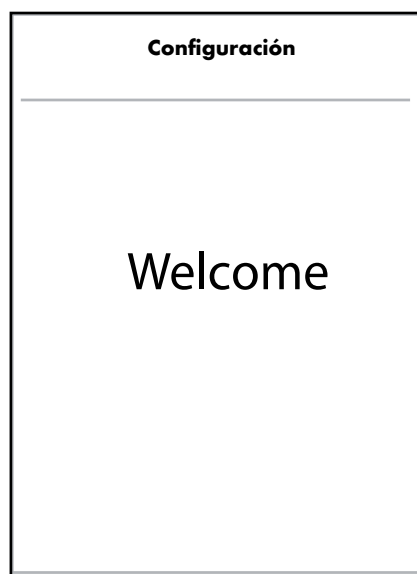

**3 Configuración**

¿Cómo desea asignar las duchas?

Productos Hansgrohe.

Otros productos.

Volver Siguiete

**5a Configuración**

Por favor, ¡seleccione el equipamiento (varias opciones)!

Surtidor de ducha de mano

Surtidores laterales

Iluminación

Música

Volver Siguiete

**4a Configuración**

Por favor, ¡seleccione un surtidor de ducha de rociado!

Rainmaker

Rainfall

Rainfall Mini

Surtidor de ducha de rociado 1Jet

Volver ▼ Siguiete

**5b Configuración**

Por favor, ¡seleccione el equipamiento (varias opciones)!

Volumen de agua

Volver Siguiete

Esta opción no está disponible. Si usted lo selecciona, recibirá un mensaje de error.

**4b Configuración**

Por favor, ¡seleccione un surtidor de ducha de rociado!

Surtidor de ducha de rociado 2Jet

Showerheaven

Volver ▲ Siguiete

**6 Configuración**

¿Conexiones de cascada?

Se sobresaltan los valores sin asignar

Volver Siguiete

**7** Configuración

¿Desea finalizar la configuración?

Para cualquier cambio, abra la ventana de sistema.

Volver Ok

**9b** Configuración

¿Símbolo conexión 1?

	1	2
3	4	5

Volver  Ok

**8** Configuración

Por favor, ¡seleccione las conexiones deseadas!

1	2	3
4		
5		

Volver Siguiete

**10** Configuración

Por favor, ¡seleccione el equipamiento (varias opciones)!

 Iluminación

 Música









 Volumen de agua

Volver OK











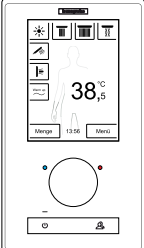

Esta opción no está disponible. Si usted lo selecciona, recibirá un mensaje de error.

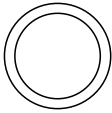
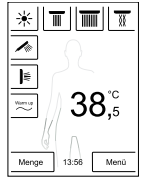
**9a** Configuración

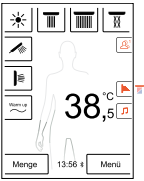









¿Símbolo conexión 1?

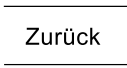



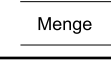

Volver  Ok

	<b>Campo de controles</b>
	Interruptor ON/OFF
	Tecla de usuario
	Indicador LED
	Pulsador / selector giratorio Pulsar para cortar el agua en todas las duchas.
	Panel táctil
	<b>Nota:</b> Siga las instrucciones en el display.
	<b>Sinopsis de la ventana inicial</b>
	Iluminación
	1. Surtidor de ducha de rociado
	2. Surtidor de ducha de rociado
	3. Surtidor de ducha de rociado
	Surtidor de ducha de mano
	Surtidores laterales



	Warm up (precalentamiento del agua en todos los consumidores)
	Acceder nivel de menús
	Submenú de usuario
	Submenú de cascada (cambiar entre duchas individuales). En el display, únicamente permiten desactivar la función. Activar antes en el submenú.
	Submenú de ducha flexible (cambio de temperaturas). En el display, únicamente permiten desactivar la función. Activar antes en el submenú.
	Submenú de música
	Temperatura
	Hora
	Bluetooth (sólo visible cuando la función haya sido activada)
	<b>Gráfico de onda</b> El gráfico de onda señala que no se ha alcanzado aún la temperatura nominal ajustada. El gráfico de onda desaparece al alcanzar dicha temperatura.
	<b>Nivel de menús</b>
	Música ON/OFF
	Ducha flexible ON/OFF
	Cascada ON/OFF

	Ajustes
	Opciones de ajuste en los submenús
	Volver
	<b>Ajuste de temperatura</b>
	• Ajuste de temperatura por medio del selector giratorio.
	• Ajuste de temperatura tocando el indicador de temperatura con el dedo.
	<b>Desactivar el tope de seguridad</b>
	1. Se alcanza una temperatura máxima de 42°C (107° F)
	2. Se apaga el indicador del tope de seguridad
	<b>Ajuste del volumen</b>
	<b>Ajustes del usuario</b>
	<b>Warm up</b> (precalentamiento del agua en todos los consumidores)
	<b>Sinopsis de la secuencia de funciones: Nivel de menús</b>
	<b>Música</b>
	• Reproductor Rain-Brain o reproductor Extern
	

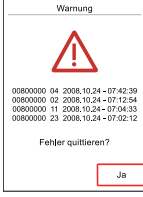

	<p>Cargar archivos de música desde un PC o móvil (sólo con opción de Bluetooth). Una vez que el RainBrain haya detectado el PC o el móvil y se transmite un archivo, aparece un correspondiente mensaje del sistema. Se apagan todas las duchas, pero no la iluminación.</p>
<p>1. Menü</p> <p>2. </p>	<p><b>Ducha flexible</b> Activada un surtidor de ducha, éste funciona en modo de ducha flexible. De lo contrario, se activa el modo de ducha flexible pero permanece inoperativo hasta que el usuario seleccione un surtidor de ducha.</p>
<p>1. Menü</p> <p>2. </p>	<p><b>Cascada</b> Activada un surtidor de ducha, éste funciona en modo de cascada. De lo contrario, se activa el modo de cascada pero permanece inoperativo hasta que el usuario seleccione un surtidor de ducha.</p>
	<p><b>Ajustes</b></p>
<p>1. Menü</p> <p>2. </p>	<ul style="list-style-type: none"> <li>• Usuario</li> <li>• Temperatura estándar</li> <li>• Temperatura °C/°F</li> <li>• Tiempo de desconexión</li> </ul>
<p>1. Menü</p> <p>2. </p> <p>3. </p>	<ul style="list-style-type: none"> <li>• Fecha y hora</li> <li>• Display y sonidos de teclas</li> <li>• Gráfico animado de inicio</li> <li>• Iluminación automática</li> <li>• Idioma</li> <li>• Conexiones de Bluetooth (por defecto, PIN 0000)</li> <li>• Ajustes de fábrica</li> <li>• Sobre RainBrain</li> <li>• Modo de demostración</li> </ul>

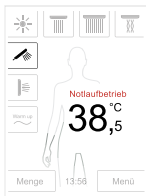
	<p><b>Nivel de sistema</b> Pulsar para 3 segundos</p>
	<ul style="list-style-type: none"> <li>• Asistente de configuración</li> <li>• Memoria de fallos</li> </ul>
	<p><b>Indicador de fallos</b></p>
	<p>En caso de peligro, el mensaje del sistema aparece en primer plano. Se desactivan todos los surtidores y funciones.</p>
	<p><b>Indicador de fallos:</b> como máximo, se visualizan cuatro mensajes de fallo.</p>
	<p><b>Existen tres tipos de fallos:</b></p>
	<p><b>Fallos no peligrosos:</b> Fallos que no suponen ningún peligro de daños personales o materiales. Se puede utilizar la ducha, siempre que las funciones activadas estén operativas. Confirmado el fallo, se abre la ventana inicial. El sistema está disponible. Al activar una función no disponible en consecuencia del fallo, se vuelve a visualizar el mensaje de fallo. <b>Para eliminar el fallo, contacte con personal especialista.</b></p>

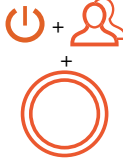
	<p><b>Funcionamiento en modo reserva:</b> A pesar de que se haya producido un fallo, se puede utilizar la ducha en el modo de reserva. En tal caso, se abre la ventana del modo de reserva. Únicamente se puede utilizar el surtidor de ducha de mano. <b>Para eliminar el fallo, contacte con personal especialista.</b></p>
 	<p><b>Peligro:</b> Fallos que pueden poner en peligro la integridad de personas o del producto. El sistema queda completamente desactivado. Pulsando la combinación de teclas, se abre el nivel de sistema y la lista de fallos. <b>Para eliminar el fallo, contacte con personal especialista.</b></p>



# Replacement Parts / Pièces détachées / Repuestos

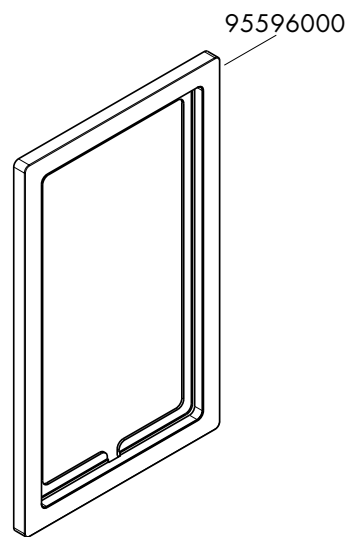
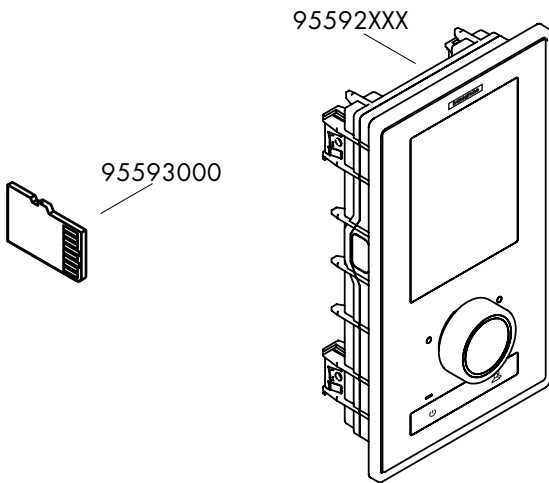
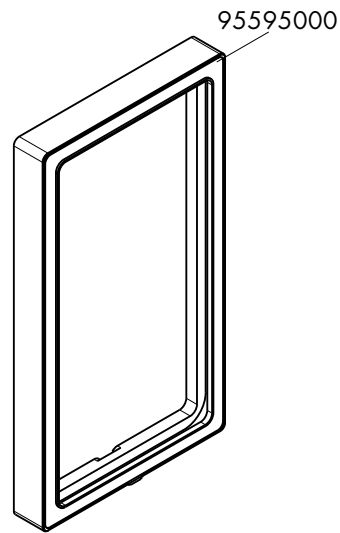
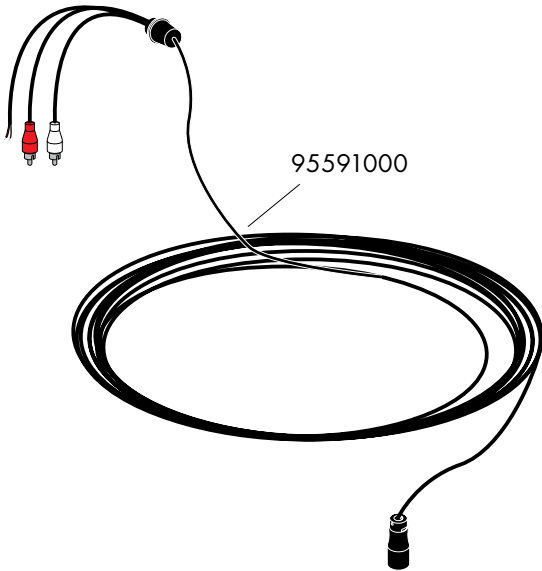
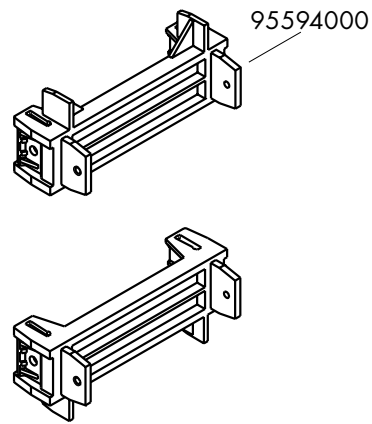

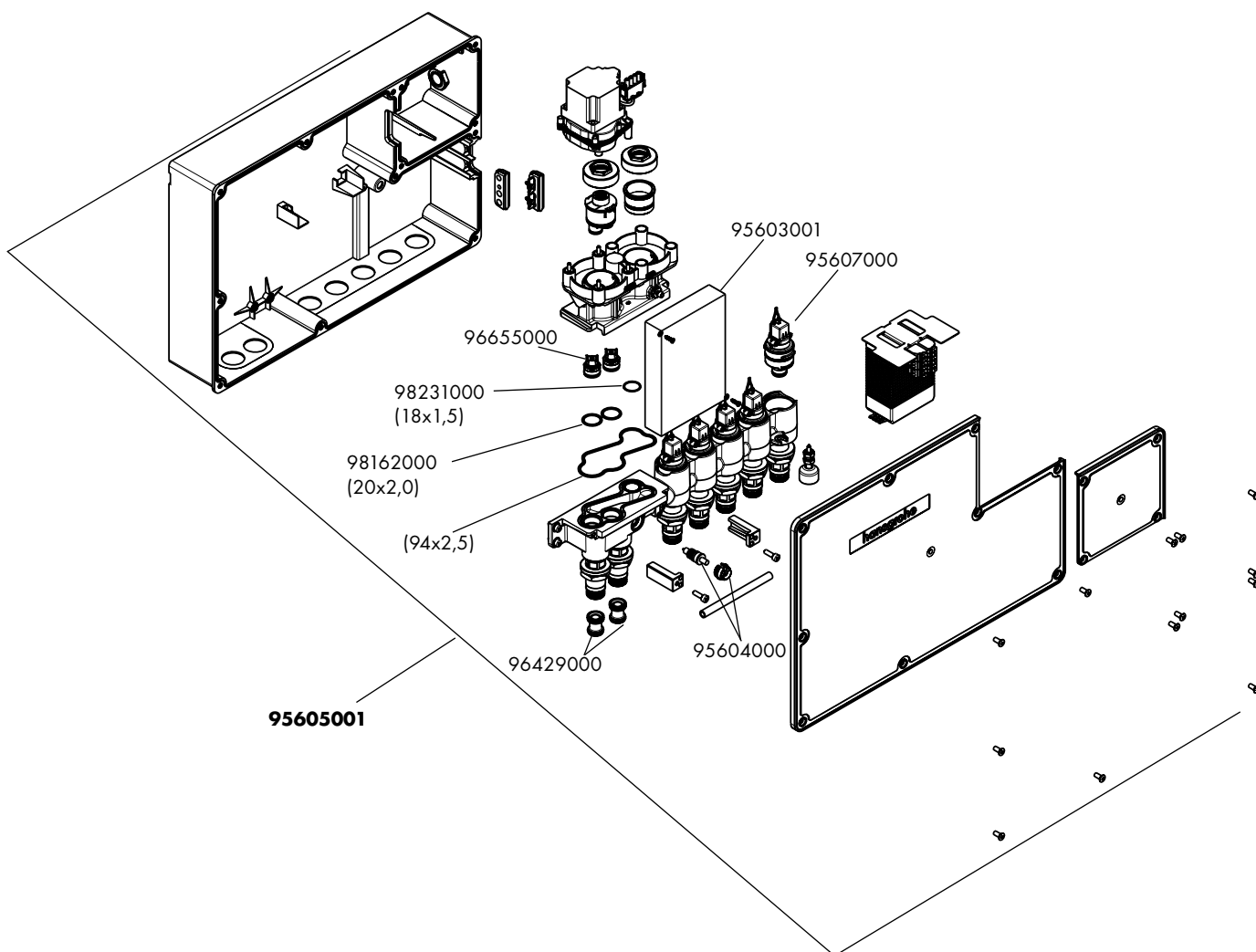
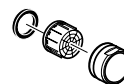



---

## Cleaning Recommendation for Hansgrohe Products

Modern bathroom faucets, kitchen mixers and showers consist of very different materials to comply with the needs of the market with regard to design and functionality. To avoid damage, it is necessary to consider certain criteria when cleaning.

### At the cleaning of the fittings and showers, in principle, it must be pointed out:

- Only use cleaning material which is explicitly intended for this type of application.
- Never use cleaning materials, which contain hydrochloric acid, formic acid, chlorine pale lye or acetic acid, as they cause considerable damage.
- Phosphorus acidic cleaners are only conditionally applicable.
- Do not mix cleaning agents, unless directed by the manufacturer.
- Never use cleaning materials or appliances with an abrasive effect, such as unsuitable cleaning powders, sponge pads or microfiber cloths.
- Always follow the instructions on the cleaning agent package with respect to specified cleaner dosage and contact time.
- The building up of calcifications has to be removed by cleaning regularly.
- When using spray cleaners, spray first onto a soft cloth or sponge never directly onto the product, as drops could enter openings and gaps and cause damage.
- After cleaning, rinse thoroughly with clean water to remove any cleaner residue.
- The use of steam cleaners is not permitted. The high temperatures can damage the products.

### Important

- Residues of liquid soaps, shampoos and shower foams can also cause damage, so rinse with clean water after use.
- The damage of already damaged surfaces will deteriorate under the effect of the cleansers.
- **Components with damaged surfaces must be replaced, otherwise there is a risk of injury.**
- **Damage caused by improper treatment is not covered by our warranty.**

## Conseil de nettoyage pour les produits Hansgrohe

De nos jours le sanitaire moderne, la robinetterie et les douchettes se composent de matériaux très différents pour satisfaire à la demande concernant le design et la fonctionnalité. Pour éviter les détériorations et les réclamations, aussi bien pour l'utilisation que pour le nettoyage prochain, certains critères seront à prendre en considération.

### A prendre en considération lors de l'entretien de la robinetterie et de douchettes:

- On doit seulement utiliser les produits de nettoyage qui sont formellement prévus pour ce domaine.
- Aucun contact avec l'application de nettoyants contenant de l'acide chlorhydrique, de l'acide formique ou de l'acide acétique qui peuvent causer de considérables détériorations.
- Les nettoyants à base d'acide phosphorique, aussi, ne sont pas à utiliser sans réserves.
- Le mélange de nettoyants en général n'est pas autorisé.
- L'utilisation de produits de nettoyage récurants et des ustensiles comme des frottoirs, des éponges à récurer et des torchons microfibrés est exclue.
- Les conseils d'entretien des producteurs de nettoyants sont à suivre obligatoirement.
- Le nettoyage est à faire correspondre avec le dosage, le temps d'action, spécifique à l'objet et à la nécessité.
- Le dépôt de calcaire est évité par un nettoyage régulier.
- Pour le nettoyage avec produit vaporisé liquide, en aucun cas sur la robinetterie, mais au contraire aspergé sur le chiffon (torchon, éponge) et effectuer comme cela le nettoyage, car les aérosols peuvent pénétrer dans les ouvertures et fentes de la robinetterie et peuvent provoquer des détériorations.
- Après le nettoyage rincez avec suffisamment d'eau claire pour éliminer les restes de produits attachés.
- L'utilisation d'appareil de nettoyage à vapeur n'est pas autorisée, car les températures importantes peuvent détériorer les produits.

### Indications importantes

- Les produits pour le corps comme les savons liquides, les shampooings ou les gels de douche peuvent causer des détériorations.
- Ici aussi on doit: Après l'utilisation rincer soigneusement les restes avec de l'eau.

### Conseil de nettoyage

- **Les détériorations imputables à un mauvais entretien ne peuvent être pris en considération par notre garantie.**
- Par l'action d'un nettoyant sur les revêtements déjà endommagés il se produit une aggravation des dégâts.

---

## Recomendación de limpieza para los productos de Hansgrohe

Hoy en día, las griferías de baño y de cocina así como duchas modernas se componen de materiales muy distintos para satisfacer las exigencias del mercado respecto al diseño y la funcionalidad. Para evitar daños y reclamaciones hay que tener en cuenta ciertos aspectos tanto en el uso como en su limpieza.

### Para el cuidado de las griferías y las duchas en principio hay que seguir lo siguiente:

- Usar sólo detergentes previstos específicamente para este campo de aplicación.
- No aplicar detergentes que contengan ácido clorhídrico, fórmico o acético porque pueden causar daños importantes.
- Detergentes que contienen ácido fosfórico tampoco pueden ser aplicados ilimitadamente. Por regla general no se deben mezclar detergentes.
- Tampoco se deben utilizar utensilios abrasivos, como son polvos abrasivos, esponjas o paños de microfibra.
- Se tienen que seguir siempre las sugerencias de empleo de los fabricantes de los detergentes.
- La limpieza tiene que ser realizada según la dosificación y el tiempo de actuación, en función del objeto y ajustada a las necesidades específicas del mismo.
- Gracias a una limpieza periódica se pueden evitar los depósitos de cal.
- No conviene rociar el detergente en ningún caso sobre la grifería sino sobre los textiles y ejecutar la limpieza así, porque el líquido puede entrar en aperturas o hendiduras de la grifería y causar daños.
- Después de la limpieza hay que aclarar con suficiente agua para eliminar completamente el resto de detergente.
- La utilización de limpiadores a vapor no está permitida, las altas temperaturas pueden dañar los productos.

### Indicaciones importantes

- Los residuos de productos de aseo como jabón líquido, champús y gel de ducha pueden dañar también los materiales.
- Por lo que también se deberá prestar atención a lo siguiente: aclarar con abundante agua después del uso.
- Con materiales ya dañados la acción de detergentes incrementará el desgaste de estos.
- **Los componentes con superficies dañadas deberán cambiarse, en otro caso se corre el peligro de lesionarse.**
- Los daños que resulten de un uso inadecuado no están incluidos en nuestra garantía.

---

## Limited Consumer Warranty

This product has been manufactured and tested to the highest quality standards by Hansgrohe, Inc. ("Hansgrohe").

This warranty is limited to Hansgrohe products that are purchased by a consumer in the United States or Canada after March 1, 1996, and installed in either in the United States or in Canada.

### WHO IS COVERED BY THE WARRANTY

This warranty extends to the original purchaser only. This warranty is non-transferable.

### WHAT IS COVERED BY THE WARRANTY

The warranty covers only your Hansgrohe manufactured product. Hansgrohe warrants this product against defects in material or workmanship as follows:

Hansgrohe will replace at no charge for parts only or, at its option, replace any product or part of the product that proves defective because of improper workmanship and/or material, under normal installation, use, service and maintenance. If Hansgrohe is unable to provide a replacement and repair is not practical or cannot be made in timely fashion, Hansgrohe may elect to refund the purchase price in exchange for the return of the product.

### LENGTH OF WARRANTY

Replacement or repaired parts of products will be covered for the term of this warranty, as stated in the following two sentences. If you are a consumer who purchased the product for use primarily for personal, family or household purposes, this warranty extends for as long as you own the product and the home in which the product is originally installed. If you purchased the product for use primarily for any other purpose, including, without limitation, a commercial purpose, this warranty extends only (i) for 1 year, with respect to Hansgrohe & Commercial products, and (ii) for 5 years, with respect to Axor products.

### THIS WARRANTY DOES NOT COVER, AND HANSGROHE WILL NOT PAY FOR:

- A. Conditions, malfunctions or damage not resulting from defects in material or workmanship.
- B. Conditions, malfunctions or damage resulting from (1) normal wear and tear, improper installation, improper maintenance, misuse, abuse, negligence, accident or alteration; (2) the use of abrasive or caustic cleaning agents or "no-rinse" cleaning products, or the use of the product in any manner contrary to the product instructions; or (3) conditions in the home such as excessive water pressure or corrosion.
- C. Labor and other expenses for disconnection, deinstallation, or return of the product for warranty service (including but not limited to proper packaging and shipping costs), or for installation or reinstallation of the product.
- D. Accessories, connected materials and products, or related products not manufactured by Hansgrohe.
- E. Any Hansgrohe or Axor product sold for display purposes.
- F. Rubbed Bronze finish is subject to a 3-year limited warranty. Chrome and all PVD finishes are covered by the limited lifetime warranty.
- G. Hansgrohe Water Filtration System is subject to a 1-year limited warranty. Warranty does not include replacement filters.

### TO OBTAIN WARRANTY PARTS OR INFORMATION

Contact your Hansgrohe retailer, or contact Technical Service at:

Hansgrohe, Inc.  
1492 Bluegrass Lakes Parkway  
Alpharetta, GA 30004  
Toll-free 800-334-0455

In requesting warranty service, you will need to provide:

1. The sales receipt or other evidence of the date and place of purchase.
2. A description of the problem.
3. Delivery of the product or the defective part, postage prepaid and carefully packed and insured, to:

Hansgrohe, Inc.  
1492 Bluegrass Lakes Parkway  
Alpharetta, GA 30004  
Toll-free 800-334-0455

When warranty service is completed, any repaired or replacement product or part will be returned to you postage prepaid.

## EXCLUSIONS AND LIMITATIONS

**REPAIR OR REPLACEMENT (OR, IN LIMITED CIRCUMSTANCES, REFUND OF THE PURCHASE PRICE) AS PROVIDED UNDER THIS WARRANTY IS THE EXCLUSIVE REMEDY OF THE PURCHASER. HANSGROHE NEITHER ASSUMES NOR AUTHORIZES ANY PERSON TO CREATE FOR IT ANY OTHER OBLIGATION OR LIABILITY IN CONNECTION WITH THIS PRODUCT. HANSGROHE SHALL NOT BE LIABLE TO PURCHASER OR ANY OTHER PERSON FOR ANY INCIDENTAL, SPECIAL OR CONSEQUENTIAL DAMAGES, ARISING OUT OF BREACH OF THIS WARRANTY OR ANY IMPLIED WARRANTY (INCLUDING BUT NOT LIMITED TO ANY IMPLIED WARRANTY OF MERCHANTABILITY).**

Some States do not allow the exclusion or limitation of incidental or consequential damages, so the above limitation or exclusion may not apply to you. This warranty gives you specific legal rights, and you may also have other rights that vary from state to state.

**TO THE EXTENT PERMITTED BY LAW, ANY IMPLIED WARRANTIES OF MERCHANTABILITY AND FITNESS FOR A PARTICULAR PURPOSE, ARE LIMITED TO THE DURATION OF THE EXPRESS WARRANTY.**

Some states do not allow limitations on how long an implied warranty may last, so the above limitations may not apply to you. You may be required by law to give us a reasonable opportunity to correct or cure any failure to comply before you can bring any action in court against us under the Magnuson-Moss Warranty Act.

### PRODUCT INSTRUCTIONS AND QUESTIONS

Upon purchase or prior to installation, please carefully inspect your Hansgrohe product for any damage or visible defect. Prior to installing, always carefully study the enclosed instructions on the proper installation and the care and maintenance of this product. If you have questions at any time about the use, installation or performance of your Hansgrohe product, or this warranty, please write us or call us toll-free at 800-334-0455.



Hansgrohe, Inc. • 1490 Bluegrass Lakes Parkway • Alpharetta, GA 30004  
Tel. 770-360-9880 • Fax 770-360-9887

[www.hansgrohe-usa.com](http://www.hansgrohe-usa.com)