

**Versostat<sup>2</sup>**  
15348000

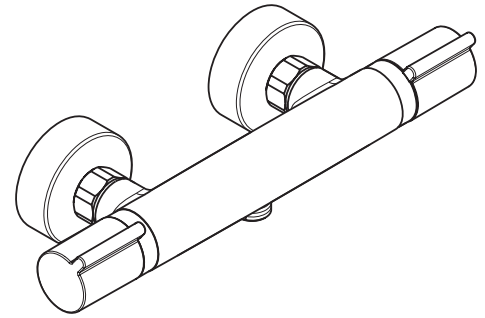

**Versostat<sup>2</sup>**  
15368000



## Safety Notes

- ⚠️ Gloves should be worn during installation to prevent crushing and cutting injuries.
- ⚠️ The product may only be used for bathing, hygienic and body cleaning purposes.
- ⚠️ Children as well as adults with physical, mental and/or sensoric impairments must not use this product without proper supervision. Persons under the influence of alcohol or drugs are prohibited from using this product.
- ⚠️ The hot and cold supplies must be of equal pressures.

## Installation Instructions

- Prior to installation, inspect the product for transport damages. After it has been installed, no transport or surface damage will be honoured.
- The pipes and the fixture must be installed, flushed and tested as per the applicable standards.
- The plumbing codes applicable in the respective countries must be observed.
- The product is not designed to be used with steam baths!
- If the continuous water heater causes any problems, or you have different water pressures you must install a water limiter to the cold supply, (ordered separately, article number 97510000).

## Technical Data

Operating pressure:	max. 1 MPa
Recommended operating pressure:	0,1 - 0,5 MPa
Test pressure:	1,6 MPa (1 MPa = 10 bar = 145 PSI)
Hot water temperature:	max. 60 °C
Centre distance:	150±12 mm
Connections G 1/2:	cold right - hot left
Thermal disinfection:	70 °C / 4 min

- Safety against backflow
- The product is exclusively designed for drinking water!

## Symbol description

 Do not use silicone containing acetic acid!

 max. ≈42 °C **Safety Function** (see page 7)

The desired maximum temperature for example max. 42 °C can be pre-set thanks to the safety function.

 **Adjustment** (see page 7)

After the installation, the output temperature of the thermostat must be checked. A correction is necessary if the temperature measured at the output differs from the temperature set on the thermostat.

 **Maintenance** (see page 9)

- The check valves must be checked regularly according to EN 806-5 in accordance with national or regional regulations (at least once a year).
- To guarantee the smooth running of the thermostat, it is necessary from time to time to turn the thermostat from total hot to total cold.

 **Dimensions** (see page 10)

 **Flow diagram** (see page 10)

- ① Shower outlet
- ② Tub outlet

 **Spare parts** (see page 11)

 **Cleaning** (see page 9)

 **Operation** (see page 8)

Fault	Cause	Remedy
Insufficient water	- Supply pressure inadequate	- Check water pressure (If a pump has been installed check to see if the pump is working).
	- Regulator filter dirty	- Clean filter in front of the mixer and on the MTC-thermo cartridge
	- Shower filter seal dirty	- Clean filter seal between shower and hose
Crossflow, hot water being forced into cold water pipe, or vice versa, when mixer is closed	- Backflow preventers dirty or leaking	- Clean backflow preventers, exchange if necessary
Spout temperature does not correspond with temperature set	- Thermostat has not been adjusted	- Adjust thermostat
	- Hot water temperature too low	- Increase hot water temperature to 42 °C to 60 °C
Temperature regulation not possible	- thermo cartridge calcified	- Exchange thermo cartridge
	- Hot and cold supplies are reversed	- Control unit for reversed connections #92373000
Instantaneous heater didn't work with thermostat	- Filters are dirty	- Clean the filter / exchange filter
	- check valve hasn't moved back	- Exchange check valves
	- Flow limiter in handshower isn't removed	- Remove flow limiter
	- Shower filter seal dirty	- Clean filter seal between shower and hose
Shower or spout dripping	- Dirt or sedimentation on valve seat, shut-off unit damaged	- Clean or exchange shut-off unit



**On the following pages 3 - 5 you can find important information only for the installation in UK**

### Safety and Important Information

Hansgrohe products are safe provided they are installed, used and maintained in accordance with these instructions and recommendations. Please read these instructions thoroughly and retain for future use. The plumbing installation of this thermostat mixing valve must comply with the requirements of UK. Water Regulations/Bylaws (Scotland), Building Regulations or any other regulations specified by the local Water Authority and supplier. The installation of thermostatic mixing valves must comply with the requirements of the Water Supply (Water Fittings) Regulations 1999. We strongly recommend that you use a plumber registered with or a member of an Association:

- Chartered Institute of Plumbing and Heating Engineering (CIPHE)
- Water Industry Approved Plumber Scheme (WIAPS)

Dispose of plastic bags carefully. Keep children well away from the work area. Check for hidden pipes and cables in the wall before drilling holes. The unit must be mounted on a finished waterproofed wall surface (usually tiles). If you are using power tools (e.g. to drill holes) wear safety glasses and always disconnect tools from the power supply after use. Do not operate the shower unit if the hand shower or spray hose has been damaged or is blocked. Do not block the flow of water from the hand shower, by placing it on your hand or any other part of your body or foreign object. The thermostatic unit should be serviced annually by a qualified person to ensure maximum safety during use. The thermostatic mixing valve will be installed in such a position that maintenance of the TMV and its valves and the commissioning and testing of the TMV can be undertaken. The mixer is fitted with check valves (page 11 pos. 96737000 and 93136000). There are filters on the thermostatic element too (page 11 pos. 96922000 and 98282000). The fitting of isolation valves is required (preferred location page 4 Installation Requirements).

### Technical Hotline

Tel: 01926242300  
Email: support@hansgrohe.co.uk

### Technical Data

This thermostatic valve may be appropriate for the following conditions and installations. Verify, see procedure 1.a)

HIGH PRESSURE (HP-S / HP-T)

Type 3 High Pressure shower HPS only

Type 2 High Pressure shower or tub as appropriate HP-S and or HP-T

Operating pressure:	max. 10 bar
Recommended operating pressure:	1 - 5 bar
Test pressure:	16 bar
Hot water temperature:	max. 60 °C
Recommended hot water temp.:	55 - 60 °C
Rate of flow from bath spout:	20 l/min. @ 3 bar
Rate of flow from shower outlet:	18 l/min. @ 3 bar
Maximum outlet temperature:	43 °C +/-*
Safety check:	40 °C
Hot water connection:	Left hand
Cold water connection:	Right hand

### Mixed water temperature

Application	Mixed water temperature (at point of discharge).
Shower	41 °C max.
Washbasin	41 °C max.
Bath (44 °C fill)	44 °C max.
Minimum difference between hot water and mixed water temperature:	6 K

Hot and cold supply pressure should be balanced

\* For preset outlet temperature adjustment – See page 7.

**NB.** If a water supply is fed by gravity then the supply pressure should be verified to ensure the conditions of use are appropriate for the valve.

### Recommended outlet temperatures

The TMV scheme recommends the following set maximum mixed water outlet temperatures for use in all premises:

44 °C for bath fill but see notes below;

41 °C for showers;

41 °C for washbasins.

The maximum mixed water temperature can be 2 °C above the recommended maximum set outlet temperatures.

**Note:** 46 °C is the maximum mixed water temperature from the bath tap. The maximum temperature takes account of the allowable temperature tolerances inherent in thermostatic mixing valves and temperature losses in metal baths.

It is not a safe bathing temperature for adults or children.

The British Burns Association recommends 37 to 37.5 °C as a comfortable bathing temperature for children. In premises covered by the Care Standards Act 2000, the maximum mixed water outlet temperature is 43 °C.

### Installation Requirements

This thermostatic mixer valve must be installed in compliance with current Water Regulations. If you have any doubts about the Water Regulation requirements contact your local water services provider or use the services of a professional plumber.

This mixer valve is suitable for use with the following water supply systems:

Gas Combination Boiler (multi-point) 1.0 - 10 bar\*

Unvented System (pressure balanced) 1.0 - 10 bar

Pumped System 1.0 - 10 bar

**IMPORTANT:** If you install this mixer with a gravity fed system, there must be a minimum head (vertical distance) from the underside of the cold water storage tank to the showerhead position of at least 5 metre.

Before connecting the mixer, water should be flushed through the system to remove all debris that might otherwise damage the valve.

\* If pressure is in excess of 3.5 bar, a pressure-reducing valve should be fitted.

### Supply Conditions TMV Type 2

#### Operating pressure range High pressure

Maximum static pressure - bar	10
Flow pressure, hot and cold - bar	0.5 to 5
Hot supply temperature - °C	55 to 65
Cold supply temperature - °C	5 to 25

### Supply Conditions TMV Type 3

#### Operating pressure range High pressure

Maximum static pressure - bar	10
Flow pressure, hot and cold - bar	1 to 5
Hot supply temperature - °C	55 to 65
Cold supply temperature - °C	5 to 20

Valves operating outside these conditions cannot be guaranteed to operate as Type 2 or Type 3 valves.

### Commissioning and in-service tests

#### Commissioning

##### Purpose

Since the installed supply conditions are likely to be different from those applied in the laboratory tests it is appropriate, at commissioning, to carry out some simple checks and tests on each mixing valve to provide a performance reference point for future in-service tests.

##### Procedure

- Check that:
  - the thermostatic mixing valve and its designation match the intended installation and application, see <https://www.kiwa.com/gb/en/services2/testing/tmv-testing/> <https://www.kiwa.com/gb/en/about-kiwa/tmvs-certificate-search/>
  - the supply pressures are within the range of operating pressures for the designation of the valve
  - the supply temperatures are within the range permitted for the valve and by guidance information on the prevention of legionella etc.
- Adjust the temperature of the mixed water in accordance with the manufacturer's instructions (page 7) and the requirement of the application and then carry out the following sequence:
  - record the temperature of the hot and cold water supplies
  - record the temperature of the mixed water at the largest draw-off flow rate

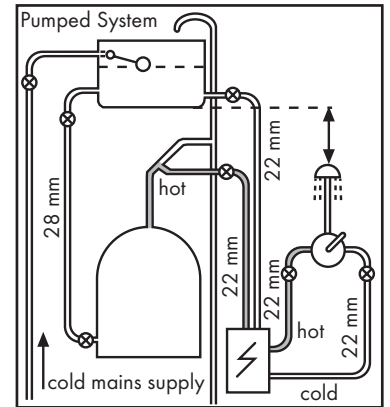
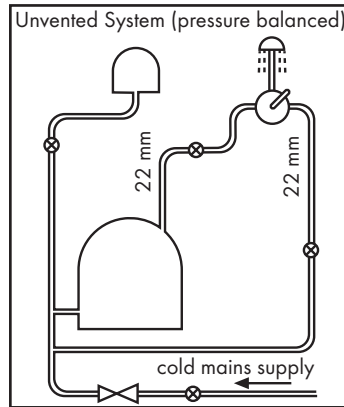
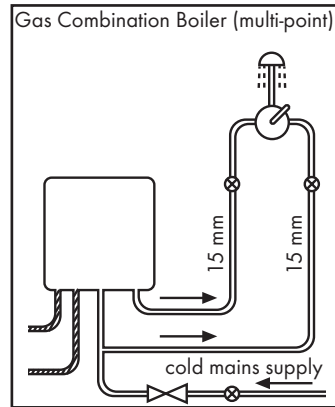
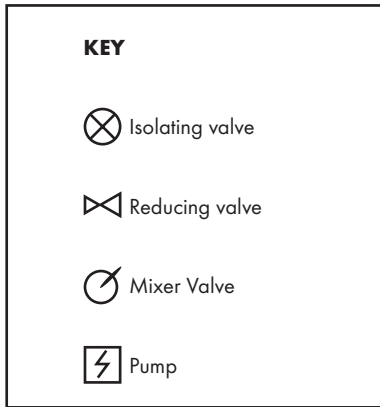

- c) record the temperature of the mixed water at a smaller draw-off flow rate, which shall be measured
- 3.** Perform the cold water isolation test:
- a) operate the TMV and achieve a normal flowrate for the application and record the initial mixed outlet temperature
  - b) isolate the cold-water supply to the valve
  - c) collect the water discharged from the TMV outlet for 5 seconds into a suitably graduated measuring vessel
  - d) continue to collect the water discharged from the TMV outlet in a second vessel for a further period of 30 seconds or 60 seconds for Type 3 installations
  - e) re-open (restore) the cold-water supply and after 30 seconds measure the mixed water temperature
  - f) record the maximum temperature achieved as a result and the final stabilised temperature
- NOTE:** The final stabilised mixed water temperature should not exceed the values in Table A.
- 4.** Record the equipment, thermometer etc. used for the measurements See acceptance criteria on page 4

Table A: Guide to maximum stabilised temperatures recorded during site tests

Application	Max. mixed water temperature
Shower	43 °C
Washbasin	43 °C
Bath (44 °C fill)	46 °C

The mixed water temperature at terminal fitting should never exceed 46°C. If there is a residual flow during the commissioning or the annual verification (cold water supply isolation test), then this is acceptable providing the temperature of the water seeping from the valve is no more than 2 °C above the designated maximum mixed water outlet temperature setting of the valve. Temperature readings should be taken at the normal flow rate after allowing for the system to stabilise. The sensing part of the thermometer probe must be fully submerged in the water that is to be tested. Any TMV that has been adjusted or serviced must be re-commissioned and re-tested in accordance with the manufacturers' instructions.

**In-service testing**

**Purpose**

The purpose of in-service testing is to regularly monitor and record the performance of the thermostatic mixing valve. Deterioration in performance can indicate the need for service work on the valve and/ or the water supplies.

**Procedure**

- 1.** Carry out the commissioning procedure **1.** (a) to (c), the procedure **2.** (a) to (c) and the procedure **3.** (a) to (f) on page 3 using the same measuring equipment, or equipment to the same specifications.
- 2.** If the mixed water temperature has changed significantly from the previous test results (e.g. > 1 K), record the change and before re-adjusting the mixed water temperature check:
  - a) that any in-line or integral strainers are clean
  - b) any in-line or integral check valves or other anti-backsiphonage devices are in good working order
  - c) any isolating valves are fully open
- 3.** With an acceptable mixed water temperature, complete the commissioning procedure **3.** (a) to (e) on page 4.
- 4.** If at step **3.** (e) on page 4 the final mixed water temperature is greater than the values in Table A and / or the maximum temperature exceeds the correspond-

ing value from the previous test results by more than about 2 K, the need for service work is indicated.

**NOTE:** In-service testing should be carried out with a frequency which identifies a need for service work before an unsafe water temperature can result. In the absence of any other instruction or guidance, the procedure described in „Frequency of in-service testing“ may be used.

**Acceptance criteria for TMV Type 2 Tub/Bath:**

- 1.** The volume collected in the first period of 5 s shall not exceed 400 ml.
- 2.** The volume collected in the second period of 30 s shall not exceed an additional 500 ml.
- 3.** After restoration of the cold-water supply (30 s) the mixed water outlet temperature shall not differ by more than 2 °C from the initial set mixed water temperature.

**Acceptance criteria for all other TMV Type 2 outlets:**

- 1.** The volume collected in the first period of 5 s shall not exceed 200 ml.
- 2.** The volume collected in the second period of 30 s shall not exceed an additional 300 ml.
- 3.** After restoration of the cold-water supply (30 s) the mixed water outlet temperature shall not differ by more than 2 °C from the initial set mixed water temperature.

**Acceptance criteria for TMV Type 3 valve:**

- 1.** If there is a flow stream after 5 s then collect any water discharging for 60 seconds. If the volume of water collected is greater than 120ml then further investigation is needed.
- 2.** If there is no flow or if the volume of water collected is less than or equal to 120ml, then restore the cold-water supply, after 15 seconds record the mixed water temperature.
- 3.** After restoration of the cold-water supply (30 s) the mixed water outlet temperature shall not differ by more than 2 °C from the initial set mixed water temperature.

**Frequency of in-service testing TMV Type 3\***

**General**

In the absence of any other instruction or guidance on the means of determining the appropriate frequency of in-service testing, the following procedure may be used:

- 1.** 6 to 8 weeks after commissioning carry out the tests given in **2.** on page 3.
- 2.** 12 to 15 weeks after commissioning carry out the tests given in **2.** on page 3.
- 3.** Depending on the results of **1.** and **4.** several possibilities exist:
  - a) If no significant changes (e.g. < 1 K) in mixed water temperatures are recorded between commissioning and **1.**, or between commissioning and **4.** the next in-service test can be deferred to 24 to 28 weeks after commissioning.
  - b) If small changes (e.g. 1 to 2 K) in mixed water temperatures are recorded in only one of these periods, necessitating adjustment of the mixed water temperature, then the next in-service test can be deferred to 24 to 28 weeks after commissioning.
  - c) If small changes (e.g. 1 to 2 K) in mixed water temperatures are recorded in both of these periods, necessitating adjustment of the mixed water temperature, then the next in-service test should be carried out at 18 to 21 weeks after commissioning.
  - d) If significant changes (e.g. > 2 K) in mixed water temperatures are recorded in either of these periods, necessitating service work, then the next in-service test should be carried out at 18 to 21 weeks after commissioning.
- 4.** The general principle to be observed after the first 2 or 3 in-service tests is that the intervals of future tests should be set to those which previous tests have shown can be achieved with no more than a small change in mixed water temperature.

**\*TMV Type 2: The frequency of performing the in-service tests is 1 year maximum.**

### **Thermostatic Adjustment**

#### **Temperature Limitation**

The temperature is limited by the safety stop to 40°C. If a higher temperature is required, it is possible to over ride the safety stop by depressing the safety button.

**NB.** It is recommended that for private domestic use the maximum mixed water temperature be set at the following factory set values:

Shower Mixer 43°C

Bath/Shower 43°C

For healthcare applications the Temperatures must be set by following the procedures on page 7. This ensures that after correct installation the outlet temperature of the water can never exceed 43°C.

Temperatures can be set by following the procedures on page 7. This ensures that after correct installation the outlet temperature of the water can never exceed 43°C.

To guarantee a smooth running of the thermostatic element, it is necessary from time to time to turn the thermostat from total hot to total cold. The thermostatic mixer valve should be checked annually by a qualified person to ensure correct operation. Whilst this is a recommendation in user / owner domestic dwellings, a duty of care obligation should be considered in commercial bathroom or subletting situations.

The mixer is fitted with check valves (page 11 pos. 96737000 and 93136000) and filters (page 11 pos. 96922000 and 98282000). If the water flow drops the filters need to be cleaned. For that purpose please follow the steps 1 - 5 on page 9.

#### **Calibrating Thermostat**

If the temperature reading is different to the showering temperature, follow the steps 1 - 4 on page 7.

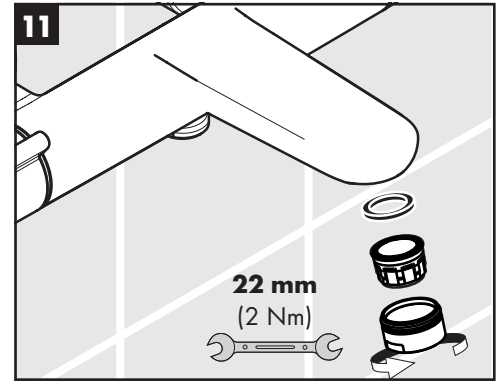
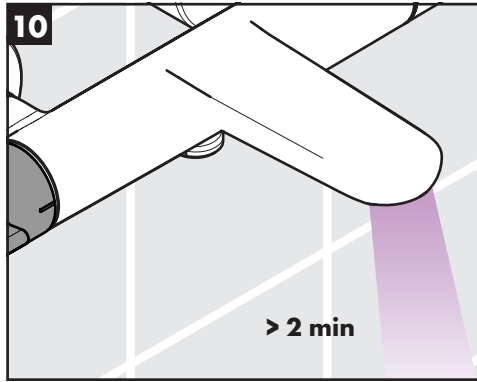
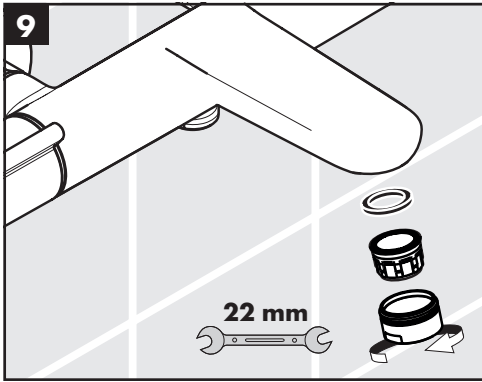
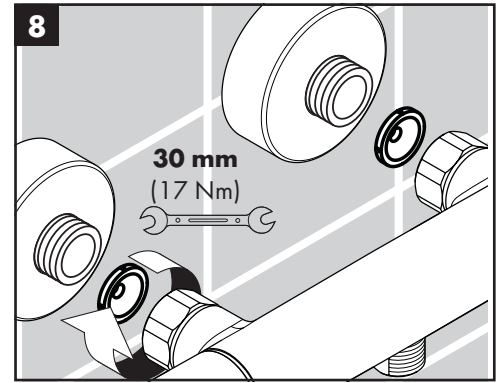
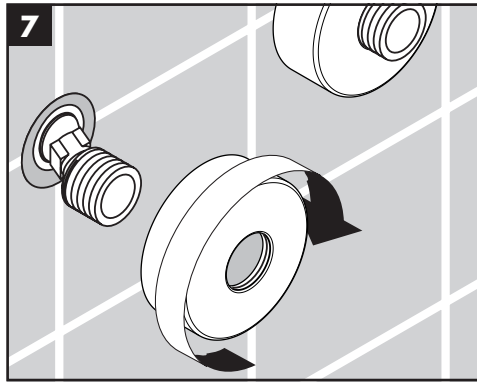
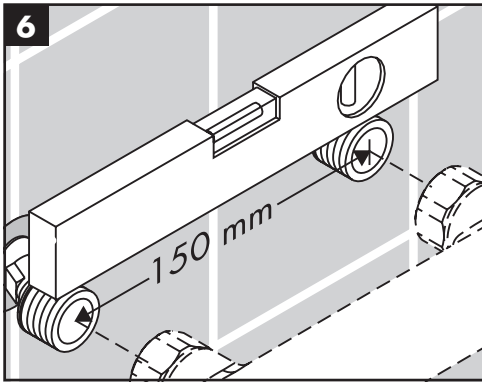
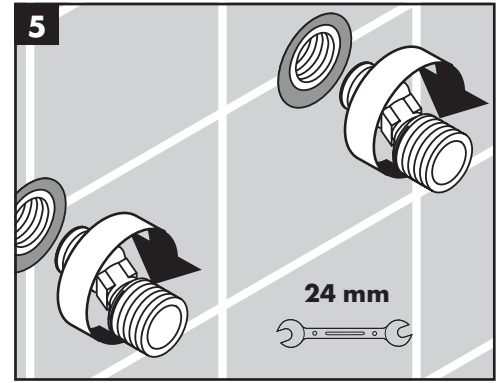
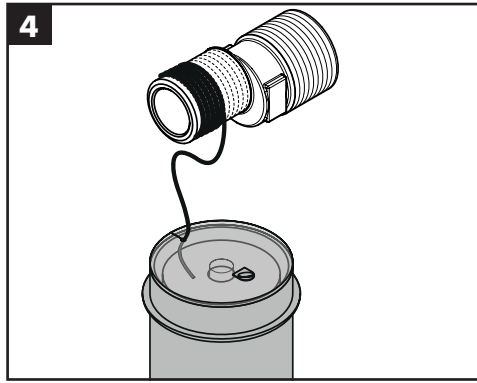
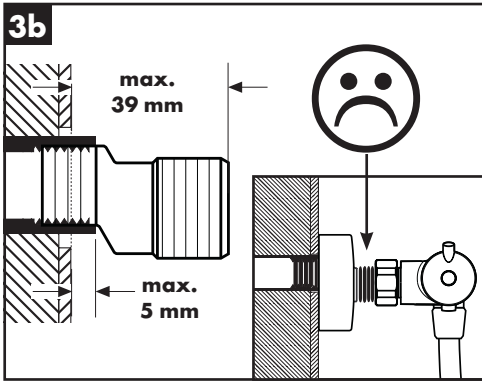
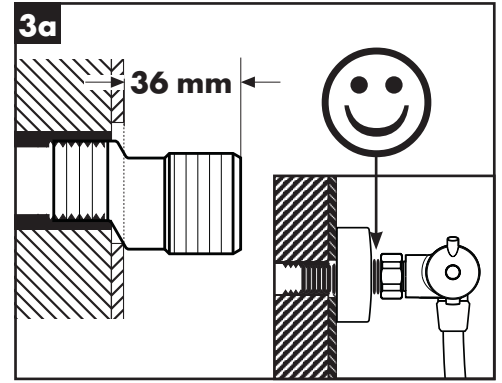
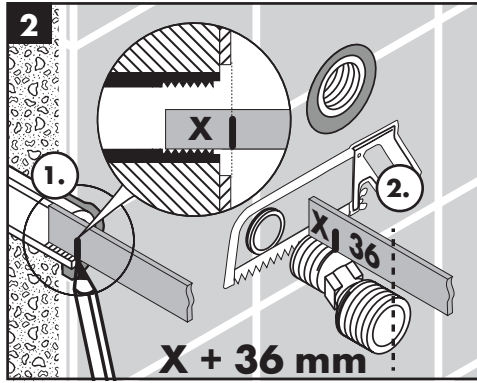
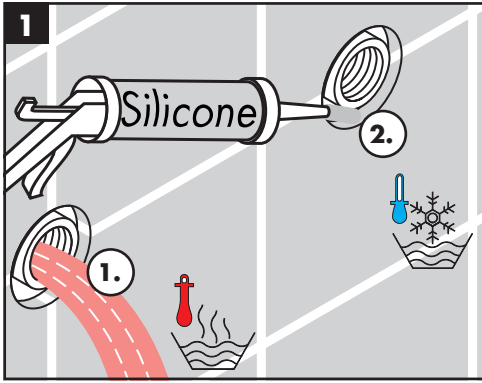

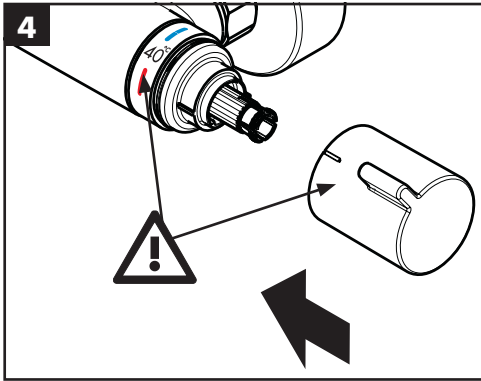
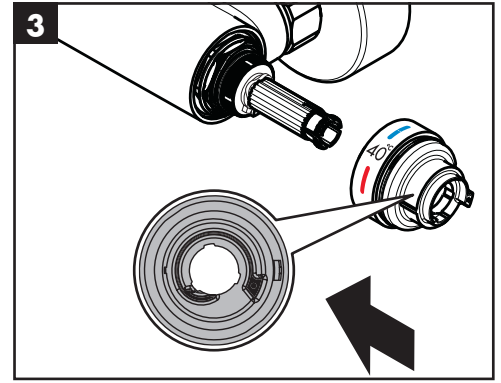
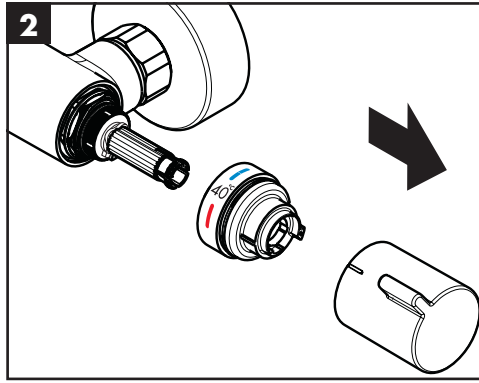
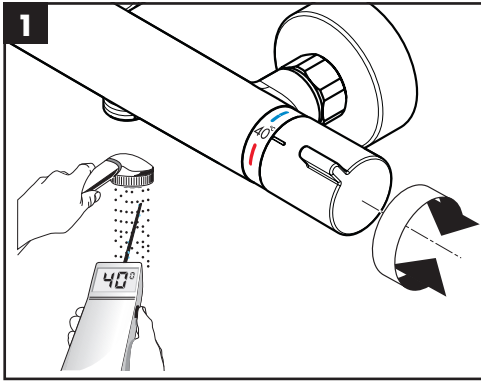

max.  
≈42°C

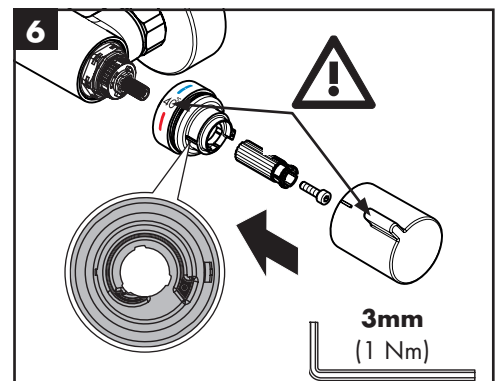
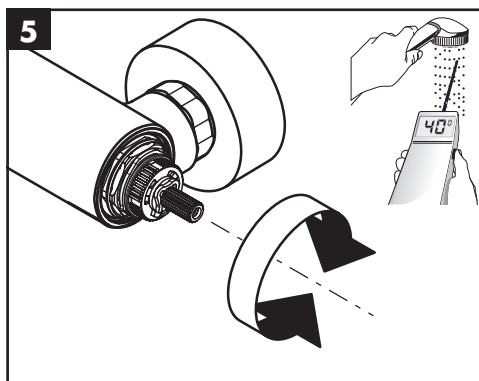
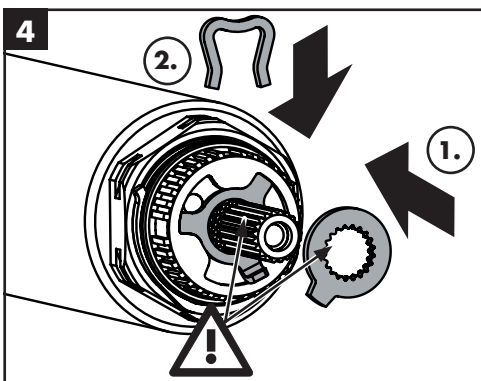
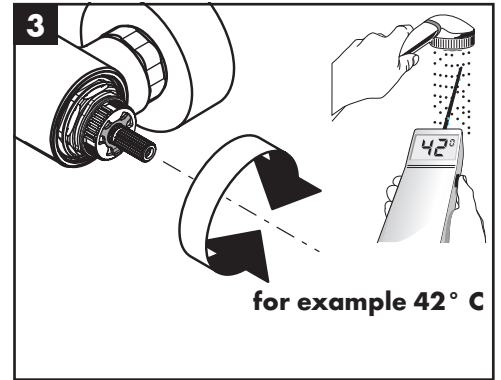
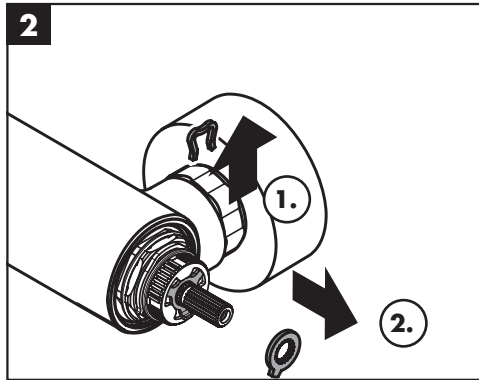
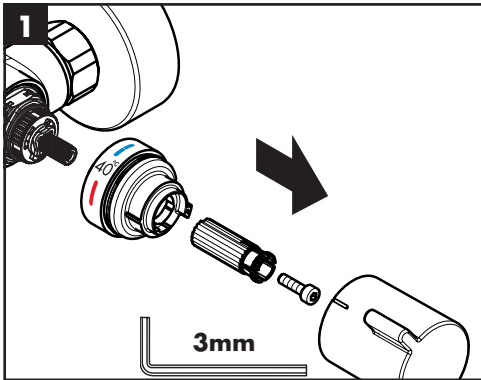

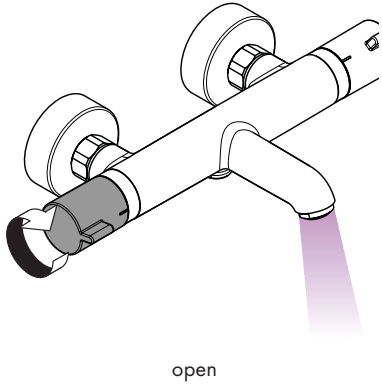

open

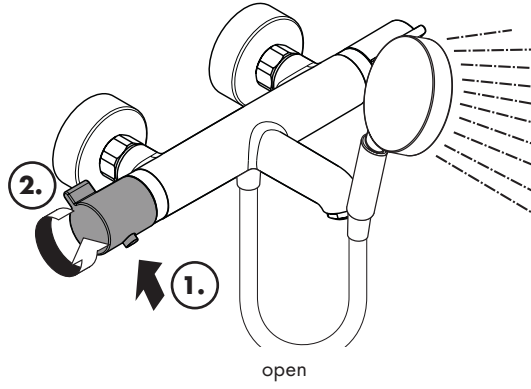

open

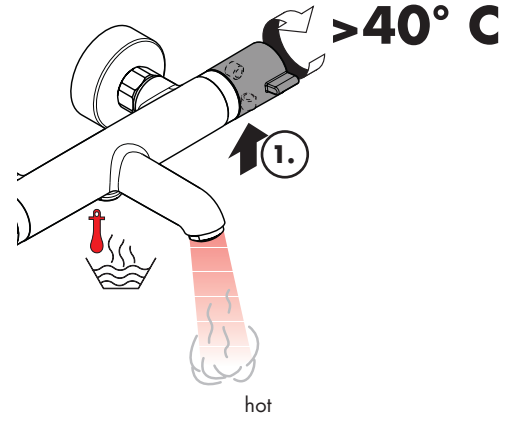

hot

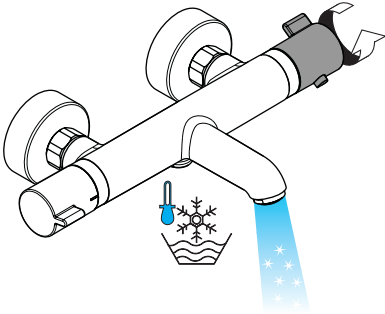

cold

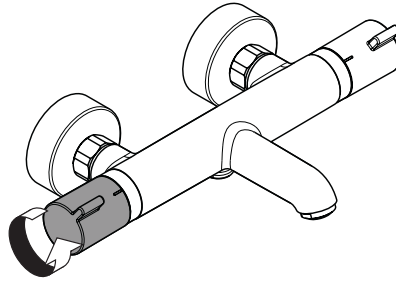

close

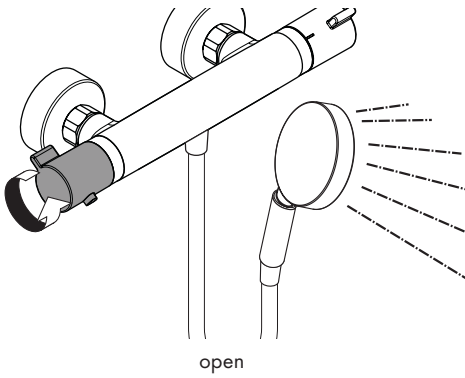

open

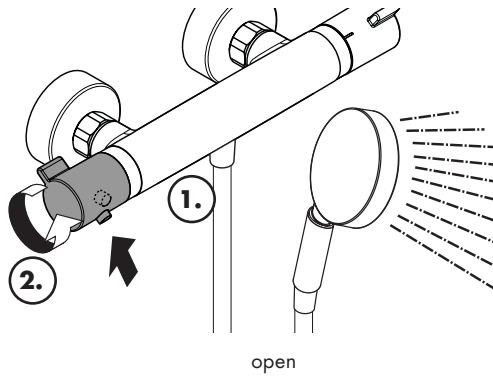

open

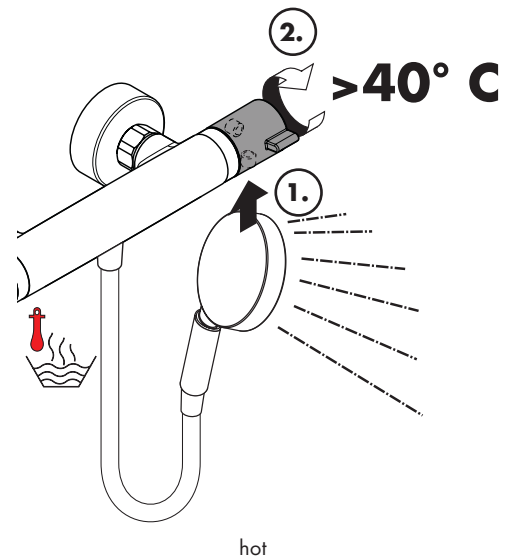

hot

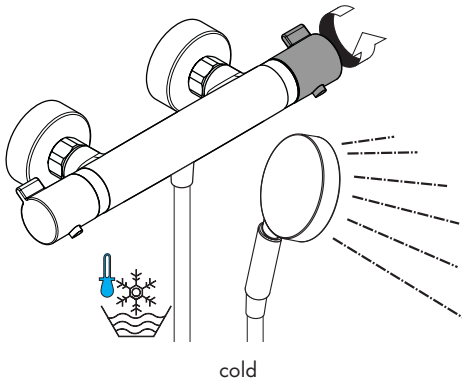

cold

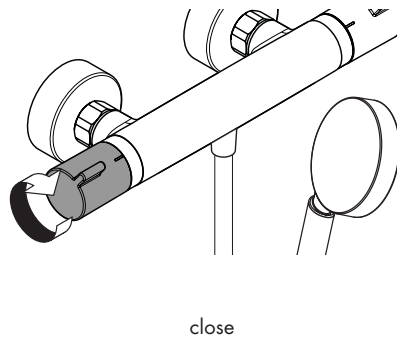

close



[www.hansgrohe.com/cleaning-recommendation](http://www.hansgrohe.com/cleaning-recommendation)

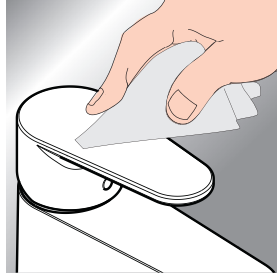

\*[www.hansgrohe.com/warranty](http://www.hansgrohe.com/warranty)



**EN** Cleaning recommendation / Warranty / Contact

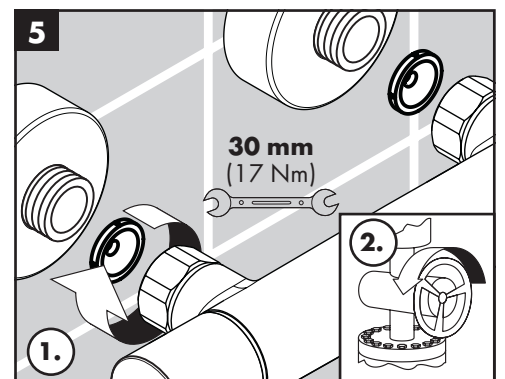
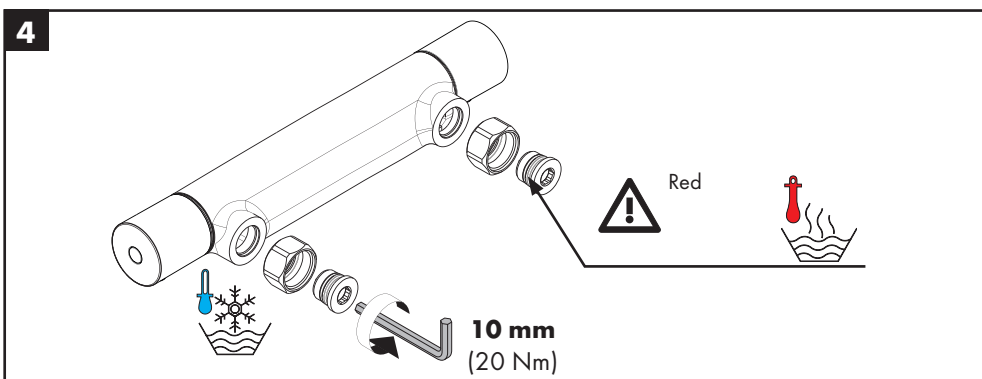
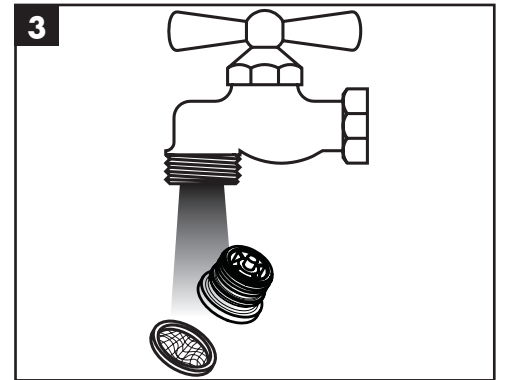
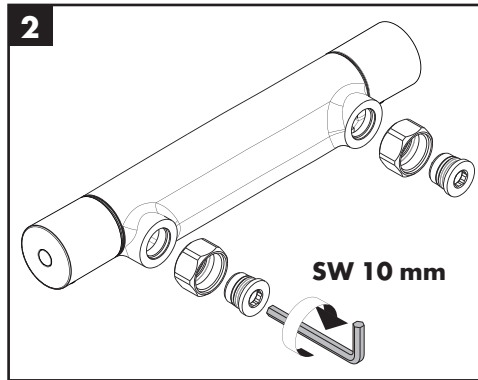
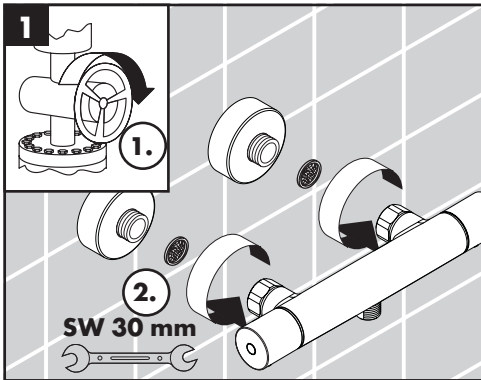



**Versostat<sup>2</sup>**  
15348000

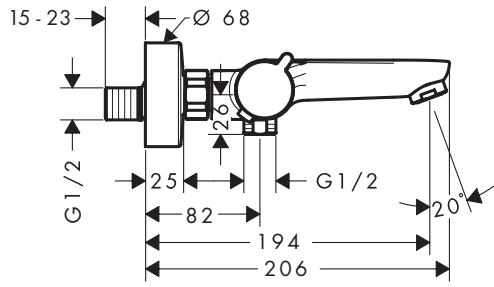

**Versostat<sup>2</sup>**  
15368000

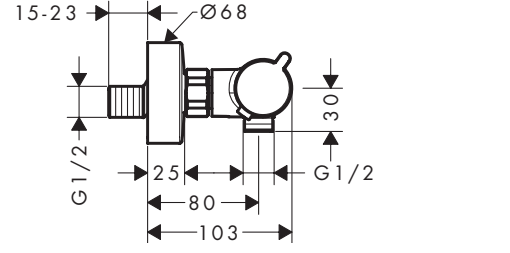

**Versostat<sup>2</sup>**  
15348000

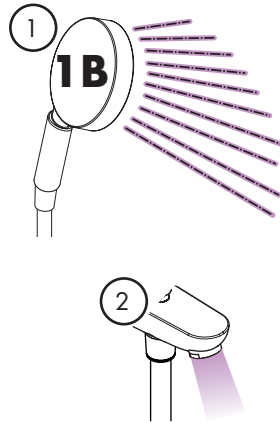
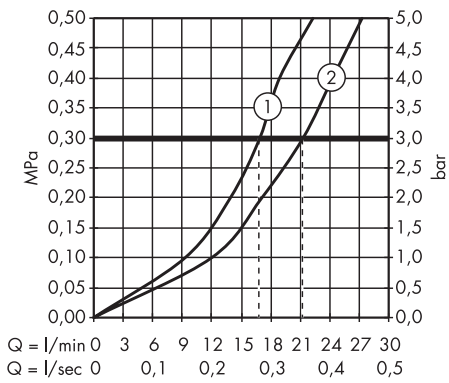

**Versostat<sup>2</sup>**  
15368000

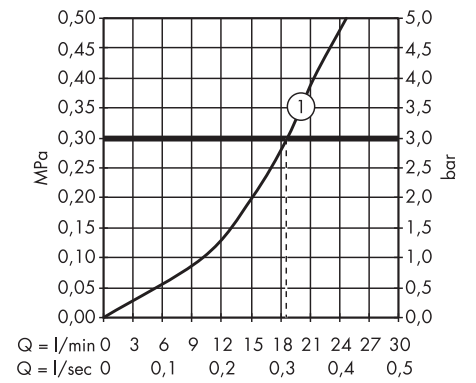

### Versostat<sup>2</sup> 15348000

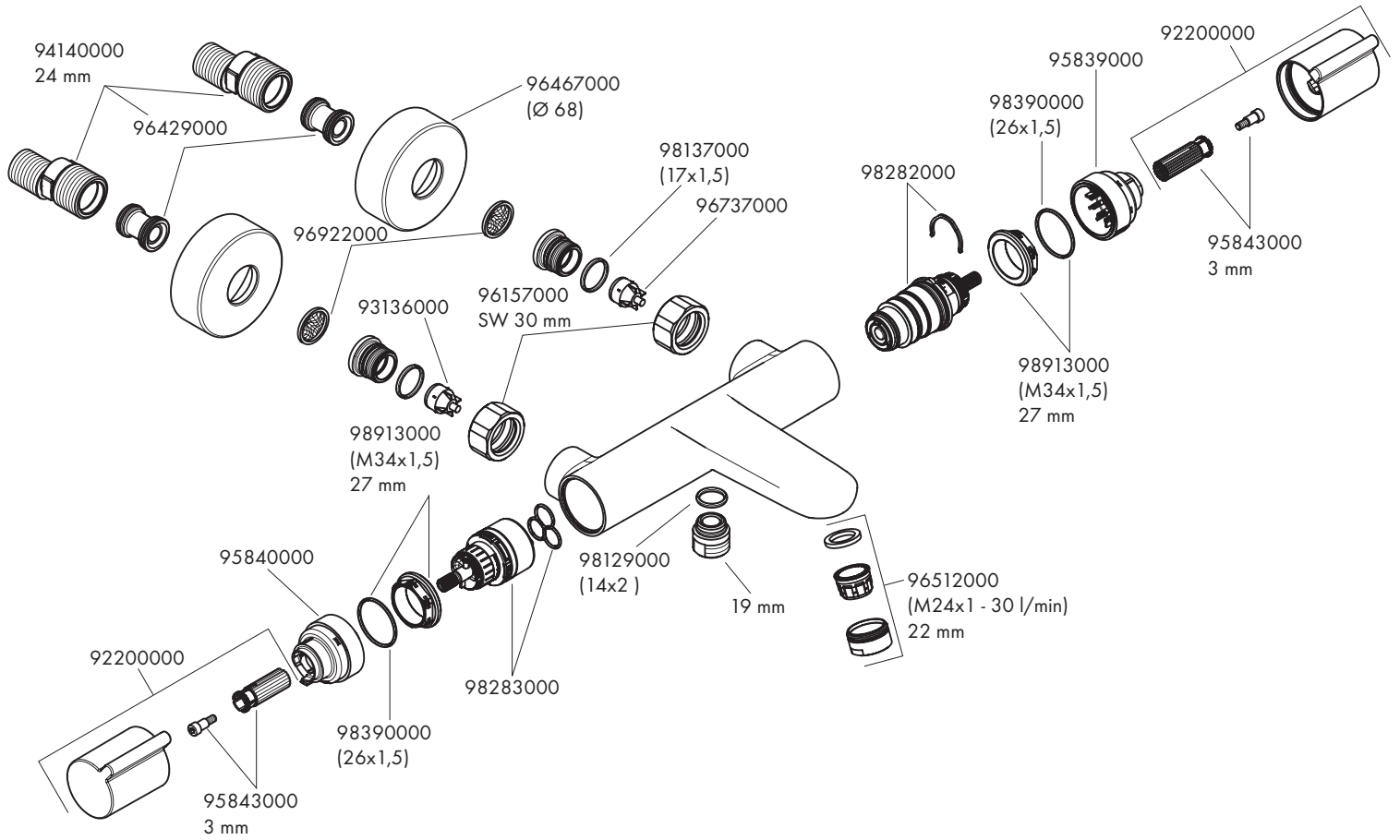

### Versostat<sup>2</sup> 15368000

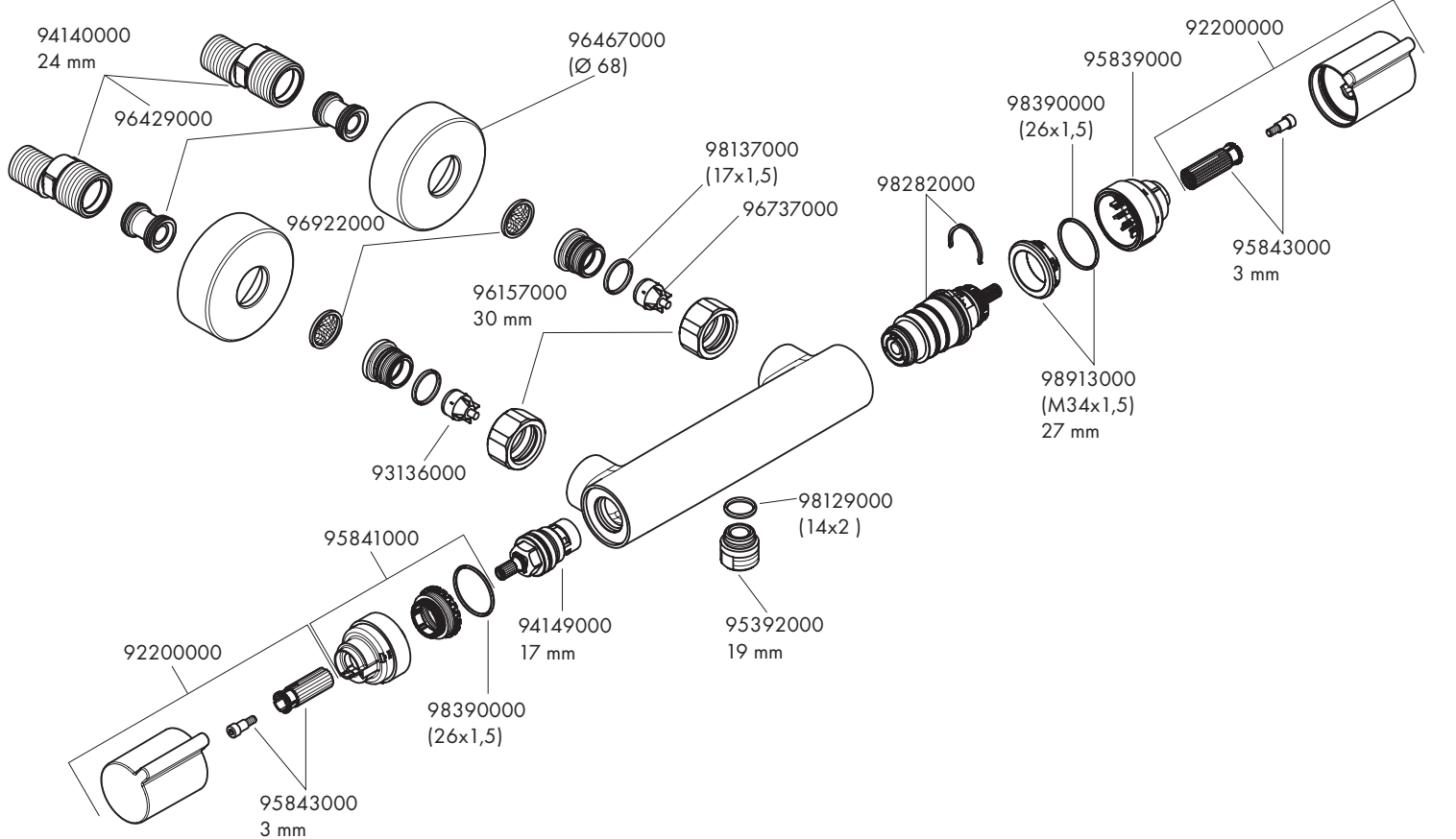

---

**hansgrohe**

Hansgrohe · AustraÙe 5 · 9 · D-77761 Schiltach · Telefon +49 (0) 78 36/51-1282 · Telefax +49 (0) 7836/511440  
E-Mail: [info@hansgrohe.com](mailto:info@hansgrohe.com) · Internet: [www.hansgrohe.com](http://www.hansgrohe.com)

04/2026  
9.02361.TM