

**EN** Instructions for use / Assembly instructions

**DE** Gebrauchsanleitung / Montageanleitung

**2**

**3**

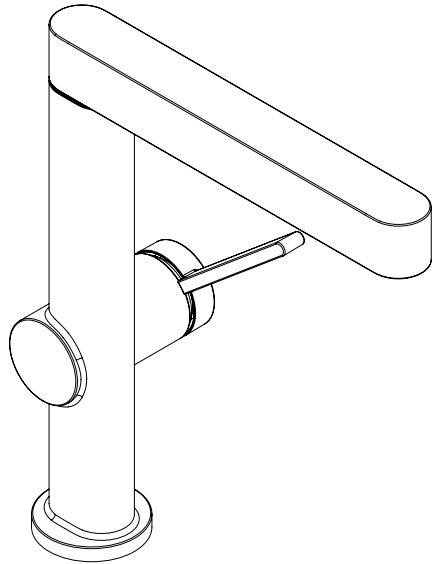

**Finoris 230 2jet**  
76063XX3 / 76063XX9



## Safety Notes

- ⚠ Gloves should be worn during installation to prevent crushing and cutting injuries.
- ⚠ The product may only be used for bathing, hygienic and body cleaning purposes.
- ⚠ The hot and cold supplies must be of equal pressures.

## Installation Instructions

- Prior to installation, inspect the product for transport damages. After it has been installed, no transport or surface damage will be honoured.
- The pipes and the fixture must be installed, flushed and tested as per the applicable standards.
- The plumbing codes applicable in the respective countries must be observed.
- The drain valve may only be installed in basins with an overflow opening.
- The drain valve must only be used as intended. It is not allowed to attach other objects to the drain valve, for example a semi-pedestal.

## Technical Data

Operating pressure:	max. 1 MPa
Recommended operating pressure:	0,1 - 0,5 MPa
Test pressure:	1,6 MPa
	(1 MPa = 10 bar = 147 PSI)
Hot water temperature:	max. 60 °C
Thermal disinfection:	70 °C / 4 min
The product is exclusively designed for drinking water!	

## Symbol description



Do not use silicone containing acetic acid!



**Adjustment** (see page 7)

To adjust the hot water limiter. Using a hot water limiter in combination with a continuous flow water heater is not recommended.



**Maintenance** (see page 11)

The check valves must be checked regularly according to EN 806-5 in accordance with national or regional regulations (at least once a year).



**Dimensions** (see page 8)



**Flow diagram** (see page 8)



**Spare parts** (see page 9)

XX = Colors  
 00 = Chrome Plated  
 67 = Matt Black  
 70 = Matt White



**Cleaning** (see page 10)



**Operation** (see page 11)

Hansgrohe recommends not to use as drinking water the first half liter of water drawn in the morning or after a prolonged period of non-use.

Fault	Cause	Remedy
Insufficient water	- Aerator calcified, dirty	- Clean aerator, replace as necessary
Mixer stiff	- Cartridge defective, calcified	- Exchange cartridge
Mixer dripping	- Cartridge defective	- Exchange cartridge
Water escaping in area of swivel spout	- O-ring defective	- Exchange O-ring
Water escaping at the threaded base	- connection hoses not completely screwed into basic body	- Tighten connection hoses by hand
	- O-ring at the connection hose defective.	- Exchange O-ring
Hot water temperature too low	- Hot water limiter incorrectly set	- Set hot water limiter



## Sicherheitshinweise

- ⚠ Bei der Montage müssen zur Vermeidung von Quetsch- und Schnittverletzungen Handschuhe getragen werden.
- ⚠ Das Produkt darf nur zu Bade-, Hygiene- und Körperreinigungszwecken eingesetzt werden.
- ⚠ Große Druckunterschiede zwischen den Kalt- und Warmwasseranschlüssen müssen ausgeglichen werden.

## Montagehinweise

- Vor der Montage muss das Produkt auf Transportschäden untersucht werden. Nach dem Einbau werden keine Transport- oder Oberflächenschäden anerkannt.
- Die Leitungen und die Armatur müssen nach den gültigen Normen montiert, gespült und geprüft werden.
- Die in den Ländern jeweils gültigen Installationsrichtlinien sind einzuhalten.
- Das Ablaufventil darf nur in Waschbecken mit Überlauf eingesetzt werden.
- Das Ablaufventil darf nur zum bestimmungsgemäßen Gebrauch verwendet werden. Das Befestigen von anderen Gegenständen z. B. einer Halbsäule an dem Ablaufventil ist nicht zulässig.

## Technische Daten

Betriebsdruck:	max. 1 MPa
Empfohlener Betriebsdruck:	0,1 - 0,5 MPa
Prüfdruck:	1,6 MPa
	(1 MPa = 10 bar = 147 PSI)
Heißwassertemperatur:	max. 60 °C
Thermische Desinfektion:	70 °C / 4 min

Das Produkt ist ausschließlich für Trinkwasser konzipiert!

## Symbolerklärung



Kein essigsäurehaltiges Silikon verwenden!



**Justierung** (siehe Seite 7)

Einstellen der Warmwasserbegrenzung. In Verbindung mit Durchlauferhitzern ist eine Warmwassersperre nicht zu empfehlen.



**Wartung** (siehe Seite 11)

Rückflussverhinderer müssen gemäß EN 806-5 regelmäßig in Übereinstimmung mit nationalen oder regionalen Bestimmungen auf ihre Funktion geprüft werden (mindestens einmal jährlich).



**Maße** (siehe Seite 8)



**Durchflussdiagramm** (siehe Seite 8)



**Serviceteile** (siehe Seite 9)

XX = Farbcodierung

00 = Chrom

67 = Mattschwarz

70 = Mattweiß



**Reinigung** (siehe Seite 10)



**Bedienung** (siehe Seite 11)

Hansgrohe empfiehlt, morgens oder nach längeren Stagnationszeiten den ersten halben Liter nicht als Trinkwasser zu verwenden.

Störung	Ursache	Ambilfe
Wenig Wasser	- Luftsprudler verkalkt, verschmutzt	- Luftsprudler reinigen / austauschen
Armatur schwergängig	- Kartusche defekt, verkalkt	- Kartusche austauschen
Armatur tropft	- Kartusche defekt	- Kartusche austauschen
Wasseraustritt im Bereich des Schwenkauslaufes	- O-Ring defekt	- O-Ring austauschen
Wasseraustritt am Befestigungsschaft	- Anschlusschläuche nicht ganz in den Grundkörper eingeschraubt	- Anschlusschläuche von Hand festziehen
	- O-Ring am Anschlusschlauch defekt	- O-Ring austauschen
Zu niedrige Warmwassertemperatur	- Warmwasserbegrenzung falsch eingestellt	- Warmwasserbegrenzung einstellen

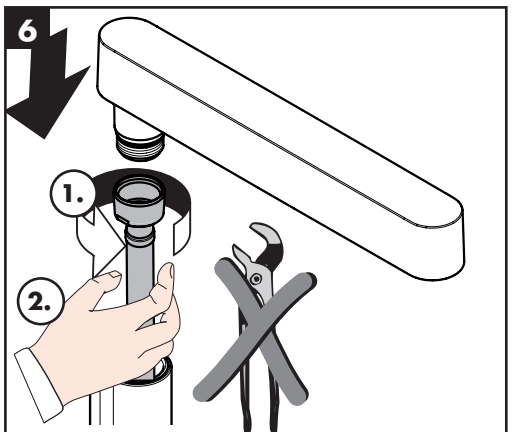
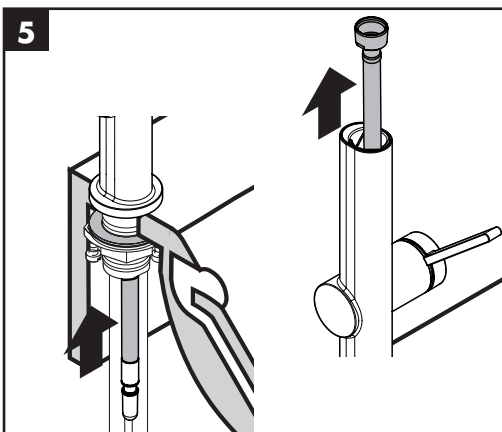
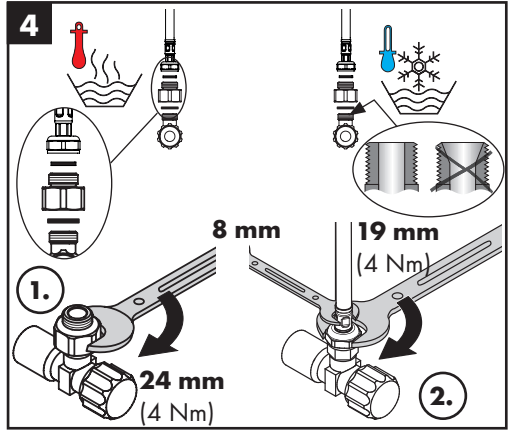
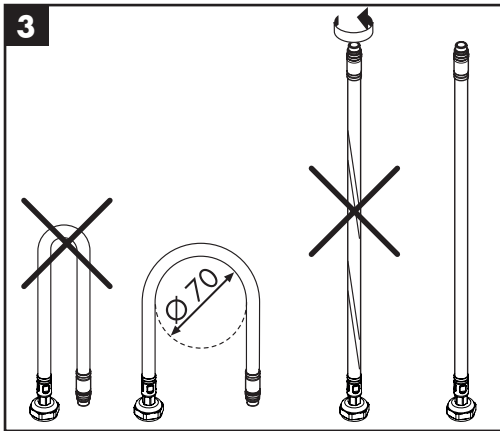
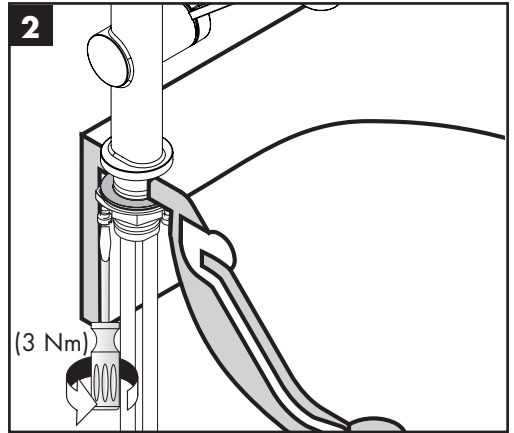
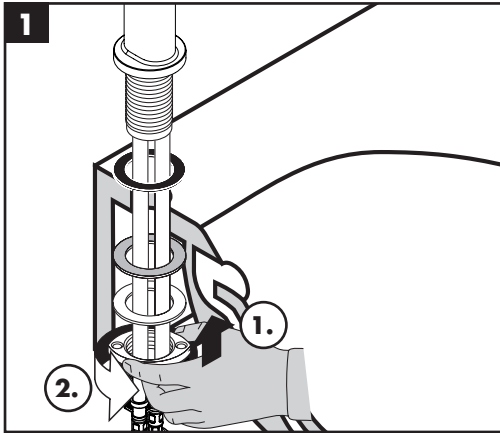

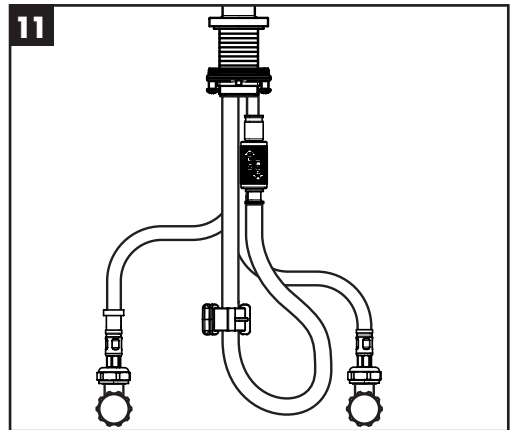
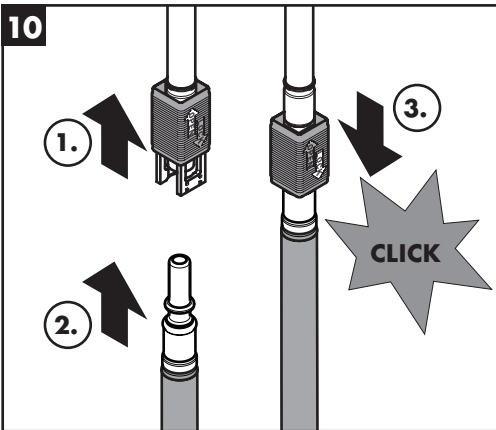
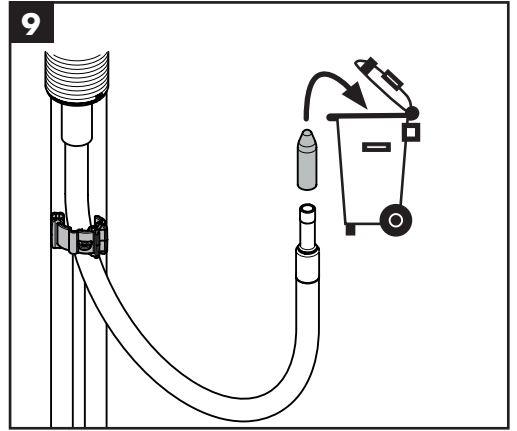
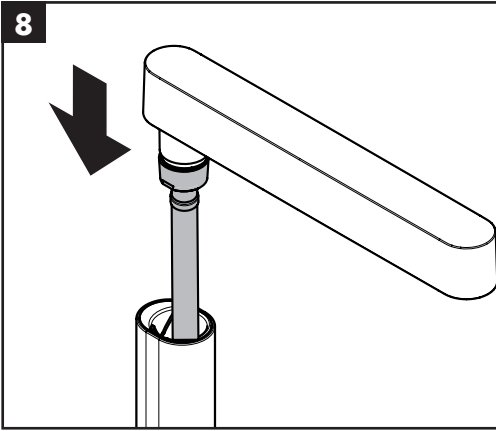
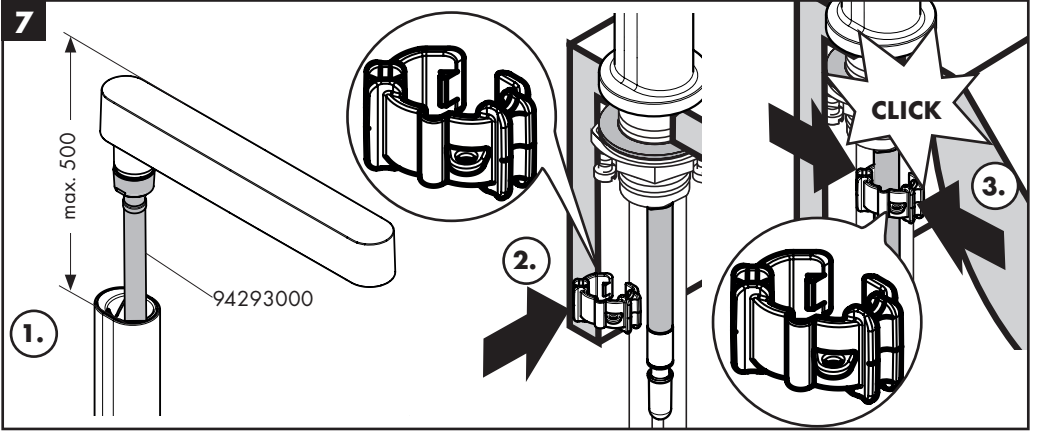

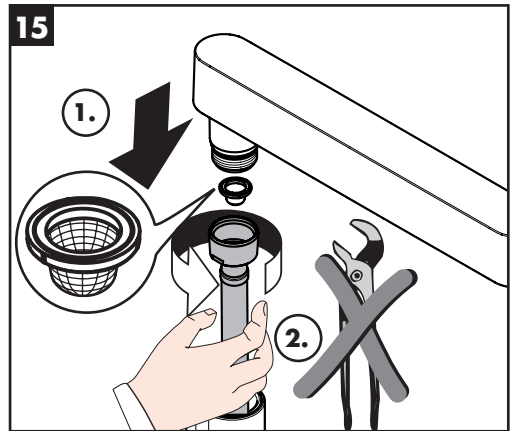
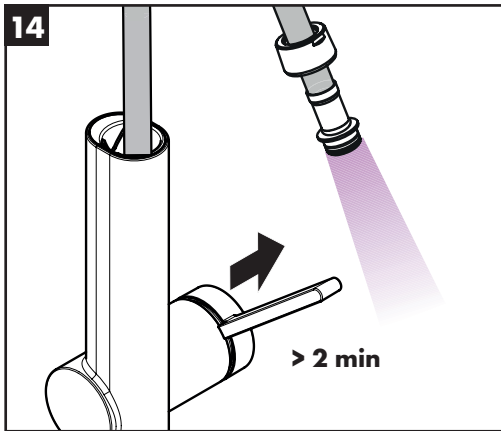
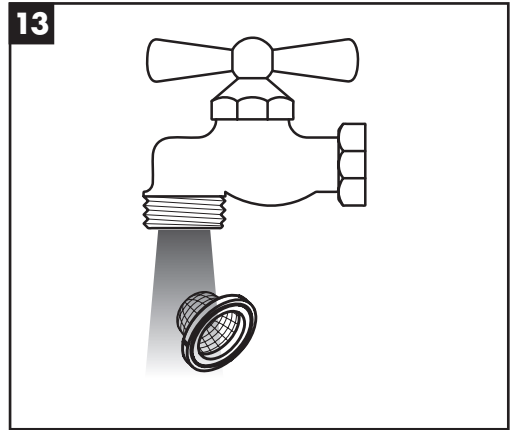
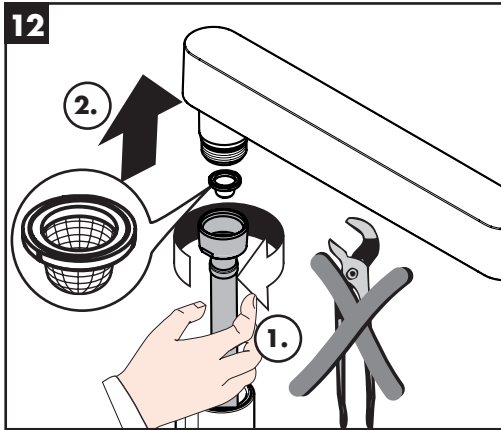

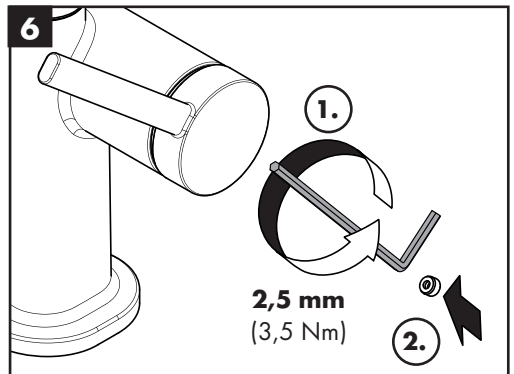
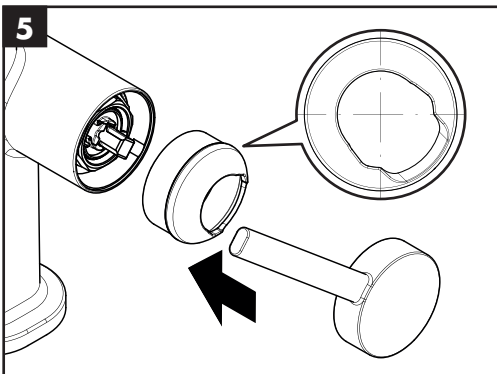
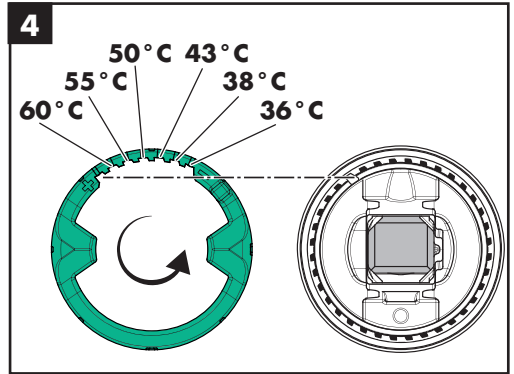
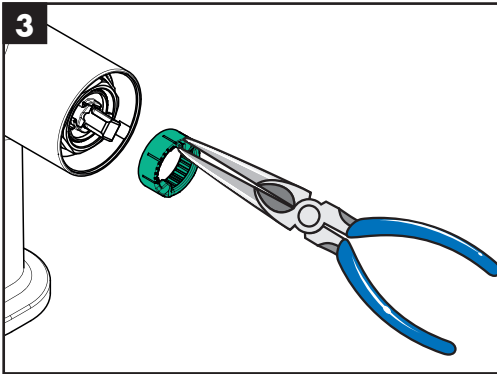
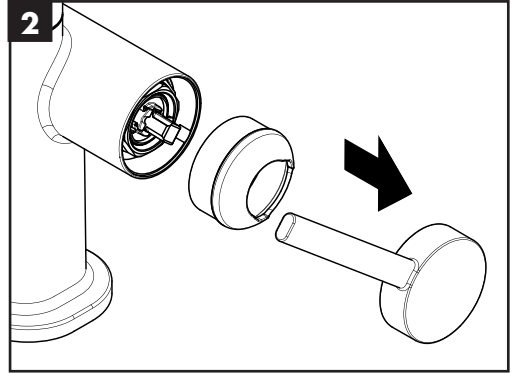
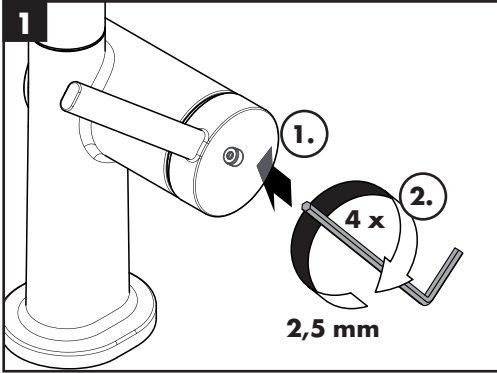



# Finoris 230 2jet

76063XX3 / 76063XX9

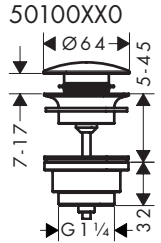
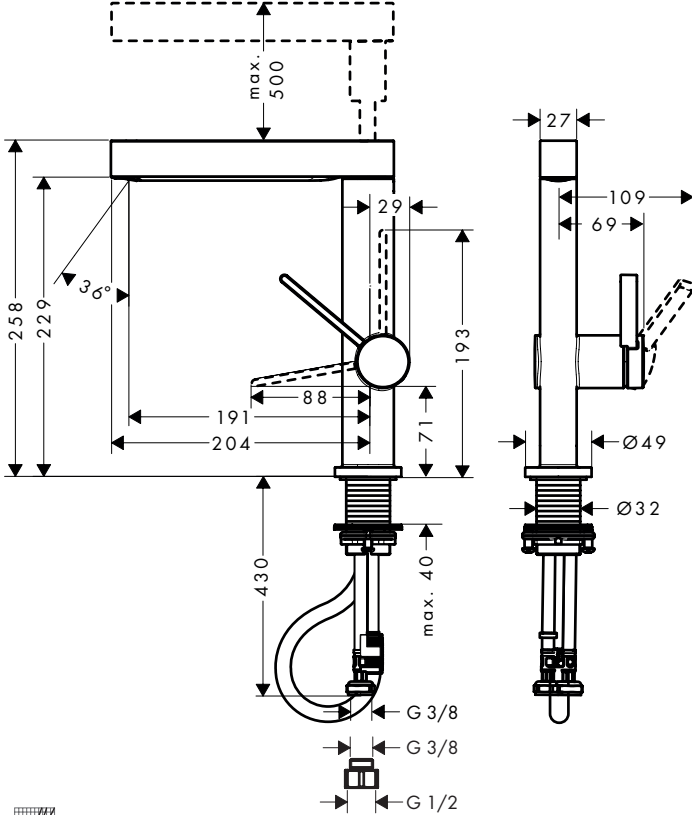

# Finoris 230 2jet

76063XX3 / 76063XX9

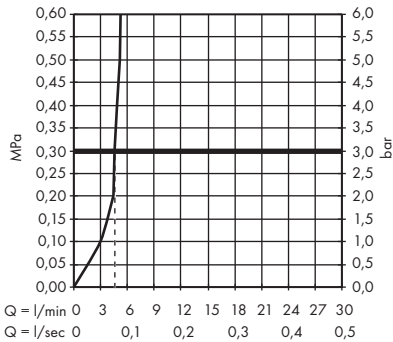





**Finoris 230 2jet**  
76063XX3 / 76063XX9

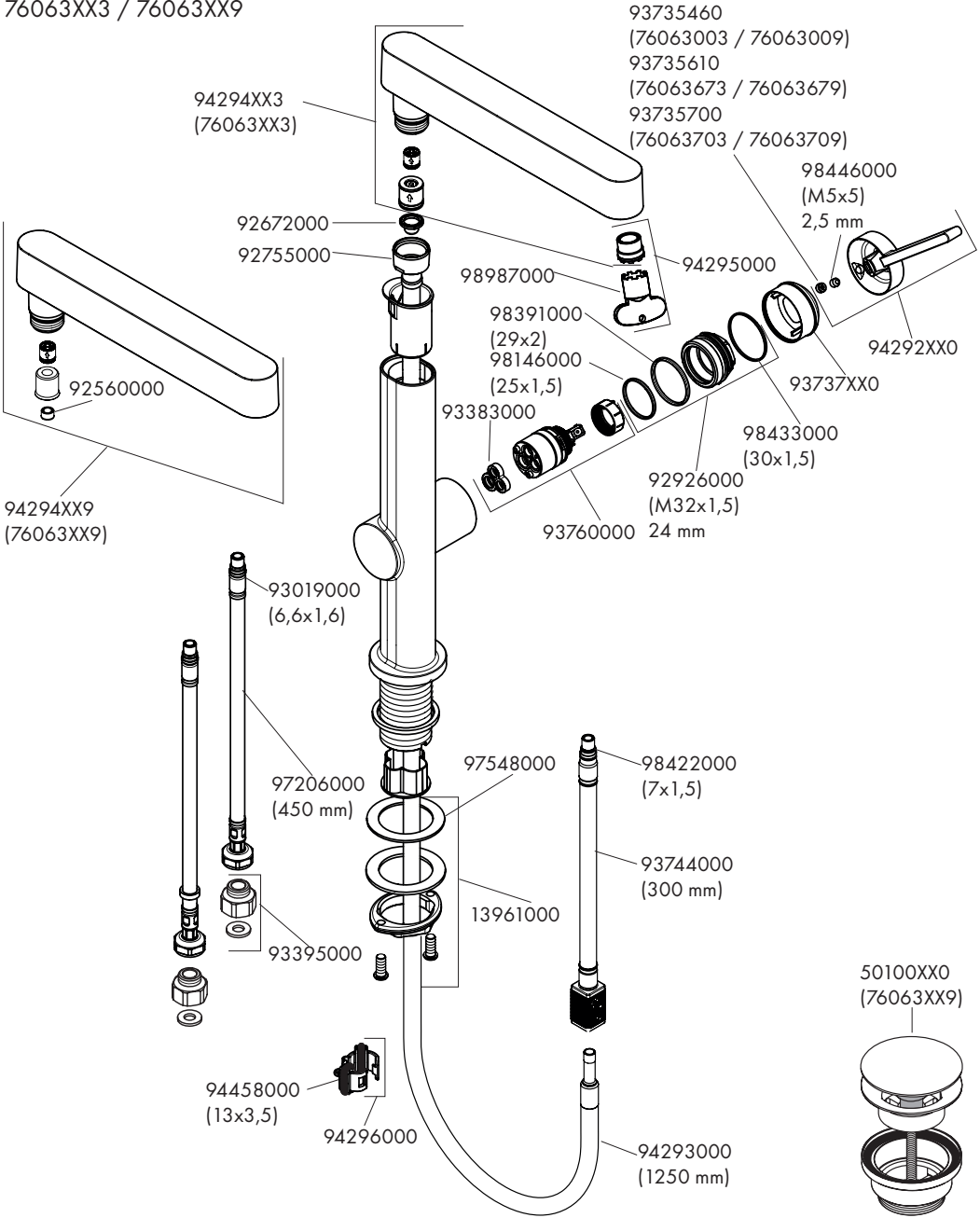



[www.hansgrohe.com/cleaning-recommendation](http://www.hansgrohe.com/cleaning-recommendation)

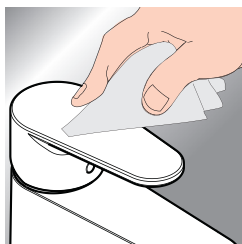

\*[www.hansgrohe.com/warranty](http://www.hansgrohe.com/warranty)



**EN** Cleaning recommendation / Warranty / Contact

**DE** Reinigungsempfehlung / Garantie / Kontakt

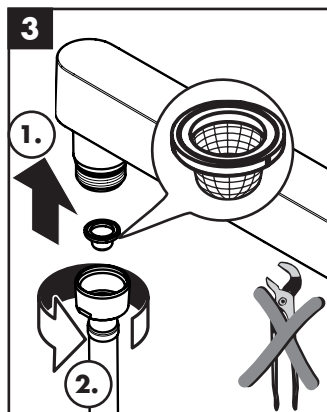
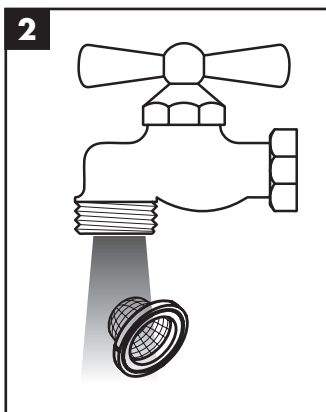
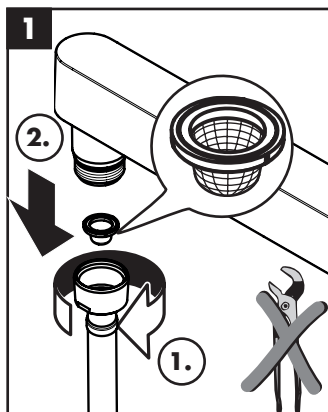

76063XX9

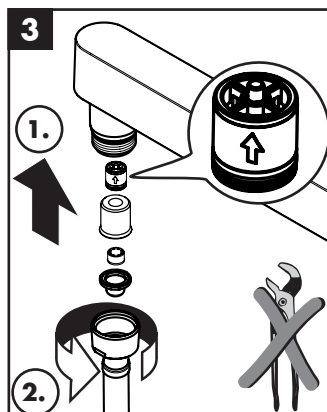
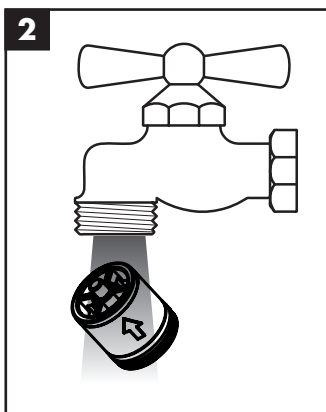
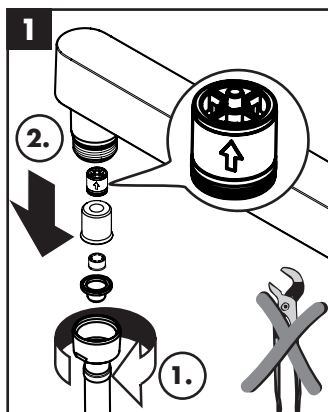

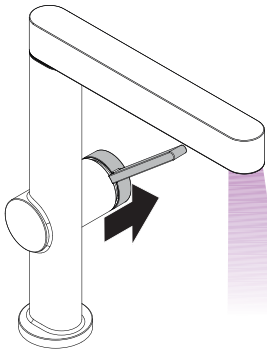
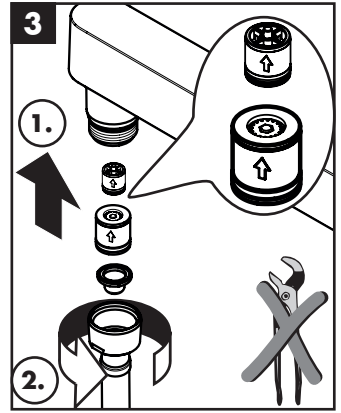
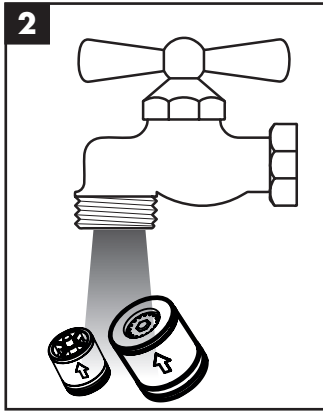
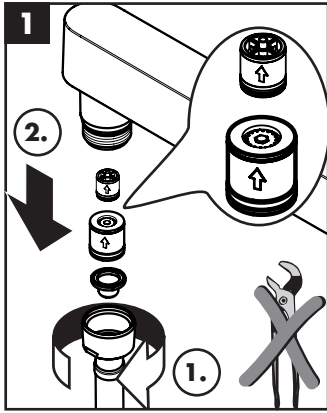

open / öffnen

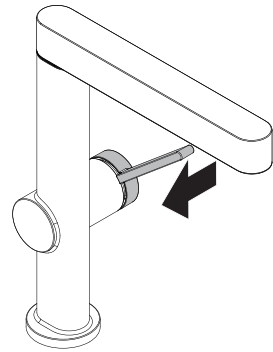
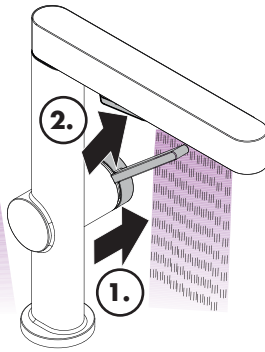

close / schließen

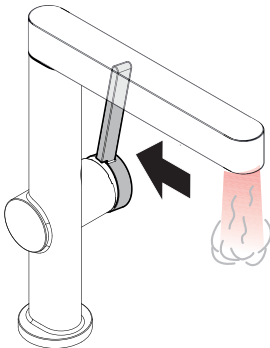

hot / warm

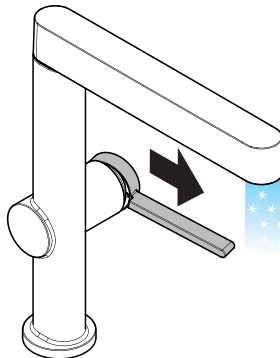

cold / kalt

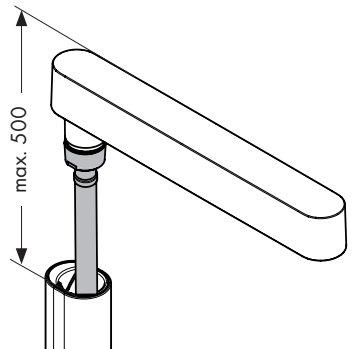

---

**hansgrohe**

Hansgrohe · Auestraße 5 · 9 · D-77761 Schiltach · Telefon +49 (0) 78 36/51-1282 · Telefax +49 (0) 7836/511440  
E-Mail: [info@hansgrohe.com](mailto:info@hansgrohe.com) · Internet: [www.hansgrohe.com](http://www.hansgrohe.com)

01/2025  
9,07983,61