

ZH 用户手册 / 组装说明	2
EN Instructions for use / assembly instructions	4
DE Gebrauchsanleitung / Montageanleitung	6

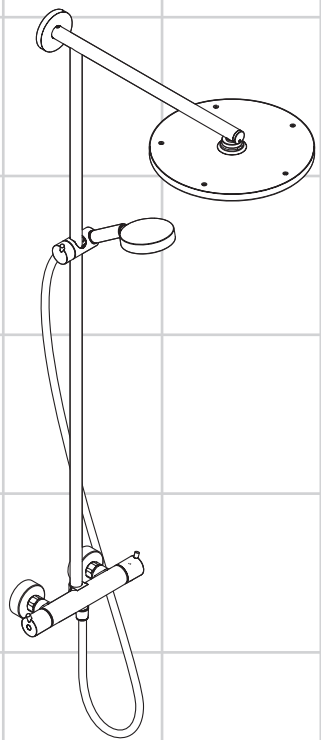

Raindance Showerpipe
27218000



安全技巧

- △ 装配时为避免挤压和切割受伤，必须戴上手套。
- △ 头顶莲蓬头夹持杆只为夹持头顶莲蓬头而设计，不得让其承载其它物品！
- △ 淋浴系统只允许作为洗浴、卫生和洁身之用。
- △ 不得让儿童和肢体、精神和/或意识有障碍的成人在不受监管的情况下使用淋浴系统。受酒精或毒品影响的人员不得使用淋浴系统。
- △ 必须避免让身体敏感部位（如眼睛）接触到莲蓬头喷水。必须保持莲蓬头与人头之间有足够的距离。
- △ 该产品不得作扶柄使用。必须安装单独的扶柄。
- △ 冷热水管间过大的压力差必须予以平衡。

安装提示

- 安装前必须检查产品是否受到运输损害。安装后将不认可运输损害或表面损伤。
- 管道和阀门必须根据通用标准进行安装、冲洗和检查。
- 请遵守当地国家现行的安装规定。
- 本安装说明中所规定的安装尺寸理想用于身高 1700 mm 左右的人士。尺寸可根据需要进行修改。在这种情况下，您必须留意，如果安装高度改变，则花洒到地板的最小高度也随之改变，且必须考虑到连接尺寸的改变。
- 在安装产品的位置，安装人员必须确保安装面的墙面是平的（没有突出物或瓷砖没有突起），墙体结构适合产品的安装并没有弱点。包装内的膨胀螺丝只适用于混凝土墙体。对于其他墙体结构必须咨询膨胀螺丝生产商的建议。
- 为了防止管道中的脏东西冲入花洒内，与手持花洒包装在一起的滤柱（97708000）必须安装。如果想要更大的出水量，可用滤网（94246000）代替滤柱（97708000）。这些脏东西会影响手持花洒的功能或损坏手持花洒的功能部件，由此引起的损失汉斯格雅公司概不负责。
- 本产品并非设计来与蒸气浴连接使用！
- 紧急情况下，可使用细的锯子将下方区域中阀门与头顶莲蓬头之间的管子锯短。
- 如果连续流热水器导致任何问题，或者出现了不同的水压，您必须在冷水端安装水流限制器（单独订购，商品编号 97510000）。

技术参数

工作压强:	最大 1 MPa
推荐工作压强:	0,1 – 0,5 MPa
测试压强:	1,6 MPa
(1 MPa = 10 bar = 147 PSI)	
热水温度:	最大 80°C
推荐热水温度:	65°C
中心距离:	150 ± 12mm
连接管线 G 1/2:	左热右冷
热力消毒:	最大 70°C / 4 分钟

自动防止回流
该产品专为饮用水设计！

符号说明



请勿使用含有乙酸的硅！

max.
≈ 42°C

安全功能 (参见第页 14)

恒温阀芯的安全功能可以预先设定所希望的最高出水温度，例如最高温度为 42°C



校准 (参见第页 13)

安装完成后必须检查调温器的出水温度。如在取水处测量所得的温度与调温器上设定的温度有偏差，那么必须进行调整。



流量示意图

(参见第页 16)

- ① 顶置花洒
- ② 手持花洒



操作 (参见第页 22)

请在使用喷头后略微倾斜，排空其中水分。



保养 (参见第页 20)

单向阀必须在符合国家或当地的法律的情况下按照DIN EN 1717定期检查（至少一年一次）。为了保证恒温器的稳定运转，请务必定期从最热到最冷转动调温器。



清洗 (参见第页) 并附有小手册



备用零件 (参见第页 24)



选装附件 (不在供货范围内)

匹配瓷砖的圆盘 镀铬 #98681000



大小 (参见第页 15)

问题	原因	补救
龙头出水量小	- 水压不足 - 调压器过滤网脏污	- 检查总水压 - 清洁龙头前面和MTC恒温阀芯的过滤网。
串水，在龙头关闭的状态下，热水被强迫流入冷水管路，或者相反。	- 花洒过滤器元件有垃圾堵塞 - 单向阀有垃圾堵塞或漏水	- 清洗花洒和软管间的过滤密封件 - 清洗单向阀，如有必要则更换新的
龙头出水温度和温度设定的不符	- 恒温器未被调节 - 热水温度过低	- 调节恒温器 - 将热水温度从42°C升高到65°C
水温无法调节	- 恒温阀芯表面结垢	- 更换-恒温阀芯
使用恒温龙头后，燃气热水器不工作	- 过滤网有垃圾堵塞 - 单向阀装反 - 手持花洒的流量限制器没有去除	- 清洗过滤网/更换过滤网 - 正确安装单向阀 - 去除流量限制器



安装 参见第页 8



Safety Notes

- △ Gloves should be worn during installation to prevent crushing and cutting injuries.
- △ The arm of the shower head is intended only to hold the shower head. Do not load it down with other objects!
- △ The shower system may only be used for bathing, hygienic and body cleaning purposes.
- △ Children as well as adults with physical, mental and/or sensoric impairments must not use this product without proper supervision. Persons under the influence of alcohol or drugs are prohibited from using this product.
- △ Do not allow the streams of the shower touch sensitive body parts (such as your eyes). An adequate distance must be kept between the shower and you.
- △ The product may not be used as a holding handle. A separate handle must be installed.
- △ The hot and cold supplies must be of equal pressures.

Installation Instructions

- Prior to installation, inspect the product for transport damages. After it has been installed, no transport or surface damage will be honoured.
- The pipes and the fixture must be installed, flushed and tested as per the applicable standards.
- The plumbing codes applicable in the respective countries must be observed.
- The installation dimensions stated in these installation instructions are ideal for people of approximately 1700 mm in body height. The dimensions can be altered if required. In this case, pay attention to the fact that a change of installation height will also change the minimum height, and that the altered mounting dimensions must be taken into consideration.
- Where the contractor mounts the product, he should ensure that the entire area of the wall to which the mounting plate is to be fitted, is flat (no projecting joints or tiles sticking out), that the structure of the wall is suitable for the installation of the product and has no weak points. The enclosed screws and dowels are only suitable for concrete. For another wall constructions the manufacturer's indications of the dowel manufacturer have to be taken into account.

- The filter insert (97708000) must be used to ensure the standard flow rate and to protect the hand shower against incoming dirt by pipework. Do you want a larger water flow rate, then you must use the filter packing (94246000) instead of the filter insert (97708000). Incoming dirt leads to defects or/and can damage parts of the hand shower; such caused faults voids all liability and guarantee claims.
- The product is not designed to be used with steam baths!
- If required, the bottom part of the pipe between the fixture and the shower head can be shortened with a fine-toothed saw.
- If the continuous water heater causes any problems, or you have different water pressures you must install a water limiter to the cold supply, (ordered separately, article number 97510000).

Technical Data

Operating pressure:	max. 1 MPa
Recommended operating pressure:	0,1 - 0,5 MPa
Test pressure:	1,6 MPa
(1 MPa = 10 bar = 147 PSI)	
Hot water temperature:	max. 80 °C
Recommended hot water temp.:	65 °C
Centre distance:	150±12mm
Connections G 1/2:	cold right - hot left
Thermal disinfection:	max. 70 °C / 4 min
Safety against backflow	

The product is exclusively designed for drinking water!

Symbol description



Do not use silicone containing acetic acid!

max. ≈ 42 °C **Safety Function** (see page 14)
The desired maximum temperature for example max. 42° C can be pre-set thanks to the safety function.



Adjustment (see page 13)

After the installation, the output temperature of the thermostat must be checked. A correction is necessary if the temperature measured at the output differs from the temperature set on the thermostat.



Flow diagram

(see page 16)

- ① overhead shower
- ② Hand shower



Operation (see page 22)

To empty the overhead shower after use, hold it in a slightly inclined position.



Maintenance (see page 20)

The check valves must be checked regularly according to DIN EN 1717 in accordance with national or regional regulations (at least once a year). To guarantee the smooth running of the thermostat, it is necessary from time to time to turn the thermostat from total hot to total cold.



Cleaning (see page) and enclosed brochure



Spare parts (see page 24)



Special accessories (order as an extra)

tile-matching-disk chrome plated
#98681000



Dimensions (see page 15)

Fault	Cause	Remedy
Insufficient water	- Supply pressure inadequate	- Check water pressure (If a pump has been installed check to see if the pump is working).
	- Regulator filter dirty	- Clean filter in front of the mixer and on the MTC-thermo cartridge
	- filter insert shower dirty	- Clean filter insert between shower and hose
Crossflow, hot water being forced into cold water pipe, or vice versa, when mixer is closed	- Backflow preventers dirty or leaking	- Clean backflow preventers, exchange if necessary
Spout temperature does not correspond with temperature set	- Thermostat has not been adjusted	- Adjust thermostat
	- Hot water temperature too low	- Increase hot water temperature to 42 °C to 65 °C
Temperature regulation not possible	- thermo cartridge calcified	- Exchange thermo cartridge
Instantaneous heater didn't work with thermostat	- Filters are dirty	- Clean the filter / exchange filter
	- check valve hasn't moved back	- Exchange check valves
	- Flow limiter in handshower isn't removed	- Remove flow limiter



Assembly see page 8



Sicherheitshinweise

- ⚠ Bei der Montage müssen zur Vermeidung von Quetsch- und Schnittverletzungen Handschuhe getragen werden.
- ⚠ Der Kopfbrausearm ist nur für das Halten der Kopfbrause ausgelegt, er darf nicht mit weiteren Gegenständen belastet werden!
- ⚠ Das Produkt darf nur zu Bade-, Hygiene- und Körperreinigungszwecken eingesetzt werden.
- ⚠ Kinder, sowie Erwachsene mit körperlichen, geistigen und / oder sensorischen Einschränkungen dürfen das Produkt nicht unbeaufsichtigt benutzen. Personen, die unter Alkohol- oder Drogeneinfluss stehen, dürfen das Produkt nicht benutzen.
- ⚠ Der Kontakt der Brausestrahlen mit empfindlichen Körperstellen (z. B. Augen) muss vermieden werden. Es muss ein ausreichender Abstand zwischen Brause und Körper eingehalten werden.
- ⚠ Das Produkt darf nicht als Haltegriff benutzt werden. Es muss ein separater Haltegriff montiert werden.
- ⚠ Große Druckunterschiede zwischen den Kalt- und Warmwasseranschlüssen müssen ausgeglichen werden.

Montagehinweise

- Vor der Montage muss das Produkt auf Transportschäden untersucht werden. Nach dem Einbau werden keine Transport- oder Oberflächenschäden anerkannt.
- Die Leitungen und die Armatur müssen nach den gültigen Normen montiert, gespült und geprüft werden.
- Die in den Ländern jeweils gültigen Installationsrichtlinien sind einzuhalten.
- Die in der Montageanleitung angegebenen Montage Maße sind ideal für Personen von ca. 1700 mm Körpergröße und müssen gegebenenfalls angepasst werden. Hierbei ist darauf zu achten, dass sich bei geänderter Montagehöhe die Mindesthöhe ändert und die Änderung der Anschlussmaße berücksichtigt werden müssen.
- Bei der Montage des Produktes durch qualifiziertes Fachpersonal ist darauf zu achten, dass die Befestigungsfläche im gesamten Bereich der Befestigung plan ist (keine vorstehenden Fugen oder Fliesenversatz), der Wandaufbau für eine Montage des Produktes geeignet ist und keine Schwachstellen aufweist. Die beigelegten Schrauben und Dübel sind nur für

Beton geeignet. Bei anderen Wandaufbauten sind die Herstellerangaben des Dübelherstellers zu beachten.

- Der beigelegte Filtereinsatz (97708000) muss eingebaut werden, um den Normdurchfluss der Handbrause zu gewährleisten und um Schmutzeinspülungen aus dem Leitungsnetz zu vermeiden. Wird ein größerer Wasserdurchfluss gewünscht, muss anstelle des Filtereinsatzes (97708000) die Siebdichtung (94246000) eingesetzt werden. Schmutzeinspülungen können die Funktion beeinträchtigen und/oder zu Beschädigungen an Funktionsteilen der Handbrause führen, für hieraus ergebende Schäden haftet Hansgrohe nicht.
- Das Produkt ist nicht für die Verwendung in Verbindung mit einem Dampfbad vorgesehen!
- Im Notfall kann das Rohr zwischen Armatur und Kopfbrause im unteren Bereich mit einer feinen Säge gekürzt werden.
- Bei Problemen mit dem Durchlauferhitzer oder großen Druckunterschieden muss eine optional erhältliche Drossel (Artikelnummer 97510000) in den Kaltwasserzulauf eingesetzt werden.

Technische Daten

Betriebsdruck:	max. 1 MPa
Empfohlener Betriebsdruck:	0,1 - 0,5 MPa
Prüfdruck:	1,6 MPa
(1 MPa = 10 bar = 147 PSI)	
Heißwassertemperatur:	max. 80 °C
Empfohlene Heißwassertemperatur:	65 °C
Anschlussmaße:	150±12mm
Anschlüsse G 1/2:	kalt rechts - warm links
Thermische Desinfektion:	max. 70 °C / 4 min
Eigensicher gegen Rückfließen	

Das Produkt ist ausschließlich für Trinkwasser konzipiert!

Symbolerklärung



Kein essigsäurehaltiges Silikon verwenden!

max. $\approx 42^{\circ}\text{C}$ **Safety Function** (siehe Seite 14)
 Dank der Safety Function lässt sich die gewünschte Höchsttemperatur von z. B. max. 42 °C voreinstellen.



Einjustieren (siehe Seite 13)

Nach erfolgter Montage muss die Auslauftemperatur des Thermostaten überprüft werden. Eine Korrektur ist erforderlich wenn die an der Entnahmestelle gemessene Temperatur von der am Thermostaten eingestellten Temperatur abweicht.



Durchflussdiagramm

(siehe Seite 16)

- ① Kopfbrause
- ② Handbrause



Bedienung (siehe Seite 22)

Zum Entleeren der Kopfbrause diese nach dem Benutzen leicht schräg stellen.



Wartung (siehe Seite 20)

Rückflussverhinderer müssen gemäß DIN EN 1717 regelmäßig in Übereinstimmung mit nationalen oder regionalen Bestimmungen (DIN 1988 einmal jährlich) auf ihre Funktion geprüft werden. Um die Leichtgängigkeit der Regeleinheit zu gewährleisten, sollte der Thermostat von Zeit zu Zeit auf ganz warm und ganz kalt gestellt werden.



Reinigung (siehe Seite) und beiliegende Broschüre



Serviceteile (siehe Seite 24)



Sonderzubehör (nicht im Lieferumfang enthalten)

Fliesenausgleichsscheibe chrom
#98681000



Maße (siehe Seite 15)

Störung	Ursache	Abhilfe
Wenig Wasser	- Versorgungsdruck nicht ausreichend - Schmutzfangsieb der Regeleinheit verschmutzt - Filtereinsatz der Brause verschmutzt	- Leitungsdruck prüfen - Schmutzfangsiebe vor dem Thermostat und auf der Regeleinheit reinigen - Filtereinsatz zwischen Brause und Schlauch reinigen
Kreuzfluss, warmes Wasser wird bei geschlossener Armatur in die Kaltwasserleitung gedrückt oder umgekehrt	- Rückflussverhinderer verschmutzt / defekt	- Rückflussverhinderer reinigen ggf. austauschen
Auslauftemperatur stimmt nicht mit der eingestellten Temperatur überein	- Thermostat wurde nicht justiert - Zu niedrige Warmwassertemperatur	- Thermostat justieren - Warmwassertemperatur erhöhen auf 42 °C bis 65 °C
Temperaturregelung nicht möglich	- Regeleinheit verkalkt	- Regeleinheit austauschen
Durchlauferhitzer schaltet bei Thermostatbetrieb nicht ein	- Schmutzfangsiebe verschmutzt - Rückflussverhinderer sitzt fest - Drossel in der Handbrause nicht ausgebaut	- Schmutzfangsiebe reinigen / austauschen - Rückflussverhinderer austauschen - Drossel aus der Handbrause entfernen



Montage siehe Seite 8

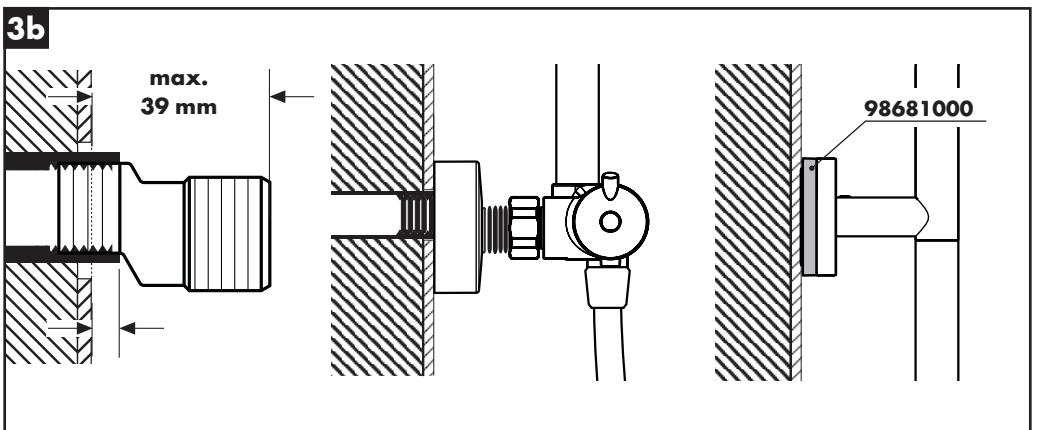
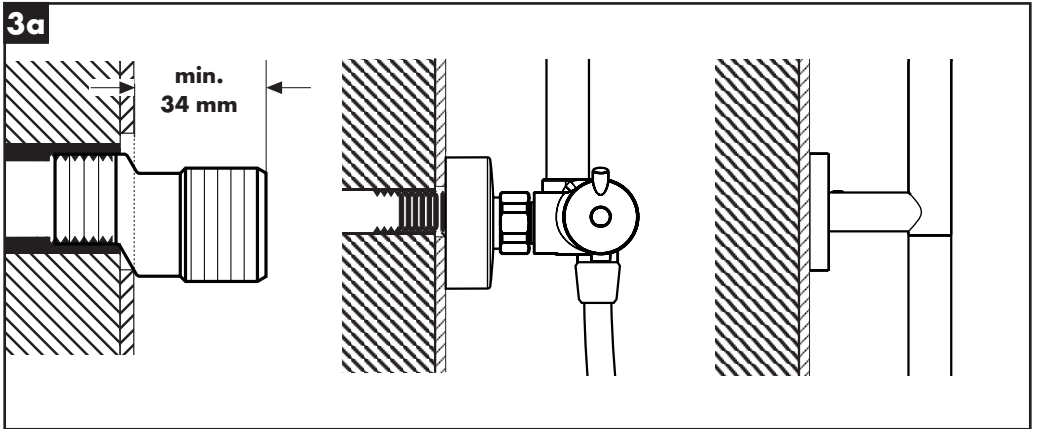
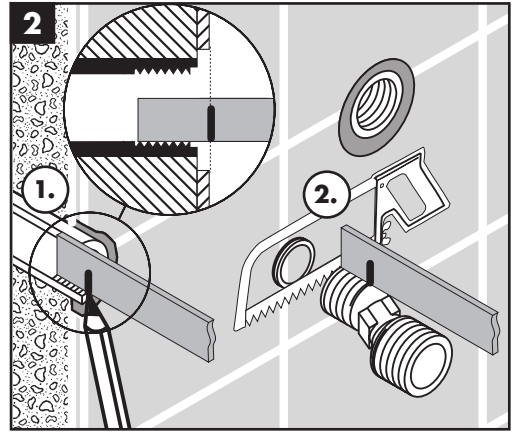
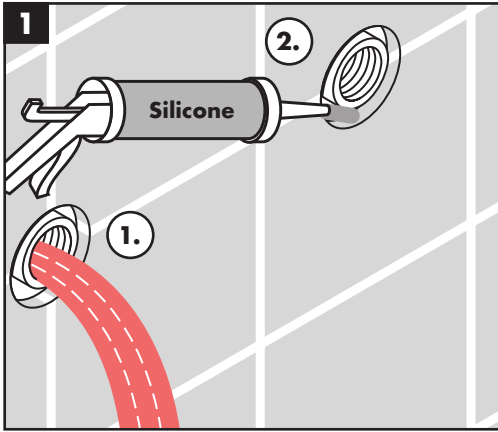

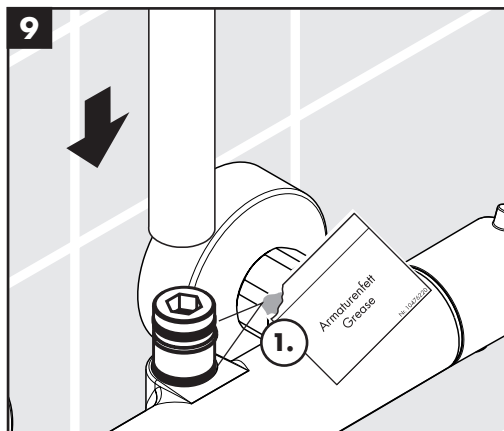
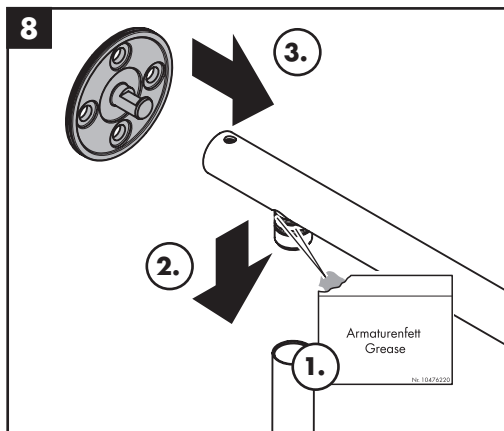
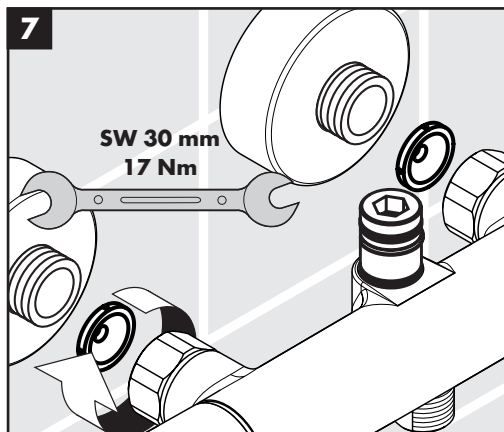
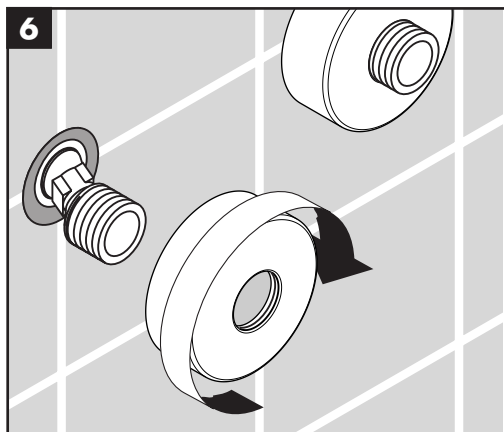
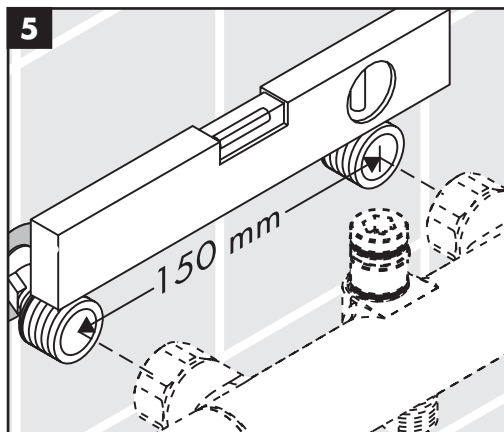
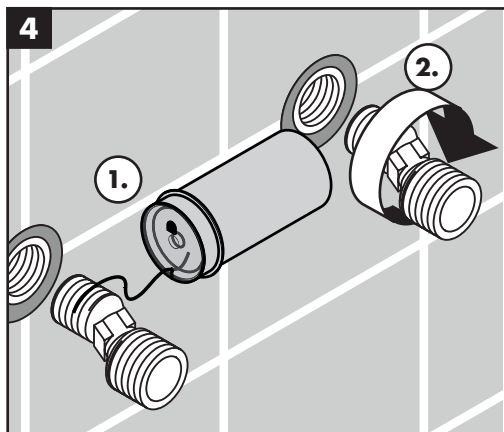

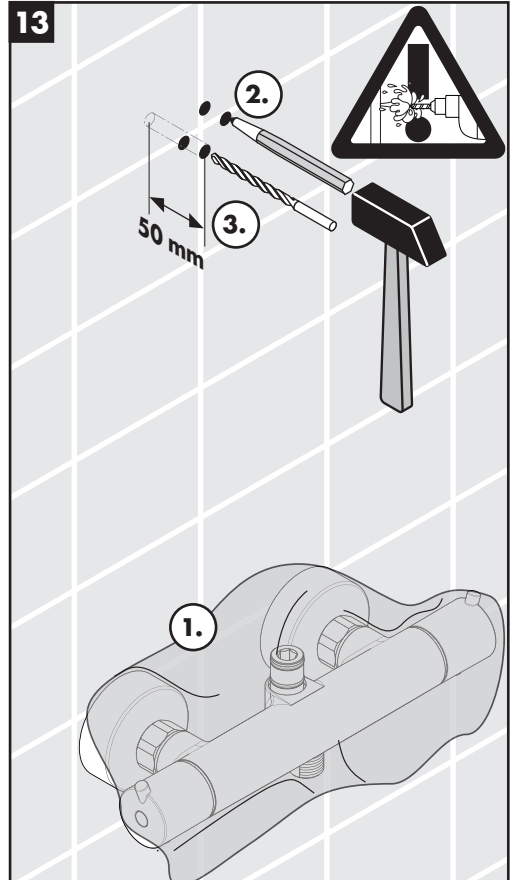
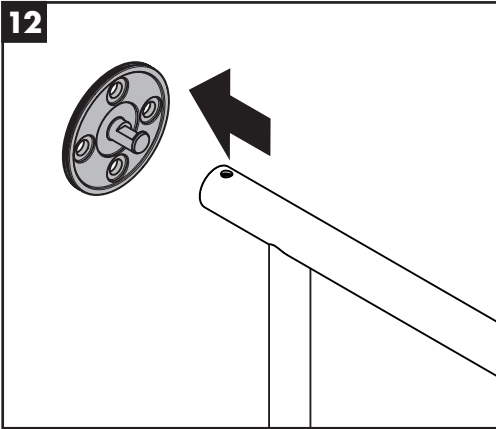
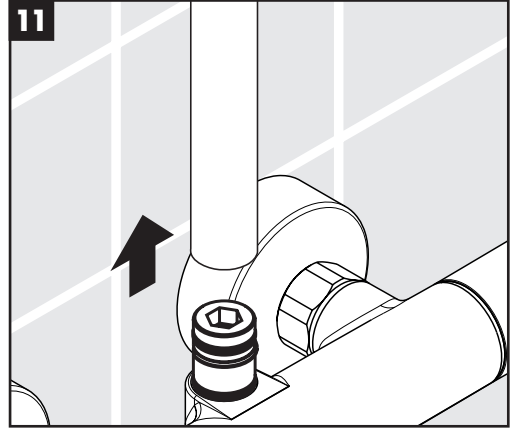
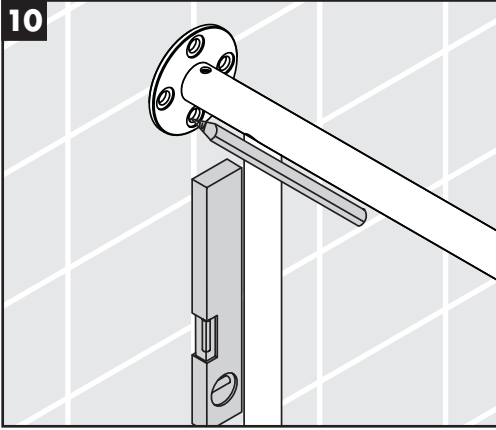

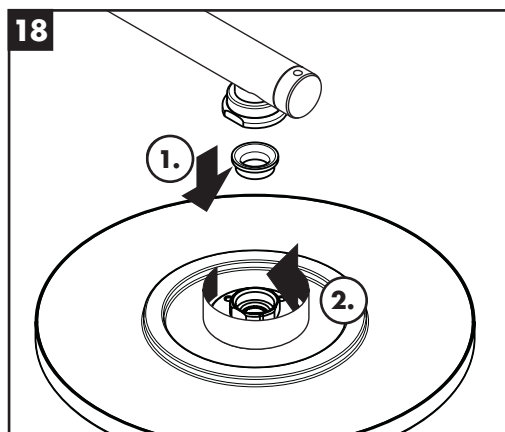
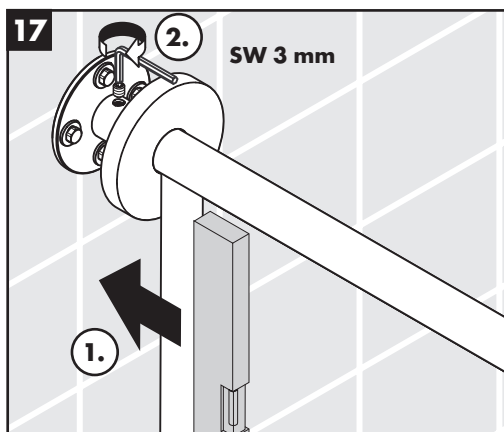
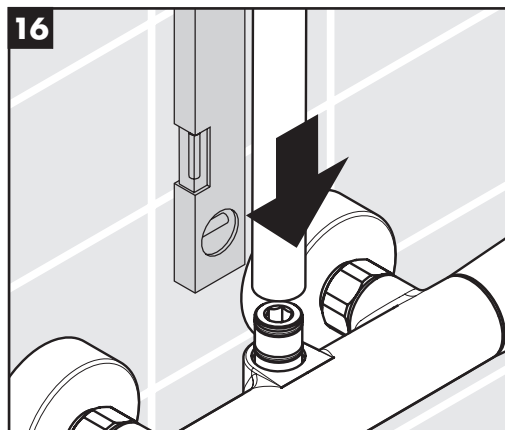
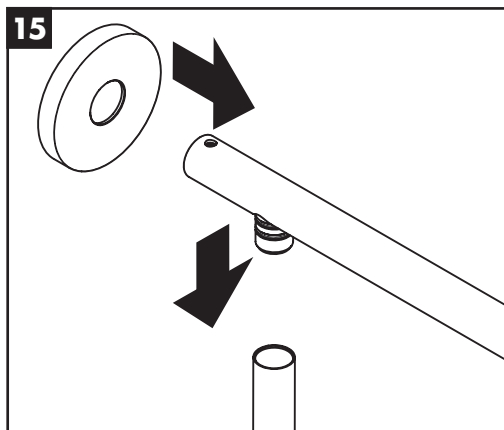
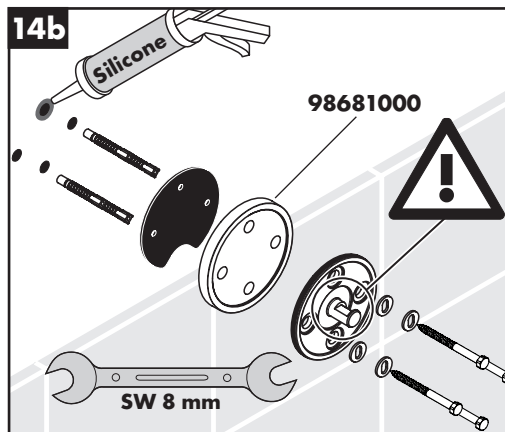
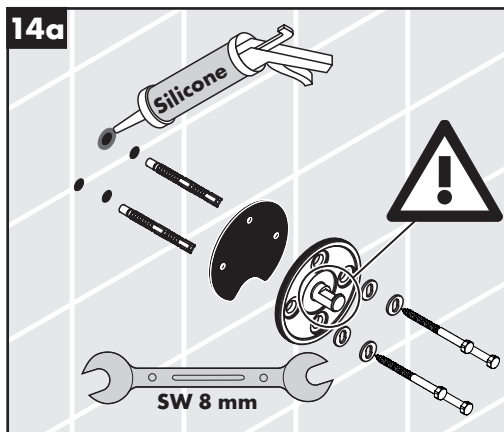

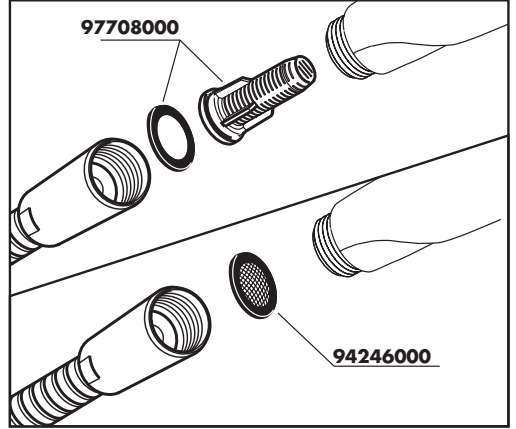
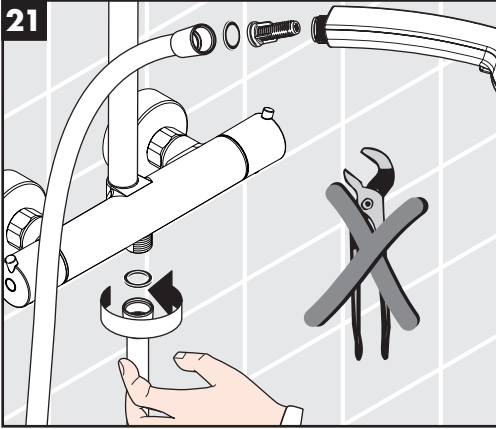
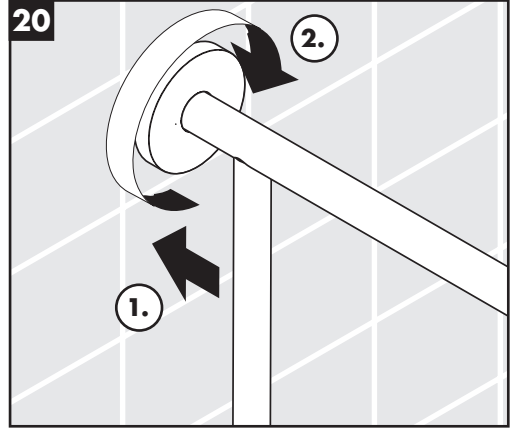
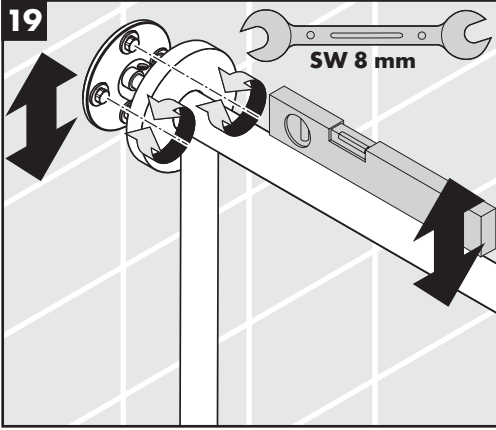

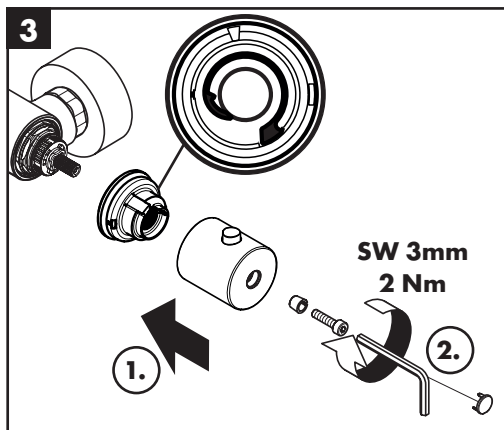
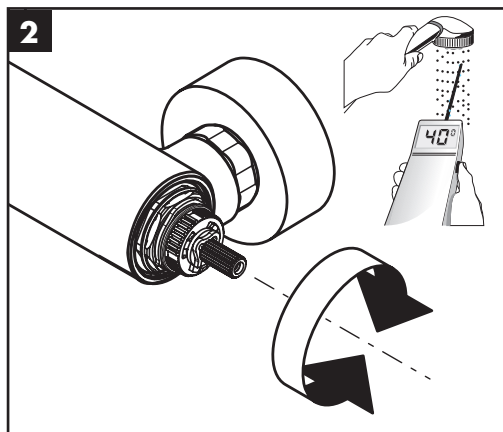
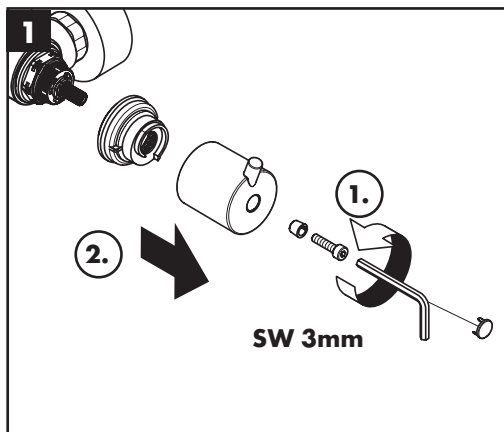

max.
≈ 42° C

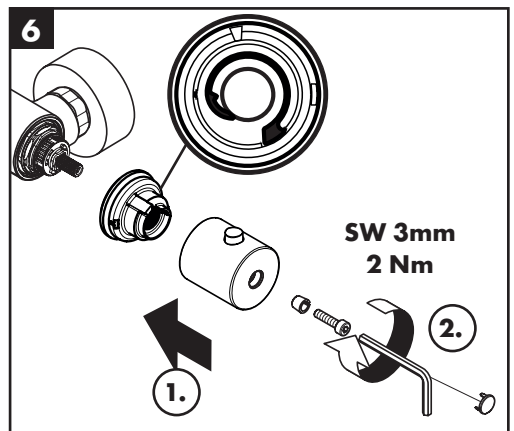
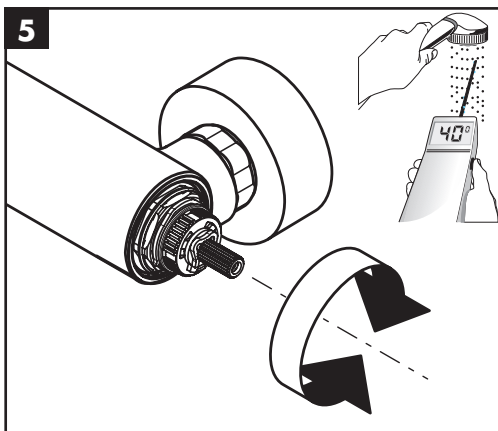
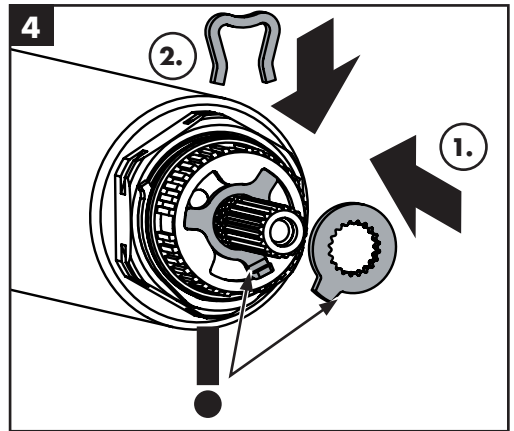
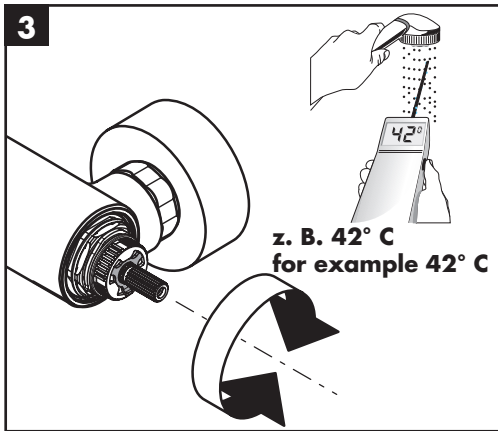
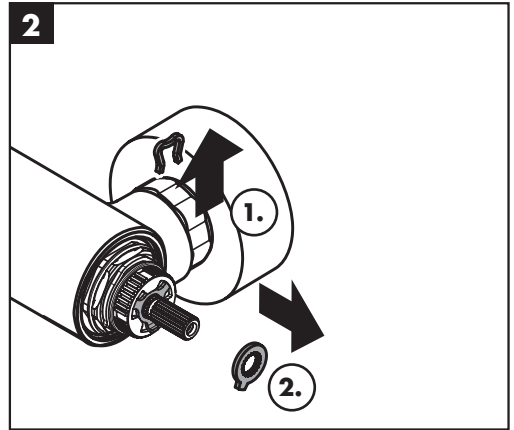
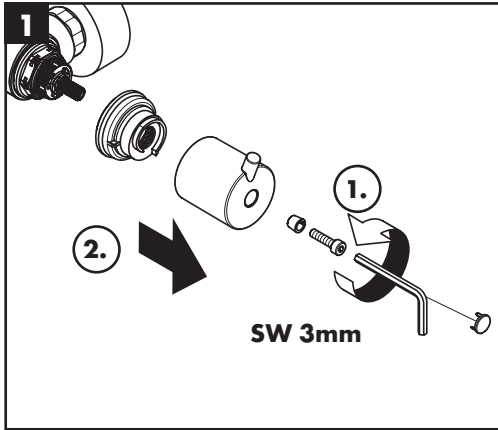



Raindance Showerpipe 27218000

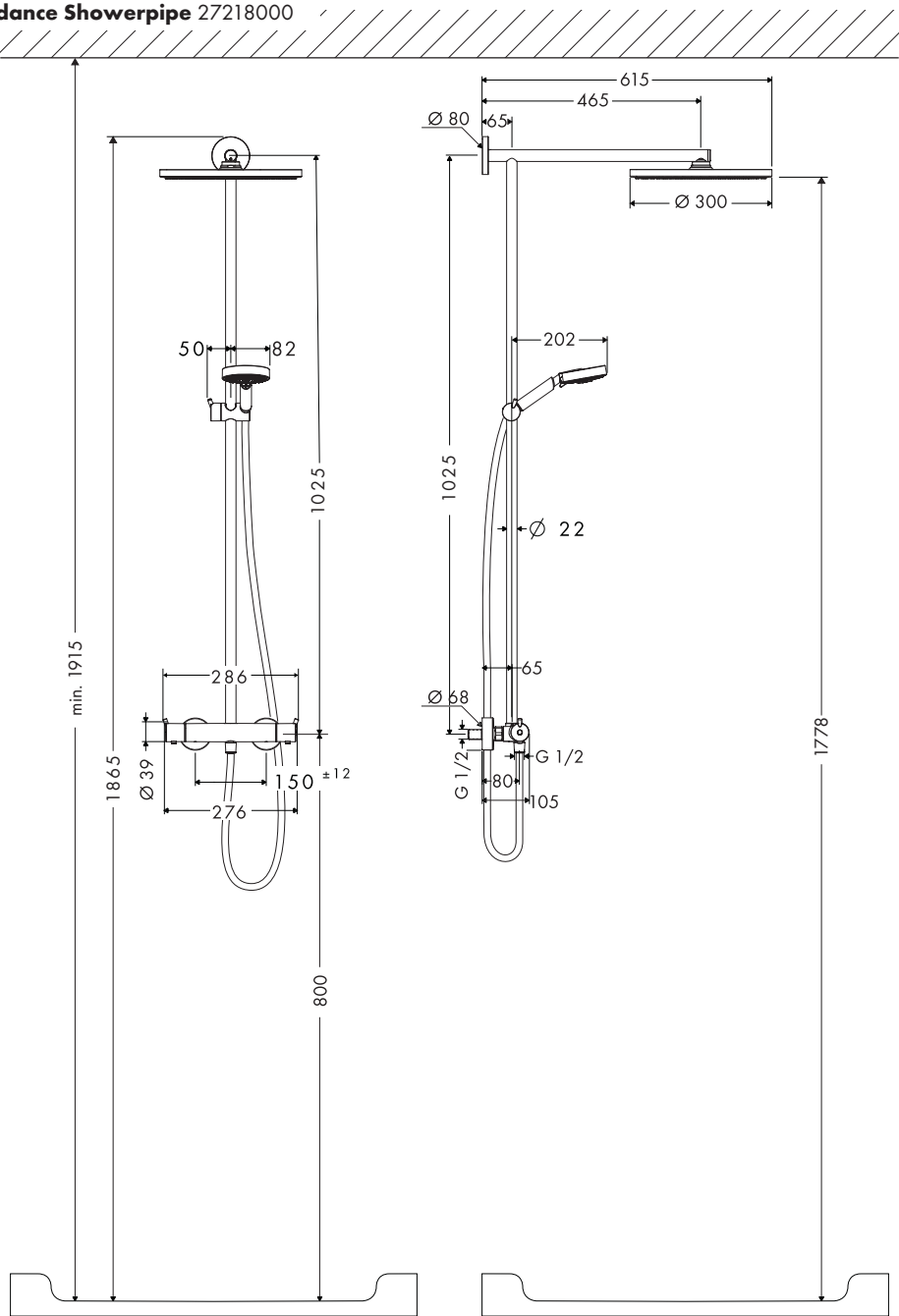



Raindance Showerpipe

27218000

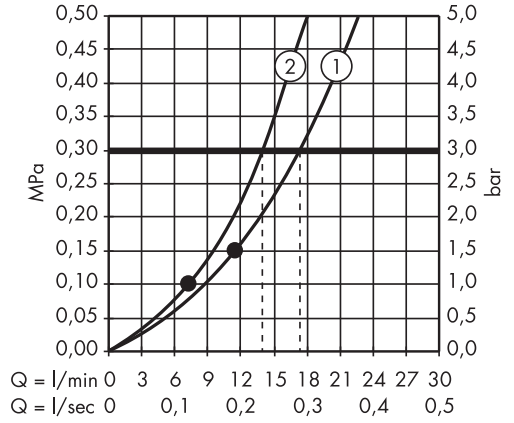
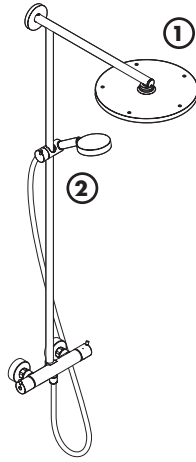

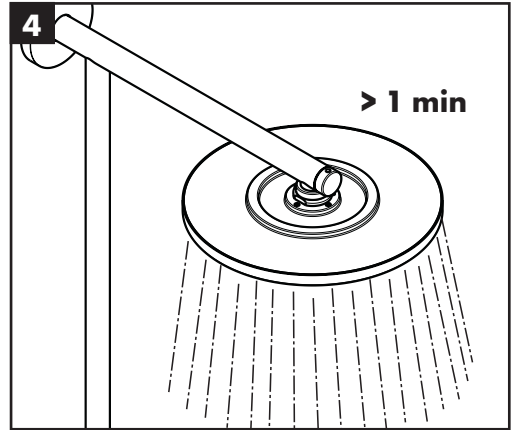
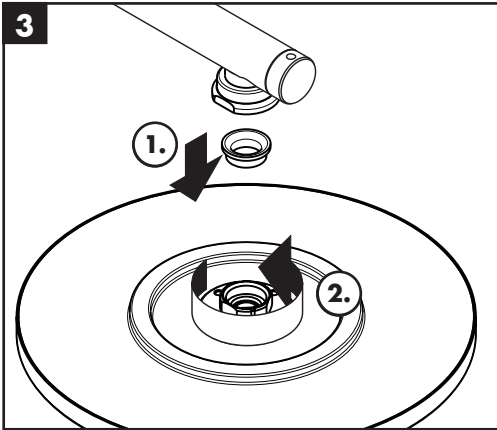
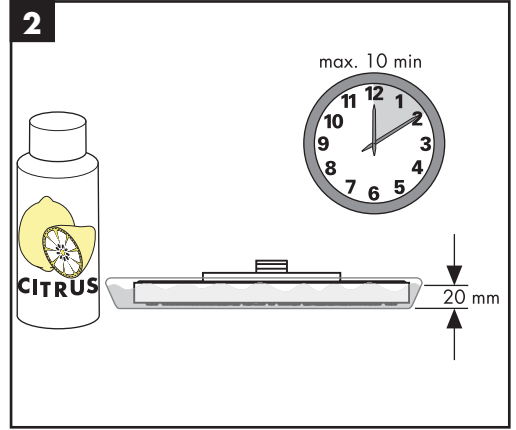
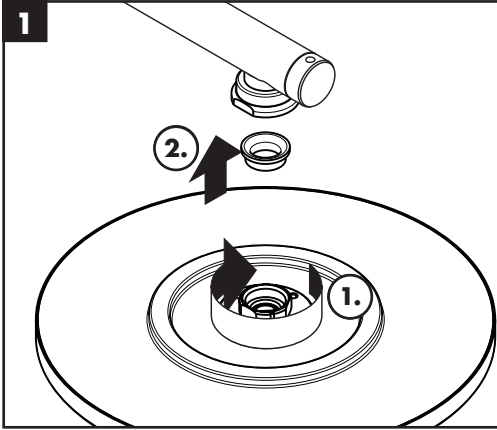

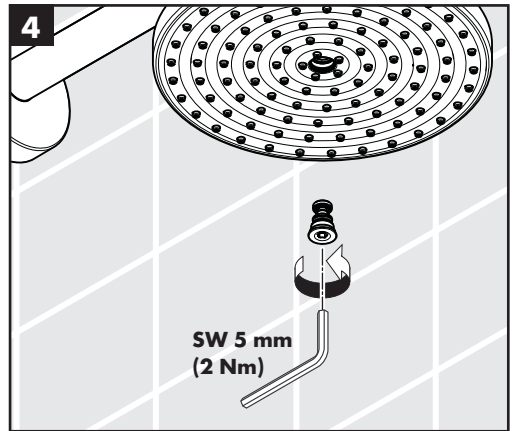
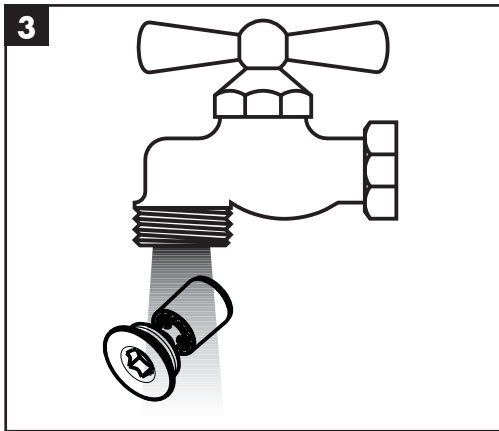
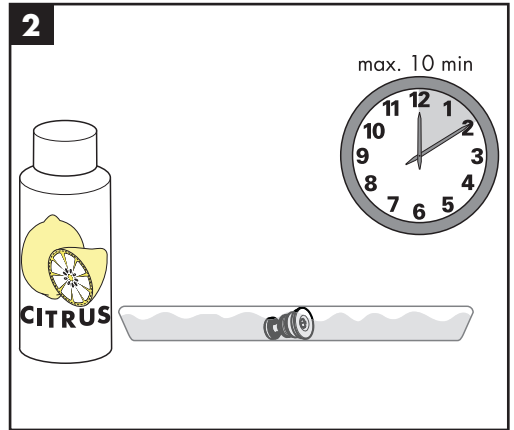
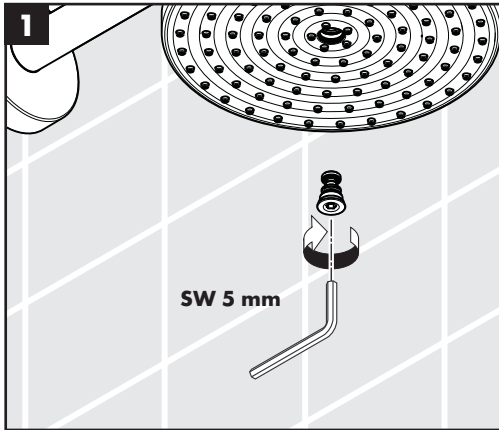

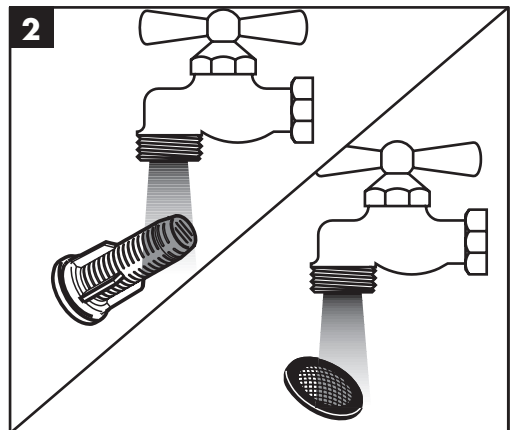
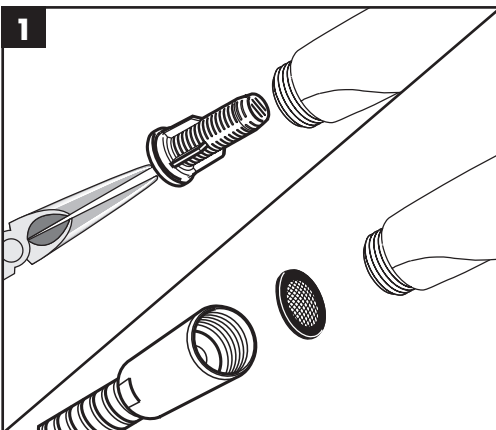
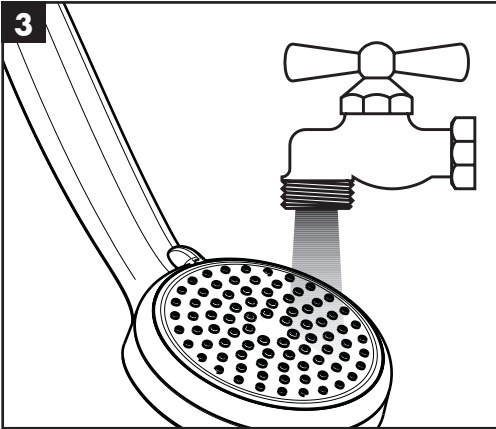
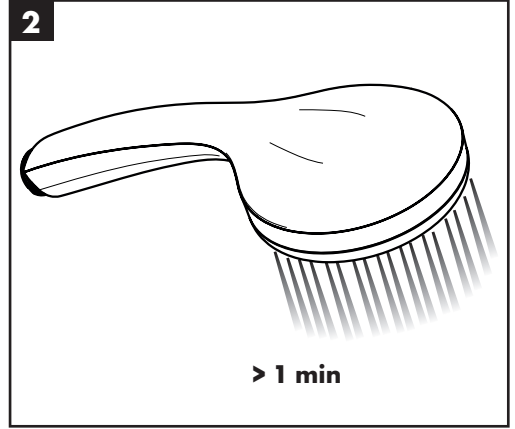
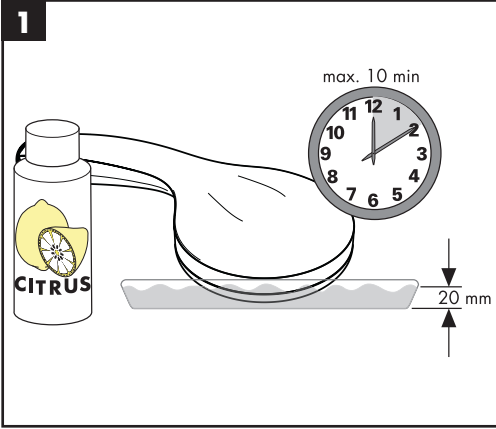

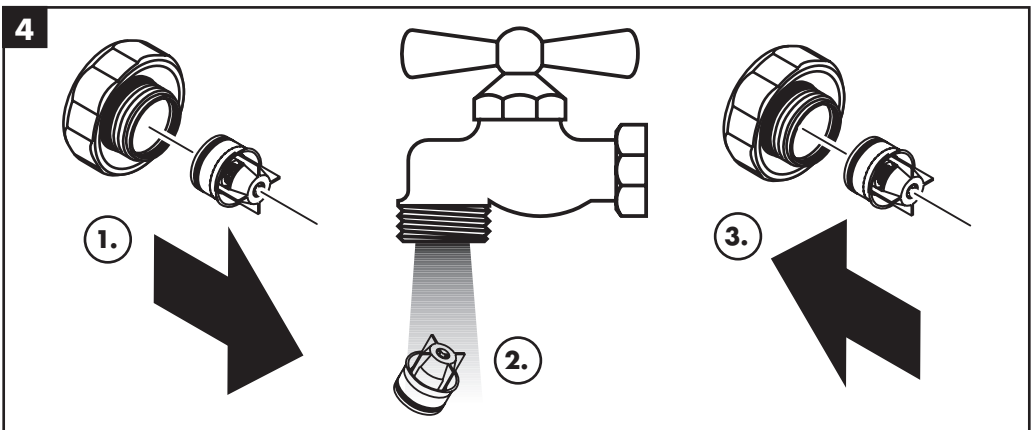
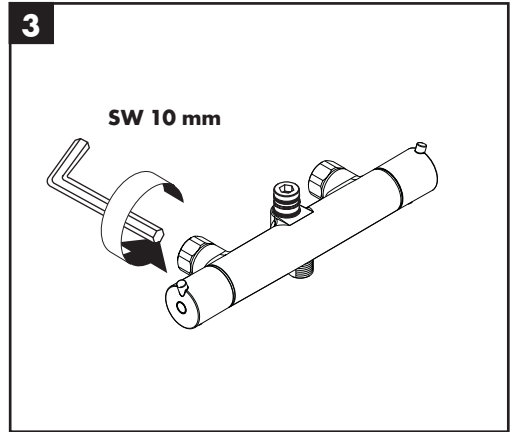
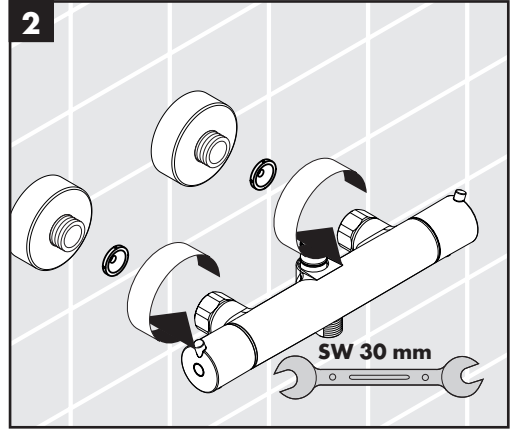
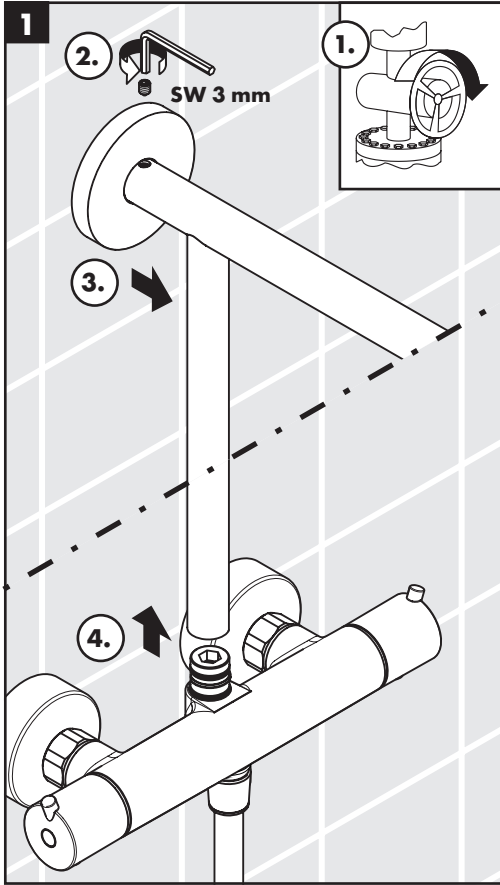

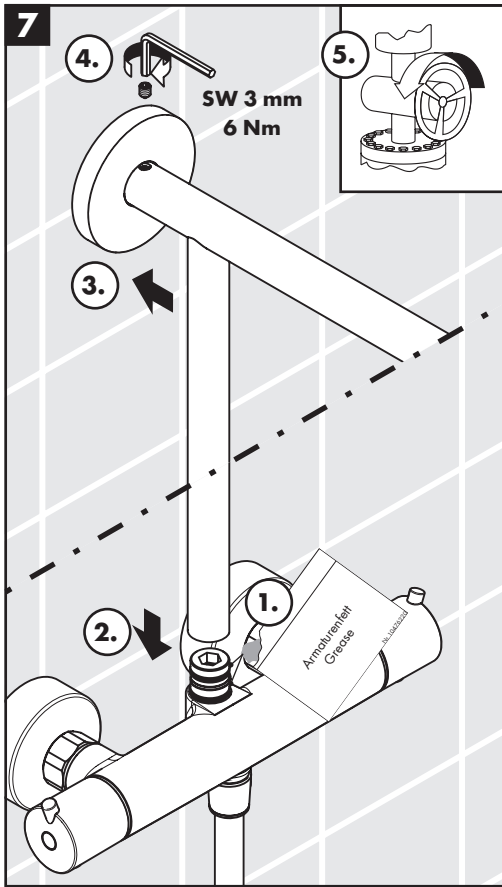
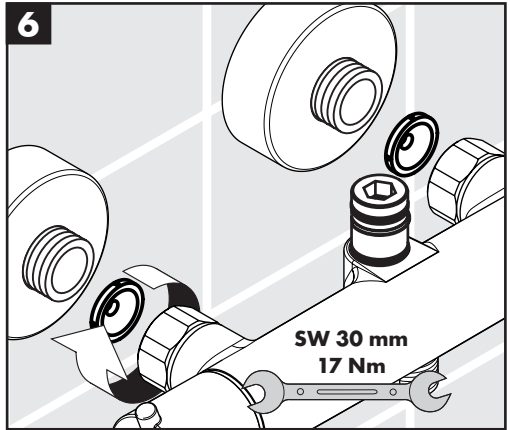
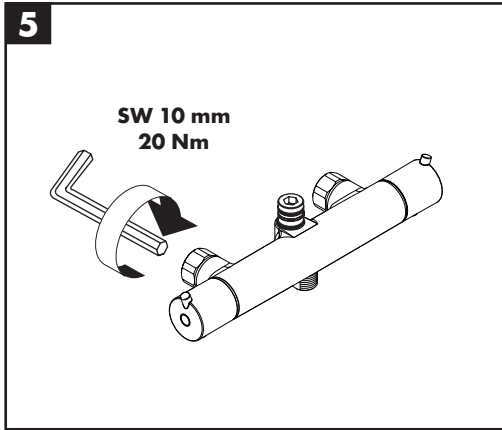

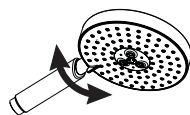
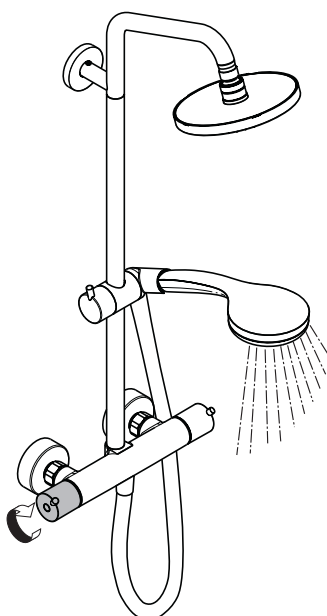
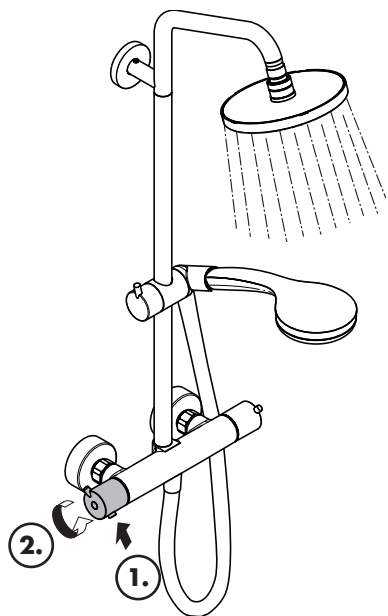

- 1  Balance AIR
- 2  Rain AIR
- 3  Whirl AIR

öffnen / ouvert / open / aperto / abierto / open / åbne / abrir / otworzyć / otevřít / otvorit / 开 / открыть / nyitás /
avaaminen / öppna / atidaryti / Otvaranje / açmak / deschide / ανοικτό / odpreti / avage / atvērt / otvoriti / åpne /
отваряне / hare / حتف

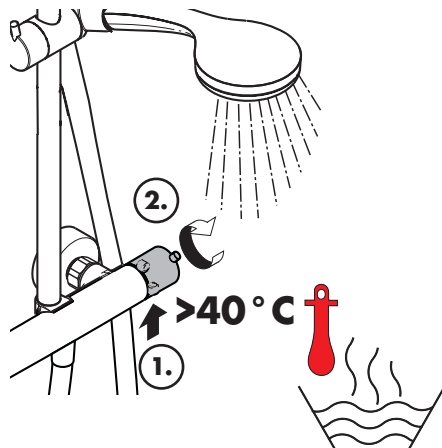
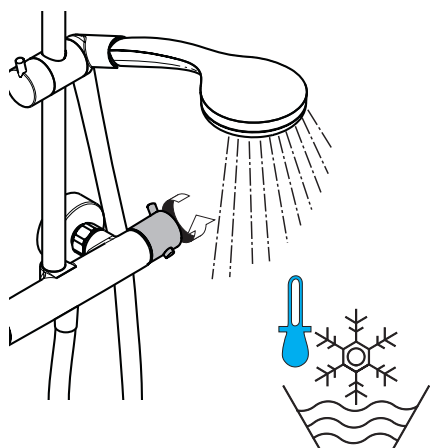

kalt / froid / cold / freddo / frío / koud / koldt / fria /
zimna / studená / studená / 冷 / холодная / hideg /
kylmä / kallt / šaltas / Hladno / soğuk / rece / krúo /
mrzlo / külm / auksts / hladno / kaldt / студено / i fhohtë /
دراب

warm / chaud / hot / caldo / caliente / warm / varmt /
quente / ciepła / teplá / teplá / 热 / горячая / meleg /
lämmin / varmt / karštas / Vruća voda / sıcak / cald /
ζεστό / toplo / kuum / karsts / topla / varm / тепло /
i ngrohtë / ن خ ل س

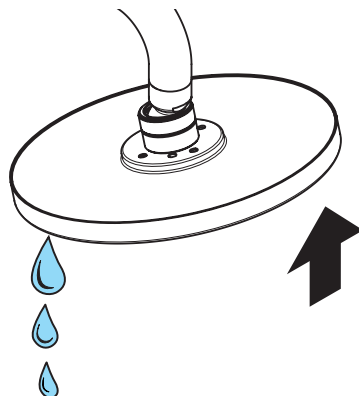
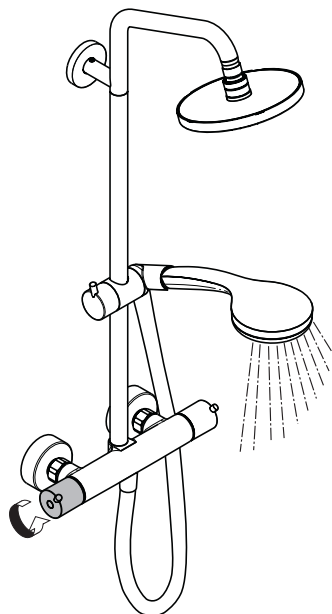

schließen / fermé / close / chiudere / cerrar /
sluiten / lukke / fechar / zamknąć / zavřít / uzavrieť /
关 / закрыть / bezárás / sulkeminen / stänga / uždaryti /
Zatvaranje / kapatmak / închide / κλειστό / zapreti /
sulgege / aizvērt / zatvori / lukke / затваряне / тбылге /
قالغ

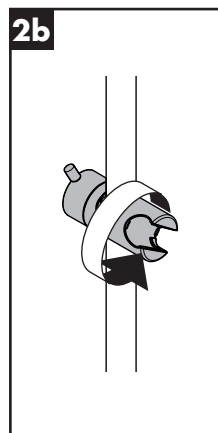
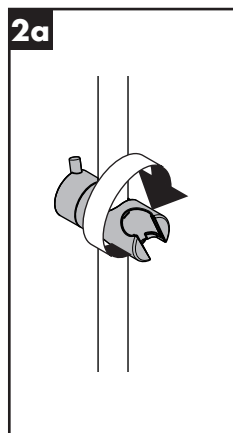
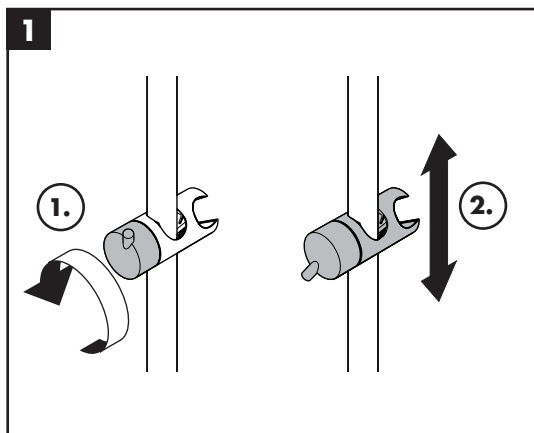



Raindance Showerpipe
27218000

