

DE	Gebrauchsanleitung / Montageanleitung	2
FR	Mode d'emploi / Instructions de montage	3
EN	Instructions for use / assembly instructions	4
IT	Istruzioni per l'uso / Istruzioni per Installazione	5
ES	Modo de empleo / Instrucciones de montaje	6

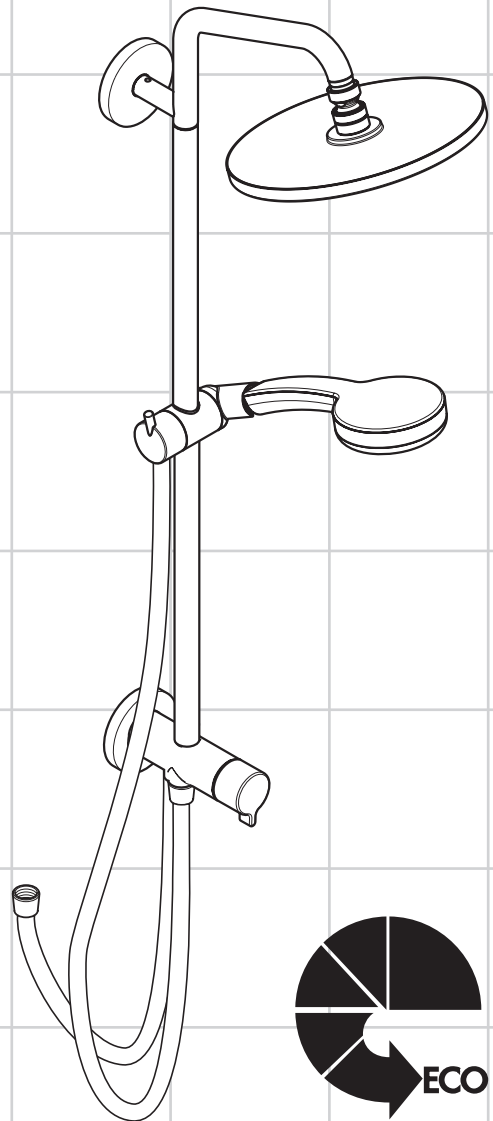

Showerpipe 240 Reno EcoSmart
27137000





Sicherheitshinweise

- ⚠ Bei der Montage müssen zur Vermeidung von Quetsch- und Schnittverletzungen Handschuhe getragen werden.
- ⚠ Das Produkt darf nur zu Bade-, Hygiene- und Körperreinigungszwecken eingesetzt werden.
- ⚠ Der Kopfbrausearm ist nur für das Halten der Kopfbrause ausgelegt, er darf nicht mit weiteren Gegenständen belastet werden!
- ⚠ Kinder, sowie Erwachsene mit körperlichen, geistigen und / oder sensorischen Einschränkungen dürfen das Produkt nicht unbeaufsichtigt benutzen. Personen, die unter Alkohol- oder Drogeneinfluss stehen, dürfen das Produkt nicht benutzen.
- ⚠ Der Kontakt der Brausestrahlen mit empfindlichen Körperstellen (z. B. Augen) muss vermieden werden. Es muss ein ausreichender Abstand zwischen Brause und Körper eingehalten werden.
- ⚠ Das Produkt darf nicht als Haltegriff benutzt werden. Es muss ein separater Haltegriff montiert werden.
- ⚠ Große Druckunterschiede zwischen den Kalt- und Warmwasseranschlüssen müssen ausgeglichen werden.

Montagehinweise

- Vor der Montage muss das Produkt auf Transportschäden untersucht werden. Nach dem Einbau werden keine Transport- oder Oberflächenschäden anerkannt.
- Die Leitungen und die Armatur müssen nach den gültigen Normen montiert, gespült und geprüft werden.
- Die in den Ländern jeweils gültigen Installationsrichtlinien sind einzuhalten.
- Die in der Montageanleitung angegebenen Montagemaße sind ideal für Personen von ca. 1800 mm Körpergröße und müssen gegebenenfalls angepasst werden. Hierbei ist darauf zu achten, dass sich bei geänderter Montagehöhe die Mindesthöhe ändert und die Änderung der Anschlussmaße berücksichtigt werden müssen.
- Bei der Montage des Produktes durch qualifiziertes Fachpersonal ist darauf zu achten, dass die Befestigungsfläche im gesamten Bereich der Befestigung plan ist (keine vorstehenden Fugen oder Fliesenversatz), der Wandaufbau für eine Montage des Produktes geeignet ist und keine Schwachstellen aufweist.
- Die der Brause beigepackte Siebdichtung muss eingebaut werden, um Schmutzeinspülungen aus dem Leitungsnetz zu vermeiden. Schmutzeinspülungen können die Funktion beeinträchtigen und/oder zu Beschädigungen an Funktionsteilen der Brause führen, für hieraus ergebende Schäden haftet Hansgrohe nicht.
- Die Brause darf nur nach einem Absperrventil oder einer Sanitärarmatur angeschlossen werden.
- Im Notfall kann das Rohr zwischen Armatur und Kopfbrause im unteren Bereich mit einer feinen Säge gekürzt werden.

Technische Daten

Betriebsdruck: max. 1 MPa
 Empfohlener Betriebsdruck: 0,17 - 0,4 MPa
 (1 MPa = 10 bar = 147 PSI)
 Heißwassertemperatur: max. 60°C
 Thermische Desinfektion: max. 70°C / 4 min

Eigensicher gegen Rückfließen
 Das Produkt ist ausschließlich für Trinkwasser konzipiert!

Symbolerklärung

 Kein essigsäurehaltiges Silikon verwenden!

 **Wartung** (siehe Seite 10)

Rückflussverhinderer müssen gemäß DIN EN 1717 regelmäßig in Übereinstimmung mit nationalen oder regionalen Bestimmungen auf ihre Funktion geprüft werden (mindestens einmal jährlich).

 **Maße** (siehe Seite 11)

 **Durchflussdiagramm** (siehe Seite 11)

① Handbrause
 ② Kopfbrause

 **Bedienung** (siehe Seite 10)

Zum Entleeren der Kopfbrause diese nach dem Benutzen leicht schräg stellen.

 **Reinigung** (siehe Seite 12) und beiliegende Broschüre

 **Serviceteile** (siehe Seite 7)

Sonderzubehör (nicht im Lieferumfang enthalten)

 Fliesenausgleichsscheibe chrom #98681000 (siehe Seite 7)

 **Prüfzeichen** (siehe Seite 16)





Consignes de sécurité

- ⚠ Lors du montage, porter des gants de protection pour éviter toute blessure par écrasement ou coupure.
- ⚠ Le produit ne doit servir qu'à se laver et à assurer l'hygiène corporelle.
- ⚠ Le bras de la douchette n'est conçu que pour tenir la douchette et ne doit pas servir à la suspension d'autres objets !
- ⚠ Il est interdit aux enfants ainsi qu'aux adultes ayant des insuffisances physiques, psychiques et/ou motrices d'utiliser la douche sans surveillance. De même, il est interdit à des personnes sous influence d'alcool ou de drogues d'utiliser la douche.
- ⚠ Éviter le contact du jet de la douchette avec les parties sensibles du corps (telles par ex. que les yeux). Veiller à respecter un écart suffisant entre la douchette et le corps
- ⚠ Le produit ne doit pas servir de poignée. Monter pour cela une poignée séparée.
- ⚠ Il est conseillé d'équilibrer les pressions de l'eau chaude et froide.

Instructions pour le montage

- Avant son montage, s'assurer que le produit n'a subi aucun dommage pendant le transport. Après le montage, tout dommage de transport ou de surface ne pourra pas être reconnu.
- Les conduites et la robinetterie doivent être montés, rincés et contrôlés selon les normes en vigueur.
- Les directives d'installation en vigueur dans le pays concerné doivent être respectées.
- Les dimensions d'installation indiquées dans la notice de montage sont idéales pour des personnes d'une taille de 1800 mm environ et doivent être ajustées selon le cas. Tenir compte pour cela du fait qu'un changement de hauteur modifie la hauteur minimum et que la modification des cotes de raccord doit entrer en ligne de compte.
- Lors du montage de ce produit par du personnel qualifié, veiller à ce que la surface de fixation soit bien plane dans toute la zone de fixation (pas de dépassement de joints ou de déport de carreaux), à ce que le mur se prête au montage du produit et ne présente aucun point fragile.
- Le joint à filtre fourni avec la pomme de douche à main doit être installé afin de retenir des impuretés du système de conduites. Ceux-ci pourraient influencer le fonctionnement de ce produit et même endommager des pièces mobiles. Des réclamations à la suite de l'usage de la pomme de douche sans joint-tamis de hansgrohe ne peuvent pas faire partie de notre garantie.
- La douchette ne doit être raccordée qu'en aval d'une vanne d'arrêt ou d'une robinetterie sanitaire.
- En cas d'urgence, il est possible de raccourcir, dans la partie inférieure, le tuyau reliant la robinetterie au pommeau de la douche à l'aide d'une scie fine.

Informations techniques

Pression de service autorisée: max. 1 MPa
 Pression de service conseillée: 0,17 - 0,4 MPa
 (1 MPa = 10 bar = 147 PSI)
 Température d'eau chaude: max. 60°C
 Désinfection thermique: max. 70°C / 4 min

Avec dispositif anti-retour

Le produit est exclusivement conçu pour de l'eau potable!

Description du symbole



Ne pas utiliser de silicone contenant de l'acide acétique!



Entretien (voir pages 10)

Les clapets anti-retour doivent être examinés régulièrement conformément à la norme EN 1717 ou conformément aux dispositions nationales ou régionales quant à leur fonction (au moins une fois par an).



Dimensions (voir pages 11)



Diagramme du débit (voir pages 11)

- ① Douchette
- ② pomme de douche



Instructions de service (voir pages 10)

Pour vider le pommeau de la douchette, l'incliner légèrement après l'utilisation.



Nettoyage (voir pages 12) et brochure ci-jointe



Pièces détachées (voir pages 7)

Accessoires en option (ne fait pas partie de la fourniture)

cale de compensation chromé #98681000 (voir pages 7)









Classification acoustique et débit (voir pages 16)





Safety Notes

-  Gloves should be worn during installation to prevent crushing and cutting injuries.
-  The product may only be used for bathing, hygienic and body cleaning purposes.
-  The arm of the shower head is intended only to hold the shower head. Do not load it down with other objects!
-  Children as well as adults with physical, mental and/or sensoric impairments must not use this product without proper supervision. Persons under the influence of alcohol or drugs are prohibited from using this product.
-  Do not allow the streams of the shower touch sensitive body parts (such as your eyes). An adequate distance must be kept between the shower and you.
-  The product may not be used as a holding handle. A separate handle must be installed.
-  The hot and cold supplies must be of equal pressures.

Installation Instructions

- Prior to installation, inspect the product for transport damages. After it has been installed, no transport or surface damage will be honoured.
- The pipes and the fixture must be installed, flushed and tested as per the applicable standards.
- The plumbing codes applicable in the respective countries must be observed.
- The installation dimensions stated in these installation instructions are ideal for people of approximately 1800 mm in body height. The dimensions can be altered if required. In this case, pay attention to the fact that a change of installation height will also change the minimum height, and that the altered mounting dimensions must be taken into consideration.
- During installation of the product by qualified trained personnel, make sure that the entire fastening surface is even and smooth (no protruding seams or tile offset), that the finish of the wall is suitable to apply the product and has no weak points.
- The mesh washer must be insert to protect the shower against incoming dirt by pipework. Incoming dirt leads to defects or/and can damage parts of the shower; such caused faults voids all liability and guarantee claims.
- The shower may only be connected downstream of a shut-off valve or sanitary fitting.
- If required, the bottom part of the pipe between the fixture and the shower head can be shortened with a fine-toothed saw.

Technical Data

Operating pressure: max. 1 MPa
 Recommended operating pressure: 0,17 - 0,4 MPa
 (1 MPa = 10 bar = 147 PSI)
 Hot water temperature: max. 60°C
 Thermal disinfection: max. 70°C / 4 min

Safety against backflow
 The product is exclusively designed for drinking water!

Symbol description



Do not use silicone containing acetic acid!

Maintenance (see page 10)

The check valves must be checked regularly according to DIN EN 1717 in accordance with national or regional regulations (at least once a year).

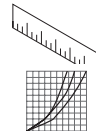

Dimensions (see page 11)

Flow diagram (see page 11)

- ① Hand shower
- ② overhead shower



Operation (see page 10)

To empty the overhead shower after use, hold it in a slightly inclined position.



Cleaning (see page 12) and enclosed brochure



Spare parts (see page 7)

Special accessories (order as an extra)



tile-matching-disk chrome plated #98681000 (see page 7)



Test certificate (see page 16)





Indicazioni sulla sicurezza

- ⚠ Durante il montaggio, per evitare ferite da schiacciamento e da taglio bisogna indossare guanti protettivi.
- ⚠ Il prodotto deve essere utilizzato esclusivamente per fare il bagno e per l'igiene del corpo.
- ⚠ Il braccio del soffione della doccia è progettato per sostenere solo quest'ultimo, non va sovraccaricato con altri oggetti!
- ⚠ I bambini e gli adulti affetti da menomazioni fisiche, psichiche e/o sensoriali devono utilizzare il sistema doccia solo sotto sorveglianza. Il prodotto non deve essere utilizzato da persone sotto l'effetto di droghe o alcolici.
- ⚠ Bisogna evitare il contatto fra il getto della doccia e parti del corpo delicate (ad es. gli occhi). Fra il soffione ed il corpo va mantenuta una distanza sufficiente.
- ⚠ Il prodotto non deve essere utilizzato come maniglia, questa deve essere montata separatamente.
- ⚠ Attenzione! Compensare le differenze di pressione tra i collegamenti dell'acqua fredda e dell'acqua calda.

Istruzioni per il montaggio

- Prima del montaggio è necessario controllare che non ci siano stati danni durante il trasporto. Una volta eseguito il montaggio, non verranno riconosciuti eventuali danni di trasporto o delle superfici.
- Montare, lavare e controllare tubature e rubinetteria rispettando le norme correnti.
- Vanno rispettate le direttive di installazione nazionali vigenti nel rispettivo paese.
- Le quote di montaggio indicate nelle istruzioni di montaggio sono ideali per persone grandi circa 1800 mm e eventualmente vanno adattate. A ciò bisogna fare attenzione, che ad altezza di montaggio cambiata l'altezza minima necessaria indicata cambia e che bisogna considerare la modifica delle quote di collegamento.
- Per il montaggio del prodotto da personale specializzato qualificato bisogna fare attenzione, che la superficie di fissaggio, in tutto il campo di fissaggio, sia piana (nessuna giunzione sporgente o sfalsamento di piastrella), la costruzione della parete sia adatta al montaggio del prodotto e che non presenti alcun punto debole.
- Per proteggere la soffione doccia da eventuali impurità provenienti dalle tubazioni dell'acqua, deve essere inserito il filtro nell'impugnatura della doccia stessa. Tali impurità possono infatti causare difetti e/o danneggiare parti della doccia; in questo caso la Hansgrohe non risponde dei danni.
- La doccia deve essere collegata solo a valle di una valvola d'arresto o di un'armatura sanitaria.
- Se necessario il tubo può essere accorciato tra il raccordo e la doccetta nella parte inferiore usando un seghetto.

Dati tecnici

Pressione d'uso: max. 1 MPa
 Pressione d'uso consigliata: 0,17 - 0,4 MPa
 (1 MPa = 10 bar = 147 PSI)
 Temperatura dell'acqua calda: max. 60°C
 Disinfezione termica: max. 70°C / 4 min

Sicurezza antiriflusso
 Il prodotto è concepito esclusivamente per acqua potabile!

Descrizione simbolo



Non utilizzare silicone contenente acido acetico!

Manutenzione (vedi pagg. 10)

La valvola di non ritorno deve essere controllata regolarmente come da DIN EN 1717, secondo le normative nazionali e regionali (almeno una volta all'anno).

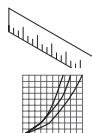

Ingombri (vedi pagg. 11)

Diagramma flusso (vedi pagg. 11)

- ① Doccetta
- ② soffione doccia



Procedura (vedi pagg. 10)

Per svuotare la doccia di testa dopo averla usata, posizionarla leggermente obliqua.



Pulitura (vedi pagg. 12) e brochure allegata



Parti di ricambio (vedi pagg. 7)

Accessori speciali (non contenuto nel volume di fornitura)

distanziali da piastrella cromato #98681000 (vedi pagg. 7)



Segno di verifica (vedi pagg. 16)





Indicaciones de seguridad

- ⚠ Durante el montaje deben utilizarse guantes para evitar heridas por aplastamiento o corte.
- ⚠ El producto solo debe ser utilizado para fines de baño, higiene y limpieza corporal.
- ⚠ El brazo del pulverizador de ducha solo está previsto para soportar el pulverizador de ducha y no debe cargarse con otros objetos!
- ⚠ Niños, así como adultos con limitaciones corporales, mentales y/o sensoriales no deben utilizar el sistema de duchas sin vigilancia. Personas que se encuentran bajo el efecto de alcohol o drogas, no deben utilizar el sistema de duchas.
- ⚠ Debe evitarse el contacto del chorro del pulverizador con partes sensibles del cuerpo (por ej. ojos). Debe mantenerse una distancia suficiente entre pulverizador y cuerpo.
- ⚠ El producto no debe ser utilizado como un elemento de sujeción. Debe montarse un elemento de sujeción separado.
- ⚠ Grandes diferencias de presión en servicio entre agua fría y agua caliente deben equilibrarse.

Indicaciones para el montaje

- Antes del montaje se debe examinar el producto contra daños de transporte. Después de la instalación no se reconoce ningún daño de transporte o de superficie.
- Los conductos y la grifería deben montarse, lavarse y comprobarse según las normas vigentes.
- Es obligatorio el cumplimiento de las directrices de instalación vigentes en el país respectivo.
- Las medidas indicadas en las instrucciones de montaje resultan ideales para personas de 1800 mm de altura, por lo que deberán ajustarse siempre que sea necesario. En este sentido, es importante tener en cuenta que, en caso de modificación de la altura de montaje, cambia la altura mínima y habrá que adaptar las medidas de conexión.
- Durante el montaje del producto, mediante personal especializado, se debe asegurar de que la superficie de sujeción en todo el área de la fijación sea plana (sin fugas o azulejos que sobresalgan), que la estructura del muro sea adecuada para el montaje del producto y que no presente puntos débiles.
- La junta de filtración que se suministra con la ducha mural evita que las partículas de suciedad procedentes de las tuberías lleguen a la ducha mural. Debe colocarse entre el flexo y la ducha mural. Infiltraciones de suciedad deterioran el funcionamiento de la ducha mural y pueden causar daños en el interior de la misma que no están cubiertas por la garantía de Hansgrohe.
- La roseta de ducha debe conectarse siempre a una válvula de bloqueo o a valvulería sanitaria.
- En caso de necesidad, con una sierra fina puede recortarse por la parte de abajo el tubo entre el grifo y la ducha.

Datos técnicos

Presión en servicio:	max. 1 MPa
Presión recomendada en servicio: (1 MPa = 10 bar = 147 PSI)	0,17 - 0,4 MPa
Temperatura del agua caliente:	max. 60°C
Desinfección térmica:	max. 70°C / 4 min

Seguro contra el retorno

El producto ha sido concebido exclusivamente para agua potable.

Descripción de símbolos



No utilizar silicona que contiene ácido acético!

Mantenimiento (ver página 10)

Las válvulas anti-retorno tienen que ser controladas regularmente según la norma DIN EN 1717, en acuerdo con las regulaciones nacionales o regionales (una vez al año, por lo menos).



Dimensiones (ver página 11)



Diagrama de circulación (ver página 11)

- ① Teleducha
- ② Ducha fija



Manejo (ver página 10)

Para vaciar la ducha, colóquela en una posición ligeramente inclinada tras el uso.



Limpiar (ver página 12) y folleto anexo



Repuestos (ver página 7)

Opcional (no incluido en el suministro)



Pieza desuplemento cromado #98681000 (ver página 7)



Marca de verificación (ver página 16)



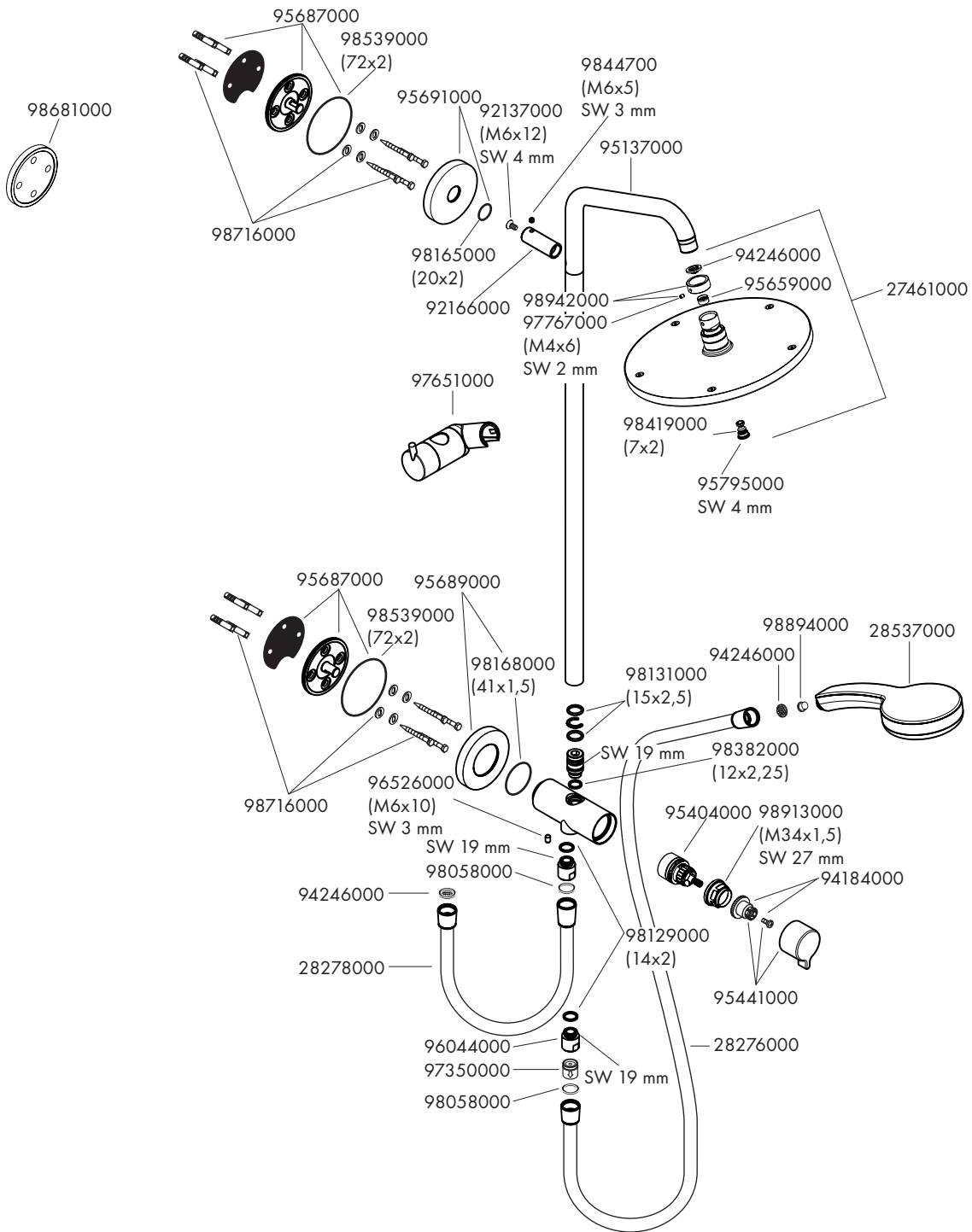

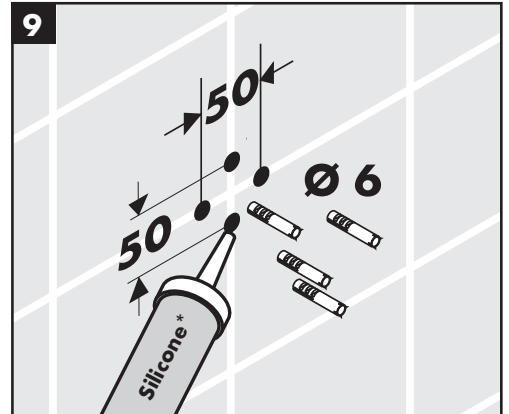
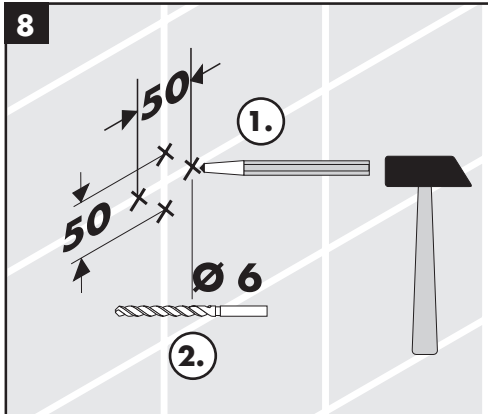
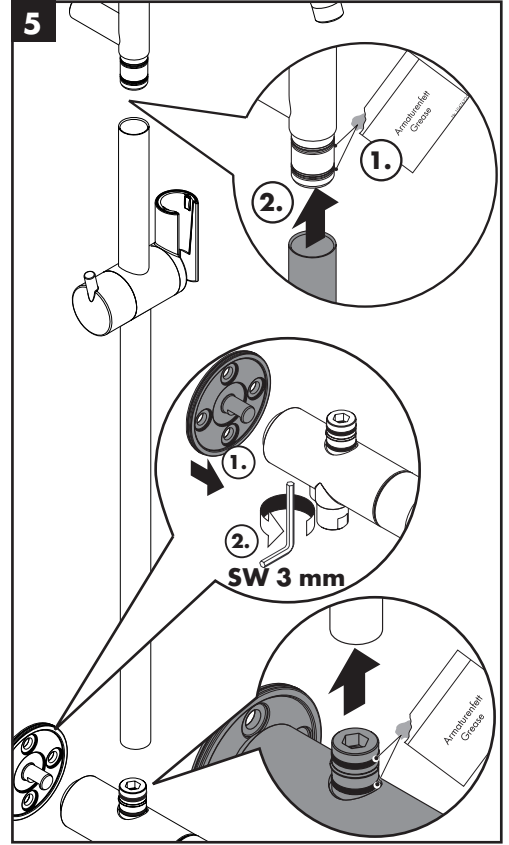
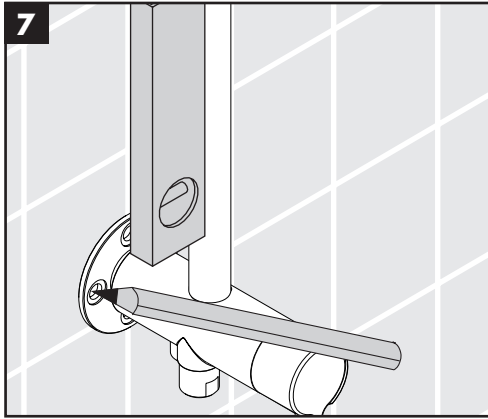
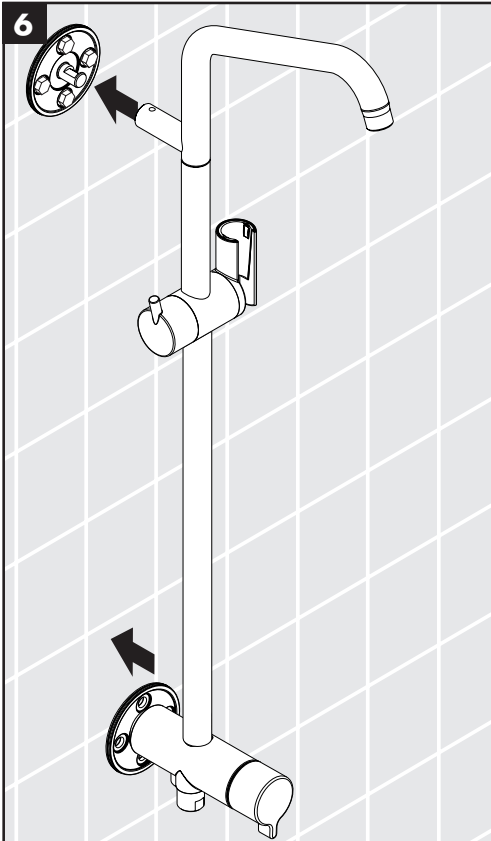
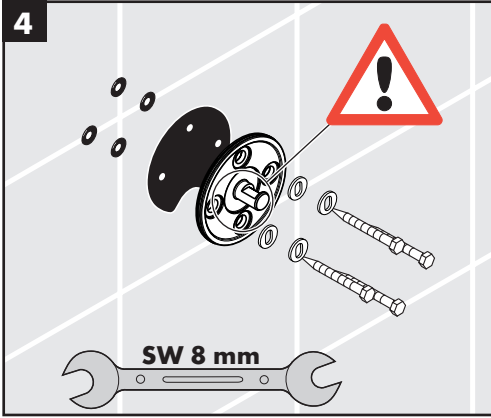
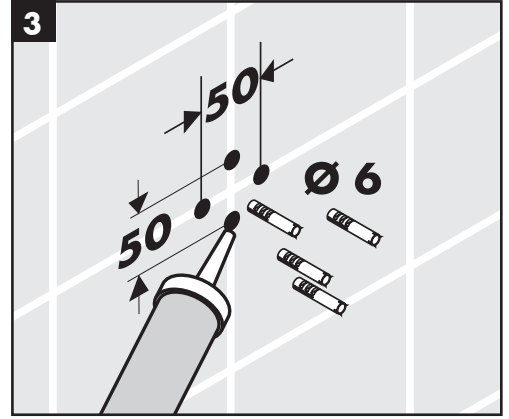
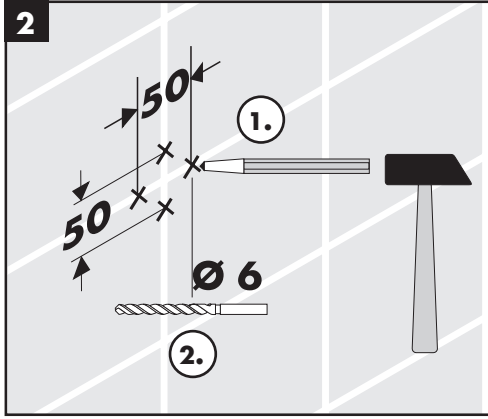
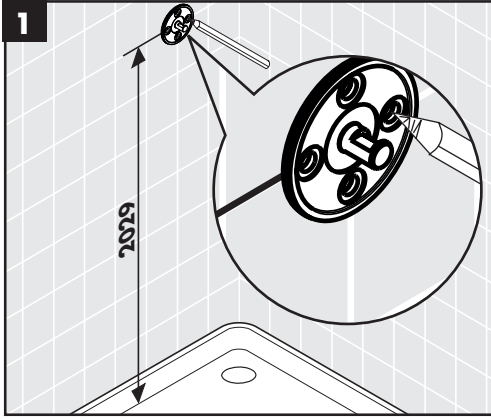

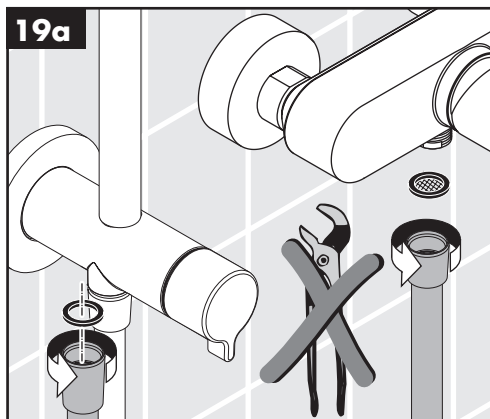
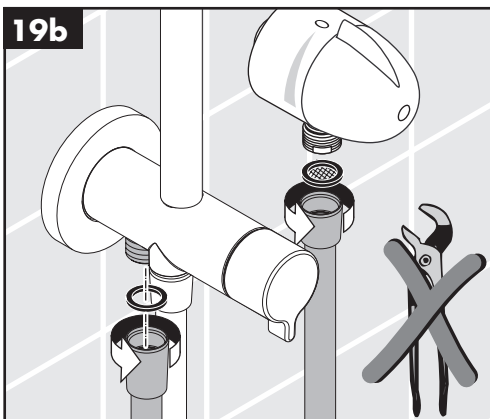
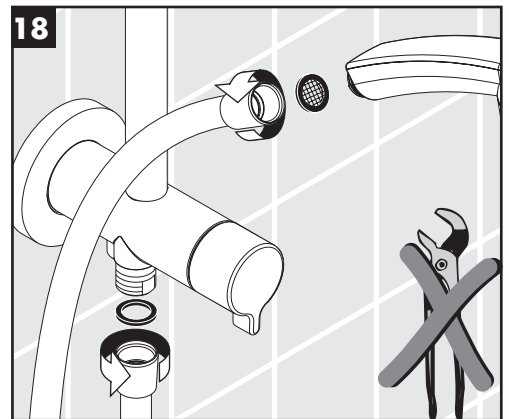
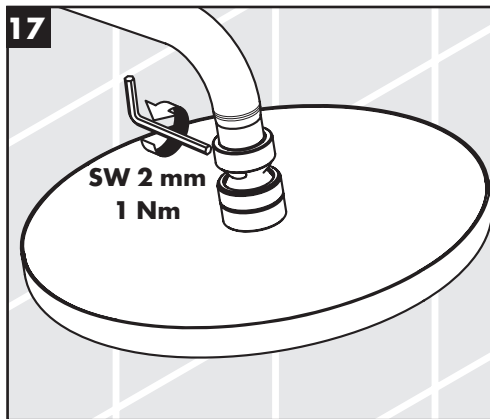
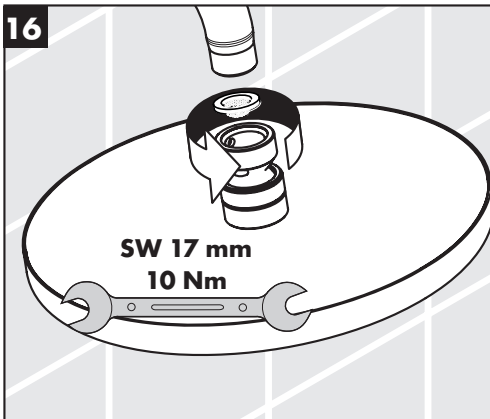
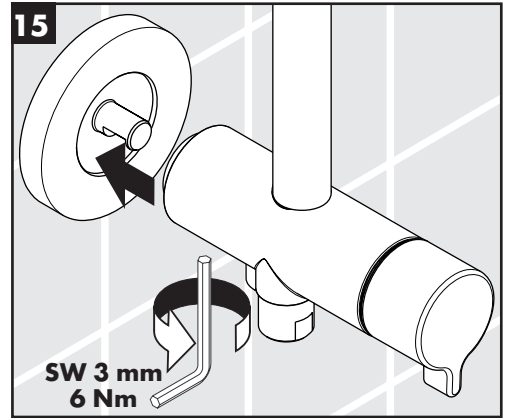
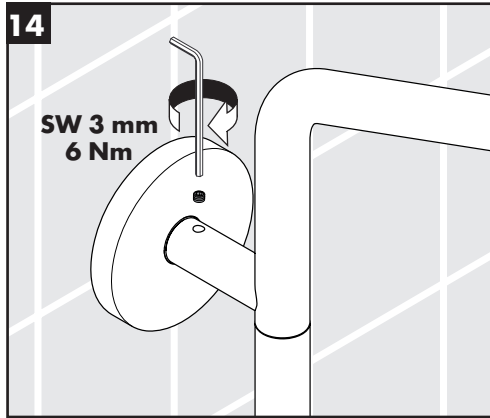
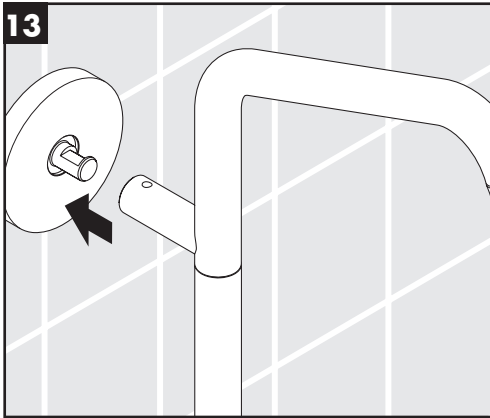
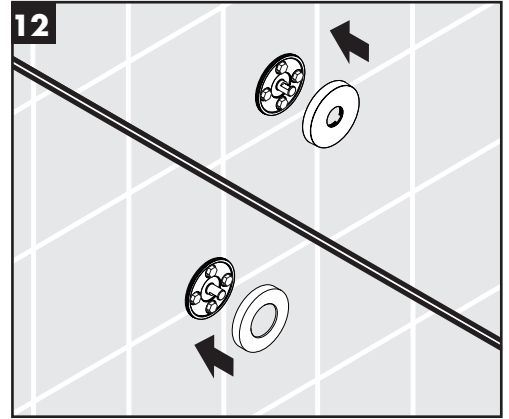
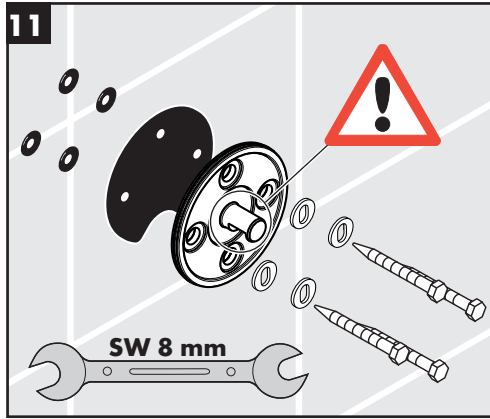
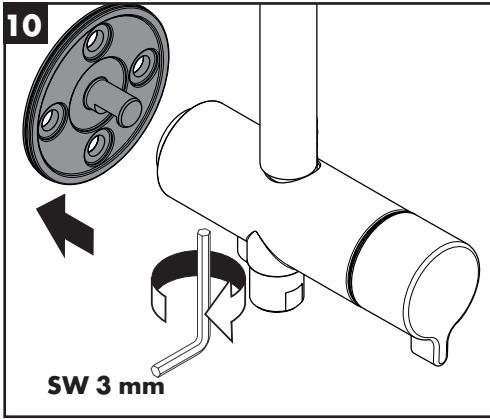

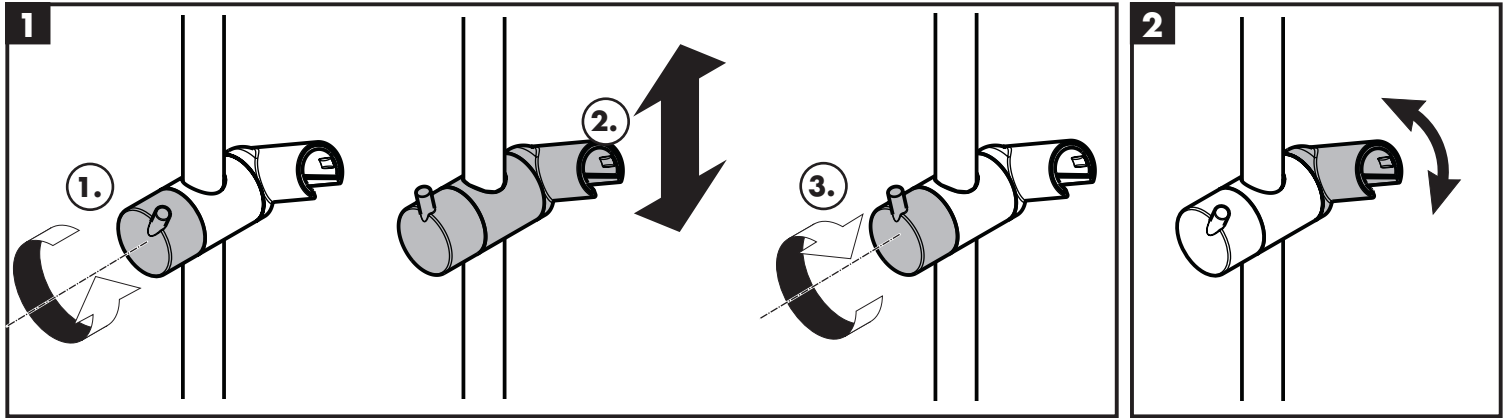
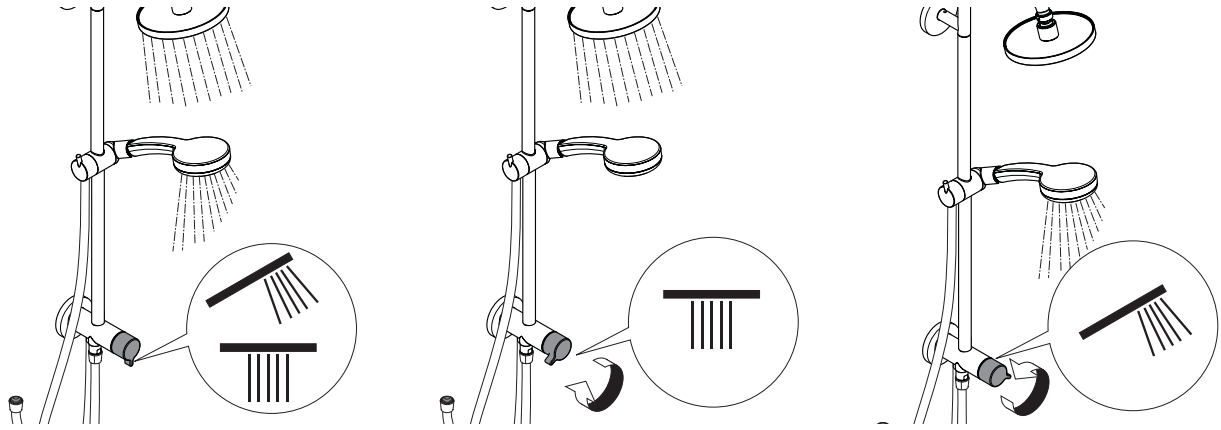

Croma 100 Vario 28537000

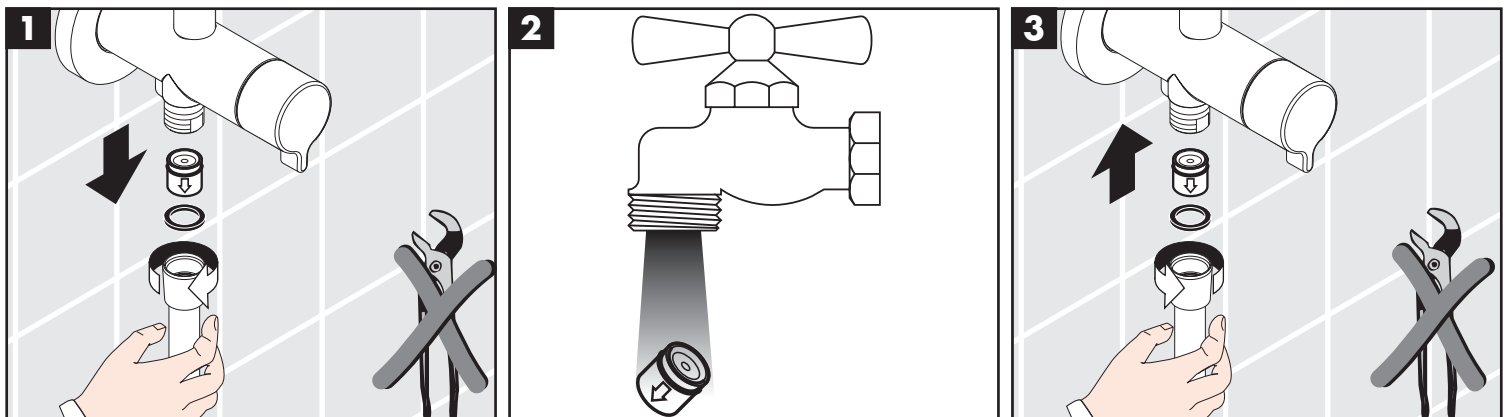
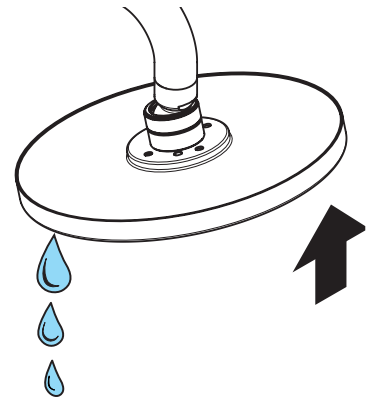
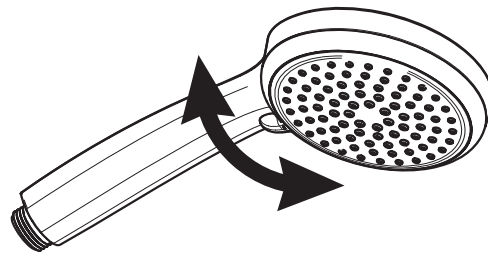
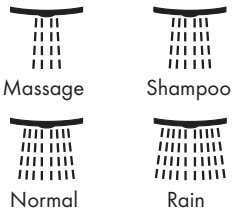



Showerpipe 240 Reno EcoSmart

27137000

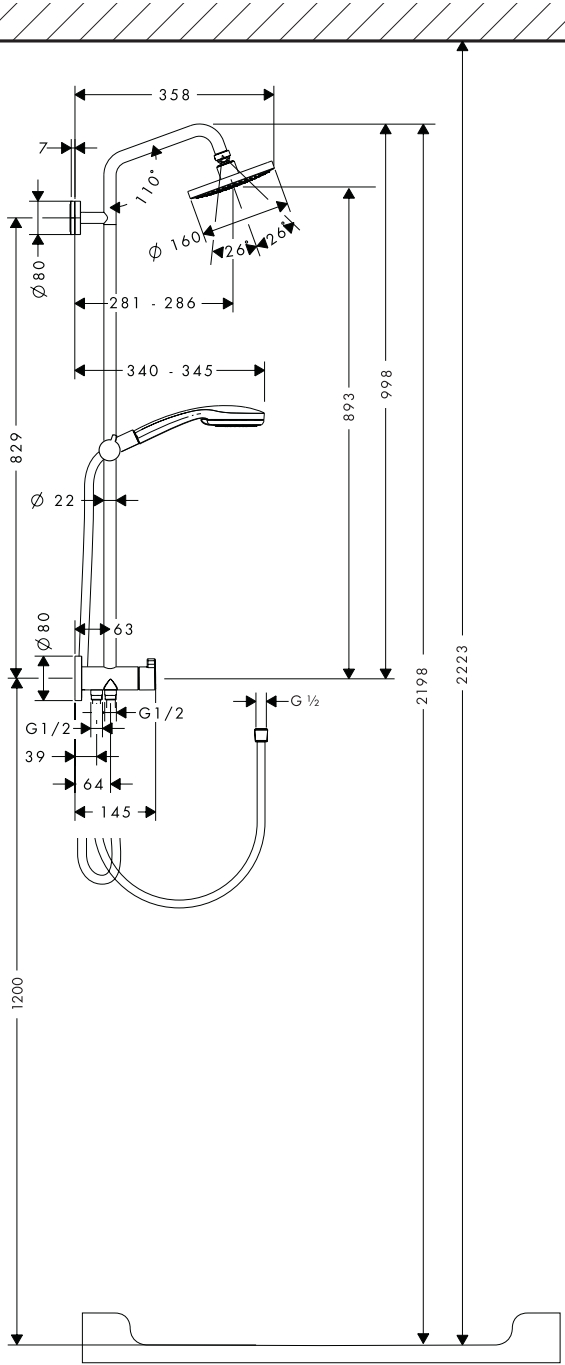

Showerpipe 240 Reno EcoSmart

27137000

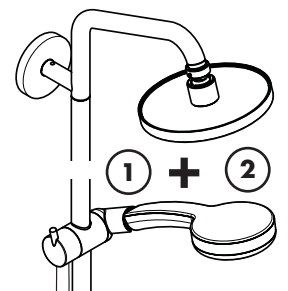
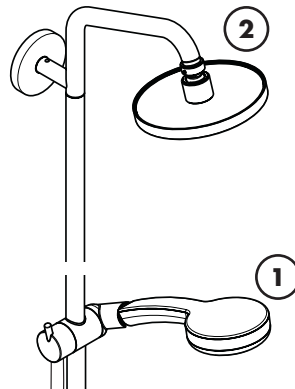
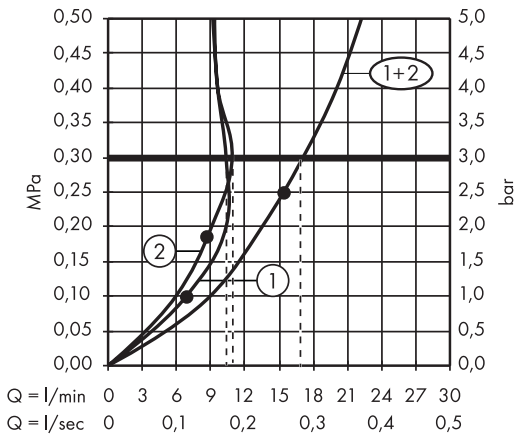

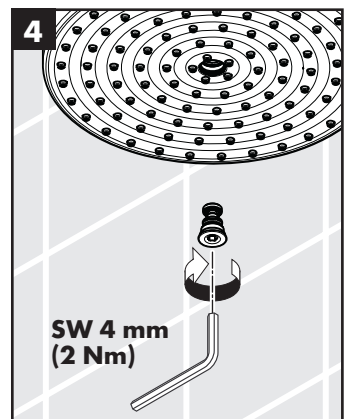
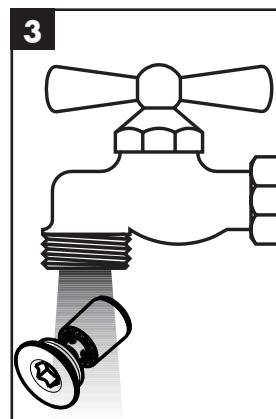
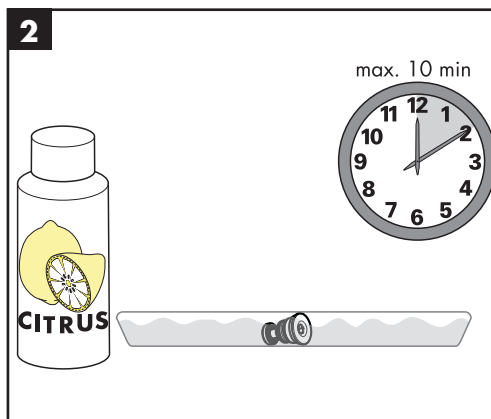
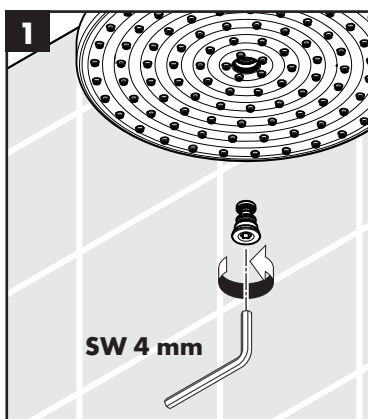
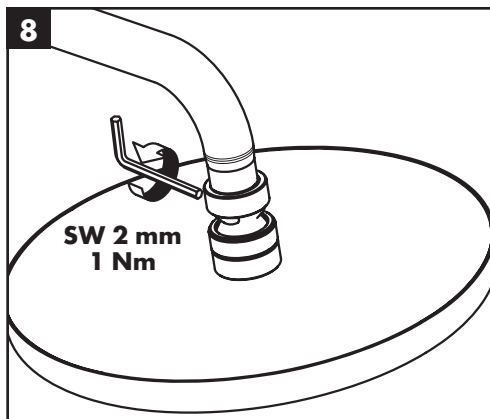
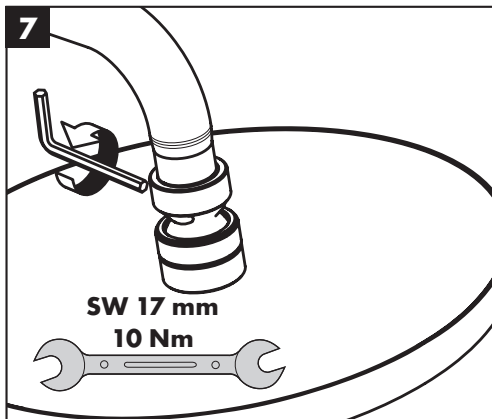
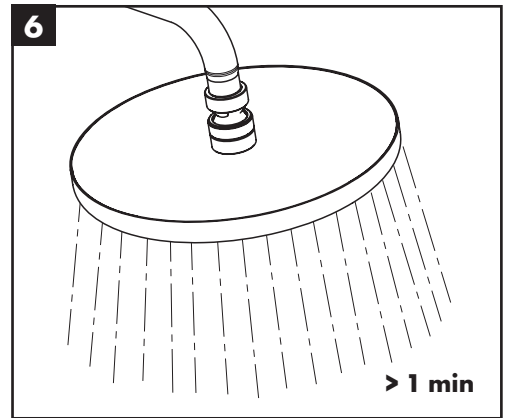
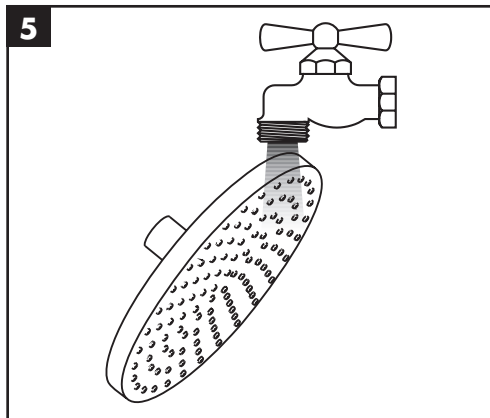
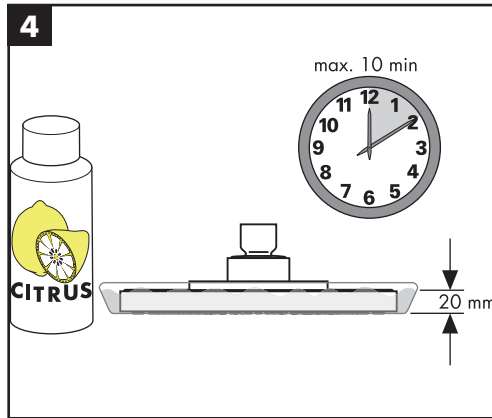
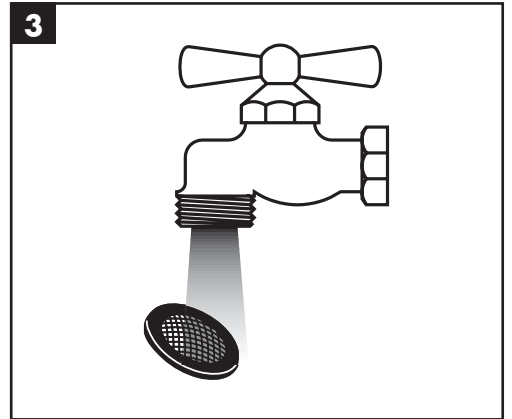
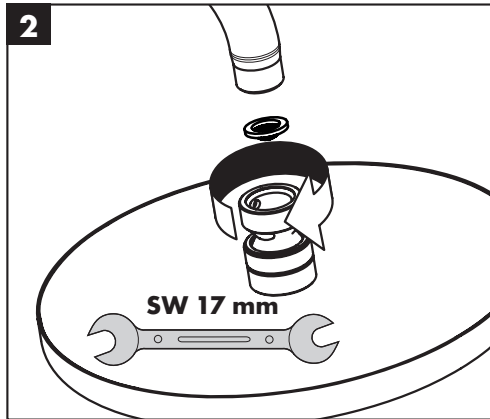
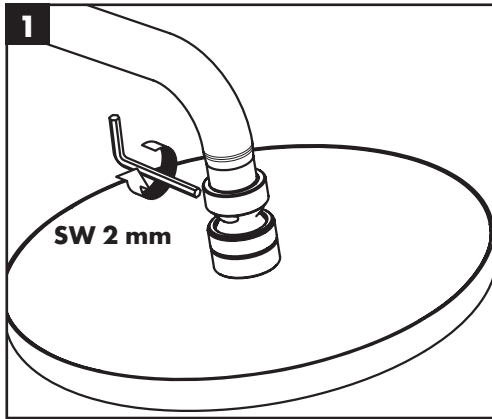

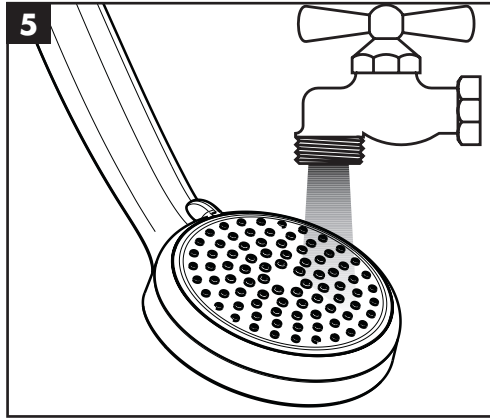
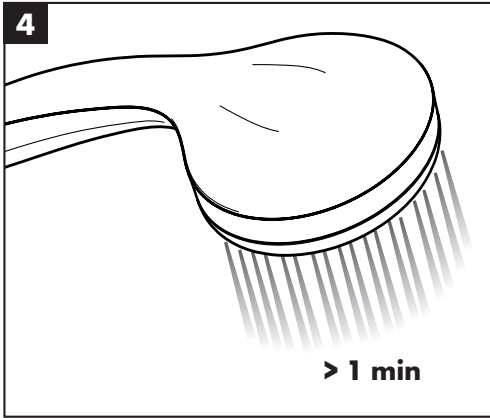
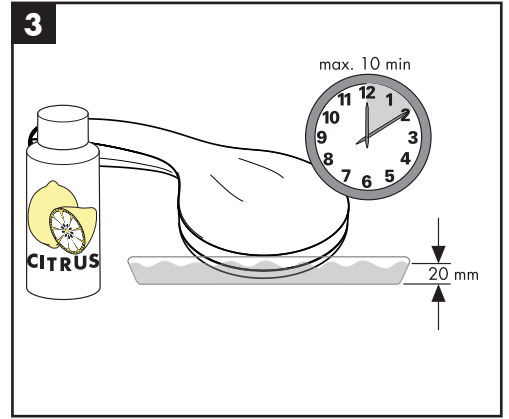
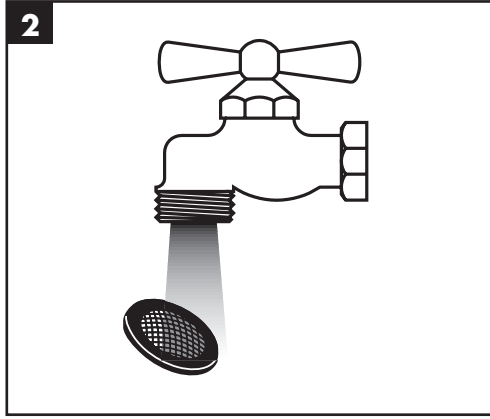
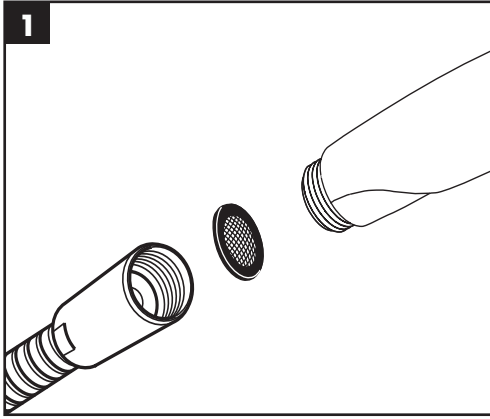



P-IX

DVGW

SVGW

ACS

WRAS

NF

KIWA

27137000 P-IX 19065/IBO

X



hansgrohe

Hansgrohe · Auestraße 5 – 9 · D-77761 Schiltach · Telefon +49 (0) 78 36/51-1282 · Telefax +49 (0) 7836/511440
E-Mail: info@hansgrohe.com · Internet: www.hansgrohe.com