

DE	Gebrauchsanleitung / Montageanleitung	2
FR	Mode d'emploi / Instructions de montage	3
EN	Instructions for use / assembly instructions	5
IT	Istruzioni per l'uso / Istruzioni per Installazione	6
ES	Modo de empleo / Instrucciones de montaje	8
NL	Gebruiksaanwijzing / Handleiding	9
DK	Brugsanvisning / Monteringsvejledning	11
PT	Instruções para uso / Manual de Instalação	12
PL	Instrukcja obsługi / Instrukcja montażu	14
CS	Návod k použití / Montážní návod	15
SK	Návod na použitie / Montážny návod	17
ZH	用户手册 / 组装说明	18
RU	Руководство пользователя / Инструкция по монтажу	20
HU	Használati útmutató / Szerelési útmutató	21
FI	Käyttöohje / Asennusohje	23
SV	Bruksanvisning / Monteringsanvisning	24
LT	Vartotojo instrukcija / Montavimo instrukcijos	26
HR	Upute za uporabu / Uputstva za instalaciju	27
TR	Kullanım kılavuzu / Montaj kılavuzu	29
RO	Manual de utilizare / Instrucțiuni de montare	30
EL	Οδηγίες χρήσης / Οδηγία συναρμολόγησης	32
SL	Navodilo za uporabo / Navodila za montažo	33
ET	Kasutusjuhend / Paigaldusjuhend	35
LV	Lietošanas pamācība / Montāžas instrukcija	36
SR	Uputstvo za upotrebu / Uputstvo za montažu	38
NO	Bruksanvisning / Montasjeveiledning	39
BG	Инструкция за употреба / Ръководство за монтаж	41
SQ	Udhëzuesi i përdorimit / Udhëzime rreth montimit	42
AR	دليل الاستخدام / تعليمات التجميع	45

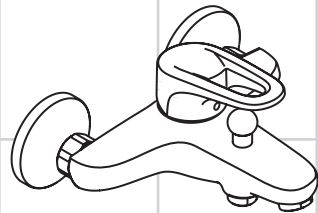

Metropol E
14470000 / 14470090

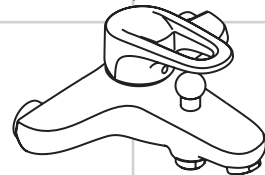

Metropol E
14474000

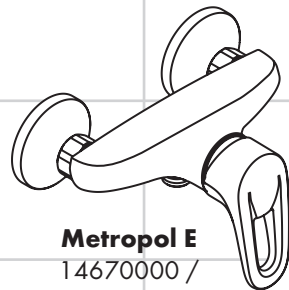



Metropol E
14670000 /
14670090



Metropol E
14674000



Sicherheitshinweise

-  Bei der Montage müssen zur Vermeidung von Quetsch- und Schnittverletzungen Handschuhe getragen werden.
-  Das Produkt darf nur zu Bade-, Hygiene- und Körperreinigungszwecken eingesetzt werden.
-  Große Druckunterschiede zwischen den Kalt- und Warmwasseranschlüssen müssen ausgeglichen werden.

Montagehinweise

- Vor der Montage muss das Produkt auf Transportschäden untersucht werden. Nach dem Einbau werden keine Transport- oder Oberflächenschäden anerkannt.
- Die Armatur muss nach den gültigen Normen montiert, gespült und geprüft werden.
- Hansgrohe Armaturen können in Verbindung mit hydraulisch und thermisch gesteuerten Durchlauferhitzern eingesetzt werden, wenn der Fließdruck mindestens 0,15 MPa beträgt.

Technische Daten

Betriebsdruck:	max. 1 MPa
Empfohlener Betriebsdruck:	0,1 – 0,5 MPa
Prüfdruck:	1,6 MPa
(1 MPa = 10 bar = 147 PSI)	
Heißwassertemperatur:	max. 80 °C
Empfohlene Heißwassertemperatur:	65 °C
Anschlussmaße:	150 ± 12 mm
Anschlüsse G 1/2:	kalt rechts - warm links
Thermische Desinfektion:	max. 70 °C / 4 min

Eigensicher gegen Rückfließen

Das Produkt ist ausschließlich für Trinkwasser konzipiert!

Symbolerklärung



Kein essigsäurehaltiges Silikon verwenden!



Justierung

Einhandmischer mit Warmwasserbegrenzung, Justierung siehe Seite 49. In Verbindung mit Durchlauferhitzern ist eine Warmwassersperre nicht notwendig.

Störung	Ursache	Abhilfe
Wenig Wasser	- Siebdichtung der Brause verschmutzt - Rückflussverhinderer sitzt fest	- Siebdichtung zwischen Brause und Schlauch reinigen - Rückflussverhinderer austauschen
Armatur schwergängig	- Kartusche defekt, verkalkt	- Kartusche austauschen
Armatur tropft	- Kartusche defekt	- Kartusche austauschen
Zu niedrige Warmwassertemperatur	- Warmwasserbegrenzung falsch eingestellt	- Warmwasserbegrenzung einstellen
Durchlauferhitzer schaltet nicht ein	- Drossel in der Handbrause nicht ausgebaut - Schmutzfangsiebe verschmutzt - Rückflussverhinderer sitzt fest	- Drossel aus der Handbrause entfernen - Schmutzfangsiebe reinigen / austauschen - Rückflussverhinderer austauschen

**Wartung** (siehe Seite 54)

Rückflussverhinderer müssen gemäß DIN EN 1717 regelmäßig in Übereinstimmung mit nationalen oder regionalen Bestimmungen (DIN 1988 einmal jährlich) auf ihre Funktion geprüft werden.

**Maße** (siehe Seite 50)**Durchflussdiagramm**
(siehe Seite 50)**Serviceteile** (siehe Seite 52)**Bedienung** (siehe Seite 55)**Reinigung**

siehe beiliegende Broschüre.

**Prüfzeichen** (siehe Seite 56)**Consignes de sécurité**

- ⚠ Lors du montage, porter des gants de protection pour éviter toute blessure par écrasement ou coupure.
- ⚠ Le système de douche ne doit servir qu'à se laver et à assurer l'hygiène corporelle.
- ⚠ Il est conseillé d'équilibrer les pressions de l'eau chaude et froide.

Instructions pour le montage

- Avant son montage, s'assurer que le produit n'a subi aucun dommage pendant le transport. Après le montage, tout dommage de transport ou de surface ne pourra pas être reconnu.
- La robinetterie doit être installée, rincée et contrôlée conformément aux normes valables.
- Les mitigeurs Hansgrohe fonctionnent également en association à des chauffe-eau à commande hydraulique ou thermique à condition que la pression soit au minimum de 0,15 MPa.

**Montage**
siehe Seite 46



Informations techniques

Pression de service autorisée: max. 1 MPa
 Pression de service conseillée: 0,1 - 0,5 MPa
 Pression maximum de contrôle: 1,6 MPa
 (1 MPa = 10 bar = 147 PSI)
 Température d'eau chaude: max. 80 °C
 Température recommandée: 65 °C
 Dimension d'arrivée: 150 ± 12 mm
 Raccordement G 1/2: froide à droite - chaude à gauche
 Désinfection thermique: max. 70 °C / 4 min

Avec dispositif anti-retour

Le produit est exclusivement conçu pour de l'eau potable!

Description du symbole



Ne pas utiliser de silicone contenant de l'acide acétique!



Etalonnage

Mitigeur avec limitation de la température: consulter la page 49 pour le réglage.
Une limitation de la température n'est pas nécessaire quand le mitigeur est alimenté par un chauffe-eau instantané.



Entretien (voir page 54)

Les clapets anti-retour doivent être examinés régulièrement conformément à la norme EN 1717 ou conformément aux dispositions nationales ou régionales quant à leur fonction (au moins une fois par an).



Dimensions (voir page 50)



Diagramme du débit (voir page 50)



Pièces détachées (voir pages 52)



Instructions de service (voir page 55)



Nettoyage

voir la brochure ci-jointe.



Classification acoustique et débit (voir page 56)

Dysfonctionnement

Origine

Solution

Pas assez d'eau

- Joint-filtre de douchette encrassé

- Nettoyer le joint-filtre entre la douchette et le flexible

- Clapet anti-retour bloque

- Changez le clapet antiretour

Dureté de fonctionnement

- Cartouche défectueuse, entartrée

- Changez la cartouche

Le mitigeur goutte

- Cartouche défectueuse

- Changez la cartouche

Température d'eau chaude trop basse, pas d'eau froide

- Limiteur de température mal positionné

- Positionner le limiteur de température

La chauffe-eau instantané ne s'allume pas

- Réducteur de débit non démonté

- Démontez le réducteur de débit de la douchette

- Filtres encrassés

- Nettoyez / changez les filtres

- Clapet anti-retour bloque

- Changez le clapet antiretour



Montage voir page 46



Safety Notes

- ⚠ Gloves should be worn during installation to prevent crushing and cutting injuries.
- ⚠ The shower system may only be used for bathing, hygienic and body cleansing purposes.
- ⚠ The hot and cold supplies must be of equal pressures.

Installation Instructions

- Prior to installation, inspect the product for transport damages. After it has been installed, no transport or surface damage will be honoured.
- The fitting must be installed, flushed and tested after the valid norms.
- Hansgrohe mixers can be used together with hydraulically and thermally controlled continuous flow heaters if the flow pressure is at least 0,15 MPa.

Technical Data

Operating pressure:	max. 1 MPa
Recommended operating pressure:	0,1 – 0,5 MPa
Test pressure:	1,6 MPa
(1 MPa = 10 bar = 147 PSI)	
Hot water temperature:	max. 80°C
Recommended hot water temp.:	65°C
Centre distance:	150 ± 12 mm
Connections G 1/2:	cold right - hot left
Thermal disinfection:	max. 70°C / 4 min

anti-pollution function

The product is exclusively designed for drinking water!

Symbol description



Do not use silicone containing acetic acid!



Adjustment

To adjust the hot water limiter on single lever mixers, please see page 49. No adjustment is necessary when using a continuous flow water heater.

Fault	Cause	Remedy
Insufficient water	- Shower filter seal dirty	- Clean filter seal between shower and hose
	- Non return valve hasn't moved back	- Exchange non return valves
Mixer stiff	- Cartridge defective, calcified	- Exchange cartridge
Mixer dripping	- Cartridge defective	- Exchange cartridge
Hot water temperature too low	- Hot water limiter incorrectly set	- Set hot water limiter
Instantaneous heater didn't work	- Flow limiter in handshower isn't removed	- Remove flow limiter
	- Filters are dirty	- Clean the filter / exchange filter
	- Non return valve hasn't moved back	- Exchange non return valves



Maintenance (see page 54)

The non return valves must be checked regularly according to DIN EN 1717 in accordance with national or regional regulations (at least once a year).



Dimensions (see page 50)



Flow diagram (see page 50)



Spare parts (see page 52)



Operation (see page 55)



Cleaning

see enclosed brochure.



Test certificate (see page 56)



Indicazioni sulla sicurezza

- ⚠ Durante il montaggio, per evitare ferite da schiacciamento e da taglio bisogna indossare guanti protettivi.
- ⚠ Il sistema doccia deve essere utilizzato esclusivamente per l'igiene del corpo.
- ⚠ Attenzione! Compensare le differenze di pressione tra i collegamenti dell'acqua fredda e dell'acqua calda.

Istruzioni per il montaggio

- Prima del montaggio è necessario controllare che non ci siano stati danni durante il trasporto. Una volta eseguito il montaggio, non verranno riconosciuti eventuali danni di trasporto o delle superfici.
- La rubinetteria deve essere installata, pulita e testata secondo le istruzioni riportate!
- I miscelatori Hansgrohe possono venire usati con caldaie a „bassa pressione“ se la pressione di flusso è almeno di 0,15 MPa.



Assembly see page 46



Dati tecnici

Pressione d'uso:	max. 1 MPa
Pressione d'uso consigliata:	0,1 - 0,5 MPa
Pressione di prova:	1,6 MPa
(1 MPa = 10 bar = 147 PSI)	
Temperatura dell'acqua calda:	max. 80 °C
Temp. dell'acqua calda consigliata:	65 °C
Distanza di raccordo:	150 ± 12 mm
Raccordi G 1/2:	fredda a destra - calda a sinistra
Disinfezione termica:	max. 70 °C / 4 min

Sicurezza antiriflusso

Il prodotto è concepito esclusivamente per acqua potabile!

Descrizione simbolo



Non utilizzare silicone contenente acido acetico!



Taratura

Regolazione del limitatore di erogazione di acqua calde dei miscelatori monocomando, vedere pagina 49. In combinazione con le caldaie istantanee, il limitatore di erogazione di acqua calda non è necessario.



Manutenzione (vedi pagg. 54)

La valvola di non ritorno deve essere controllata regolarmente come da DIN EN 1717, secondo le normative nazionali e regionali (almeno una volta all'anno).



Ingombri (vedi pagg. 50)



Diagramma flusso (vedi pagg. 50)



Parti di ricambio (vedi pagg. 52)



Procedura (vedi pagg. 55)



Pulitura

vedi il prospetto accluso.



Segno di verifica (vedi pagg. 56)



Problema	Possibile causa	Rimedio
Scarsità d'acqua	- Guarnizione del filtro della doccia sporca - Valvola antiriflusso non funziona correttamente	- Pulire la guarnizione del filtro tra doccia e flessibile - Sostituire la valvola antiriflusso
Miscelatore duro	- Cartuccia difettosa	- Sostituire la cartuccia
Miscelatore gocciola	- Cartuccia difettosa	- Sostituire la cartuccia
Temperatura dell'acqua calda	- Limitazione dell'acqua calda regolata male	- Regolare la limitazione dell'acqua calda
La caldaia istantanea non lavora	- Il limitatore di portata non è stato smontato dalla doccia - Filtri sporchi - Valvola antiriflusso non funziona correttamente	- Smontare il limitatore di portata dalla doccia - Pulire / sostituire i filtri - Sostituire la valvola antiriflusso



Montaggio vedi pagg. 46



Indicaciones de seguridad

-  Durante el montaje deben utilizarse guantes para evitar heridas por aplastamiento o corte.
-  La grifería solo debe ser utilizada para fines de baño, higiene y limpieza corporal.
-  Grandes diferencias de presión en servicio entre agua fría y agua caliente deben equilibrarse.

Indicaciones para el montaje

- Antes del montaje se debe examinar el producto contra daños de transporte. Después de la instalación so se reconoce ningún daño de transporte o de superficie.
- El grifo tiene que ser instalado, probado y testado, según las normas en vigor.
- Los mezcladores Hansgrohe pueden ser utilizados junto con calentadores continuos de agua que sean manejados de manera hidráulica o térmica, siempre que la presión en servicio ascienda a un mínimo de 0,15 MPa.

Datos técnicos

Presión en servicio:	max. 1 MPa
Presión recomendada en servicio:	0,1 - 0,5 MPa
Presión de prueba:	1,6 MPa
(1 MPa = 10 bar = 147 PSI)	
Temperatura del agua caliente:	max. 80°C
Temp. recomendada del agua caliente:	65°C
Racores excéntricos:	150 ± 12 mm
Racores excéntricos G 1/2:	a la derecha frío - a la izquierda caliente
Desinfección térmica:	max. 70°C / 4 min

Seguro contra el retorno

El producto ha sido concebido exclusivamente para agua potable.

Descripción de símbolos



No utilizar silicona que contiene ácido acético!



Ajuste

Uso como mezclador monomando con limitación del caudal de agua caliente: ver ajuste en pagina 49. En combinación con calentadores instantáneos no es necesario limitar el caudal de agua caliente.

Problema	Causa	Solución
Sale poca agua	- filtro de la ducha sucio	- limpiar/cambiar filtros entre flexo y ducha
	- válvula anti-retorno cerrada	- cambiar válvula anti-retorno
Manecilla va dura	- cartucho dañado	- cambiar el cartucho
Grifo pierde agua	- cartucho dañado	- cambiar el cartucho
Temperatura del agua demasiado baja no hay	- tope de agua caliente mal	- ajustar tope
Calentador instantáneo no se enciende	- no se ha quitado limitador de caudal de la teleducha	- quitar limitador de caudal
	- filtro de la ducha sucio	- limpiar/cambiar filtros
	- válvula anti-retorno cerrada	- cambiar válvula anti-retorno

**Mantenimiento** (ver página 54)

Las válvulas anti-retorno tienen que ser controladas regularmente según la norma DIN EN 1717, en acuerdo con las regulaciones nacionales o regionales (una vez al año, por lo menos).

**Dimensiones** (ver página 50)**Diagrama de circulación**
(ver página 50)**Repuestos** (ver página 52)**Manejo** (ver página 55)**Limpiar**

ver el folleto adjunto.

**Marca de verificación** (ver página 56)**Veiligheidsinstructies**

- ⚠ Bij de montage moeten ter voorkoming van kniel- en snijwonden handschoenen worden gedragen.
- ⚠ Het douchesysteem mag alleen voor het wassen, hygiënische doeleinden en voor de lichaamreiniging worden gebruikt.
- ⚠ Grote drukverschillen tussen de koud- en warmwatertoevoer dienen vermeden te worden.

Montage-instructies

- Vóór de montage moet het product gecontroleerd worden op transportschade. Na de inbouw wordt geen transport- of oppervlakteschade meer aanvaard.
- Leidingen doorspoelen volgens Norm. De mengkraan vervolgens monteren en controleren.
- Hansgrohe kranen kunnen samen met hydraulisch en thermisch gestuurde geisers gebruikt worden indien de uitstroomdruk min. 0,15 MPa bedraagt.

**Montaje**
ver página 46



Technische gegevens

Werkdruk: max. 1 MPa
 Aanbevolen werkdruk: 0,1 - 0,5 MPa
 Getest bij: 1,6 MPa
 (1 MPa = 10 bar = 147 PSI)
 Temperatuur warm water: max. 80 °C
 Aanbevolen warm water temp.: 65 °C
 Aansluitmaten: 150 ± 12 mm
 Aansluitingen G 1/2: koud rechts - warm links
 Thermische desinfectie: max. 70 °C / 4 min

Beveiligd tegen terugstromen

Het product is uitsluitend ontworpen voor drinkwater!

Symbolbeschrijving



Gebruik geen zuurhoudende siliconen!



Instellen

Eéngreepsmengkranen met warmwaterbegrenzing, instelling zie blz. 49. In combinatie met geisers is een warmwaterbegrenzing niet noodzakelijk.



Onderhoud (zie blz. 54)

Keerleppele moeten volgens DIN EN 1717 regelmatig en volgens plaatselijk geldende eisen op het functioneren gecontroleerd worden. (Tenminste een keer per jaar).



Maten (zie blz. 50)



Doorstroomdiagram (zie blz. 50)



Service onderdelen (zie blz. 52)



Bediening (zie blz. 55)



Reinigen

zie bijgevoegde brochure.



Keurmerk (zie blz. 56)

Storing

Weinig water

Oorzaak

- Zeefdichting handdouche verstopt
- Terugslagklep zit vast

Oplossing

- Zeefdichting handdouche reinigen
- Terugslagklep uitwisselen

Bediening zwaar

- Kardoes defect of verkalkt

- Kardoes uitwisselen

Mengkraan lekt

- Kardoes defect

- Kardoes uitwisselen

Temperatuur van warm water te laag

- Heetwaterbegrenzer verkeerd ingesteld

- Heetwaterbegrenzer instellen

Doorstroomtoestel schakelt niet in

- Begrenzer van handdouche niet verwijderd

- Begrenzer uit handdouche verwijderen

- Vuilzeef verstopt

- Vuilvangzeef reinigen / uitwisselen

- Terugslagklep zit vast

- Terugslagklep uitwisselen



Montage zie blz. 46



Sikkerhedsanvisninger

- ⚠ Ved monteringen skal der bruges handsker for at undgå kvæstelser og snitsår.
- ⚠ Brusersystemet må kun bruges til bade-, hygiejne og rengøringsformål.
- ⚠ Større trykforskelle mellem koldt og varmt vand bør udjævnes.

Monteringsanvisninger

- Før monteringen skal produktet kontrolleres for transportskader. Efter monteringen godkendes transportskader eller skader på overfladen ikke længere.
- Ifølge gældende regler, skal armaturet monteres, skylles igennem og afprøves.
- Hansgrohe armaturer kan anvendes i forbindelse med hydraulisk- og termiskstyrede gennemstrømningsvandvarmere ved et vandtryk på 0,15 MPa.

Tekniske data

Driftstryk:	max. 1 MPa
Anbefalet driftstryk:	0,1 – 0,5 MPa
Prøvetryk:	1,6 MPa
(1 MPa = 10 bar = 147 PSI)	
Varmtvandstemperatur:	max. 80 °C
Anbefalet varmtvandstemperatur:	65 °C
Tilslutningsmål:	150 ± 12 mm
Tilslutninger G 1/2:	Koldt højre - varmt venstre
Termisk desinfektion:	max. 70 °C / 4 min

Med indbygget kontraventil

Produktet er udelukkende beregnet til drikkevand!

Symbolbeskrivelse



Der må ikke benyttes eddikesyreholdig silikone!



Forindstilling

Etgrebsarmaturer med varmtvandsbegrænsning, justering se side 49. I forbindelse med gennemstrømningsvandvarmer er en varmtvandsbegrænsning ikke nødvendig.

Fejl	Årsag	Hjælp
For lidt vand	- Sien mellem bruser og slange er snavset - Kontraventilen hænger	- Rengør sien mellem bruser og slange - Udskift kontraventil
Grebet går trægt	- Kartusche defekt, tilkalket	- Udskift kartusche
Armaturet drypper	- Defekt kartusche	- Udskift kartusche
For lav varmtvands-temperatur	- Varmtvandsbegrænsningen er forkert indstillet	- Indstil varmtvandsbe-grænsningen
Vandvarmeren går ikke i gang	- Vandsparen i håndbruseren er ikke fjernet - Smudsfangsien er snavset - Kontraventilen hænger	- Afmonter vandsparen i håndbruseren - Rengør/udskift smudsfangsi - Udskift kontraventil



Service (se s. 54)

Ifølge DIN EN 1717 skal gennemstrømningsbegrænsere i overensstemmelse med nationale regler afprøves regelmæssigt (mindst en gang om året).



Målene (se s. 50)



Gennemstrømningsdiagram (se s. 50)



Reserve dele (se s. 52)



Brugsanvisning (se s. 55)



Rengøring

se venligst den vedlagte brochure.



Godkendelse (se s. 56)



Avisos de segurança

- ⚠ Durante a montagem devem ser utilizadas luvas de protecção, de modo a evitar ferimentos resultantes de entalamentos e de cortes.
- ⚠ O sistema de duche só pode ser utilizado para fins de higiene pessoal.
- ⚠ Grandes diferenças entre as pressões das águas quente e fria devem ser compensadas.

Avisos de montagem

- Antes da montagem deve-se controlar o produto relativamente a danos de transporte. Após a montagem não são aceites quaisquer danos de transporte ou de superfície.
- A misturadora deve ser instalada, purgada e testada de acordo com as normas em vigor.
- As misturadoras Hansgrohe podem ser utilizadas com esquentadores (de controlo térmico ou hidráulico) desde que a pressão de utilização seja, no mínimo, de 0,15 MPa.



Montering se s. 46



Dados Técnicos

Pressão de funcionamento:	max. 1 MPa
Pressão de func. recomendada:	0,1 – 0,5 MPa
Pressão testada:	1,6 MPa
(1 MPa = 10 bar = 147 PSI)	
Temperatura da água quente:	max. 80 °C
Temp. água quente recomendada:	65 °C
Distância entre eixos:	150 ± 12 mm
Ligações G 1/2:	fria à direita - quente à esquerda
Desinfecção térmica:	max. 70 °C / 4 min

Função anti-retorno e anti-vácuo

Este produto foi única e exclusivamente concebido para água potável!

Descrição do símbolo



Não utilizar silicone que contenha ácido acético!



Afinação

Misturadora monocomando equipada com limitador de temperatura (vide pág. 49). Em combinação com caldeira ou esquentador instantâneo o limitador de água quente não se aplica.



Manutenção (ver página 54)

As válvulas anti-retorno devem ser verificadas regularmente de acordo com a DIN EN 1717 segundo os regulamentos nacionais ou regionais (pelo menos uma vez por ano).



Medidas (ver página 50)



Fluxograma (ver página 50)



Peças de substituição (ver página 52)



Funcionamento (ver página 55)



Limpeza

consultar a seguinte brochura.



Marca de controlo (ver página 56)

Falha

Causa

Solução

Água insuficiente

- Filtro do vedante do chuveiro sujo

- Limpar o filtro entre o chuveiro e o tubo flexível

- Válvula anti-retorno está presa

- Trocar a válvula anti-retorno

Misturadora a perra

- Cartucho defeituoso, calcificado

- Substituir o cartucho

Misturadora a pingar

- Cartucho defeituoso

- Substituir o cartucho

Temperatura da água quente muito baixa

- O limitador de temperatura está incorrectamente colocado

- Regular o limitador de temperatura

O esquentador instantâneo não funciona

- O limitador de caudal não foi retirado

- Retirar o limitador de caudal

- Filtro sujo

- Limpar / trocar o filtro

- Válvula anti-retorno está presa

- Trocar a válvula anti-retorno



Montagem ver página 46



Wskazówki bezpieczeństwa

- ⚠ Aby uniknąć zranień, takich jak zgniecenia czy przecięcia, podczas montażu należy nosić rękawice.
- ⚠ Pysznic może być używany tylko do kąpieli, higieny i czyszczenia ciała.
- ⚠ Znaczne różnice ciśnień na dopływach ciepłej i zimnej wody muszą zostać wyrównane.

Wskazówki montażowe

- Przed montażem należy skontrolować produkt pod kątem szkód transportowych. Po montażu nie widać żadnych szkód transportowych ani szkód na powierzchni.
- Armatura musi być zamontowana, przepłukana i wypróbowana według obowiązujących norm.
- Armatura Hansgrohe może być stosowana z przepływowymi podgrzewaczami wody sterowanymi hydraulicznie i termicznie w przypadku, gdy ciśnienie przepływu wynosi co najmniej 0,15 MPa.

Dane techniczne

Ciśnienie robocze:	maks. 1 MPa
Zalecane ciśnienie robocze:	0,1 – 0,5 MPa
Ciśnienie próbne:	1,6 MPa
(1 MPa = 10 bary = 147 PSI)	
Temperatura wody gorącej:	maks. 80 °C
Zalecana temperatura wody gorącej:	65 °C
Wymiary przyłącza:	150 ± 12 mm
Przyłącza G 1/2:	Zimna prawo – ciepła lewo
Dezynfekcja termiczna:	maks. 70 °C / 4 min

Samoistnie zabezpieczony przed przepływem zwrotnym
Produkt stworzono wyłącznie do wody pitnej!

Opis symbolu



Nie stosować silikonów zawierających kwas octowy!



Ustawianie

Mieszacz jednouchwytowy z ogranicznikiem temperatury wody, ustawianie, patrz str. 49. W połączeniu z przepływowym podgrzewaczem wody ogranicznik temperatury wody nie jest konieczny.

Usterka	Przyczyna	Pomoc
Mała ilość wody	- Zabrudzona uszczelka z sitkiem w prysznicu - Mocno osadzone zabezpieczenie przed przepływem zwrotnym	- Oczyszczyć uszczelkę z sitkiem pomiędzy prysznicem a wężem - Wymienić zabezpieczenie przed przepływem zwrotnym
Uchwyt armatury pracuje z wysiłkiem	- Uszkodzony wkład, zakamieniony	- Wymiana wkładu
Armatura cieknie	- Uszkodzony wkład	- Wymiana wkładu
Za niska temperatura ciepłej wody	- Niewłaściwe ustawienie ogranicznik ciepłej wody	- Ustawić ogranicznik ciepłej wody
Przepływowy podgrzewacz wody nie załącza się	- Dławik przepływu nie został usunięty z prysznicu ręcznego - Zabrudzone sitka - Mocno osadzone zabezpieczenie przed przepływem zwrotnym	- Usunąć dławik z prysznicu ręcznego - Oczyszczyć/ wymienić sitka - Wymienić zabezpieczenie przed przepływem zwrotnym

**Konserwacja** (patrz strona 54)

Działanie zabezpieczeń przed przepływem zwrótnym, zgodnie z normą DIN EN 1717 i miejscowymi przepisami, musi być kontrolowane (DIN 1988, raz w roku).

**Wymiary** (patrz strona 50)**Schemat przepływu**
(patrz strona 50)**Części serwisowe** (patrz strona 52)**Obsługa** (patrz strona 55)**Czyszczenie**

patrz dołączona broszura.

**Znak jakości** (patrz strona 56)**Bezpečnostní pokyny**

- ⚠ Pro zabránění řezným zraněním a pohmožděním je nutné při montáži nosit rukavice.
- ⚠ Produkt smí být používán pouze ke koupání a za účelem tělesné hygieny.
- ⚠ Je nutné vyrovnat velké rozdíly tlaku mezi přípoji studené a teplé vody.

Pokyny k montáži

- Před montáží je třeba produkt zkontrolovat, zda nebyl při transportu poškozen. Po zabudování nebudou uznány žádné škody způsobené transportem nebo poškození povrchu.
- Armatura se musí montovat, proplachovat a testovat podle platných norem.
- Armatury Hansgrohe je možno používat v kombinaci s hydraulicky a tepelně řízenými průtokovými ohřivači v případě, že tlak činí minimálně 0,15 MPa.

**Montáž**
patrz strona 46



Technické údaje

Provozní tlak:	max. 1 MPa
Doporučený provozní tlak:	0,1 – 0,5 MPa
Zkušební tlak:	1,6 MPa
(1 MPa = 10 bar = 147 PSI)	
Teplota horké vody:	max. 80 °C
Doporučená teplota horké vody:	65 °C
Rozteč připojení:	150 ± 12 mm
Přípoje G 1/2:	studená vpravo - teplá vlevo
Tepelná desinfekce:	max. 70 °C / 4 min

Vlastní čištění proti zpětnému nasátí.

Výrobky Hansgrohe jsou vhodné pro přímý kontakt s pitnou vodou.

Popis symbolů



Nepoužívat silikon s obsahem kyseliny octové!



Nastavení

Páková baterie s omezením horké vody, seřízení viz. str. 49. Ve spojení s průtokovými ohřívači není uzávěr teplé vody nutný.



Údržba (viz strana 54)

U zpětných ventilů se musí podle DIN EN 1717 v souladu s národními nebo regionálními předpisy testovat jejich funkčnost (alespoň jednou ročně).



Rozměry (viz strana 50)



Diagram průtoku (viz strana 50)



Servisní díly (viz strana 52)



Ovládání (viz strana 55)



Čištění

viz přiložená brožura.



Zkušební značka (viz strana 56)

Porucha

Málo vody

Příčina

- Sítko v těsnění u sprchy zanesené
- Zpětný ventil je zablokovaný

Odstranění

- Vyčistit sítko v těsnění mezi sprchou a hadicí
- Vyměnit zpětný ventil

Armatura jde ztěžka

- Kartuše je vadná, zanesená vodním kamenem

- Kartuši vyměnit

Armatura odkapává

- Kartuše je vadná

- Kartuši vyměnit

Nízká teplota teplé vody

- Špatně nastavená zarážka pro teplou vodu

- Seřídít zarážku pro teplou vodu

Průtokový ohřívač nezapíná

- Není odstraněn kroužek ze sprchy
- Sítko na zachycování nečistot je zanesené
- Zpětný ventil je zablokovaný

- Odstranit kroužek ze sprchy
- Vyčistit případně vyměnit sítko
- Vyměnit zpětný ventil





Bezpečnostné pokyny

- ⚠ Pri montáži musíte nosiť rukavice, aby ste predišli pomliaždeninám a rezným poraneniam.
- ⚠ Produkt sa smie používať len na kúpanie a telesnú hygienu.
- ⚠ Veľké rozdiely v tlaku medzi prípojkami studenej a teplej vody musia byť vyrovnané.

Pokyny pre montáž

- Pred montážou musíte produkt skontrolovať, či nebol počas transportu poškodený. Po zabudovaní nebudú uznané žiadne škody spôsobené transportom alebo poškodenia povrchu.
- Armatúra sa musí montovať, preplachovať a testovať podľa platných noriem.
- Batérie Hansgrohe môžete používať v spojení s hydraulickými a tepelne ovládanými prietokovými ohrievačmi, ak je tlak minimálne 0,15 MPa.

Technické údaje

Prevádzkový tlak:	max. 1 MPa
Doporučený prevádzkový tlak:	0,1 – 0,5 MPa
Skúšobný tlak:	1,6 MPa
(1 MPa = 10 bar = 147 PSI)	
Teplota teplej vody:	max. 80 °C
Doporučená teplota teplej vody:	65 °C
Prípájacie rozmery:	150 ± 12 mm
Prípoje G 1/2:	studená vpravo - teplá vľavo
Termická dezinfekcia:	max. 70 °C / 4 min

Vlastná poistka proti spätnému nasatiu.

Výrobok je koncipovaný výhradne pre pitnú vodu!

Popis symbolov



Nepoužívať silikón s obsahom kyseliny octovej!

Nastavenie

Páková batéria s obmedzením teplej vody, nastavenie viď .str. 49. V spojení s prietokovými ohrievačmi nie je uzáver teplej vody nutný.

Porucha	Príčina	Pomoc
Málo vody	- Sitko v tesnení sprchy je znečistené	- Vyčistiť sitko tesnení medzi sprchou a hadicou
	- Obmedzovač spätného nasatia je zablokovaný	- Vymeniť obmedzovač spätného nasatia
Armatúra "chodí" ťažko	- Kartuša je poškodená, vápenaté usadeniny	- Vymeniť kartušu
Z armatúry kvapká voda	- Kartuša je poškodená	- Vymeniť kartušu
Nízka teplota teplej vody	- Nesprávne nastavená zádržka na teplú vodu	- Nastavenie zádržky na teplú vodu
Prietokový ohrievač nezapína	- Nie je odstránený krúžok zo sprchy	- Odstrániť krúžok zo sprchy
	- Sitko v tesnení sprchy je znečistené	- Vyčistiť resp. vymeniť sitko
	- Obmedzovač spätného nasatia je zablokovaný	- Vymeniť obmedzovač spätného nasatia



Údržba (vid' strana 54)

Pri spätných ventiloch sa musí podľa DIN EN 1717 v súlade s národnými alebo regionálnymi predpismi testovať ich funkčnosť (aspoň raz ročne).



Rozmery (vid' strana 50)



Diagram prietoku (vid' strana 50)



Servisné diely (vid' strana 52)



Obsluha (vid' strana 55)



Čistenie

nájdete v priloženej brožúre.



Osvedčenie o skúške (vid' strana 56)

⚠️ 安全技巧

- △ 装配时为避免挤压和切割受伤，必须戴上手套。
- △ 淋浴系统只允许作为洗浴、卫生和洁身之用。
- △ 冷热水管间过大的压力差必须予以平衡。

安装提示

- 安装前必须检查产品是否受到运输损害。安装后将不认可运输损害或表面损伤。
- 必须按照现行的规定安装，冲洗和测试产品。
- 如果水压达到0,15 MPa以上，汉斯格雅双手柄龙头可以和液压式或热控式连续流热水器一起使用。





技术参数

工作压强: 最大 1 MPa
 推荐工作压强: 0,1 0,5 MPa
 测试压强: 1,6 MPa
 (1 MPa = 10 bar = 147 PSI)
 热水温度: 最大 80° C
 推荐热水温度: 65° C
 中心距离: 150 ± 12 mm
 连接管线G 1/2: 左热右冷
 热力消毒: 最大70° C / 4 分钟

自动防止回流

该产品专为饮用水设计!

符号说明



请勿使用含有乙酸的硅!



调节

带有热水控制器的单手柄龙头的调节方法, 参见第 49 页。 如果与连续流热水器一起使用, 则不必作任何调节。



保养 (参见第 54 页)

单向阀必须在符合国家或当地的法律的情况下按照DIN EN 1717定期检查 (至少一年一次)。



大小 (参见第 50 页)



流量示意图

(参见第 50 页)



备用零件 (参见第 52 页)



操作 (参见第 55 页)



清洗

附有小手册。



检验标记 (参见第 56 页)

问题	原因	补救
龙头出水量小	- 花洒滤网有垃圾堵塞 - 单向阀无法回缩	- 清洗花洒和软管间的过滤密封件 - 更换单向阀
龙头不灵活	- 滤筒损坏, 结垢	- 更换滤筒
龙头滴水	- 滤筒损坏	- 更换滤筒
热水温度过低	- 热水控制器设置错误	- 设置热水控制器
燃气热水器不工作	- 手持花洒的流量限制器没有转动 - 过滤网有垃圾堵塞 - 单向阀无法回缩	- 转动流量限制器 - 清洗过滤网/更换过滤网 - 更换单向阀



安装

参见第 46 页



Указания по технике безопасности

- ⚠ Во время монтажа следует надеть перчатки во избежание прищемления и порезов.
- ⚠ Изделие разрешается использовать только в гигиенических целях: для принятия ванны и личной гигиены.
- ⚠ донного клапа. Перед установкой смесителя необходимо регулировочными кранами выровнять давление холодной и горячей воды при помощи вентилей регулирующих подачу воды в квартиру.

Указания по монтажу

- Перед монтажом следует проверить изделие на предмет повреждений при перевозке. После монтажа претензии о возмещении ущерба за повреждения при перевозке или повреждения поверхностей не принимаются.
- Смеситель должен быть смонтирован по действующим нормам и в соответствии с настоящей инструкцией, проверен на герметичность и безупречность работы.
- Арматуры Hansgrohe могут использоваться в комбинации с проточными нагревателями с гидравлическим и термическим управлением, если давление истечения составляет не менее 0,15 МПа.

Технические данные

Рабочее давление: не более. 1 МПа
 Рекомендуемое рабочее давление: 0,1 – 0,5 МПа
 Давления: 1,6 МПа
 (1 МПа = 10 bar = 147 PSI)
 Температура горячей воды: не более. 80 °C
 Рекомендуемая темп. гор. воды: 65 °C
 Размеры подключения: 150 ± 12 mm
 Подключение G 1/2: холодная справа - горячая слева
 Термическая дезинфекция: не более. 70 °C / 4 мин

укомплектован клапаном обратного тока воды

Изделие предназначено исключительно для питьевой воды!

Описание символов



Не применяйте силикон, содержащий уксусную кислоту.



Подгонка

Однорычажный смеситель имеет ограничитель расхода горячей воды (см. Стр. 49: юстировка). В комбинации с проточными нагревателями не разрешается установка блокировка горячей воды!

Неисправность	Причина	Устранение неисправности
недостаточный давление (если устан напор воды)	- Фильтр душа загрязнен - Клапан обратного тока заедает	- Очистить фильтр - Замените клапаны обратного течения
Арматура работает с усилием	- Картридж неисправен, засорение накипью	- Замените картридж
Арматура протекает	- Картридж неисправен	- Замените картридж
Температура горячей воды слишком низкая	- Ограничение горячей воды отрегулировано неправильно	- Отрегулируйте ограничение горячей воды
Проточный нагреватель не включается	- Дроссель не удален из ручного душа - Грязеулавливающие сита загрязнены - Клапан обратного тока заедает	- Извлеките дроссель из ручного душа - Очистите / замените грязеулавливающие сита - Замените клапаны обратного течения

**Техническое обслуживание**
(см. стр. 54)

Защита обратного тока должна регулярно проверяться (минимум один раз в год) по стандарту DIN EN 1717 или в соответствии с национальными или региональными нормативами

**Размеры** (см. стр. 50)**Схема потока**
(см. стр. 50)**Комплект** (см. стр. 52)**Эксплуатация** (см. стр. 55)**Очистка**

см прилагаемая брошюра.

**Знак технического контроля**
(см. стр. 56)**Biztonsági utasítások**

- ⚠ A szerelésnél a zúzódások és vágási sérülések elkerülése érdekében kesztyűt kell viselni.
- ⚠ A terméket csak fürdéshez, mosakodáshoz, és egészségügyi tisztálkodáshoz szabad használni.
- ⚠ A hidegvíz- és a melegvíz-csatlakozások közötti nagy nyomáskülönbséget kikell egyenlíteni!

Szerelési utasítások

- A szerelés előtt ellenőrizni kell, hogy a terméknek nincs-e szállítási sérülése. Beépítés után a szállítási- vagy felületi sérüléseket nem ismerik el.
- A csaptelepét az érvényben lévő előírásoknak megfelelően kell felszerelni, átöblíteni és ellenőrizni.
- A Hangsrohe csaptelepépek hidraulikus és termikus vezérlésű átfolyós melegítővel kapcsolatban is használhatóak, ha az átfolyó nyomás legalább 0,15 MPa.

**Монтаж**
см. стр. 46



Műszaki adatok

Üzemi nyomás:	max. 1 MPa
Ajánlott üzemi nyomás:	0,1 – 0,5 MPa
Nyomáspróba:	1,6 MPa
(1 MPa = 10 bar = 147 PSI)	
Forróvíz hőmérséklet:	max. 80 °C
Forróvíz javasolt hőmérséklete:	65 °C
Csatlakozási méret:	150 ± 12 mm
G 1/2 csatlakozás:	hideg jobbra – meleg balra
Termikus fertőtlenítés:	max. 70 °C / 4 perc

Visszafolyás gátlóval

A terméket kizárólag ivóvízhez tervezték!

Szimbólumok leírása



Ne használjon ecetsavtartalmú szilikon!



Beállítás

Az egykaros, melegvíz-korlátozóval ellátott keverő csaptelep beállítását lásd a 49. oldalon. Az átfolyó rendszerű vízmelegítőknél nem szükséges a melegvíz-korlátozó.

Hiba

Kevés víz

Ok

- a zuhany szűrőtömítése koszos
- A visszafolyásgátló beragadt.

Megoldás

- a zuhany és a cső közötti szűrőt ki kell tisztítani
- A visszafolyásgátló kicserélése javasolt.

Nehezen nyitható a csap.

- A kerámiabetét meghibásodott, elvízkövesedett.

- A kerámiabetétet ki kell cserélni.

Csőpög a csap.

- A kerámiabetét meghibásodott.

- A kerámiabetétet ki kell cserélni.

túl alacsony melegvíz hőmérséklet

- A melegvíz szabályozó rosszul van beállítva.

- A melegvíz szabályozót újra be kell állítani.

Az átfolyós vízmelegítő nem kapcsol be.

- Nincs kiszerve a zuhanyrózsából a vízmennyiség szabályozó.
- A szennyfogó szűrő koszos.
- A visszafolyásgátló beragadt.

- El kell távolítani a vízmennyiség szabályozót.
- A szennyfogó szűrőt tisztítani/cserélni kell.
- A visszafolyásgátló kicserélése javasolt.



Karbantartás (lásd a 54. oldalon)

A visszafolyásgátlók működése a DIN EN 1717 szabványnak megfelelően, a nemzeti vagy területi rendelkezésekkel összhangban, évente egyszer ellenőrizendő!



Méretet (lásd a 50. oldalon)



Átfolyási diagramm

(lásd a 50. oldalon)



Tartozékok (lásd a 52. oldalon)



Használat (lásd a 55. oldalon)



Tisztítás

lásd a mellékelt brosúrát.



Vizsgajel (lásd a 56. oldalon)



Szerelés lásd a 46. oldalon



Turvallisuusohjeet

- △ Asennuksessa on käytettävä käsineitä puristumien ja viiltojen aiheuttamien tapaturmien estämiseksi.
- △ Suihkujärjestelmää saa käyttää ainoastaan kylpy-, hygienia- ja puhdistustarkoituksiin.
- △ Suuret paine-erot kylmä- ja kuumavesiliitäntöjen välillä on tasattava.

Asennusohjeet

- Ennen asennusta on tarkastettava tuotteen mahdolliset kuljetusvahingot. Asennuksen jälkeen kuljetus- ja pintavaurioita ei hyväksytä.
- Kaluste on asennettava, huuhdeltava ja tarkastettava voimassa olevien määräysten mukaisesti.
- Hansgrohe kalusteita voi käyttää hydraulisesti tai termisesti ohjattujen läpivirtauskuumentimien yhteydessä, jos virtauspaine on vähintään 0,15 MPa.

Tekniset tiedot

Käyttöpaine:	maks. 1 MPa
Suosittelut käyttöpaine:	0,1 – 0,5 MPa
Koestuspaine:	1,6 MPa
(1 MPa = 10 bar = 147 PSI)	
Kuuman veden lämpötila:	maks. 80 °C
Kuuman veden suosituslämpötila:	65 °C
Liitäntämitat:	150 ± 12 mm
Liittimet G 1/2:	kylmä oikealla - kuuma vasemmalla
Lämpödesinfektio:	maks. 70 °C / 4 min

Estää itsestään paluuvirtauksen

Tuote on suunniteltu käytettäväksi ainoastaan juomaveden kanssa!

Merkin kuvaus



Älä käytä etikahappopitoista silikonia!



Säätö

Yksivipuinen sekoittaja lämpimän veden rajoituksella, katso säätö sivulta 49. Lämpimän veden rajoitusta ei tarvita läpivirtauskuumentimen yhteydessä.

Häiriö

Vähän vettä

Syy

- Käsिसuihkun sihtitiiviste likaantunut
- Suuntaisventtiili juuttunut

Toimenpide

- Puhdista suihkukahvan ja letkun välissä oleva sihtitiiviste
- Vaihda suuntaisventtiili

Hana on raskaskäyttöinen

- Patruuna rikki, kalkkikerrostumia

- Vaihda patruuna

Hanasta tippuu vettä

- Patruuna rikki

- Vaihda patruuna

Lämminveden lämpötila liian alhainen

- Lämminveden rajoitin väärin säädetty

- Säädä lämminveden rajoitin

Läpimenokuumentimen ei kytkeydy päälle

- Käsिसuihkussa olevaa kuristinta ei ole poistettu
- Likasihdit likaantuneet
- Suuntaisventtiili juuttunut

- Poista kuristin käsिसuihkusta
- Puhdista / vaihda likasihdit
- Vaihda suuntaisventtiili



Huolto (katso sivu 54)

Vastaventiilien toiminta on tarkastettava säännöllisesti paikallisten ja kansallisten määräysten mukaisesti (DIN 1988, kerran vuodessa).



Mitat (katso sivu 50)



Virtausdiagrammi (katso sivu 50)



Varaosat (katso sivu 52)



Käyttö (katso sivu 55)



Puhdistus

katso oheinen esite.



Koestusmerkki (katso sivu 56)



Säkerhetsanvisningar

- ⚠ Handskar ska bäras under monteringsarbetet så att man kan undvika kläm- och skärskadorgen werden.
- ⚠ Produkten får bara användas till kroppshygien med bad och dusch.
- ⚠ Stora tryckskillnader mellan anslutningarna för varmt och kallt vatten måste utjämnas.

Monteringsanvisningar

- Det måste undersökas om produkten har transportskador innan den monteras. Efter monteringen accepteras inga transport- eller ytskiktsskador.
- Armaturen måste installeras, genomspolas och testas enligt gällande föreskrifter.
- Hansgrohe blandare kan användas tillsammans med hydrauliskt och termiskt styrda varmvattenberedare när flödestrycket uppgår till minst 0,15 MPa.





Tekniska data

Driftstryck:	max. 1 MPa
Rek. driftstryck:	0,1 – 0,5 MPa
Tryck vid provtryckning: (1 MPa = 10 bar = 147 PSI)	1,6 MPa
Varmvattentemperatur:	max. 80 °C
Rek. varmvattentemp.:	65 °C
Anslutningsmått:	150 ± 12 mm
Anslutningar G 1/2:	kallt höger – varmt vänster
Termisk desinfektion:	max. 70 °C / 4 min

Självspärr mot återflöde

Produkten är enbart avsedd för dricksvatten!

Symbolförklaring



Använd inte silikon som innehåller ättiksyra!



Justering

Enhandsblandare med varmvattenreglering, justering se sidan 49. Vid användning tillsammans med varmvattenberedare behövs ingen varmvattenreglering.



Skötsel (se sidan 54)

Backventilers funktion måste kontrolleras regelbundet enligt nationella eller regionala bestämmelser (DIN 1988 en gång per år) i enlighet med DIN EN 1717.



Måtten (se sidan 50)



Flödesschema

(se sidan 50)



Reservdelar (se sidan 52)



Hantering (se sidan 55)



Rengöring

se den medföljande broschyren.



Testsigill (se sidan 56)

Störning

Orsak

Åtgärd

För lite vatten

- Silfiltret i duschen smutsigt

- Rengör silfiltret mellan slangen och termostaten

- Backventil är defekt

- Byt backventil

Blandare är trög

- Patron defekt, förkalkad

- Byt ut patron

Blandare droppar

- Patron defekt

- Byt ut patron

Varmvattentemperaturen är för låg

- Varmvattenreglering felaktigt inställd

- Ställ in varmvattenreglering

Varmvattenberedare slår ej på

- Vattenbegränsare i handduschen har ej tagits bort

- Ta bort vattenbegränsaren

- Smutsfiltren är igensmutsade

- Rengör / byt smutsfilter

- Backventil är defekt

- Byt backventil



Montering se sidan 46



Saugumo technikos nurodymai

- ⚠ Apsaugai nuo užspaudimo ir įsijovimo montavimo metu mūvėkite pirštines.
- ⚠ Gaminys turi būti naudojamas tik maudymuisi, kūno higienai ir švarai palaikyti.
- ⚠ Turi būti išlyginti šalto ir karšto slėgio nelygumai.

Montavimo instrukcija

- Prieš montuojant būtina patikrinti, ar gaminys nebuvo pažeistas transportavimo metu. Sumontavus pretenzijos dėl transportavimo ir paviršiaus pažeidimų nepriimamos.
- Maišytuvus privalo būti montuojamas ir išbandomas pagal veikiančias normas ir šią instrukciją.
- „Hansgrohe“ maišytuvai gali būti naudojami su hidrauliškai ir termiškai reguliuojamais momentiniais šildikliais, kai vandens slėgis mažesnis kaip 0,15 MPa.

Techniniai duomenys

Darbinis slėgis: ne daugiau kaip 1 MPa
 Rekomenduojamas slėgis: 0,1 – 0,5 MPa
 Bandomasis slėgis: 1,6 MPa
 (1 MPa = 10 barų = 147 PSI)
 Karšto vandens temperatūra: ne daugiau kaip 80 °C
 Rekomenduojama karšto vandens temperatūra: 65 °C
 Atstumas tarp centrų: 150 ± 12 mm
 Prijungimas G 1/2: Šaltas vanduo dešinėje, karštas - kairėje
 Terminis dezinfekavimas: ne daugiau kaip 70 °C / 4 min

Su atbuliniu vožtuvu

Produktas skirtas tik geriamajam vandeniui!

Simbolio aprašymas



Neaudokite silikono, kurio sudėtyje yra acto rūgšties!



Reguliavimas

Vienos rankenėlės maišytuvus turi karšto vandens ribotuvą (nustatymą žr. psl. 49). Naudojant momentinį šildiklį karšto vandens ribotuvus nebūtinai.

Gedimas

Per maža srovė

Priežastis

- Dušo galvos filtras užsikimšęs
- Abulinis vožtuvas neveikia

Priemonė

- Išvalyti dušo galvos filtrą
- Pakeisti atbulinį vožtuvą

Sunkiai sukiojama rankenėlė

- Kasetė pažeista, užkalkėjusi

- Pakeisti kasetę

Maišytuvus praleidžia vandenį

- Kasetė pažeista

- Pakeisti kasetę

Per maža karšto vandens temperatūra

- Neteisingai nustatytas karšto vandens ribotuvus

- Nustatyti karšto vandens ribotuvą

Momentinis pašildytojas neįsijungia

- Neišimtas ribotuvus iš dušo galvutės

- Išimti ribotuvą iš dušo galvutės

- Užsikimšęs filtras

- Išvalyti / pakeisti filtrą

- Abulinis vožtuvas neveikia

- Pakeisti atbulinį vožtuvą

**Techninis aptarnavimas** (žr. psl. 54)

Atbulinio vožtuvo apsauga privalo būti tikrinama reguliariai (mažiausiai kartą per metus pagal DIN 1988) pagal DIN EN1717 arba pagal galiojančias nacionalines arba regionines normas.

**Išmatavimai** (žr. psl. 50)**Pralaidumo diagrama** (žr. psl. 50)**Atsarginės dalys** (žr. psl. 52)**Eksplotacija** (žr. psl. 55)**Valymas**

žr. pridedamoje brošiūroje.

**Bandymo pažyma** (žr. psl. 56)**Sigurnosne upute**

- ⚠ Prilikom montaže se radi sprječavanja prignječenja i posjekotina moraju nositi rukavice.
- ⚠ Proizvod se smije primjenjivati samo za kupanje, tuširanje i osobnu higijenu.
- ⚠ Velika razlika u pritisku između vruće i hladne vode mora biti izbalansirana.

Upute za montažu

- Prije montaže mora se provjeriti je li proizvod oštećen prilikom transporta. Nakon ugradnje se ne priznaju nikakve reklamacije koje se odnose na površinska i transportna oštećenja.
- Cijevi moraju biti postavljene, isprane i testirane prema važećim normama.
- Hansgrohe armature mogu se koristiti u kombinaciji sa hidraulički i termički kontroliranim protočnim bojlerima ukoliko tlak iznosi najmanje 0,15 MPa

**Montavimas**
žr. psl. 46



Tehnički podatci

Najveći dopušteni tlak: tlak 1 MPa
 Preporučeni tlak: 0,1 – 0,5 MPa
 Probni tlak: 1,6 MPa
 (1 MPa = 10 bar = 147 PSI)
 Temperatura vruće vode: tlak 80 °C
 Preporučena temperatura vruće vode: 65 °C
 Razmak od sredine: 150 ± 12 mm
 Spojevi G 1/2: hladna desno – topla lijevo
 Termička dezinfekcija: tlak 70 °C / 4 min

Funkcije samo-čišćenja

Proizvod je koncipiran isključivo za pitku vodu!

Opis simbola



Nemojte koristiti silikon koji sadrži octenu kiselinu!



Regulacija

Da bi podesili limiter vruće vode na jednoručnim slavinama molimo Vas da pogledate stranicu 49. Podešavanje nije potrebno ako koristite protočni bojler.



Održavanje (pogledaj stranicu 54)

Ispravnost nepovratnog ventila mora se redovito provjeravati prema standardu DIN EN 1717 i u skladu sa važećim propisima (najmanje jednom godišnje).



Mjere (pogledaj stranicu 50)



Dijagram protoka (pogledaj stranicu 50)



Rezervni djelovi (pogledaj stranicu 52)



Upotreba (pogledaj stranicu 55)



Čišćenje

se u priloženoj brošuri.



Oznaka testiranja (pogledaj stranicu 56)

Greška

Uzrok

Otklanjanje

Nedovoljno vode

- Filter tuša je prljav
- Nepovratni ventil se nije vratio u početni položaj

- Očistite filter između tuša i crijeva
- Zamijenite nepovratni ventil

Ručica se zaglavila

- Neispravan uložak Taloženje kamenca

- Zamijenite uložak

Slavina kaplje

- Neispravan uložak

- Zamijenite uložak

Previsoka temperatura tople vode

- Limiter vruće vode nije dobro podešen

- Podesite limiter vruće vode

Protočni bojler ne radi

- Limiter protoka u ručnom tušu nije odstranjen
- Filtri su prljavi
- Nepovratni ventil se nije vratio u početni položaj

- Odstranite limiter protoka
- Očistite ili zamijenite filter
- Zamijenite nepovratni ventil



Sastavljanje pogledaj stranicu 46



⚠ Güvenlik uyarıları

- ⚠ Montaj esnasında ezilme ve kesilme gibi yaralanmaları önlemek için eldiven kullanılmalıdır.
- ⚠ Duş sistemi yalnızca banyo, hijyen ve beden temizliği amaçları doğrultusunda kullanılabilir.
- ⚠ Sıcak ve soğuk su bağlantıları arasında büyük basınç farklılıkları varsa, bu basınç farklılıklarının dengelenmesi gerekir.

Montaj açıklamaları

- Montaj işleminden önce ürün nakliye hasarları yönünden kontrol edilmelidir. Montaj işleminden sonra nakliye veya yüzey hasarları için sorumluluk üstlenilmemektedir.
- Batarya monte edilmeli, geçerli normlardan sonra akis testi yapılmalıdır.
- Hansgrohe bataryaları, akış basıncı en az 0,15 MPa olursa hidrolik ve termik kumandalı şofbenlerle bağlantılı olarak kullanılabilir.

Teknik bilgiler

İşletme basıncı:	azami 1 MPa
Tavsiye edilen işletme basıncı:	0,1 - 0,5 MPa
Kontrol basıncı:	1,6 MPa
(1 MPa = 10 bar = 147 PSI)	
Sıcak su sıcaklığı:	azami 80°C
Tavsiye edilen su ısı:	65°C
Bağlantı ölçüleri:	150 ± 12 mm
G 1/2 bağlantılar:	soğuk sağ - sıcak sol
Termik dezenfeksiyon:	azami 70°C / 4 dak

Geri emme önleyici

Ürün sadece şebeke suyu için tasarlanmıştır!

Simge açıklaması



Asetik asit içeren silikon kullanmayın!



Ayarlama

Sıcak su sınırlayıcı özelliğine sahip tek kollu bataryanın ayarlanması için 49. sayfaya bakınız. Bir sürekli akışlı su ısıtıcısı ile birlikte kullanılırsa sıcak su sınırlayıcısına gerek kalmaz.

arıza	sebebe	yardım
Az su geliyor	- Duşun süzgeci tıkanmış olabilir - Çek valf çalışmıyor olabilir	- El duşu ile hortum arasındaki hortumu yıkayın - Çek valfı değiştirin
Batarya kullanımı ağırlaşıyor	- Kartuş Bozulmuş ve kireçlenmiş olabilir	- Kartuşu değiştirin
Batarya su damlatıyor	- Kartuş bozuk olabilir	- Kartuşu değiştirin
Sıcak suyun derecesi çok düşük	- Isı limitleyici düzgün çalışmıyor	- Isı limitleyiciyi yeniden ayarlayın
Şofben çalışmıyor	- El duşunun içindeki akım limitleyici çıkartılmamış olabilir - Filtre tıkanmış olabilir - Çek valf çalışmıyor olabilir	- Akım limitleyiciyi el duşundan çıkartın - Filtreyi temizleyin yada çıkartın - Çek valfı değiştirin



Bakım (Bakınız sayfa 54)

DIN EN 1717 ve ulusal standartlar doğrultusunda Çek valfler düzenli olarak kontrol edilmelidir. (en az yılda bir kez)



Ölçüleri (Bakınız sayfa 50)



Akış diyagramı (Bakınız sayfa 50)



Yedek Parçalar (Bakınız sayfa 52)



Kullanımı (Bakınız sayfa 55)



Temizleme

birlikte verilen broşür.



Kontrol işareti (Bakınız sayfa 56)



Instrucțiuni de siguranță

- ⚠ La montare utilizați mănuși pentru evitarea contuziunilor și tăierii mâinilor.
- ⚠ Sistemul de duș poate fi utilizat doar pentru spălarea, menținerea igienei și curățarea corpului.
- ⚠ Diferențele de presiune mari între alimentarea cu apă rece și apă caldă trebuie echilibrate.

Instrucțiuni de montare

- Înainte de instalare verificați, dacă produsul prezintă deteriorări de transport. După instalare garanția nu acoperă deteriorările de transport și cele de suprafață.
- Bateria trebuie montată, clătită și verificată conform normelor în vigoare.
- Bateriile Hansgrohe pot fi utilizate cu boiler instant cu comandă termică sau hidraulică dacă presiunea apei de alimentare este de min. 0,15 MPa.





Date tehnice

Presiune de funcționare: max. 1 MPa
 Presiune de funcționare recomandată: 0,1 – 0,5 MPa
 Presiune de verificare: 1,6 MPa
 (1 MPa = 10 bar = 147 PSI)
 Temperatura apei calde: max. 80 °C
 Temperatura recomandată a apei calde: 65 °C
 Interax racorduri: 150 ± 12 mm
 Racorduri G ½ : rece - dreapta / cald - stânga
 Dezinfecție termică: max. 70 °C / 4 min

Asigurat contra scurgere înapoi

Produsul este destinat exclusiv pentru apă potabilă.

Descrierea simbolurilor



Nu utilizați silicon cu conținut de acid acetic!



Reglare

Bateria monocomadă cu limitarea apei calde, pentru reglare vezi pag. 49. Dacă conectați bateria la un boiler instant nu este necesară instalarea unui opritor de apă caldă.



Întreținere (vezi pag. 54)

Supapele de reținere trebuie verificate regulat conform DIN EN 1717 și standardele naționale sau regionale (anual conform DIN 1988).



Dimensiuni (vezi pag. 50)



Diagrama de debit

(vezi pag. 50)



Piese de schimb (vezi pag. 52)



Utilizare (vezi pag. 55)



Curățare

vezi broșura alăturată.



Certificat de testare (vezi pag. 56)

Deranjament

Cauza

Măsuri de remediere

Prea puțină apă

- S-a murdărit garnitura de sită a capătului de duș.

- Curățați garnitura sită dintre capătul duș și furtun.

- S-a blocat supapa antifretur.

- Schimbați supapa antifretur.

Bateria se mișcă dificil

- Cartuș defect din cauza depunerilor de calcar

- Schimbați cartușul.

Bateria picură

- Cartuș defect

- Schimbați cartușul.

Temperatura apei calde este prea mică

- Limitarea temperaturii apei calde setată incorect.

- Setează limitarea temperaturii apei calde.

Boilerul instant nu funcționează.

- Reductorul nu a fost demontat din dușul de mână.

- Îndepărtați reductorul din dușul de mână.

- Sitele de impurități murdare.

- Curățați / schimbați sitele de impurități.

- S-a blocat supapa antifretur.

- Schimbați supapa antifretur.



Montare vezi pag. 46



Υποδείξεις ασφαλείας

- ⚠ Για να αποφύγετε τραυματισμούς κατά τη συναρμολόγηση πρέπει να φοράτε γάντια.
- ⚠ Το προϊόν επιτρέπεται να χρησιμοποιείται μόνο σαν μέσο λουτρού, υγιεινής και καθαρισμού του σώματος.
- ⚠ Οι διαφορές της πίεσης μεταξύ της σύνδεσης κρύου και ζεστού νερού θα πρέπει να αντισταθμίζονται.

Οδηγίες συναρμολόγησης

- Πριν τη συναρμολόγηση πρέπει να εξεταστεί το προϊόν για ζημιές μεταφοράς. Μετά την εγκατάσταση δεν αναγνωρίζονται ζημιές από τη μεταφορά ή επιφανειακές ζημιές.
- Η μπαταρία πρέπει να τοποθετηθεί, να πλυθεί και να ελεγχθεί με βάση τους ισχύοντες κανόνες υδραυλικής τέχνης
- Οι βάνες Hansgrohe μπορούν να συνδυαστούν με ταχυθερμοσίφωνες υδραυλικού και θερμικού ελέγχου, όταν η πίεση ροής αριθμεί τουλάχιστον 0,15 MPa.

Τεχνικά Χαρακτηριστικά

Λειτουργία πίεσης:	έως 1 MPa
Συνιστώμενη λειτουργία πίεσης:	0,1 – 0,5 MPa
Πίεση ελέγχου:	1,6 MPa
(1 MPa = 10 bar = 147 PSI)	
Θερμοκρασία ζεστού νερού:	έως 80 °C
Συνιστώμενη θερμοκρασία ζεστού νερού:	65 °C
Διαστάσεις σύνδεσης:	150 ± 12 mm
Συνδέσεις G 1/2:	κρύο δεξιά – ζεστό αριστερά
Θερμική απολύμανση:	έως 70 °C / 4 min

Περιλαμβάνει βαλβίδα αντεπιστροφής.

Το προϊόν έχει σχεδιαστεί αποκλειστικά για πόσιμο νερό!

Περιγραφή συμβόλων



Μην χρησιμοποιείτε σιλικόνη που περιέχει οξικό οξύ!



Ρύθμιση

Για να προσαρμόσετε το δοσομετρητή ζεστού νερού σε αναμεικτικές μπαταρίες, παρακαλούμε δείτε τη ρύθμιση στη σελ. 49. Δεν είναι απαραίτητη η διάταξη φραγής ζεστού νερού σε συνδυασμό με ταχυθερμοσίφωνα.

Βλάβη

Αιτία

Διόρθωση

Ανεπαρκές νερό

- Βρώμικη στεγανοποιητική σήτα του καταιονιστήρα

- Καθαρίστε και, εάν χρειαστεί, αλλάξτε τη στεγανοποιητική σήτα μεταξύ καταιονιστήρα και σπιράλ

- Η βαλβίδα αντεπιστροφής δεν γυρίζει πίσω.

- Αλλάξτε τη βαλβίδα αντεπιστροφής

Σκληρή μπαταρία (μείκτης)

- Ελαττωματικό φυσιγγίο, άλατα

- Αλλαγή φυσιγγίου

Η μπαταρία σιάζει

- Ελαττωματικό φυσιγγίο

- Αλλαγή φυσιγγίου

Χαμηλή θερμοκρασία ζεστού νερού

- Λάθος ρύθμιση της περιοριστικής διάταξης ζεστού νερού

- Ρυθμίστε την περιοριστική διάταξη του ζεστού νερού

Ο ταχυθερμοσίφοντας δεν ενεργοποιείται

- Το στραγγαλιστικό πηνίο δεν έχει αποσυναρμολογηθεί από τον καταιονιστήρα χειρός

- Καθαρίστε το στραγγαλιστικό πηνίο από τον καταιονιστήρα χειρός

- Τα φίλτρα συλλογής ακαθαρσιών είναι λερωμένα

- Καθαρίστε/αλλάξτε το φίλτρο συλλογής ακαθαρσιών

- Η βαλβίδα αντεπιστροφής δεν γυρίζει πίσω.

- Αλλάξτε τη βαλβίδα αντεπιστροφής

**Συντήρηση** (βλ. σελίδα 54)

Οι βαλβίδες αντεπιστροφής πρέπει να ελέγχονται τακτικά ως προς τη λειτουργία τους, σύμφωνα με τις οδηγίες DIN EN 1717, σε σχέση με τους ισχύοντες εθνικούς ή τοπικούς κανόνες (το ελάχιστο μια φορά το χρόνο, σύμφωνα με το πρότυπο DIN 1988)

**Διαστάσεις** (βλ. σελίδα 50)**Διάγραμμα ροής**
(βλ. σελίδα 50)**Ανταλλακτικά** (βλ. σελίδα 52)**Χειρισμός** (βλ. σελίδα 55)**Καθαρισμός**

βλ. συνημμένο φυλλάδιο.

**Σήμα ελέγχου** (βλ. σελίδα 56)**Varnostna opozorila**

- ⚠️ Pri montaži je treba nositi rokavice, da se preprečijo poškodbe zaradi zmečkanja ali urezov.
- ⚠️ Ta izdelek se sme uporabljati le z namenom umivanja, vzdrževanja higiene in telesne nege.
- ⚠️ Velike razlike v tlaku med priključkom za mrzlo in priključkom za toplo vodo je potrebno izravnati.

Instructions pour le montage

- Pred montažo je treba izdelek preveriti glede morebitnih transportnih poškodb. Po vgradnji transportne ali površinske poškodbe ne bodo več priznane.
- Armature je potrebno montirati, splakniti in testirati v skladu z veljavnimi predpisi.
- Armature Hansgrohe lahko uporabljate v povezavi s hidravlično in termično uravnavanimi pretočnimi grelniki, če je pretočni tlak najmanj 0,15 MPa.

**Συναρμολόγηση**
βλ. σελίδα 46



Tehnični podatki

Delovni tlak:	maks. 1 MPa
Priporočeni delovni tlak:	0,1 – 0,5 MPa
Preskusni tlak:	1,6 MPa
(1 MPa = 10 bar = 147 PSI)	
Temperatura tople vode:	maks. 80 °C
Priporočena temperatura tople vode:	65 °C
Razdalja od sredine:	150 ± 12 mm
Priključki G 1/2:	mrzla desno - topla levo
Termična dezinfekcija:	maks. 70 °C / 4 min

Zaščita proti povratnemu toku

Proizvod je zasnovan izključno za sanitarno vodo!

Opis simbola



Ne smete uporabiti silikona, ki vsebuje ocetno kislino!



Justiranje

Enoročne mešalne baterije z omejevalnikom tople vode, za justiranje glejte stran 49. V povezavi s pretočnimi grelniki zapora tople vode ni potrebna.



Vzdrževanje (glejte stran 54)

Delovanje protipovratnega ventila je potrebno v skladu z DIN EN 1717 in skladno z državnimi in regionalnimi določili (DIN 1988 enkrat letno) redno testirati.



Mere (glejte stran 50)



Diagram pretoka (glejte stran 50)



Rezervni deli (glejte stran 52)



Upravljanje (glejte stran 55)



Čiščenje

glejte priloženi brošuri.



Preskusni znak (glejte stran 56)

Napaka

Malo vode

Vzrok

- Filtrirna mrežica prhe je umazana

Pomoč

- Očistite filtrirno mrežico med prho in gibko cevjo

Težko premikanje armature

- Pokvarjen vložek, poapneno

- Zamenjajte protipovratni ventil

Iz armature kaplja

- Pokvarjen vložek

- Zamenjajte vložek

Pre nizka temperatura tople vode

- Omejevalnik tople vode ni pravilno nastavljen

- Nastavite omejevalnik tople vode

Pretočni grelnik se ne vklopi

- Omejevalnik pretoka ni odstranjen iz ročne prhe

- Odstranite omejevalnik pretoka iz ročne prhe

- Filtri so umazani

- Očistite/zamenjajte filtre

- Protipovratni ventil je obtičal

- Zamenjajte protipovratni ventil



Montaža

Glejte stran 46.



Ohutusjuhised

- ⚠ Kandke paigaldamisel muljumis- ja löikevigastuste vältimiseks kindaid.
- ⚠ Toodet tohib kasutada ainult pesemis-, hügieeni- ja kehapuhastamisesmärkidel.
- ⚠ Kui külma ja kuuma vee ühenduste surve on väga erinev, tuleb need tasakaalustada.

Paigaldamisjuhised

- Enne paigaldamist tuleb toodet kontrollida transpordikahjustuste osas. Pärast paigaldamist ei tunnustata enam transpordi- või pinnakahjustuste kaebuseid.
- Seadmestiku paigaldamine, läbipesu ja kontrollimine peab toimuma vastavalt kehtivatele normidele.
- Hansgrohe segisteid võib kasutada koos hüdrauliliselt ja termiliselt juhitavate boileritega, kui vee surve on vähemalt 0,15 MPa.

Tehnilised andmed

Töörõhk	maks. 1 MPa
Soovitav töörõhk:	0,1 – 0,5 MPa
Kontrollsurve:	1,6 MPa
(1 MPa = 10 baari = 147 PSI)	
Kuuma vee temperatuur:	maks. 80 °C
Soovitav kuuma vee temperatuur:	65 °C
distsants keskelt:	150 ± 12 mm
ühendused G 1/2:	külm paremal, kuum vasakul
Termiline desinfitseerimine:	maks. 70 °C / 4 min

tagasivooluklapp

Toode on ette nähtud eranditult joogivee jaoks!

Sümbolite kirjeldus



Ärge kasutage äädikhapet sisaldavat silikooni!



Reguleerimine

Ühe juhtkangiga segisti kuuma vee piiraja reguleerimise kohta vt lk 49. Läbivoolu boilerite puhul pole reguleerimine vajalik.

Rike	Põhjus	Lahendus
Vähe vett	- Duši sõeltihend must - Tagasilöögiklapp on kinni	- Puhastage duši ja vooliku vaheline sõeltihend - Tagasilöögiklapp välja vahetada
Segisti käib raskelt	- Tööelement on katkine, lubjastunud	- Vahetage tööelement
Segisti tilgub	- Tööelement on katkine	- Zamenjajte vložek
Sooja vee temperatuur liiga madal	- Kuuma vee piirang valesti seatud	- Seadke kuuma vee piirang
avatud süsteemi boiler ei lülitu sisse	- Veehulga piiraja ei ole ära võetud - Filtrid määrdunud - Tagasilöögiklapp on kinni	- Eemaldage veehulga piiraja - Puhastage/vahetage filter - Tagasilöögiklapp välja vahetada



Hooldus (vt lk 54)

Tagasilöögiklappide toimimist tuleb kooskõlas riiklike ja regionaalsete määrustega regulaarselt kontrollida vastavalt standardile DIN EN 1717 (DIN 1988 - kord aastas).



Mõõtude (vt lk 50)



Läbivooludiagramm

(vt lk 50)



Varuosad (vt lk 52)



Kasutamine (vt lk 55)



Puhastamine

vt kaasasolevast brošüürist.



Kontrollsertifikaat (vt lk 56)



Drošības norādes

- ⚠ Montāžas laikā, lai izvairītos no saspiedumiem un iegriezumiem, nepieciešams nēsāt cimdus.
- ⚠ Šo produktu drīkst izmantot tikai, lai mazgātos, higiēnai un ķermeņa tīrīšanai.
- ⚠ Jāizlīdzina spiediena atšķirības starp aukstā un karstā ūdens pievadiem.

Norādījumi montāžai

- Pirms montāžas nepieciešams pārbaudīt, vai produktam transportēšanas laikā nav radušies bojājumi. Pēc iebūvēšanas bojājumi, kas radušies transportēšanas laikā, vai virsmas bojājumi netiek atzīti.
- Jaucējkrāns jāmontē, jāskalo un jāpārbauda atbilstoši spēkā esošajām normām.
- Hansgrohe jaucējkrānus var izmantot kombinācijā ar hidrauliski un termiski vadāmiem caurteces sildītājiem, ja plūsmas spiediens ir vismaz 0,15 MPa.





Tehniskie dati

Darba spiediens:	maks. 1 MPa
Ieteicamais darba spiediens:	0,1 – 0,5 MPa
Pārbaudes spiediens:	1,6 MPa
(1 MPa = 10 bar = 147 PSI)	
Karstā ūdens temperatūra:	maks. 80 °C
Ieteicamā karstā ūdens temperatūra:	65 °C
Pieslēguma izmēri:	150 ± 12 mm
G 1/2 pieslēgumi:	aukstsais pa labi - karstsais pa kreisi
Termiskā dezinfekcija:	maks. 70 °C / 4 min

Drošības vārsts

Izstrādājums ir paredzēts tikai dzeramajam ūdenim!

Simbolu nozīme



Neizmantojot silikonu, kas satur etiķskābi!



Ieregulēšana

Viensvīras jāucējkrāns ar siltā ūdens ierobežošanu, ieregulēšanu skat. 49. lpp.
Kombinācijā ar caurteces sildītāju karstā ūdens ierobežošana nav nepieciešama.



Apkope (skat. 54. lpp.)

Regulāri jāpārbauda pretvārsta funkcija saskaņā ar DIN EN 1717 saistībā ar nacionālajiem vai vietējiem noteikumiem (DIN 1988 vienreiz gadā).



Izmērus (skat. 50. lpp.)



Caurplūdes diagramma (skat. 50. lpp.)



Rezerves daļas (skat. 52. lpp.)



Lietošana (skat. 55. lpp.)



Tīrīšana

skatiet pievienotajā brošūrā.



Pārbaudes zīme (skat. 56. lpp.)

Traucējums

Maz ūdens

Iemesls

- Netīrs dušas filtra blīvējums

Bojājumu novēršana

- Izītīt filtra blīvējumu starp dušu un šūteni

Jaucējkrāns smagi grozāms

- Pretvārsts ir iesprūdis

- Nomainīt pretvārstu

Jaucējkrāns pil

- Bojāta kartuša, aizkaļķojusies

- Nomainīt kartušu

Pārāk zema ūdens temperatūra

- Bojāta kartuša

- Nomainīt kartušu

Neieslēdzas caurteces sildītājs

- Nepareizi noregulāta karstā ūdens bloķēšana

- Noregulēt karstā ūdens ierobežošanu

- Rokas dušā nav demontēts vārsts

- Izņemt no rokas dušas vārstu

- Filtri netīri

- Tīrīt / nomainīt filtrus

- Pretvārsts ir iesprūdis



- Nomainīt pretvārstu



Montāža skat. 46. lpp.



Sigurnosne napomene

-  Prilikom montaže se radi sprečavanja prignječenja i posekotina moraju nositi rukavice.
-  Proizvod sme da se koristi samo za kupanje, tuširanje i ličnu higijenu.
-  Velika razlika u pritisku između vruće i hladne vode mora biti izbalansirana.

Instrukcije za montažu

- Pre montaže se mora proveriti da li je proizvod oštećen pri transportu. Nakon ugradnje se ne priznaju nikakve reklamacije koje se odnose na površinska i transportna oštećenja.
- Armatura mora biti postavljena, isprana i testirana prema važećim normama.
- Hansgrohe armature se mogu koristiti u kombinaciji s hidraulički i termički kontrolisanim protočnim bojlerima ukoliko pritisak iznosi najmanje 0,15 MPa.

Tehnički podaci

Radni pritisak:	maks. 1 MPa
Preporučeni radni pritisak:	0,1 – 0,5 MPa
Probni pritisak:	1,6 MPa
(1 MPa = 10 bar = 147 PSI)	
Temperatura vruće vode:	maks. 80°C
Preporučena temperatura vruće vode:	65°C
Rastojanje između centara priključaka:	150 ± 12 mm
Priključci G 1/2:	hladna voda desno – topla levo
Termička dezinfekcija:	maks. 70°C / 4 min

Zaštita od povratnog toka

Proizvod je koncipiran isključivo za pijaću vodu!

Opis simbola



Nemojte koristiti silikon koji sadrži sirćetnu kiselinu!



Podešavanje

Da bi ste podesili ograničavač vruće vode na jednoručnim mešačima, molimo Vas da pogledate stranicu 49. Podešavanje nije potrebno ako koristite protočni bojler.

Smetnja	Uzrok	Pomoć
Nedovoljno vode	- Mrežasta zaptivka tuša je prljava - Nepovratni ventil se nije vratio u početni položaj	- Očistite mrežastu zaptivku između tuša i crijeva - Zamenite nepovratni ventil
Ručica se zaglavila	- Neispravna kartuša, nataloženi kamenac	- Zamenite kartušu
Slavina kaplje	- Neispravna kartuša	- Zamenite kartušu
Preniska temperatura tople vode	- Ograničavač vruće vode nije dobro podešen	- Podesite ograničavač vruće vode
Protočni bojler ne radi	- Prigušnica u ručnom tušu nije odstranjena - Mrežice za hvatanje prljavštine su prljave - Nepovratni ventil se nije vratio u početni položaj	- Odstranite prigušnicu iz ručnog tuša - Očistite / zamenite mrežicu za hvatanje prljavštine - Zamenite nepovratni ventil

**Održavanje** (vidi stranu 54)

Ispravno funkcionisanje nepovratnog ventila se mora redovno proveravati prema standardu DIN EN 1717 i u skladu s važećim nacionalnim ili regionalnim propisima (DIN 1988 jednom godišnje).

**Mere** (vidi stranu 50)**Dijagram protoka**
(vidi stranu 50)**Rezervni delovi** (vidi stranu 52)**Rukovanje** (vidi stranu 55)**Čišćenje**

vidi priloženoj brošuri.

**Ispitni znak** (vidi stranu 56)**Sikkerhetshenvisninger**

- ⚠ Bruk hansker under montasjen for å unngå klem- og kuttskader.
- ⚠ Dusjsystemet skal kun brukes for bade-, hygiene- og kroppshygiene.
- ⚠ Store trykkdifferanser mellom kaldt- og varmtvannstilkoblinger skal utlignes.

Montagehenvisninger

- Før montasjen skal produktet sjekkes for transportskader. Etter monteringen aksepteres ikke noen transport- eller overflateskader.
- Armaturen skal monteres, spyles og sjekkes iht. gyldige standarder.
- Armaturer fra Hansgrohe kan brukes sammen med hydraulisk og termisk styrte gjennomstrømningsovner når gjennomstrømningstrykket er på minst 0,15 MPa.

**Montaža**
vidi stranu 46



Tekniske data

Driftstrykk	maks. 1 MPa
Anbefalt driftstrykk:	0,1 - 0,5 MPa
Prøvetrykk	1,6 MPa
(1 MPa = 10 bar = 147 PSI)	
Varmtvannstemperatur	maks. 80 °C
Anbefalt temperatur for varmt vann	65 °C
Tilkoblingsmål:	150 ± 12 mm
Tilkoblinger G 1/2	kaldt høyre - varm venstre
Termisk desinfisering:	maks. 70 °C / 4 min

Egensikker mot tilbakeflyt

Produktet er utelukkende designet for drikkevann!

Symbolbeskrivelse



Ikke bruk silikon som inneholder eddiksyre!



Justering

Enhåndblande batteri med varmtvannsbegrensning. For justering se side 49. I forbindelse med en gjennomstrømningsovn er det ikke nødvendig med varmtvannsbegrensning.



Vedlikehold (se side 54)

Funksjonen til returløpssperren skal iht. DIN EN 1717 og i samsvar med de nasjonale og lokale forskrifter sjekkes regelmessig (DIN 1988 en gang i året).



Mål (se side 50)



Gjennomstrømningsdiagram (se side 50)



Service deler (se side 52)



Betjening (se side 55)



Rengjøring

se vedlagt brosjyre.



Prøvemerket (se side 56)



Feil	Årsak	Feilrettelse
Lite vann	- Dusjens silpakning er skitten - Returløpstopper sitter fast	- Silpakning mellom dusj og slangen rengjøres - Returløpstopper byttes
Armatyr ikke lett bevegelig	- Kartusj defekt, forkalkning	- Kartusj byttes
Armatyr drypper	- Kartusj defekt	- Kartusj byttes
For lav varmtvannstemperatur	- Varmtvannsbegrensning er feil innstilt	- Varmtvannsbegrensning innstilles
Gjennomstrømningsovn innkobler ikke.	- Drossel til hånddusjen ikke fjernet - Smussfangersil skitten - Returløpstopper sitter fast	- Drossel fjernes fra hånddusjen - Smussfangersil rengjøres / byttes - Returløpstopper byttes



Montasje se side 46



Указания за безопасност

-  При монтажа трябва да се носят ръкавици, за да се избегнат наранявания поради притискане или порязване.
-  Позволено е използването на продукта само за къпане, хигиена и цели на почистване на тялото.
-  Големите разлики в налягането между изводите за студената и топлата вода трябва да се изравняват.

Указания за монтаж

- Преди монтажа продуктът трябва да се провери за транспортни щети. След монтажа не се признават транспортни или повърхностни щети.
- Арматурата трябва да се монтира, промие и провери в съответствие с валидните норми.
- Арматурите на Hansgrohe могат да се използват във връзка с хидравлично и термично управляеми проточни нагреватели, ако хидравличното налягане е минимум 0,15 МПа.

Технически данни

Работно налягане:	макс. 1 МПа
Препоръчително работно налягане:	0,1 – 0,5 МПа
Контролно налягане:	1,6 МПа
(1 МПа = 10 bar = 147 PSI)	
Температура на горещата вода:	макс. 80°C
Препоръчителна температура на горещата вода:	65°C
Присъединителни размери:	150 ± 12 mm
Изводи G 1/2:	студено отцясно – топло отляво
Термична дезинфекция:	макс. 70°C / 4 мин

Самозащитен против обратно изтичане

Продуктът е разработен само за питейна вода!

Описание на символите



Не използвайте силикон, съдържащ оцетна киселина!



Юстиране

Смесител с една ръкохватка с ограничител за топлата вода, юстирането вижте на стр. 49. Във връзка с проточни нагреватели не е необходима блокировка за топлата вода.

Неизправност

Причина

Помощ

Малко вода	- Замърсено е уплътнението с цедка на разпръсквателя - Здравно стоящо приспособление за предотвратяване на обратния поток	- Почистете уплътнението с цедка между разпръсквателя и маркуча - Смяна на приспособлението за предотвратяване на обратния поток
Трудно подвижна арматура	- Дефектна гилза, покрита с варовик	- Сменете гилзата
Арматурата капе	- Дефектна гилза	- Сменете гилзата
Твърде ниска температура на водата	- Ограничението за топлата вода е грушно настроена	- Настройте ограничението за топлата вода
Проточният нагревател не се включва	- Дроселът в ръчния разпръсквател не е демонтиран - Цедките за улавяне на замърсяванията са замърсени - Здравно стоящо приспособление за предотвратяване на обратния поток	- Отстранете дросела от ръчния разпръсквател - Почистете / сменете цедките за улавяне на замърсяванията - Смяна на приспособлението за предотвратяване на обратния поток



Поддръжка (вижте стр. 54)

Съгласно DIN EN 1717 редовно трябва да се проверява функционирането на приспособленията за предотвратяване на обратния поток в съответствие с националните или регионални изисквания (DIN 1988 веднъж годишно).



Размери (вижте стр. 50)



Диаграма на потока (вижте стр. 50)



Сервизни части (вижте стр. 52)



Обслужване (вижте стр. 55)



Почистване

от приложената брошура.



Контролен знак (вижте стр. 56)



Udhëzime sigurie

- ⚠ Пër të evituar lëndimet e pickimeve ose të prerjeve gjatë procesit të montimit duhet që të vishni doreza.
- ⚠ Produkti duhet të përdoret vetëm qëllimet e banjave, të higjienës dhe të larjes së trupit.
- ⚠ Ndryshimet e mëdha të presionit mes lidhjeve të ujit të ftohtë dhe atij të ngrohtë duhen ekuilibruar.

Udhëzime për montimin

- Përpara montimit duhet që produkti të kontrollohet për dëmtime nga transporti. Pas instalimit nuk do të njihet asnjë dëmtim nga transporti ose dëmtim i sipërfaqes.
- Armatura duhet montuar, shpërlarë dhe kontrolluar në bazë të normave të vlefshme.
- Armaturat e Hansgrohe mund të përdoren në kombinim me ngrohës elektrikë të ujit të drejtuar në mënyrë hidraulike ose termike nëse presioni i rrjedhjes është minimumi 0,15 MPa.



Монтаж

вижте стр. 46



Të dhëna teknike

Presioni gjatë punës	maks. 1 MPa
Presioni i rekomanduar:	0,1 – 0,5 MPa
Presioni për provë:	1,6 MPa
(1 MPa = 10 bar = 147 PSI)	
Temperatura e ujit të ngrohtë	maks. 80 °C
Temperatura e rekomanduar e ujit të ngrohtë:	65 °C
Përmasat e lidhjeve:	150 ± 12 mm
Lidhjet G 1/2:	i ftohtë djathtas - i ngrohtë majtas
Dezinfektim Termik:	maks. 70 °C / 4 min

Siguresa kundër rrjedhjes në drejtim të kundërt
Produkti është projektuar ekskluzivisht për ujë të pijshëm!

Përshkrimi i simbolit



Mos përdorni silikon që në përbërje ka acid acetik.



Justimi

Rubinet me ujë të përzier me kufizim të ujit të ngrohtë, justimi shih faqen 49. Në kombinim me ngrohësit elektrikë të ujit nuk ka nevojë për bllokadë të ujit të ngrohtë.



Mirëmbajtja (shih faqen 54)

Penguesit e rrjedhjes në drejtim të kundërt duhen kontrolluar rregullisht në bazë të normave DIN EN 1717 konform normave nacionale dhe regionale (DIN 1988 një herë në vit).



Përmasat (shih faqen 50)



Diagrami i qarkullimit (shih faqen 50)



Pjesë ndërrimi (shih faqen 52)



Përdorimi (shih faqen 55)



Pastrimi

shikoni broshurën bashkëngjitur.



Shenja e kontrollit (shih faqen 56)

Demtim

Pak ujë

Shkaku

- Gomina hermetizuese e pajisjes me papasteriti
- Penguesi i rrjedhjes mbrapsht te ujit qendron i fiksuar

Ndihme

- Pastroni gominen e sites midis pajisjes dhe tubit
- Kembeni pernguesin e rrjedhjes mbrapsht te ujit

Armatura punon rende

- Kartusha me defekt, me kalk

- Kembeni kartushen

Armatura pikon

- Kartusha me defekt

- Kembeni kartushen

Temperaturë e ulët e ujit të ngrohtë

- Kufiri i ujit te ngrohte eshte regjistruar gabim

- Regjistroni kufirin e ujit te ngrohte

Ngrohësi i ujit nuk ndizet.

- Rregulluesi i ujit në tubacione nuk është i hequr nga spërkatësja
- Sita që mbledh papasteritë është e piset
- Penguesi i rrjedhjes mbrapsht te ujit qendron i fiksuar

- Hiqni rregulluesin e ujit në tubacione nga spërkatësja
- Pastroni/Kembeni siten që mbledh papasteritë
- Kembeni pernguesin e rrjedhjes mbrapsht te ujit



Montimi shih faqen 46



وصف الرمز

هام! لا تستخدم السليكون الذي يحتوي على أحماض!



الضبط

لضبط محدد الماء الساخن في الخلاطات ذات المقبض الواحد، يرجى الرجوع إلى صفحة 49. ولا يلزم إجراء أي ضبط عند استخدام سخان مياه ذي تدفق مستمر.



الصيانة (راجع صفحة 54)

يجب فحص صمام عدم الرجوع بصفة منتظمة حسب المواصفة DIN EN 1717 وذلك طبقاً للوائح الوطنية أو الإقليمية (مرة واحد سنوياً طبقاً للمواصفة DIN 1988).



أبعاد (راجع صفحة 50)

رسم للصرف

(راجع صفحة 50)

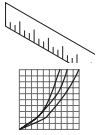

قطع الغيار (راجع صفحة 52)



التشغيل (راجع صفحة 55)

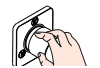

التنظيف

راجع والكتيب المرفق.



شهادة اختبار (راجع صفحة 56)





المواصفات الفنية

الحد الأقصى 1 ميجاباسكال
 ضغط التشغيل: 0,1 – 0,5 ميجاباسكال
 ضغط التشغيل الموصى به: 1,6 ميجاباسكال
 ضغط الاختبار: (1 ميجاباسكال = 10 بار = 147 PSI)
 درجة حرارة الماء الساخن: الحد الأقصى 80°C
 درجة الحرارة الموصى بها للماء الساخن: 65°C
 المسافة المركزية: 150 ± 12 mm
 الوصلات: 1/2" G الماء البارد جهة اليمين - الماء الساخن جهة اليسار
 تعقيم حراري: الحد الأقصى 4 / 70°C الدقيقة

خاصية عدم التدفق العكسي

المنتج مخصص فقط لماء الشرب!

تنبيهات الأمان

- ⚠ يجب ارتداء قفازات لليد أثناء التركيب لتجنب حدوث أضرار الإنحشار أو الجروح.
- ⚠ لا يجب استخدام نظام الدش إلا في أغراض الاستحمام والأغراض الصحية وأغراض تنظيف الجسم.
- ⚠ يجب أن يكون تيار الماء الساخن والماء البارد متعادلين في الضغط.

تعليمات التركيب

- قبل القيام بعملية التركيب، يجب فحص المنتج للتأكد من خلوه من أية تلفيات ناتجة عن النقل. بعد القيام بعملية التركيب، لن يتم الاعتراف بوجود أية تلفيات سطحية أو تلفيات ناتجة عن عملية النقل.
- يجب تركيب الوصلة واستخدامها واختبارها وفقاً للمعايير المعمول بها.
- يمكن استخدام خلطات هانزجروهي مع سخانات تدفق الماء ذات التحكم الهيدروليكي والحراري، مع ضغط تدفق لا يقل عن 0,15 ميجاباسكال.

العلاج والإصلاح

السبب

المطل

الماء غير كافٍ	- سداة مصفاة الدش متسخة	- نظف سداة المصفاة بين الدش والخرطوم
	- صمام منع الرجوع ثابت ولا يتحرك	- قم بتغيير صمام منع الرجوع
الخلط ثقيل الحركة	- الخرطوشة تالفة، تراكم عليها الجير	- قم بتغيير الخرطوشة
تساقط قطرات مياه من الخلاط	- الخرطوشة تالفة	- قم بتغيير الخرطوشة
درجة حرارة الماء الساخن منخفضة للغاية	- محدد الماء الساخن مضبوط بشكل خاطيء	- قم بضبط محدد الماء الساخن
السخان الفوري لا يعمل	- محدد التدفق غير مخلوع من الدش	- انزع محدد التدفق من الدش
	- الفلتر متسخ	- قم بتنظيف / تغيير الفلتر
	- صمام منع الرجوع ثابت ولا يتحرك	- قم بتغيير صمام منع الرجوع

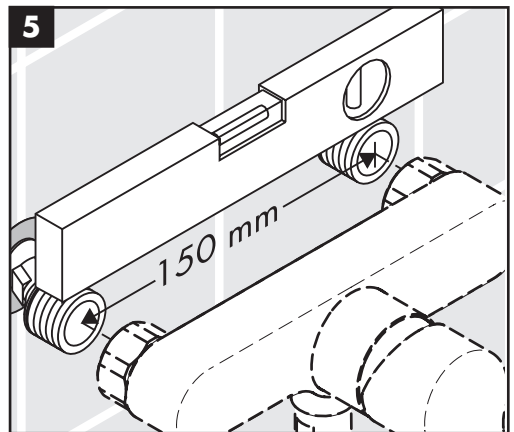
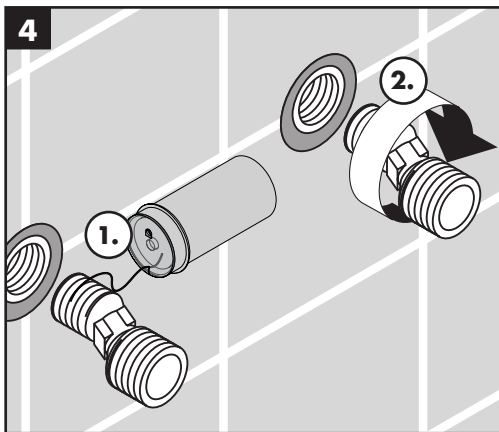
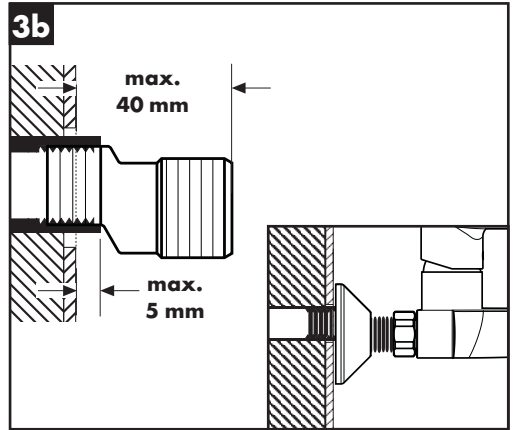
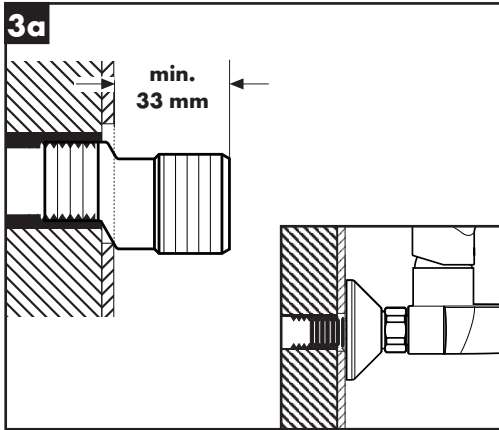
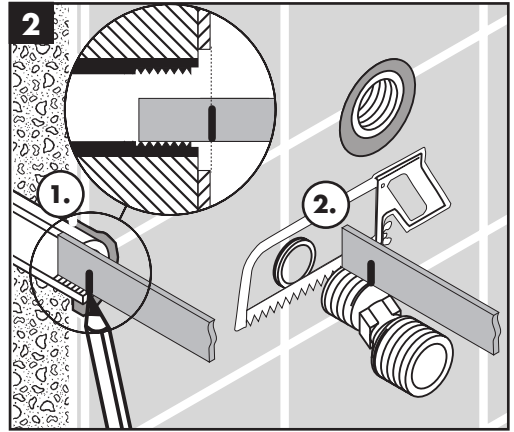
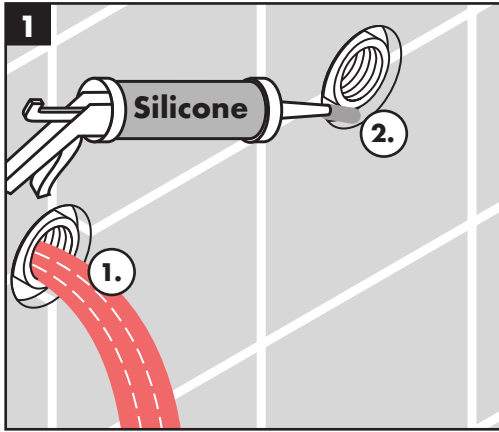

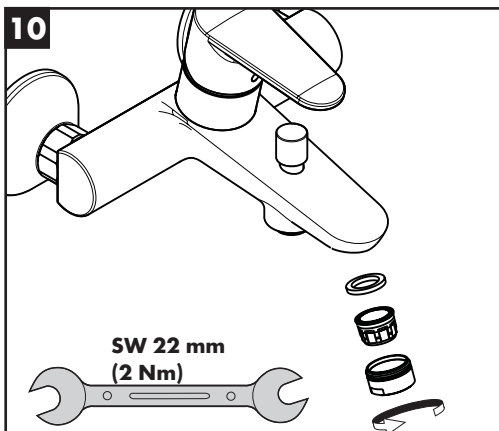
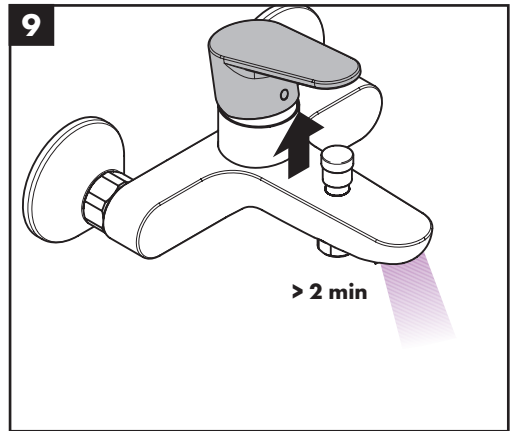
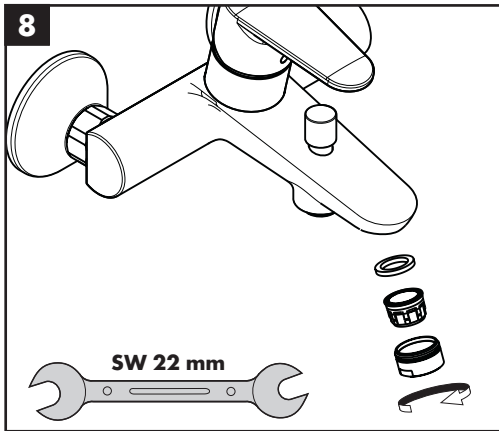
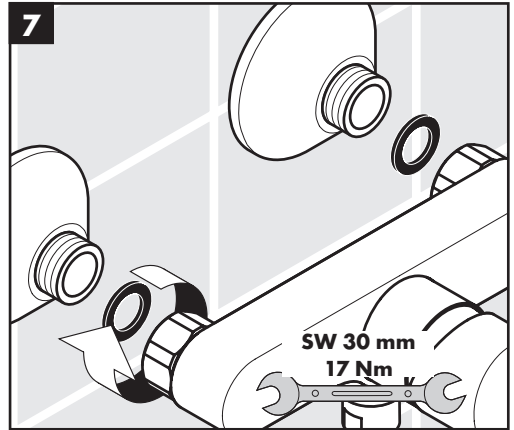
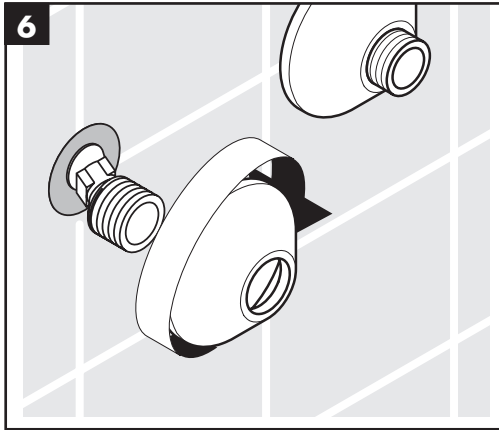

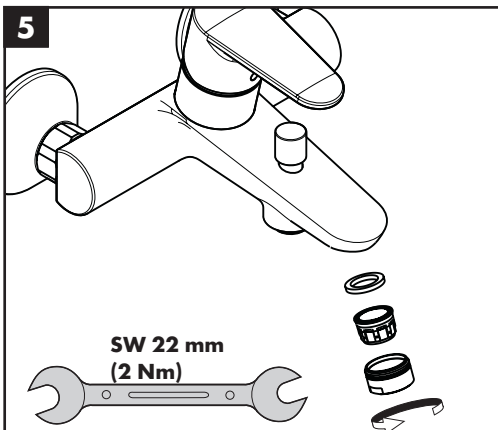
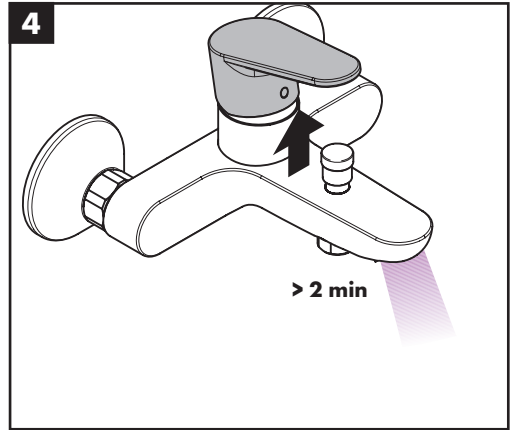
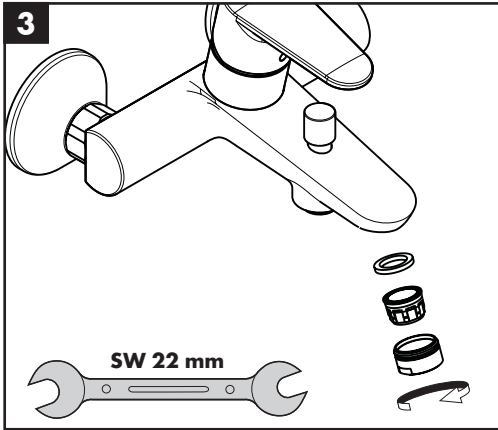
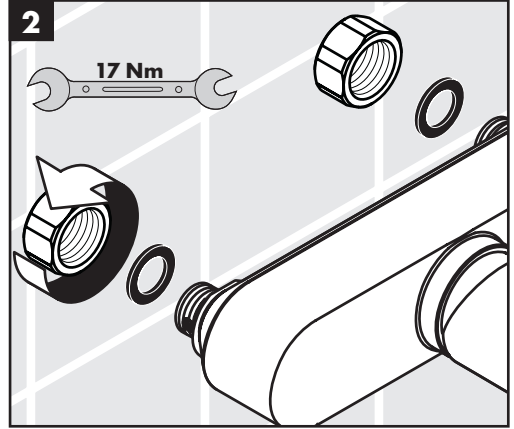
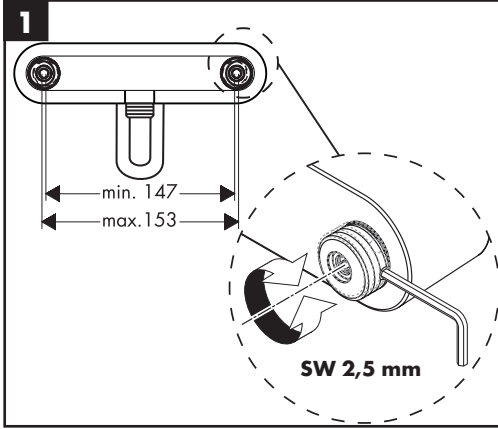

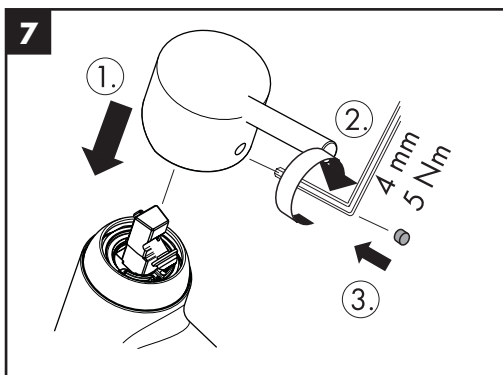
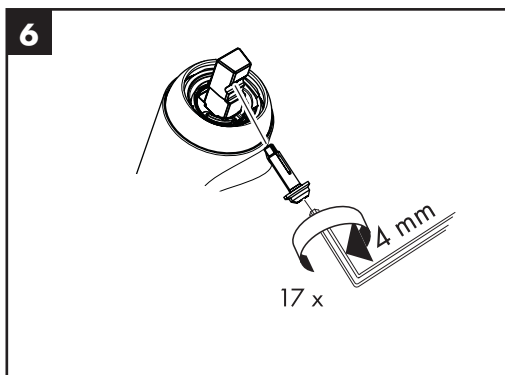
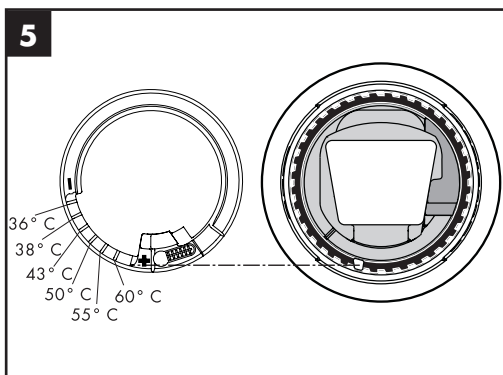
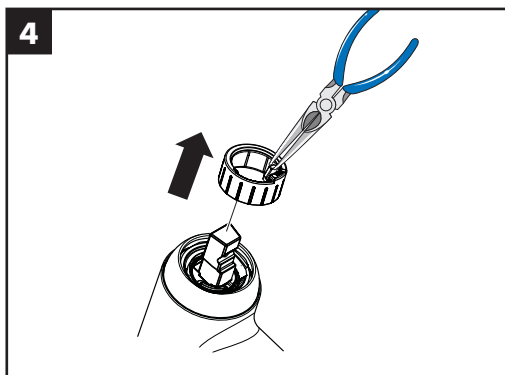
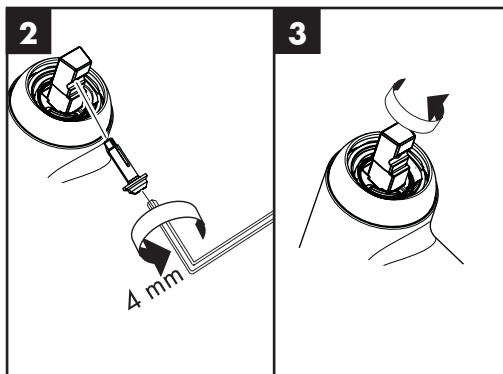
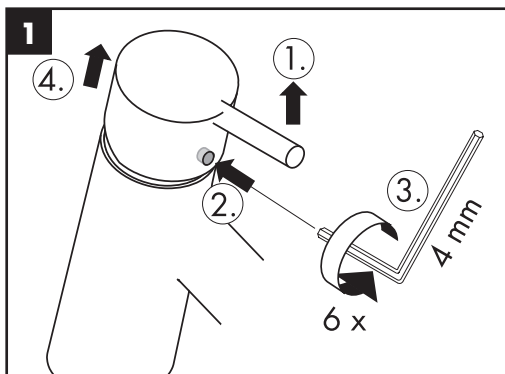



14470000 / 14470090

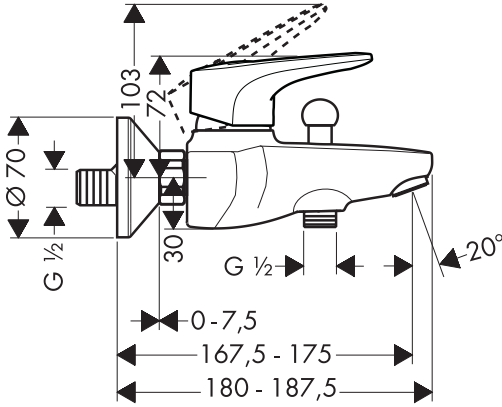

14670000 / 14670090

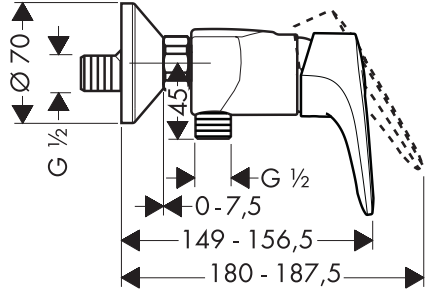

14470000 / 14470090

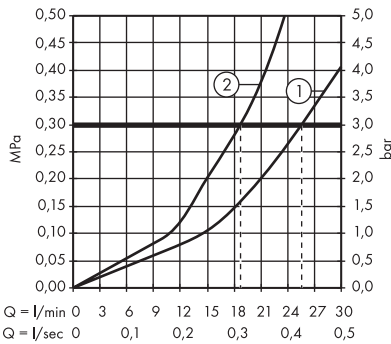

14670000 / 14670090

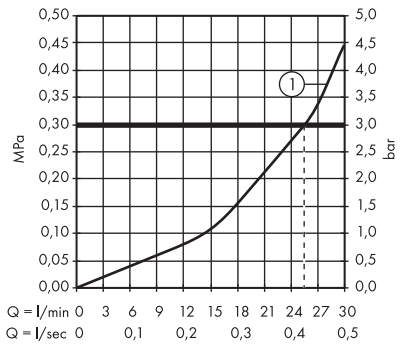



14474000

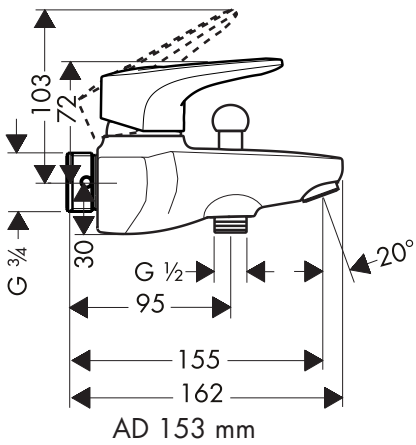

14674000

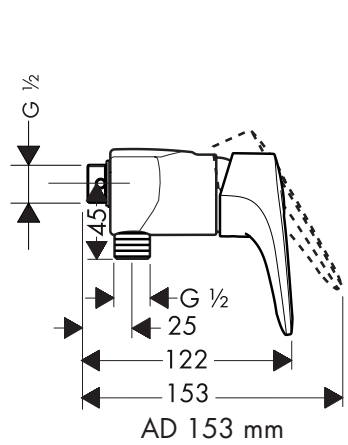

14474000

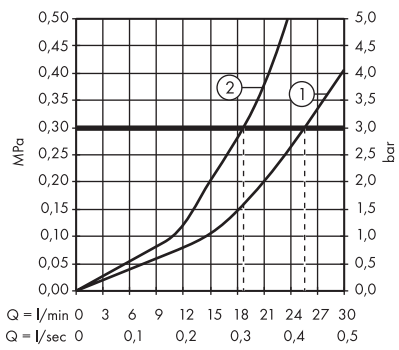

14674000

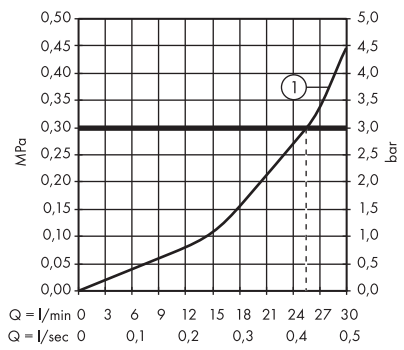



14470000 / 14470090

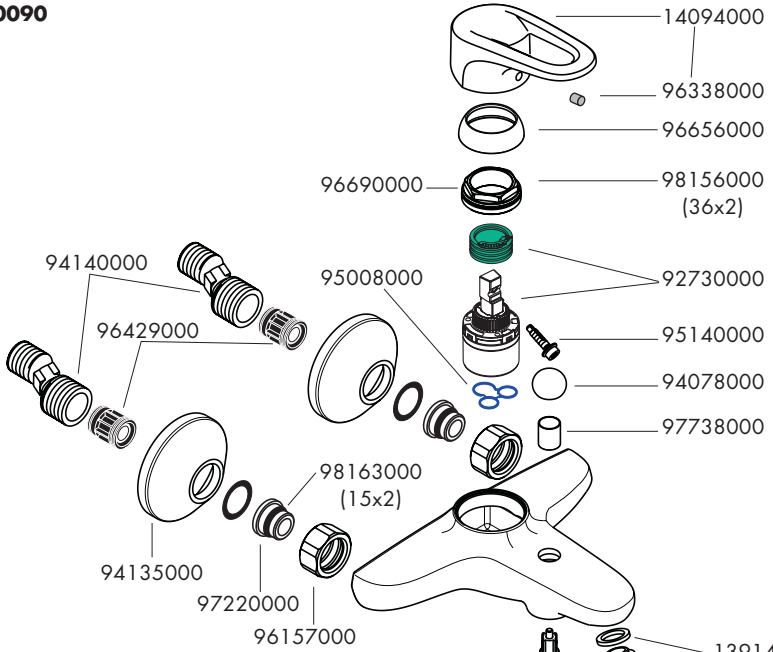

14670000 / 14670090

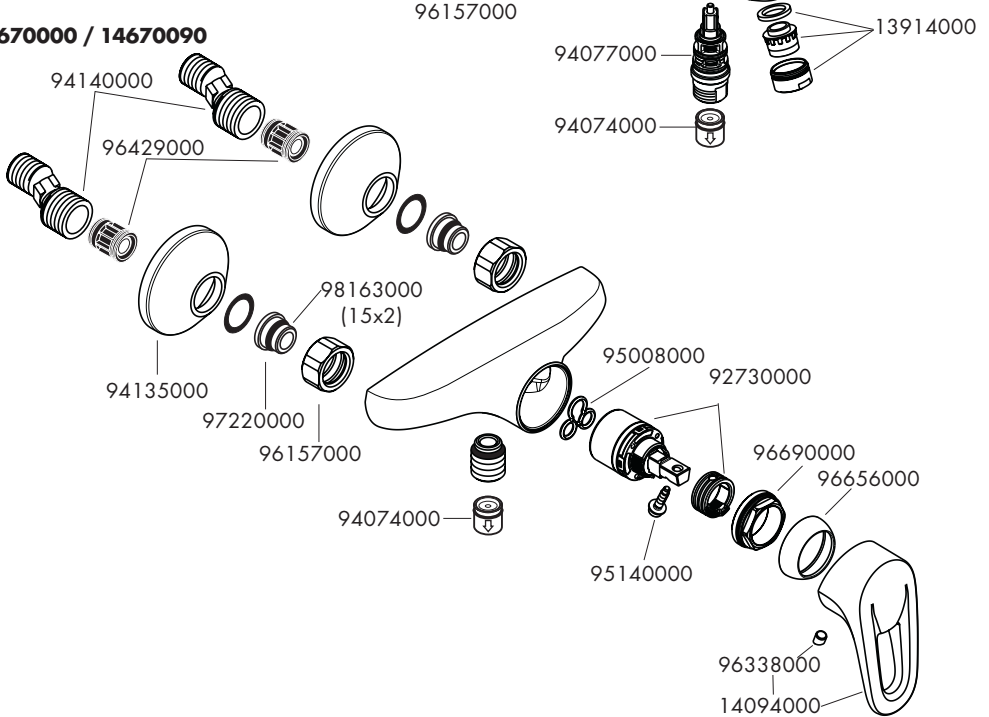

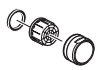

14474000

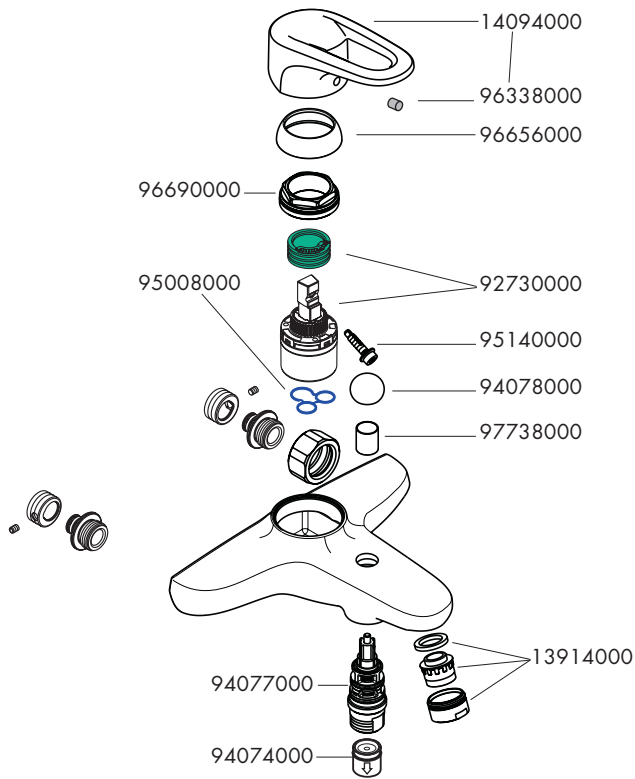

14674000

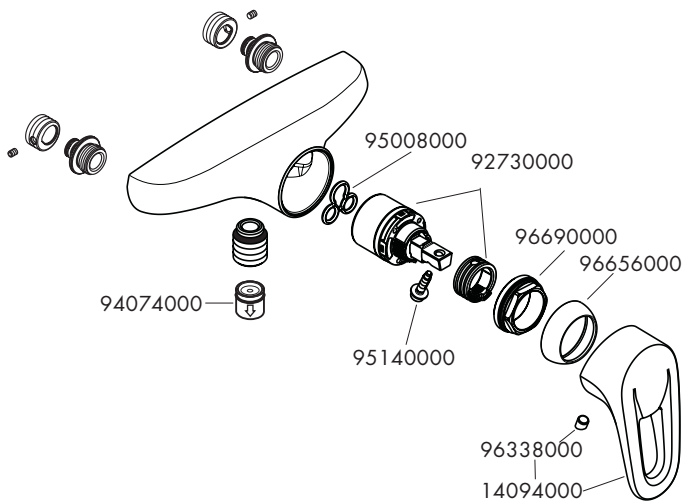

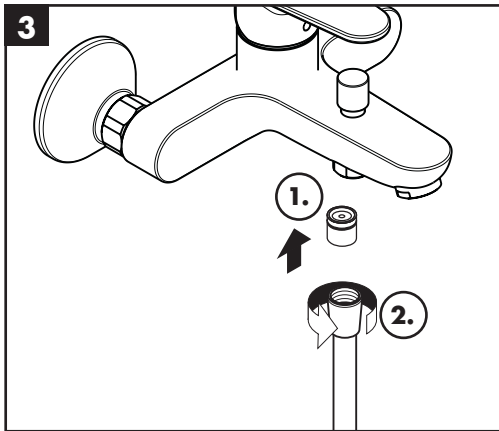
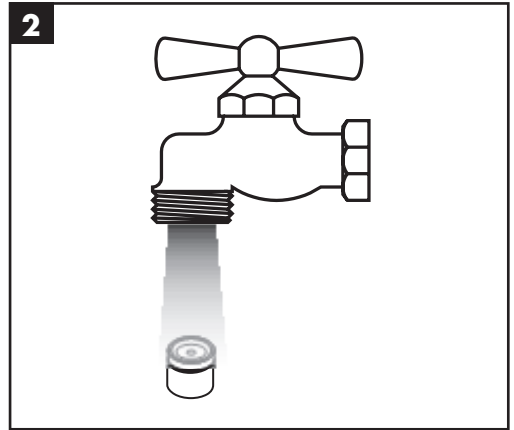
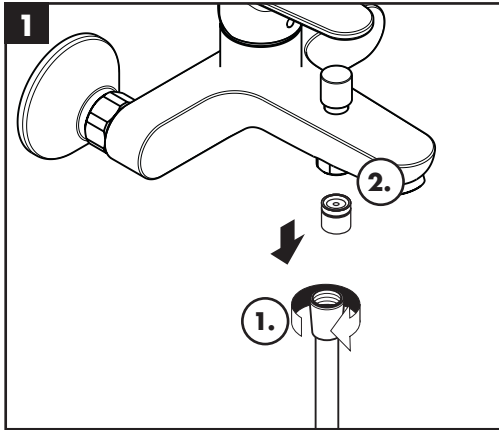

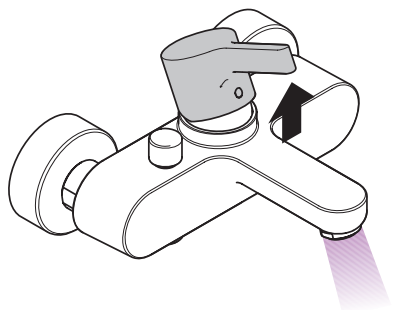

öffnen / ouvert / open / aperto / abierto / open / åbne /
 abrir / otworzyć / otevřít / otvorit / 开 / открыть / nyitás /
 avaaminen / öppna / atidaryti / Отваранье / açmak /
 deschide / ανοικτό / odpreti / avage / atvērt / otvoriti /
 åpne / отварање / hare / فتح

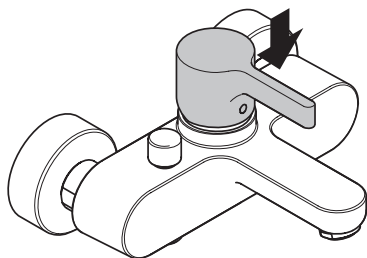

schließen / fermé / close / chiudere / cerrar / sluiten /
 lukke / fechar / zamknąć / zavřít / uzavrieť / 关 /
 закрыть / bezárás / sulkeminen / stänga / uždaryti /
 Zatvaranje / kapatmak / închide / κλειστό / zapreti /
 sulgege / aizvērt / zatvori / lukke / затварање / тбыл्लе /
 إغلاق

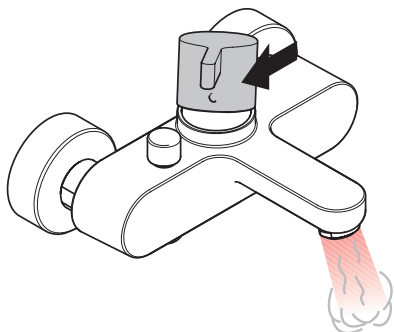

warm / chaud / hot / caldo / caliente / warm / varmt /
 quente / ciepła / teplá / teplá / 热 / горячая / meleg /
 lämmin / varmt / karštas / Vruća voda / sıcak / cald /
 ζεστό / toplo / kuum / karsts / topla / varm / тепло /
 i ngrøhtë / ساخن

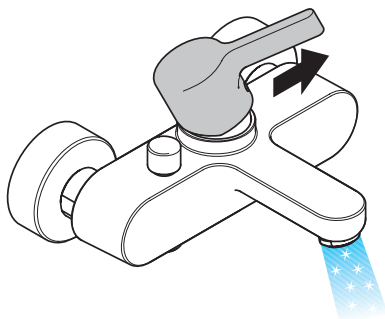

kalt / froid / cold / freddo / frío / koud / koldt / fria /
 zimna / studená / studená / 冷 / холодная / hideg /
 kylmä / kallt / šaltas / Hladno / soğuk / rece / крúо /
 mrzlo / külm / auksts / hladno / kaldt / студено / i ftohtë /
 بارد

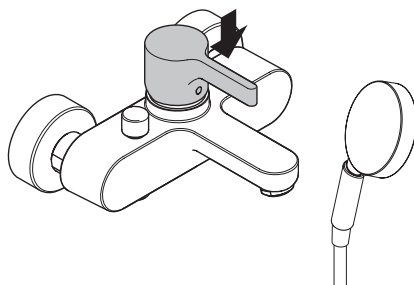
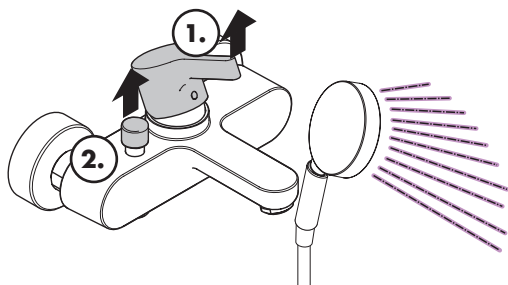



	P-IX	DVGW	SVGW	ACS	WRAS	ETA	KIWA
14470000 / 14470090	PA-IX 9873/IBB	BQ0557		X	X	1.42/18421	X
14474000							
14670000 / 14670090	PA-IX 9874/IA	BQ0557		X	X	1.42/19422	X
14674000							

