

<b>DE</b>	Gebrauchsanleitung / Montageanleitung	<b>2</b>
<b>FR</b>	Mode d'emploi / Instructions de montage	<b>4</b>
<b>EN</b>	Instructions for use / assembly instructions	<b>6</b>
<b>IT</b>	Istruzioni per l'uso / Istruzioni per Installazione	<b>8</b>
<b>ES</b>	Modo de empleo / Instrucciones de montaje	<b>10</b>
<b>NL</b>	Gebruiksaanwijzing / Handleiding	<b>12</b>
<b>DK</b>	Brugsanvisning / Monteringsvejledning	<b>14</b>
<b>RU</b>	Руководство пользователя / Инструкция по монтажу	<b>16</b>

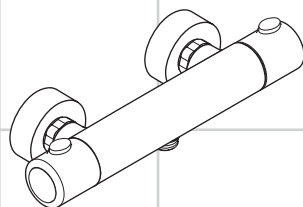

**Mediano**  
14261000

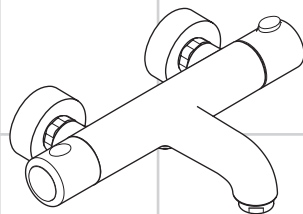

**Mediano**  
14241000



## Sicherheitshinweise

- ⚠ Bei der Montage müssen zur Vermeidung von Quetsch- und Schnittverletzungen Handschuhe getragen werden.
- ⚠ Das Produkt darf nur zu Bade-, Hygiene- und Körperreinigungszwecken eingesetzt werden.
- ⚠ Kinder, sowie Erwachsene mit körperlichen, geistigen und / oder sensorischen Einschränkungen dürfen das Produkt nicht unbeaufsichtigt benutzen. Personen, die unter Alkohol- oder Drogeneinfluss stehen, dürfen das Produkt nicht benutzen.
- ⚠ Große Druckunterschiede zwischen den Kalt- und Warmwasseranschlüssen müssen ausgeglichen werden.

## Montagehinweise

- Vor der Montage muss das Produkt auf Transportschäden untersucht werden. Nach dem Einbau werden keine Transport- oder Oberflächenschäden anerkannt.
- Die Leitungen und die Armatur müssen nach den gültigen Normen montiert, gespült und geprüft werden.
- Die in den Ländern jeweils gültigen Installationsrichtlinien sind einzuhalten.
- Das Produkt ist nicht für die Verwendung in Verbindung mit einem Dampfbad vorgesehen!

## Thermostat in Verbindung mit Durchlauferhitzern

- Wird eine Handbrause angeschlossen, so muss aus dieser eine eventuell vorhandene Drossel ausgebaut werden.
- Bei Problemen mit dem Durchlauferhitzer oder großen Druckunterschieden muss eine optional erhältliche Drossel (Artikelnummer 97510000) in den Kaltwasserzulauf eingesetzt werden.
- Thermostat Dusche: In Verbindung mit Durchlauferhitzern muss die ECOSTOP-Anschlagscheibe (#95042000) entfernt werden.

## Technische Daten

Betriebsdruck:	max. 1 MPa
Empfohlener Betriebsdruck:	0,1 - 0,5 MPa
Prüfdruck:	1,6 MPa
(1 MPa = 10 bar = 147 PSI)	
Heißwassertemperatur:	max. 80 °C
Empfohlene Heißwassertemperatur:	65 °C
Thermische Desinfektion:	max. 70 °C / 4 min
Anschlussmaße:	150 ± 12 mm
Anschlüsse G 1/2:	kalt rechts - warm links
Eigensicher gegen Rückfließen	

Das Produkt ist ausschließlich für Trinkwasser konzipiert!

## Symbolerklärung



Kein essigsäurehaltiges Silikon verwenden!

**max. ≈ 42 °C**

**Safety Function** (siehe Seite 21)

Dank der Safety Function lässt sich die gewünschte Höchsttemperatur von z. B. max. 42 °C voreinstellen.



**Einjustieren** (siehe Seite 20)

Nach erfolgter Montage muss die Auslauf-temperatur des Thermostaten überprüft werden. Eine Korrektur ist erforderlich wenn die an der Entnahmestelle gemessene Temperatur von der am Thermostaten eingestellten Temperatur abweicht.

**ECO ≈ 10 l**

**ECOSTOP** (siehe Seite 22)



**Wartung** (siehe Seite 23)

- Um die Leichtgängigkeit der Regeleinheit zu gewährleisten, sollte der Thermostat von Zeit zu Zeit auf ganz warm und ganz kalt gestellt werden.
- Der Thermostat ist mit Rückflussverhindern ausgestattet. Rückflussverhinderer müssen gemäß DIN EN 1717 regelmäßig in Übereinstimmung mit nationalen oder regionalen Bestimmungen (DIN 1988 einmal jährlich) auf ihre Funktion geprüft werden.



**Bedienung** (siehe Seite 26)



**Maße** (siehe Seite 24)



**Durchflussdiagramm** (siehe Seite 24)



**Serviceteile** (siehe Seite 25)



**Reinigung**

siehe beiliegende Broschüre



**Prüfzeichen** (siehe Seite 28)

## Störung

## Ursache

## Abhilfe

Wenig Wasser	<ul style="list-style-type: none"> <li>- Versorgungsdruck nicht ausreichend</li> <li>- Schmutzfangsiebe verschmutzt (#96922000)</li> <li>- Siebdichtung der Brause verschmutzt</li> </ul>	<ul style="list-style-type: none"> <li>- Leitungsdruck prüfen</li> <li>- Schmutzfangsiebe vor dem Thermostat und auf der Regeleinheit reinigen (#96922000)</li> <li>- Siebdichtung zwischen Brause und Schlauch reinigen</li> </ul>
Kreuzfluss, warmes Wasser wird bei geschlossener Armatur in die Kaltwasserleitung gedrückt oder umgekehrt	<ul style="list-style-type: none"> <li>- Rückflussverhinderer verschmutzt / defekt</li> </ul>	<ul style="list-style-type: none"> <li>- Rückflussverhinderer reinigen ggf. austauschen</li> </ul>
Auslauftemperatur stimmt nicht mit der eingestellten Temperatur überein	<ul style="list-style-type: none"> <li>- Thermostat wurde nicht justiert</li> <li>- Zu niedrige Warmwassertemperatur</li> </ul>	<ul style="list-style-type: none"> <li>- Thermostat justieren</li> <li>- Warmwassertemperatur erhöhen auf 42 °C bis 65 °C</li> </ul>
Temperaturregelung nicht möglich	<ul style="list-style-type: none"> <li>- Regeleinheit verkalkt</li> </ul>	<ul style="list-style-type: none"> <li>- Regeleinheit austauschen</li> </ul>
Brause oder Auslauf tropft	<ul style="list-style-type: none"> <li>- Schmutz oder Ablagerungen auf dem Dichtsitz, Absperrober teil beschädigt</li> </ul>	<ul style="list-style-type: none"> <li>- Absperrober teil reinigen bzw. austauschen</li> </ul>
Durchlauferhitzer schaltet bei Thermostatbetrieb nicht ein	<ul style="list-style-type: none"> <li>- Ecostop Anschlagscheibe nicht ausgebaut (#95042000)</li> <li>- Drossel in der Handbrause nicht ausgebaut</li> <li>- Schmutzfangsiebe verschmutzt</li> <li>- Rückflussverhinderer sitzt fest</li> </ul>	<ul style="list-style-type: none"> <li>- Ecostop Anschlagscheibe (#95042000) ausbauen</li> <li>- Drossel aus der Handbrause entfernen</li> <li>- Schmutzfangsieb reinigen / austauschen</li> <li>- Rückflussverhinderer austauschen</li> </ul>



**Montage siehe Seite 18**



## Consignes de sécurité

- △ Lors du montage, porter des gants de protection pour éviter toute blessure par écrasement ou coupure.
- △ Le système de douche ne doit servir qu'à se laver et à assurer l'hygiène corporelle.
- △ Il est interdit aux enfants ainsi qu'aux adultes ayant des insuffisances physiques, psychiques et/ou motoriques d'utiliser la douche sans surveillance. De même, il est interdit à des personnes sous influence d'alcool ou de drogues d'utiliser la douche.
- △ Il est conseillé d'équilibrer les pressions de l'eau chaude et froide.

## Instructions pour le montage

- Avant son montage, s'assurer que le produit n'a subi aucun dommage pendant le transport. Après le montage, tout dommage de transport ou de surface ne pourra pas être reconnu.
- Les conduites et la robinetterie doivent être montés, rincés et contrôlés selon les normes en vigueur.
- Les directives d'installation en vigueur dans le pays concerné doivent être respectées.
- Le produit n'est pas prévu pour une utilisation en liaison avec un bain à vapeur.

## Mitigeur thermostatique en fonctionnement avec de chauffe-eau-instantané

- Si besoin, retirer le limiteur de débit sur la douchette.
- On doit installer dans la tuyauterie eau froide un limiteur de débit (réf. 97510000) lors de problèmes rencontrés avec un chauffe-eau instantané ou bien lorsqu'il y a une trop grosse différence de pression.
- Mitigeur thermostatique Douche: En fonctionnement avec de chauffe-eau-instantané enlever la bague de butée ECOSTOP (#95042000).

## Informations techniques

Pression de service autorisée:	max. 1 MPa
Pression de service conseillée:	0,1 - 0,5 MPa
Pression maximum de contrôle:	1,6 MPa
(1 MPa = 10 bar = 147 PSI)	
Température d'eau chaude:	max. 80°C
Température recommandée:	65°C
Désinfection thermique:	max. 70°C / 4 min
Dimension d'arrivée:	150 ± 12 mm
Raccordement G 1/2:	froide à droite - chaude à gauche

Avec dispositif anti-retour

Le produit est exclusivement conçu pour de l'eau potable!

## Description du symbole



Ne pas utiliser de silicone contenant de l'acide acétique!

**max. Safety Function** (voir pages 21)  
**≈ 42°C**

Grâce à la fonction Safety, il est possible de pré régler la température maximale par exemple max. 42°C souhaitée.



**Réglage** (voir pages 20)

Le montage terminé, contrôler la température de l'eau puisée au mitigeur thermostatique. Un étalonnage est nécessaire si la température de l'eau mitigée mesurée au point de puisage diffère sensiblement de celle affichée sur le thermostat.

**ECO**  
**≈ 10 l**



**ECOSTOP** (voir pages 22)

**Entretien** (voir pages 23)

- Pour assurer le mouvement facile de l'élément thermostatique, le thermostat devrait être placé de temps en temps en position très chaude et très froide.
- Le mitigeur thermostatique est équipé de clapets anti-retour. Les clapets anti-retour doivent être examinés régulièrement conformément à la norme EN 1717 ou conformément aux dispositions nationales ou régionales quant à leur fonction (au moins une fois par an).



**Instructions de service** (voir pages 26)



**Dimensions** (voir pages 24)



**Diagramme du débit** (voir pages 24)



**Pièces détachées** (voir pages 25)



**Nettoyage**

voir la brochure ci-jointe



**Classification acoustique et débit** (voir pages 28)

## Dysfonctionnement

## Origine

## Solution

Pas assez d'eau	- Pression d'alimentation insuffisante	- Contrôler la pression
	- Filtres encrassés (#96922000)	- Nettoyer les filtres devant le mitigeur thermostatique et sur la cartouche (#96922000)
Circulation opposée, l'eau chaude est comprimée dans l'arrivée d'eau froide et vice versa avec robinet fermé	- Joint-filtre de douchette encrassé	- Nettoyer le joint-filtre entre la douchette et le flexible
	- Clapet anti-retour encrassé ou défectueux	- Nettoyer le clapet anti-retour ou le changer éventuellement
La température à la sortie ne correspond pas à la température de réglage	- Le thermostat n'a pas été réglé	- Régler le thermostat
	- Température d'eau chaude trop basse, pas d'eau froide	- Augmenter la température d'eau chaude entre 42°C et 65°C
Le réglage de la température n'est pas possible	- Cartouche thermostatique entartrée	- Changer la cartouche thermostatique
La douchette ou le bec verseur goutte	- De la saleté ou de l'incrustation sur le siège, mécanisme d'arrêt défectueux	- Nettoyez le mécanisme d'arrêt ou le changez éventuellement
Le chauffe-eau instantané ne s'allume pas lors de l'utilisation du thermostat	- Bague de butée non démontée (#95042000)	- Ecostop Démontez la bague de butée (#95042000)
	- Réducteur de débit non démonté	- Démontez le réducteur de débit de la douchette
	- Filtres encrassés	- Nettoyez / changez le filtre
	- Clapet anti-retour bloqué	- Changez le clapet antiretour



**Montage voir pages 18**



## Safety Notes

- △ Gloves should be worn during installation to prevent crushing and cutting injuries.
- △ The shower system may only be used for bathing, hygienic and body cleaning purposes.
- △ Children as well as adults with physical, mental and/or sensoric impairments must not use this product without proper supervision. Persons under the influence of alcohol or drugs are prohibited from using this product.
- △ The hot and cold supplies must be of equal pressures.

## Installation Instructions

- Prior to installation, inspect the product for transport damages. After it has been installed, no transport or surface damage will be honoured.
- The pipes and the fixture must be installed, flushed and tested as per the applicable standards.
- The plumbing codes applicable in the respective countries must be observed.
- The product is not designed to be used with steam baths!

## Thermostatic mixer in conjunction with combination boilers

- If fitting a hand shower remove the water limiter from the shower.
- If the continuous water heater causes any problems, or you have different water pressures you must install a water limiter to the cold supply, (ordered separately, article number 97510000).
- Thermostatic mixer Shower: When using the Ecostat with combination boilers, the Ecostop safety set (#95042000) has to be removed.

## Technical Data

Operating pressure:	max. 1 MPa
Recommended operating pressure:	0,1 - 0,5 MPa
Test pressure:	1,6 MPa
(1 MPa = 10 bar = 147 PSI)	
Hot water temperature:	max. 80°C
Recommended hot water temp.:	65°C
Thermal disinfection:	max. 70°C / 4 min
Centre distance:	150 ± 12 mm
Connections G 1/2:	cold right - hot left

Safety against backflow

The product is exclusively designed for drinking water!

## Symbol description



Do not use silicone containing acetic acid!

## max. Safety Function (see page 21)

≈ 42°C

The desired maximum temperature for example max. 42°C can be pre-set thanks to the safety function.



## Adjustment (see page 20)

After the installation, the output temperature of the thermostat must be checked. A correction is necessary if the temperature measured at the output differs from the temperature set on the thermostat.

**ECO**  
≈ 10 l

## ECOSTOP (see page 22)



## Maintenance (see page 23)

- To guarantee the smooth running of the thermostat, it is necessary from time to time to turn the thermostat from total hot to total cold.
- The mixer is equipped with check valves. The check valves must be checked regularly according to DIN EN 1717 in accordance with national or regional regulations (at least once a year).



**Operation** (see page 26)



**Dimensions** (see page 24)



**Flow diagram** (see page 24)



**Spare parts** (see page 25)



**Cleaning**

see enclosed brochure



**Test certificate** (see page 28)

<b>Fault</b>	<b>Cause</b>	<b>Remedy</b>
Insufficient water	- Supply pressure inadequate	- Check water pressure (If a pump has been installed check to see if the pump is working).
	- Filters are dirty (#96922000)	- Clean filter in front of the mixer and on the MTC-thermo cartridge (#96922000)
	- Shower filter seal dirty	- Clean filter seal between shower and hose
Crossflow, hot water being forced into cold water pipe, or vice versa, when mixer is closed	- Backflow preventers dirty or leaking	- Clean backflow preventers, exchange if necessary
Spout temperature does not correspond with temperature set	- Thermostat has not been adjusted	- Adjust thermostat
	- Hot water temperature too low	- Increase hot water temperature to 42 °C to 65 °C
Temperature regulation not possible	- thermo cartridge calcified	- Exchange thermo cartridge
Shower or spout dripping	- Dirt or sedimentation on valve seat, shut-off unit damaged	- Clean or exchange shut-off unit
Instantaneous heater didn't work with thermostat	- Ecostop safety set removed. (#95042000)	- Ecostop Remove Ecostop safety set (#95042000)
	- Flow limiter in handshower isn't removed	- Remove flow limiter
	- Filters are dirty	- Clean the filter / exchange filter
	- check valve hasn't moved back	- Exchange check valves



**Assembly see page 18**



## **Indicazioni sulla sicurezza**

- ⚠ Durante il montaggio, per evitare ferite da schiacciamento e da taglio bisogna indossare guanti protettivi.
- ⚠ Il sistema doccia deve essere utilizzato esclusivamente per l'igiene del corpo.
- ⚠ I bambini e gli adulti affetti da menomazioni fisiche, psichiche e/o sensoriali devono utilizzare il sistema doccia solo sotto sorveglianza. Il prodotto non deve essere utilizzato da persone sotto l'effetto di droghe o alcolici.
- ⚠ **Attenzione!** Compensare le differenze di pressione tra i collegamenti dell'acqua fredda e dell'acqua calda.

## **Istruzioni per il montaggio**

- Prima del montaggio è necessario controllare che non ci siano stati danni durante il trasporto. Una volta eseguito il montaggio, non verranno riconosciuti eventuali danni di trasporto o delle superfici.
- Montare, lavare e controllare tubature e rubinetteria rispettando le norme correnti.
- Vanno rispettate le direttive di installazione nazionali vigenti nel rispettivo paese.
- Il prodotto non è predisposto per l'impiego in combinazione con un bagno a vapore.

## **Termostatico in combinazione con scaldabagni istantanei**

- Inoltre, nella docetta che verrà installata, sarà anche necessario inserire un riduttore di portata.
- In caso di problemi con lo scaldacqua istantaneo oppure di grandi differenze di pressione bisogna inserire un limitatore di portata disponibile come optional (codice articolo 97510000) nel tubo d'entrata dell'acqua fredda.
- Termostatico Doccia: In combinazione con scaldabagni istantanei deve essere disattivato il tasto di risparmio d'acqua ECOSTOP (#95042000).

## **Dati tecnici**

Pressione d'uso:	max. 1 MPa
Pressione d'uso consigliata:	0,1 - 0,5 MPa
Pressione di prova:	1,6 MPa
(1 MPa = 10 bar = 147 PSI)	
Temperatura dell'acqua calda:	max. 80 °C
Temp. dell'acqua calda consigliata:	65 °C
Disinfezione termica:	max. 70 °C / 4 min
Distanza di raccordo:	150 ± 12 mm
Raccordi G 1/2:	fredda a destra - calda a sinistra

Sicurezza antiriflusso

Il prodotto è concepito esclusivamente per acqua potabile!

## **Descrizione simbolo**



Non utilizzare silicone contenente acido acetico!

## **max. Safety Function** (vedi pagg. 21)

≈ 42 °C

Grazie alla funzione antiscottature Safety la temperatura massima per esempio max. 42 °C desiderata è facilmente regolabile.



## **Taratura** (vedi pagg. 20)

Effettuata l'installazione del miscelatore termostatico bisogna controllare la temperatura di uscita. La taratura è necessaria quando la temperatura dell'acqua misurata sul punto di prelievo non corrisponde a quella fissata sul termostato.

**ECO**  
≈ 10 l

## **ECOSTOP** (vedi pagg. 22)



## **Manutenzione** (vedi pagg. 23)

- Per garantire la scorrevolezza dell'elemento di regolazione, di tanto in tanto si dovrebbe regolare il termostatico passando da tutto caldo a tutto freddo.
- Il miscelatore termostatico è dotato di una valvola antiriflusso. La valvola di non ritorno deve essere controllata regolarmente come da DIN EN 1717, secondo le normative nazionali e regionali (almeno una volta all'anno).





**Procedura** (vedi pagg. 26)



**Ingombri** (vedi pagg. 24)



**Diagramma flusso** (vedi pagg. 24)



**Parti di ricambio** (vedi pagg. 25)



**Pulitura**

vedi il prospetto accluso



**Segno di verifica** (vedi pagg. 28)

<b>Problema</b>	<b>Possibile causa</b>	<b>Rimedio</b>
Scarsità d'acqua	- Pressione di erogazione insufficiente - Filtri sporchi (#96922000) - Guarnizione del filtro della doccia sporca	- Provare la pressione di erogazione - Pulire/sostituire i filtri (#96922000) - Pulire la guarnizione del filtro tra doccia e flessibile
Flusso incrociato; l'acqua calda viene spinta nella tubatura acqua fredda a rubinetteria chiusa o viceversa	- Antiriflusso sporco o non ermetico	- Pulire o sostituire l'antiriflusso
La temperatura di erogazione diversa da quella impostata	- Il termostatico non è stato regolato - Temperatura dell'acqua calda	- Regolare il termostatico - Aumentare la temperatura acqua calda tra 42 °C e 65 °C
Impossibile la regolazione temperatura	- Unità di regolazione piena di calcare	- Sostituire l'unità di regolazione
Doccia / scarico gocciola	- Sporco o depositi nella sede della guarnizione, vitone di arresto danneggiato	- Pulire o sostituire il vitone di arresto
La caldaia istantanea non lavora con il termostato in funzione	- L'anello Ecostop non è stato smontato (#95042000) - Il limitatore di portata non è stato smontato dalla doccia - Filtri sporchi - Valvola antiriflusso non funziona correttamente	- Ecostop Smontare l'anello Ecostop (#95042000) - Smontare il limitatore di portata dalla doccia - Pulire / sostituire il filtro - Sostituire la valvola antiriflusso





## Indicaciones de seguridad

- ⚠ Durante el montaje deben utilizarse guantes para evitar heridas por aplastamiento o corte.
- ⚠ La grifería solo debe ser utilizada para fines de baño, higiene y limpieza corporal.
- ⚠ Niños, así como adultos con limitaciones corporales, mentales y/o sensoriales no deben utilizar el sistema de duchas sin vigilancia. Personas que se encuentran bajo el efecto de alcohol o drogas, no deben utilizar el sistema de duchas.
- ⚠ Grandes diferencias de presión en servicio entre agua fría y agua caliente deben equilibrarse.

## Indicaciones para el montaje

- Antes del montaje se debe examinarse el producto contra daños de transporte. Después de la instalación se reconoce ningún daño de transporte o de superficie.
- Los conductos y la grifería deben montarse, lavarse y comprobarse según las normas vigentes.
- Es obligatorio el cumplimiento de las directrices de instalación vigentes en el país respectivo.
- ¡El producto no ha sido diseñado para uso en conexión con un baño de vapor!

## Termostato en uso con calentadores instantáneos

- La teleducha debe funcionar sin reductor de caudal.
- Cuando aparezcan problemas con el calentador continuo o con diferencias de presión grandes debe instalarse un regulador de presión suplementario (Ref. 97510000) en la conexión de agua fría.
- Termostato Ducha: Usando calentadores instantáneos hay que quitar el anillo tope (#95042000).

## Datos técnicos

Presión en servicio:	max. 1 MPa
Presión recomendada en servicio:	0,1 - 0,5 MPa
Presión de prueba:	1,6 MPa
(1 MPa = 10 bar = 147 PSI)	
Temperatura del agua caliente:	max. 80 °C
Temp. recomendada del agua caliente:	65 °C
Desinfección térmica:	max. 70 °C / 4 min
Racores excéntricos:	150 ± 12 mm
Racores excéntricos G 1/2:	a la derecha frío - a la izquierda caliente

Seguro contra el retorno

El producto ha sido concebido exclusivamente para agua potable.

## Descripción de símbolos



No utilizar silicona que contiene ácido acético!

## max. Safety Function (ver página 21)

≈ 42 °C

Gracias al tope de temperatura se puede graduar la temperatura máxima por ejemplo max. 42 °C.



## Puesta a punto (ver página 20)

Después del montaje deberá comprobarse la temperatura del agua del termostato, en la salida del caño. Una corrección se efectuará siempre y cuando la temperatura del agua tomada a la salida del caño, no corresponda con la indicada en el volante del termostato.

ECO  
≈ 10 l

## ECOSTOP (ver página 22)



## Mantenimiento (ver página 23)

- Para garantizar el funcionamiento duradero del termostato, el mando del mismo debería girarse de vez en cuando del extremo frío al extremo caliente.
- El termostato está equipado con válvula, la cual evita el retorno del agua a la tubería. Las válvulas anti-retorno tienen que ser controladas regularmente según la norma DIN EN 1717, en acuerdo con las regulaciones nacionales o regionales (una vez al año, por lo menos).



**Manejo** (ver página 26)



**Dimensiones** (ver página 24)



**Diagrama de circulación** (ver página 24)



**Repuestos** (ver página 25)



**Limpiar**

ver el folleto adjunto



**Marca de verificación** (ver página 28)

<b>Problema</b>	<b>Causa</b>	<b>Solución</b>
Sale poca agua	- presión insuficiente	- comprobar presión
	- Filtros sucios (#96922000)	- Limpiar filtros en las uniones a las tomas de agua caliente y fría y en el cartucho termostático (#96922000)
Flujo de agua cruzada agua caliente entra en la tubería del agua fría o al revés	- Filtro de la teleducha sucio	- Limpiar / Cambiar filtro entre flexo y teleducha
	- válvula antirretorno sucia o pierde	- limpiar / cambiar válvula
Temperatura del agua no corresponde a lo marcado	- termostato no ha sido ajustado	- ajustar termostato
	- Temperatura del agua caliente demasiado baja	- aumentar temperatura del agua caliente a 42° - 65° C.
No es posible regular la temperatura	- Termoelemento calcificado o desgastado	- cambiar termoelemento
Pierde permanentemente agua por el caño	- Suciedad / Sedimentaciones en el asiento de la llave, o llave dañada	- Limpiar/Cambiar llave de paso
Calentador instantáneo no se enciende cuando el termostato mezcla agua caliente con agua fría	- Anillo de tope Ecostop aún montado (#95042000)	- Ecostop quitar tope de caudal (#95042000)
	- no se ha quitado limitador de caudal de la teleducha	- quitar limitador de caudal
	- Filtros sucios	- limpiar/cambiar el filtro
	- válvula anti-retorno cerrada	- cambiar válvula anti-retorno



**Montaje ver página 18**



## Veiligheidsinstructies

- △ Bij de montage moeten ter voorkoming van knel- en snijwonden handschoenen worden gedragen.
- △ Het douchesysteem mag alleen voor het wassen, hygiënische doeleinden en voor de lichaamreiniging worden gebruikt.
- △ Kinderen en volwassenen met lichamelijke, geestelijke en/of sensorische beperkingen mogen het douchesysteem niet zonder toezicht gebruiken. Personen onder invloed van alcohol of drugs mogen het douchesysteem niet gebruiken.
- △ Grote drukverschillen tussen de koud- en warmwatertoevoer dienen vermeden te worden.

## Montage-instructies

- Vóór de montage moet het product gecontroleerd worden op transportschade. Na de inbouw wordt geen transport- of oppervlakteschade meer aanvaard.
- De leidingen en armaturen moeten gemonteerd, gespoeld en gecontroleerd worden volgens de geldige normen.
- De in de overeenkomstige landen geldende installatierichtlijnen moeten nageleefd worden.
- Het product is niet voorzien voor gebruik in combinatie met een stoombad!

## Thermostaat en combinatie met een geiser

- Indien er een handdouché aangesloten wordt, dan dient de eventueel aanwezige doorstroombegrenzer eveneens verwijderd te worden.
- Indien de thermostaatkraan "pulseert" wordt dit veroorzaakt door de warmwater voorziening of door te grote drukverschillen tussen de warm- en koudwater toevoer. In dit geval dient er in de koudwatertoevoerleiding, de als optie verkrijgbare, "doorstroombegrenzer of remplaatje" nr. 97510000 ingebouwd te worden.
- Thermostaat Douche: In combinatie met een geiser moet aanslagring (#95042000) van de ECOSTAT verwijderd worden.

## Technische gegevens

Werkdruk: max.	max. 1 MPa
Aanbevolen werkdruk:	0,1 - 0,5 MPa
Getest bij:	1,6 MPa
(1 MPa = 10 bar = 147 PSI)	
Temperatuur warm water:	max. 80°C
Aanbevolen warm water temp.:	65°C
Thermische desinfectie:	max. 70°C / 4 min
Aansluitmaten:	150 ± 12 mm
Aansluitingen G 1/2:	koud rechts - warm links
Beveiligd tegen terugstromen	

Het product is uitsluitend ontworpen voor drinkwater!

## Symboolbeschrijving



Gebruik geen zuurhoudende silicone!

**max.**  
≈ 42°C

**Safety Function** (zie blz. 21)

Dankzij de Safety Function kan de gewenste maximale temperatuur van bijv. max. 42°C van te voren worden ingesteld.



**Correctie** (zie blz. 20)

Na montage dient de uitstroomtemperatuur van de thermostaat gecontroleerd te worden. Een correctie is noodzakelijk als de aan het tappunt gemeten temperatuur afwijkt van de op de thermostaat ingestelde temperatuur.

**ECO**  
≈ 10 l

**ECOSTOP** (zie blz. 22)



**Onderhoud** (zie blz. 23)

- Om het soepel lopen van de regelbaarheid te garanderen moet de thermostaat van tijd tot tijd op heel koud en heel warm worden ingesteld.
- De thermostaat is voorzien van terugslagkleppen. Keerklappen moeten volgens DIN EN 1717 regelmatig en volgens plaatselijk geldende eisen op het functioneren gecontroleerd worden. (Tenminste een keer per jaar).



**Bediening** (zie blz. 26)



**Maten** (zie blz. 24)



**Doorstroomdiagram** (zie blz. 24)



**Service onderdelen** (zie blz. 25)



**Reinigen**

zie bijgevoegde brochure



**Keurmerk** (zie blz. 28)

<b>Storing</b>	<b>Oorzaak</b>	<b>Oplossing</b>
Weinig water	- Druk te laag - Vuilzeef verstopt (#96922000)	- Druk controleren - Vuilvangzeefjes en zeefjes van regeleenheid reinigen (#96922000)
Kruisstroom, warm water stroomt in gesloten toestand in koud water leiding of omgekeerd	- Zeefdichting handdouche verstopt - Terugslagkleppen vervuild of defect	- Zeefdichting handdouche reinigen - Terugslagkleppen reinigen dan wel uitwisselen
Uitstroomtemperatuur komt niet met ingestelde temperatuur overeen	- Thermostaat niet ingesteld - Temperatuur van warm water te laag	- Thermostaat instellen - Warmwater toevoer verhogen min. 42°C naar 65°C
Temperatuur niet regelbaar	- regeleenheid verkalkt	- regeleenheid uitwisselen
Douche/uitloop lekt	- Vuil of verkalking op de zitting, bovendeeel beschadigd	- Bovendeeel reinigen of omstelling uitwisselen
Doorstroomtoestel schakelt tijdens gebruik van thermostaat niet in	- Ecostop aanslagring niet verwijderd (#95042000) - Begrenzer van handdouche niet verwijderd - Vuilzeef verstopt - Terugslagklep zit vast	- Ecostop Aanslagring verwijderen (#95042000t) - Begrenzer uit handdouche verwijderen - Vuilvangzeef reinigen / uitwisselen - Terugslagklep uitwisselen



**Montage zie blz. 18**



## Sikkerhedsanvisninger

- ⚠ Ved monteringen skal der bruges handsker for at undgå kvæstelser og snitsår.
- ⚠ Brusersystemet må kun bruges til bade-, hygiejne og rengøringsformål.
- ⚠ Børn som også voksne med fysiske, mentale og / eller sensoriske begrænsninger må ikke bruge brusersystemet uden opsyn. Personer som er under indflydelse af alkohol eller narkotika må ikke bruge brusersystemet.
- ⚠ Større trykforskelle mellem koldt og varmt vand bør udjævnes.

## Monteringsanvisninger

- Før monteringen skal produktet kontrolleres for transportskader. Efter monteringen godkendes transportskader eller skader på overfladen ikke længere.
- Ledningerne og armaturerne skal monteres, skylles og kontrolleres iht. de gældende standarder.
- Installationsbestemmelserne, der gælder i det enkelte land, skal overholdes.
- Dette produkt er ikke beregnet til anvendelse i forbindelse med et dampbad!

## Termostat i forbindelse med gennemstrømningsvandvarmer

- Hvis der tilsluttes en håndbruser, skal en drossel (hvis der findes en) fjernes.
- Ved problemer med gennemstrømningsvandvarmer eller for lavt vandtryk, skal der monteres en speciel vandbegrænser i koldt vandstilgangen (art.nr. 97510000).
- Termostat Bruser: I forbindelse med gennemstrømningsvandvarmere skal ECOSTOP-anlagsskiven (#95042000) fjernes.

## Tekniske data

Driftstryk:	max. 1 MPa
Anbefalet driftstryk:	0,1 - 0,5 MPa
Prøvetryk:	1,6 MPa
(1 MPa = 10 bar = 147 PSI)	
Varmtvandstemperatur:	max. 80 °C
Anbefalet varmtvandstemperatur:	65 °C
Termisk desinfektion:	max. 70 °C / 4 min
Tilslutningsmål:	150 ± 12 mm
Tilslutninger G 1/2:	Koldt højre - varmt venstre

Med indbygget kontraventil

Produktet er udelukkende beregnet til drikkevand!

## Symbolbeskrivelse



Der må ikke benyttes eddikesyreholdig silikone!

## max. Safety Function (se s. 21)

≈ 42 °C

Takket være Safety varmtvands-begrænsning kan maksimaltemperaturen forudindstilles eksempel max. 42° C.



## Justering (se s. 20)

Efter monteringen skal termostatsens udløbstemperatur kontrolleres. Såfremt den målte vandtemperatur afviger fra den på termostaten viste forindstilling er en korrigerende skalagreb nødvendig.

ECO  
≈ 10 l

## ECOSTOP (se s. 22)



## Service (se s. 23)

- For at sikre optimal funktion af termostaten, bør termostaten fra tid til anden motioneres (stilles skiftevis helt varm og helt kold).
- Termostaten er forsynet med kontraventil . Ifølge DIN EN 1717 skal gennemstrømningsbegrænsere i overensstemmelse med nationale regler afprøves regelmæssigt (mindst en gang om året).



**Brugsanvisning** (se s. 26)



**Målene** (se s. 24)



**Gennemstrømningsdiagram** (se s. 24)



**Reservevedele** (se s. 25)



**Rengøring**

se venligst den vedlagte brochure



**Godkendelse** (se s. 28)

Fejl	Årsag	Hjælp
For lidt vand	<ul style="list-style-type: none"> <li>- Forsyningsstrykket er ikke højt nok</li> <li>- Smudsfangsien er snavset (#96922000)</li> <li>- Sien mellem bruser og slange er snavset</li> </ul>	<ul style="list-style-type: none"> <li>- Afprøv forsyningsstrykket</li> <li>- Rengør smudsfangsi foran termosstaten og på termosstatelementet (#96922000)</li> <li>- Rengør sien mellem bruser og slange</li> </ul>
Kryds-flow, varmt vand i koldtvandsledningen og omvendt	<ul style="list-style-type: none"> <li>- Kontraventilen er snavset eller utæt.</li> </ul>	<ul style="list-style-type: none"> <li>- Rengør kontraventilen eller udskift den evt.</li> </ul>
Udløbstemperaturen stemmer ikke overens med den indstillede temperatur	<ul style="list-style-type: none"> <li>- Termosstaten er ikke justeret</li> <li>- For lav varmtvands-temperatur</li> </ul>	<ul style="list-style-type: none"> <li>- Juster termosstaten</li> <li>- Forhøj varmtvands-temperaturen fra 42°C til 65°C</li> </ul>
Temperaturregulering ikke mulig	<ul style="list-style-type: none"> <li>- katuschen er tilkalket</li> </ul>	<ul style="list-style-type: none"> <li>- Udskift katuschen</li> </ul>
Bruser/kartud drypper	<ul style="list-style-type: none"> <li>- Snavs eller kalk på pakningen, beskadiget afspærringsventil</li> </ul>	<ul style="list-style-type: none"> <li>- Rengør afspærrings-ventil eller udskift evt.</li> </ul>
Vandvarmeren går ikke i gang ved aktivering af termosstat	<ul style="list-style-type: none"> <li>- Ecoston-anlagsringen er ikke fjernet (#95042000)</li> <li>- Vandsparen i håndbruseren er ikke fjernet</li> <li>- Smudsfangsien er snavset</li> <li>- Kontraventilen hænger</li> </ul>	<ul style="list-style-type: none"> <li>- Ecoston Afmonter (#95042000) anlagsringen</li> <li>- Afmonter vandsparen i håndbruseren</li> <li>- Rengør / udskift smudsfangsi</li> <li>- Udskift kontraventil</li> </ul>





## Указания по технике безопасности

- △ Во время монтажа следует надеть перчатки во избежание прищемления и порезов.
- △ Изделие разрешается использовать только в гигиенических целях: для принятия ванны и личной гигиены.
- △ Дети, а также взрослые с физическими, умственными и/или сенсорными недостатками должны пользоваться изделием только под присмотром. Запрещается пользоваться изделием в состоянии алкогольного или наркотического опьянения.
- △ донного клапа. Перед установкой смесителя необходимо регулировочными кранами выровнять давление холодной и горячей воды при помощи вентилей регулирующих подачу воды в квартиру.

## Указания по монтажу

- Перед монтажом следует проверить изделие на предмет повреждений при перевозке. После монтажа претензии о возмещении ущерба за повреждения при перевозке или повреждения поверхностей не принимаются.
- Трубы и арматура должны быть установлены, промыты и проверены в соответствии с действующими нормами.
- Необходимо соблюдать требования по монтажу, действующие в соответствующих странах.
- Изделие не предназначено для использования в паровой бане!

## Термостат с проточными нагревателями

- При подключении ручного душа, из него необходимо удалить возможно установленный в нем дроссель.
- При неполадках проточного нагревателя или значительных перепадах давления в подвод холодной воды следует установить дроссель, приобретаемый дополнительно (арт. № 97510000).
- Термостат душ: При использовании с проточными нагревателями необходимо удалить упорную шайбу (#95042000) ECOSTOP.

## Технические данные

Рабочее давление: не более. 1 МПа  
 Рекомендуемое рабочее давление: 0,1 - 0,5 МПа  
 Давлении: 1,6 МПа  
 (1 МПа = 10 bar = 147 PSI)  
 Температура горячей воды: не более. 80°C  
 Рекомендуемая темп. гор. воды: 65°C  
 Термическая дезинфекция: не более. 70°C / 4 мин  
 Размеры подключения: 150 ± 12 mm  
 Подключение G 1/2: холодная справа - горячая слева  
 укомплектован клапаном обратного тока воды

Изделие предназначено исключительно для питьевой воды!

## Описание символов



Не применяйте силикон, содержащий усусную кислоту.

## max. Safety Function (см. стр. 21)

≈ 42°C

С помощью функции Safety Function может быть задана максимальная температура воды, например 42°C.



## Настройка (см. стр. 20)

После монтажа следует проверить температуру на выходе из термостата. Скорректируйте температуру воды, если она отличается от установленной на термостате.

ECO  
≈ 10 l

## ECOSTOP (см. стр. 22)



## Техническое обслуживание

(см. стр. 23)

- Для гарантии плавного изменения температуры и долгого срока службы необходимо периодически поворачивать ручку регулировки температуры из положение максимально горячая в положение максимально холодная вода.
- Термостат оснащен клапанами обратного течения. Защита обратного тока должна регулярно проверяться (минимум один раз в год) по стандарту DIN EN 1717 или в соответствии с национальными или региональными нормативами





**Эксплуатация** (см. стр. 26)



**Размеры** (см. стр. 24)



**Схема потока** (см. стр. 24)



**Комплект** (см. стр. 25)



**Очистка**

см прилагаемая брошюра



**Знак технического контроля**  
(см. стр. 28)

<b>Неисправность</b>	<b>Причина</b>	<b>Устранение неисправности</b>
недостаточный давление (если устан напор воды)	- Проблемы водоснабжения	- Проверить овлен насос проверить работу насоса
	- Грязеулавливающие сита загрязнены (#96922000)	- Очистите грязеулавливающие сита перед термостатом и на регуляторе (#96922000)
	- Фильтр душа загрязнен	- Очистить фильтр
Подмес воды, в закрытом положении горячая вода стремится в подводку холодной воды или наоборот	- Клапан обратного тока воды загрязнен или неисправен	- Очистить кланан или заменить при необходимости
Температура смешанной воды не соответствует шкале	- Термостат не настроен	- Настроить термостат
	- Температура горячей воды слишком низкая	- Поднять температуру горячей воды с 42 град.С до 65 град.С
Регулировка температура не производится	- Регулятор засорен накипью	- Замените регулятор
Из душа или выхода капает вода	- Загрязнения или отложения на уплотнительном кольце, верхняя часть запора повреждена	- Очистите или замените верхнюю часть отключающего устройства
Проточный нагреватель не включается в режиме работы термостата	- Упорное кольцо Ecoston не снято (#95042000)	- Ecoston Снимите упорное кольцо (#95042000)
	- Дроссель не удален из ручного душа	- Извлеките дроссель из ручного душа
	- Грязеулавливающие сита загрязнены	- Очистите / замените грязеулавливающее сито
	- Клапан обратного тока заедает	- Замените клапаны обратного течения



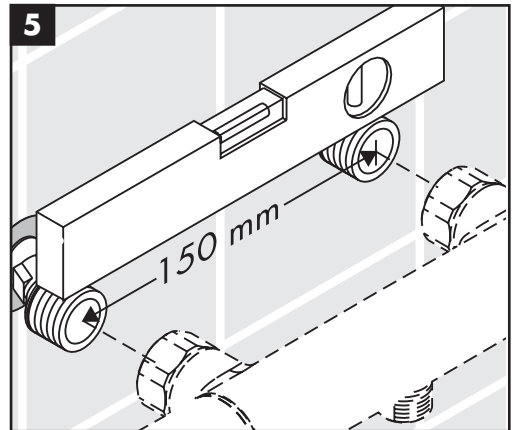
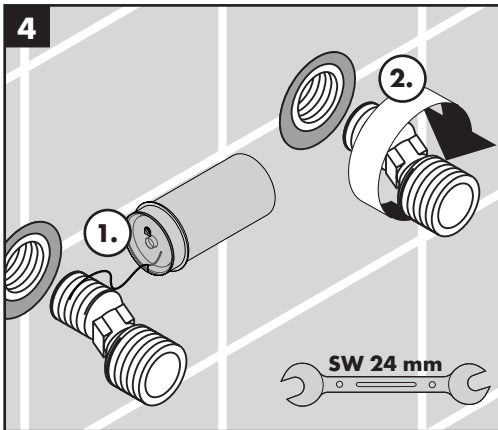
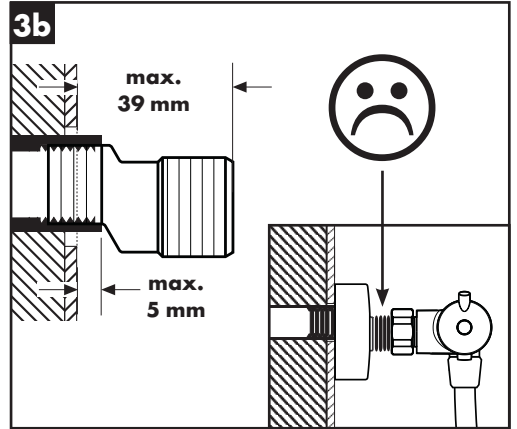
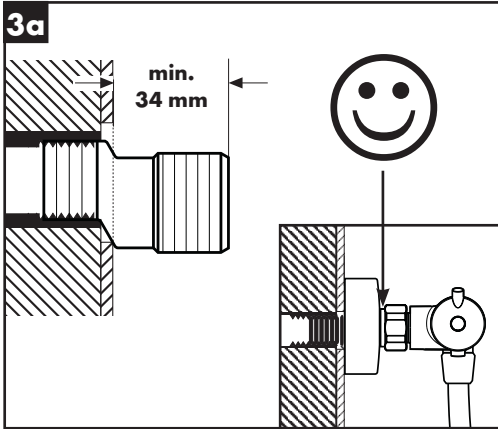
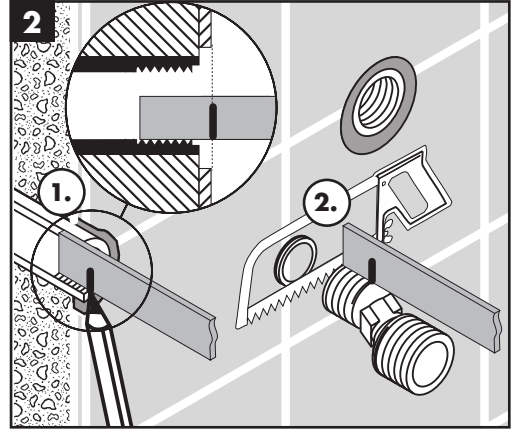
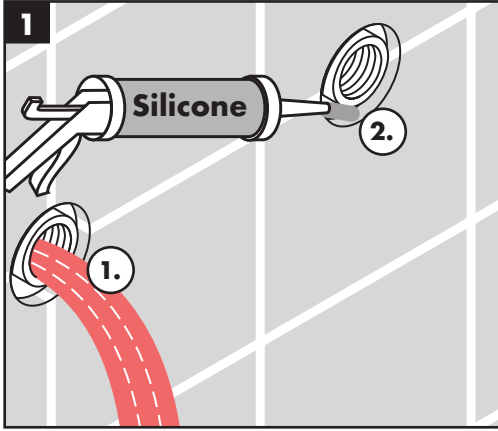

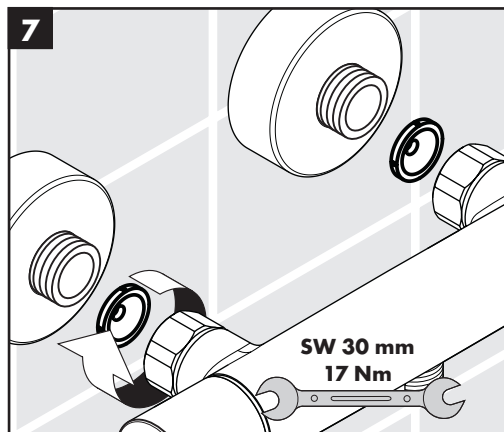
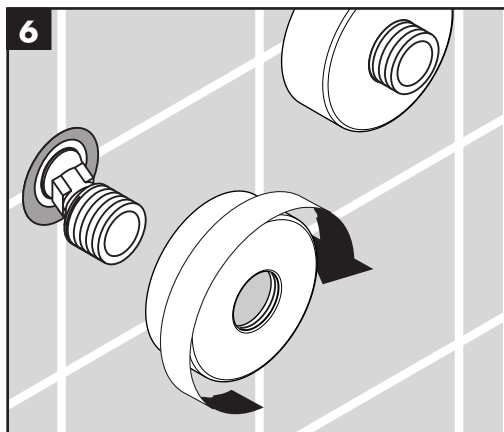

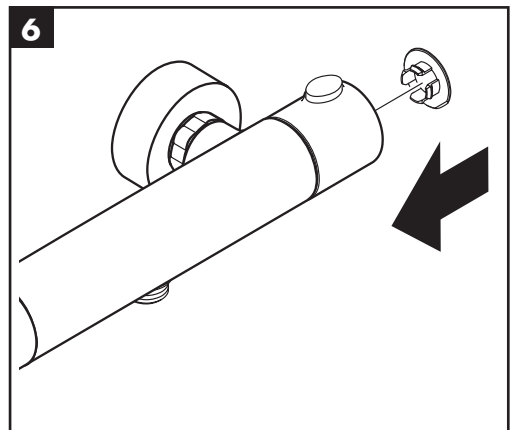
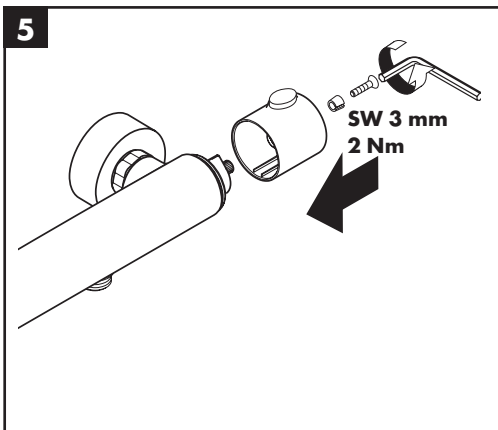
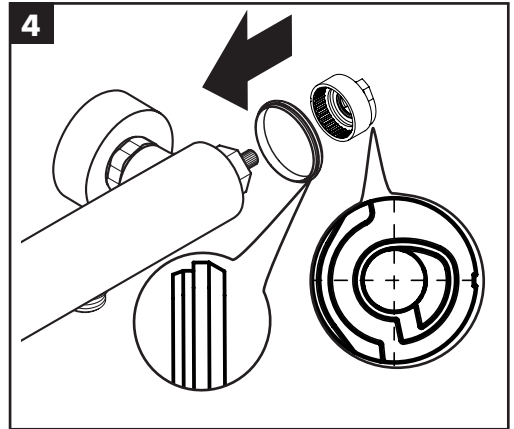
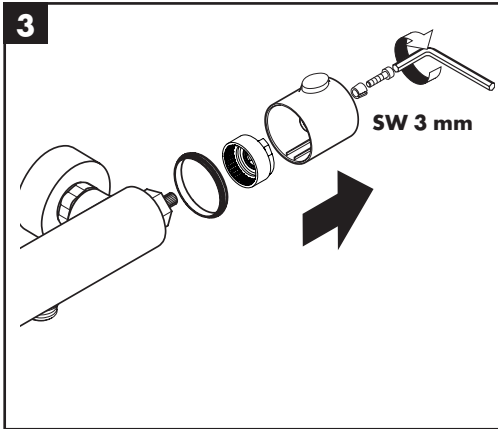
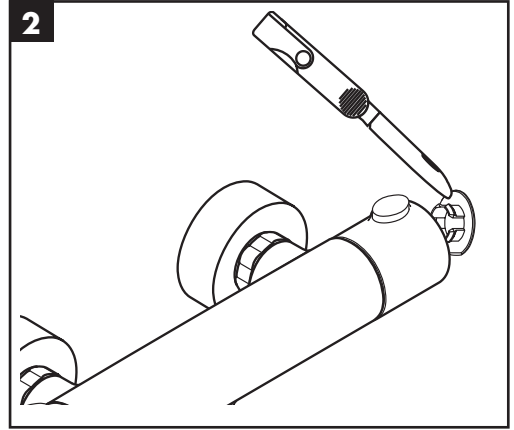
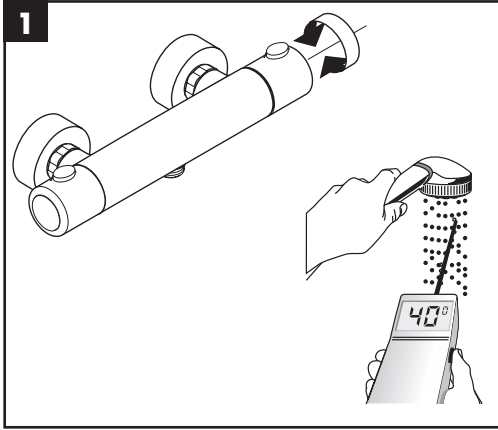

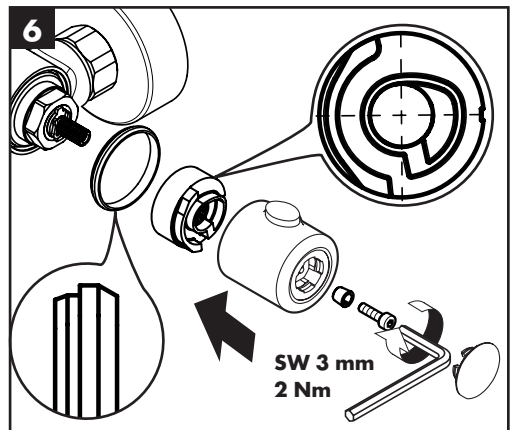
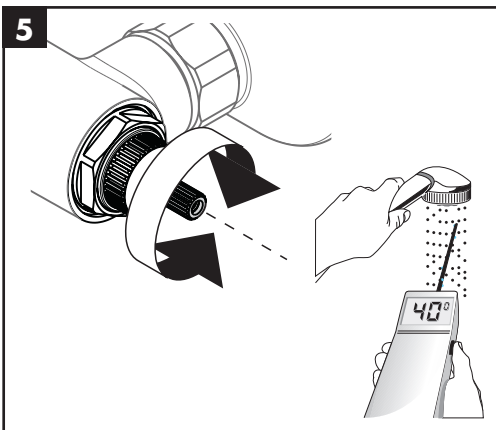
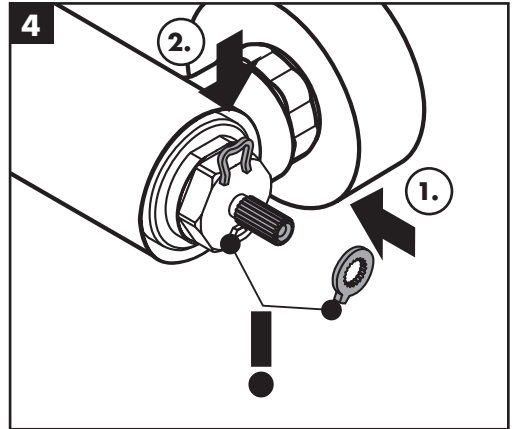
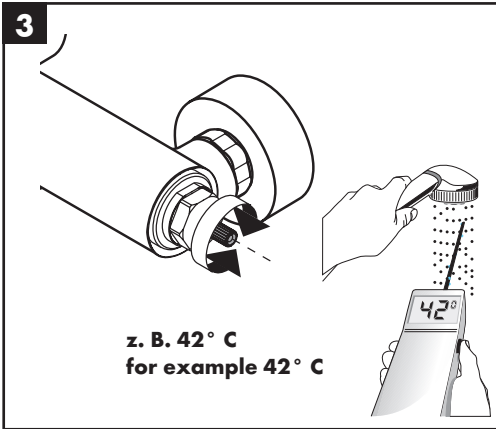
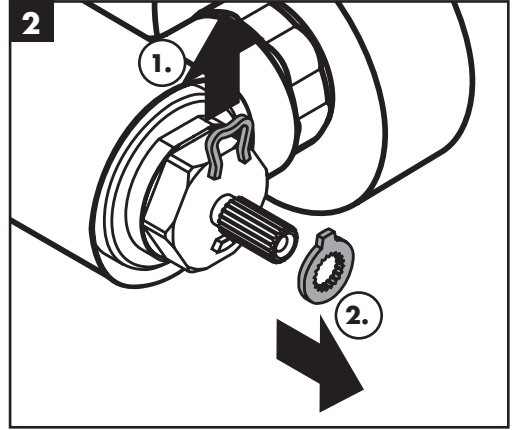
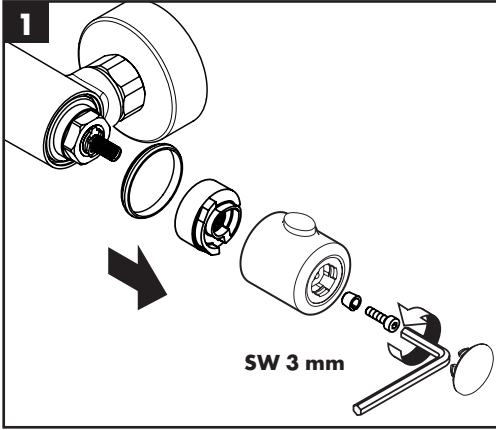

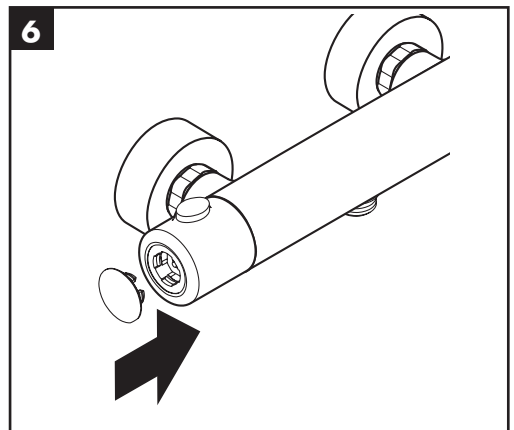
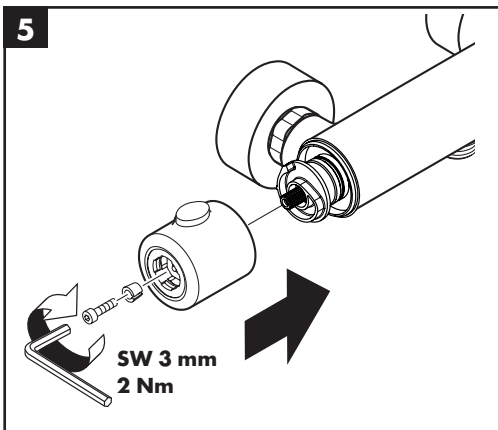
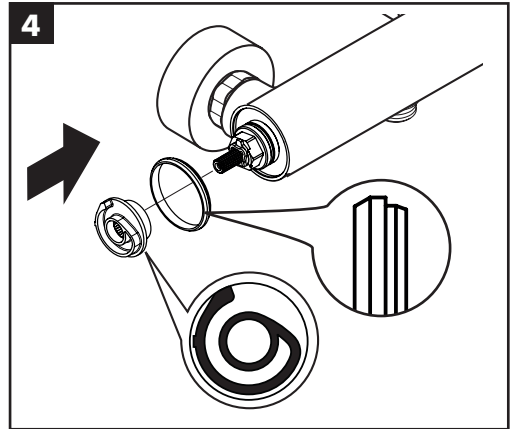
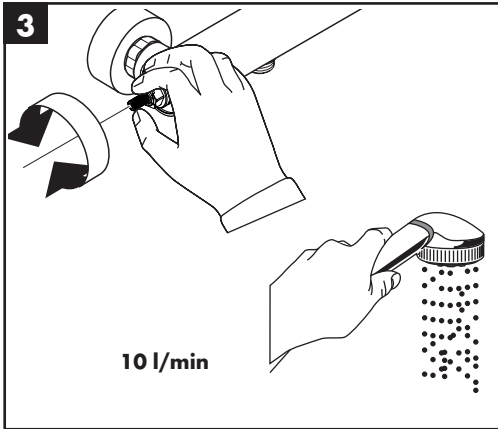
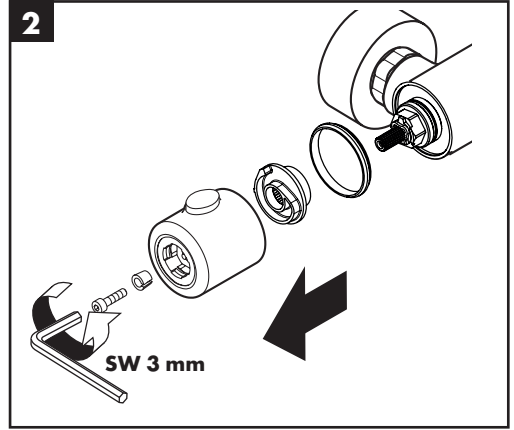
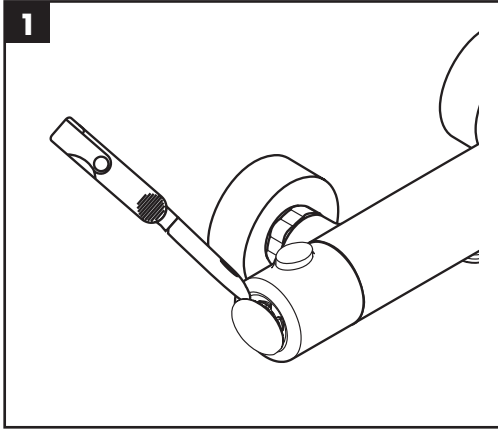

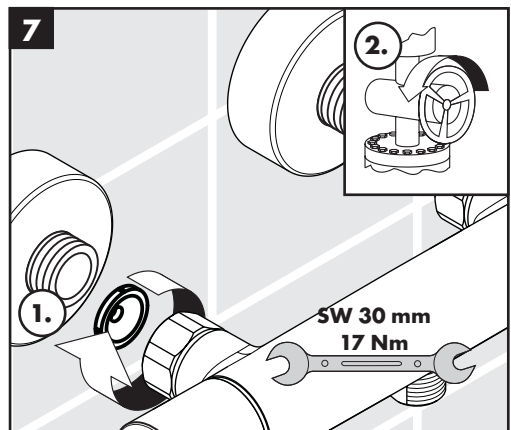
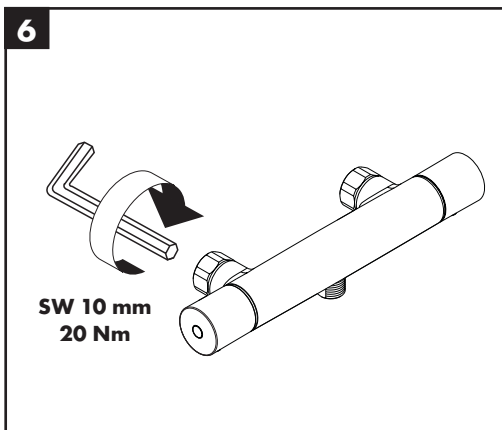
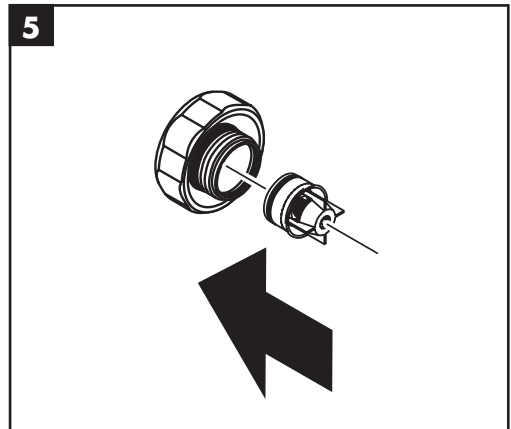
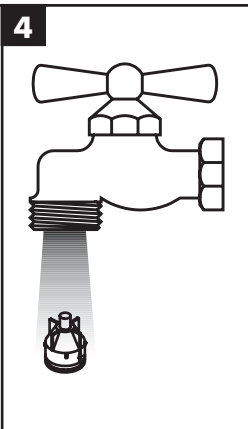
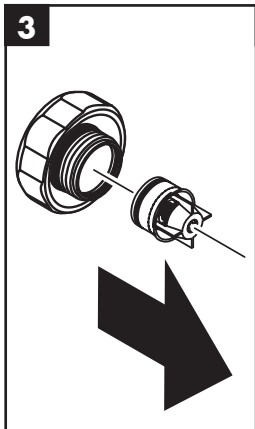
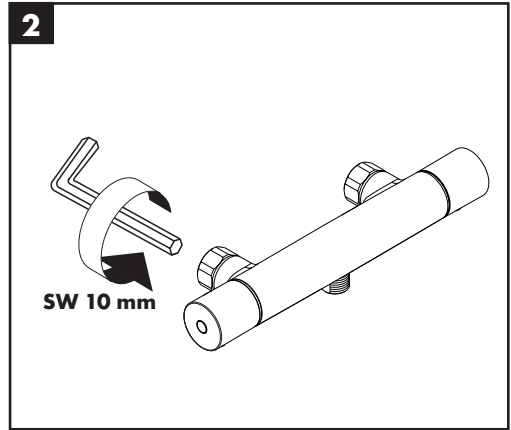
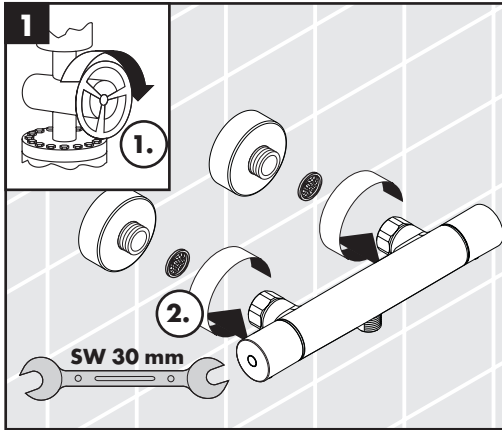
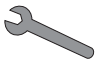



**Mediano**  
14241000

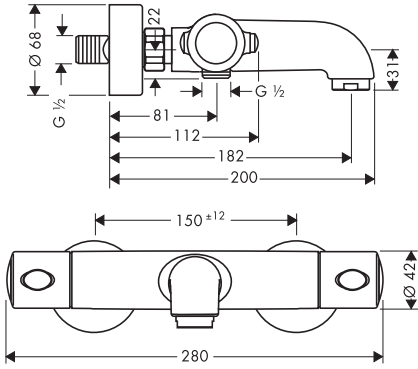

**Mediano**  
14261000

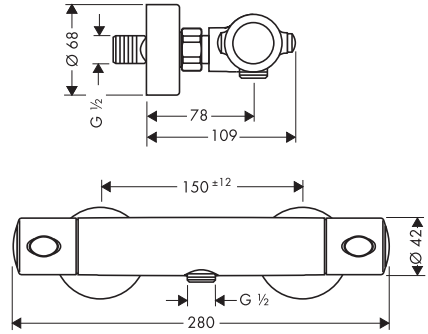

**Mediano**  
14241000

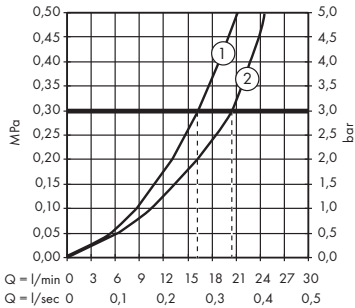

**Mediano**  
14261000

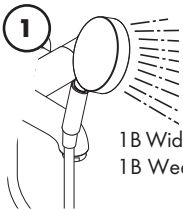
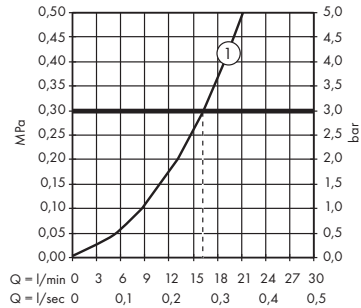

1B Widerstand / 1B résistance / 1B resistance / 1B Resistenza / 1B resistencia /  
1B Weerstand / 1B Modstand / 1B Сопротивление

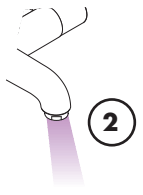



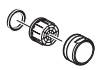

**Mediano**  
14241000

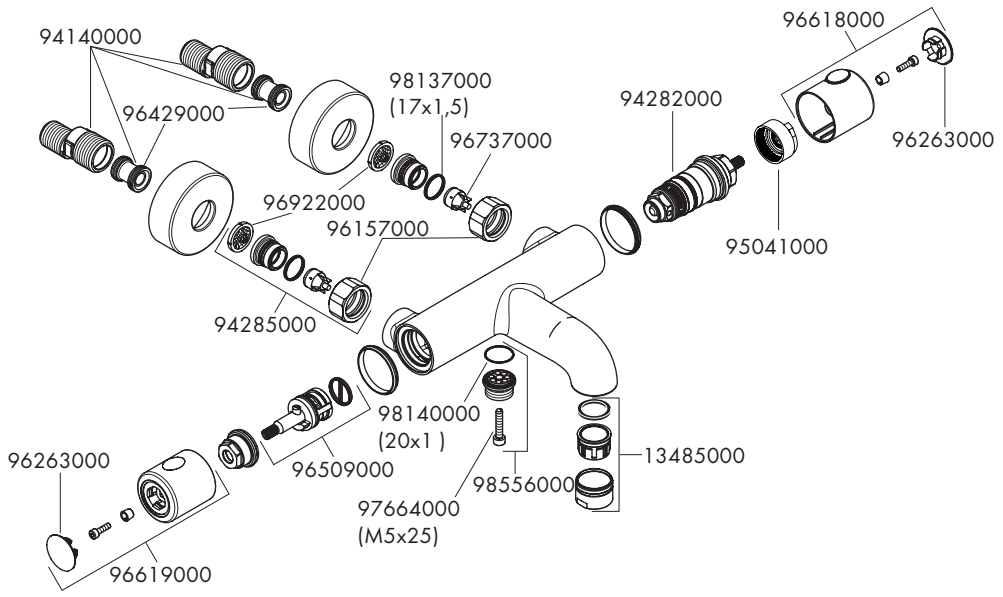

**Mediano**  
14261000

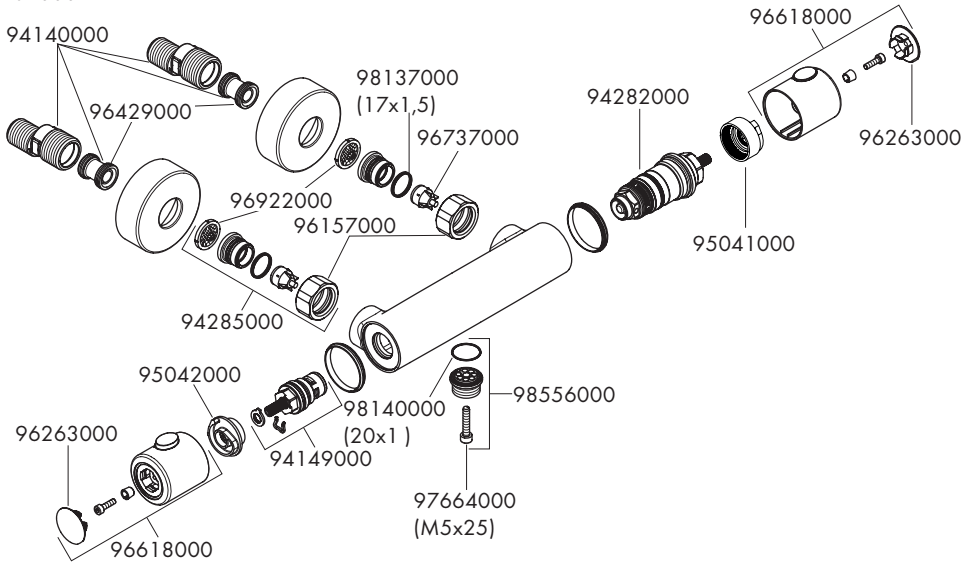

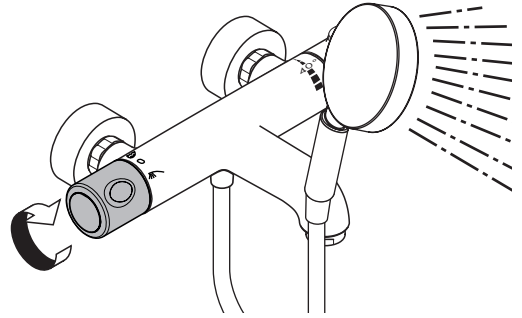
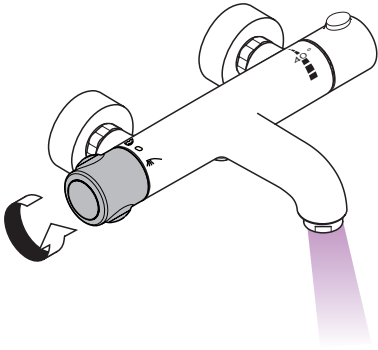

öffnen / ouvert / open / aperto / abierto / open / åbne / открыть

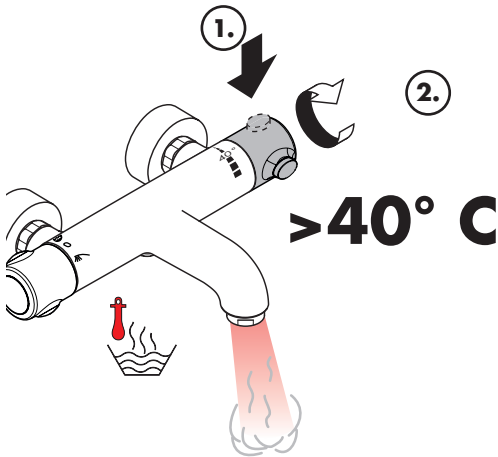

warm / chaud / hot / caldo / caliente / warm / varmt / горячая



kalt / froid / cold / freddo / frío / koud / koldt / холодная

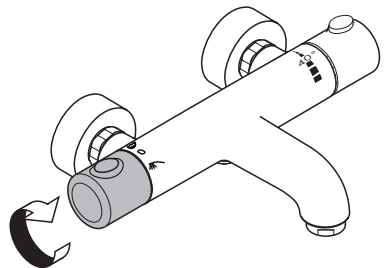

schließen / fermé / close / chiudere / cerrar / sluiten / lukke / закрыть

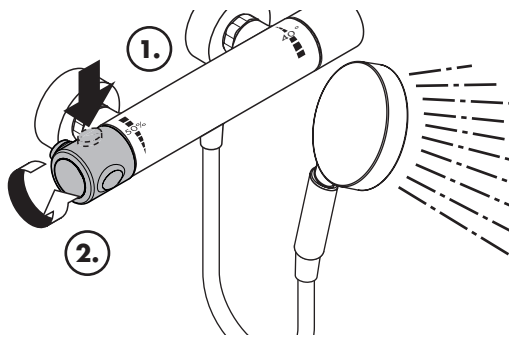
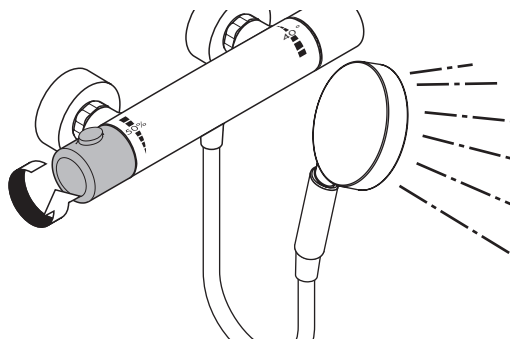

öffnen / ouvert / open / aperto / abierto / open / åbne / открыть

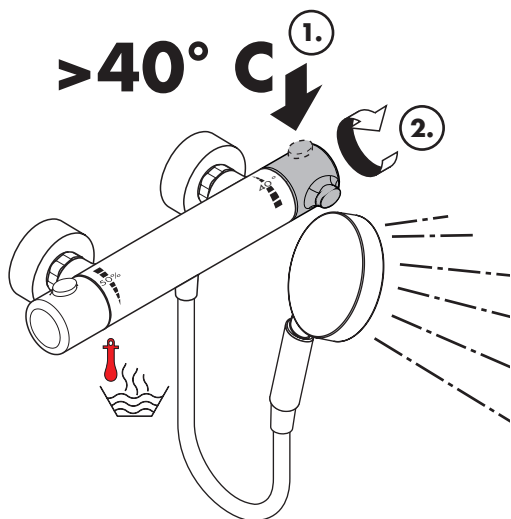

warm / chaud / hot / caldo / caliente / warm / varmt / горячая

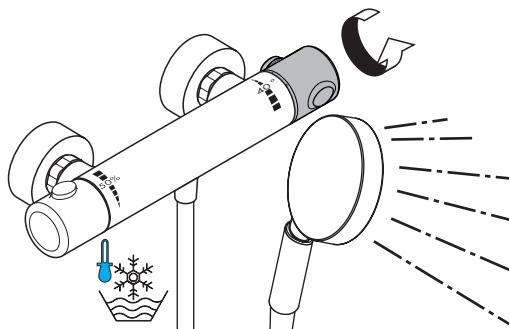

kalt / froid / cold / freddo / frío / koud / koldt / холодная

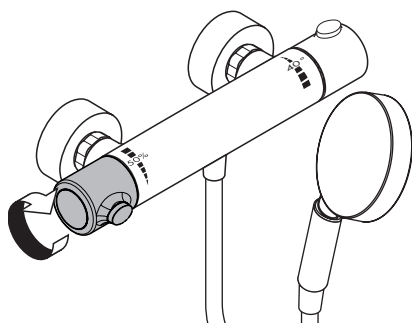

schließen / fermé / close / chiudere / cerrar / sluiten / lukke / закрыть



---

**P-IX**

**SVGW**

**ACS**

**WRAS**

**MCA**

**ETA**

**KIWA**

**NF**

---

**14241000**

PA-IX 9374/IBB

---

**14261000**

---

