

# Montageanleitung



**Unica'B**  
27700XXX



**Unica'B**  
27705XXX

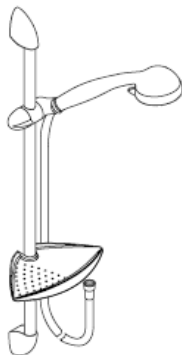

**Selecta/Unica'B**  
27780000/  
27781000



**Selecta 2jet/Unica'B**  
27786000

**hangrohe**



Optimale Funktion nur in Verbindung mit Hansgrohe Handbrausen und Hansgrohe Brausenschläuchen garantiert. Brausenschläuche sind nur zum Anschluss von Brausen an Armaturen geeignet. Eine Absperrung nach dem Schlauch in Fließrichtung ist unzulässig!

**Unica'B 27700XXX**

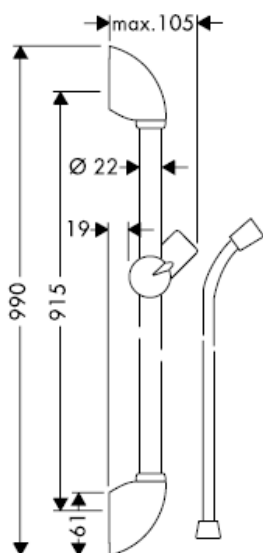

**Unica'B 27705XXX**

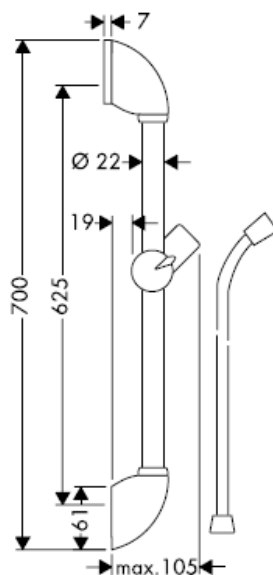

Die Brausestange 27824XXX ist ausschließlich für den Export und somit in Deutschland nicht erhältlich!

**Selecta/Unica'B 27780000**

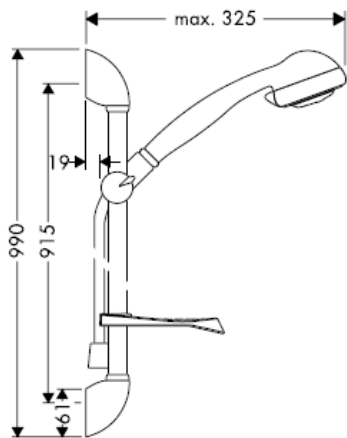

**Selecta/Unica'B 27781000**

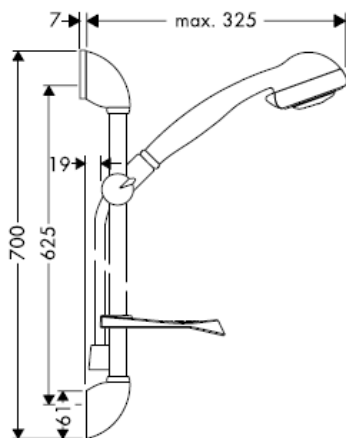

Die Brausestange 27824XXX ist ausschließlich für den Export und somit in Deutschland nicht erhältlich!

**Selecta 2jet/Unica'B 27786000**

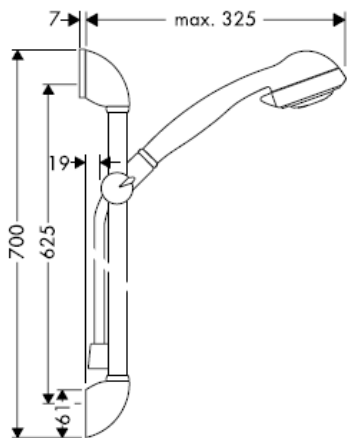

Die Brausestange 27824XXX ist ausschließlich für den Export und somit in Deutschland nicht erhältlich!

## Selecta

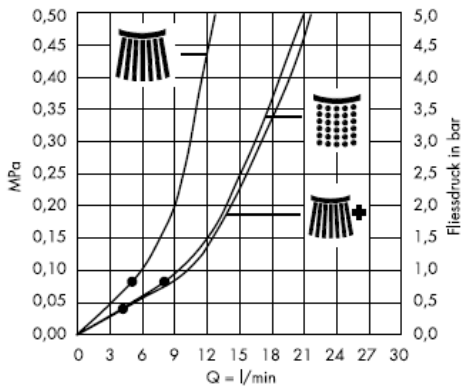

## Selecta 2jet

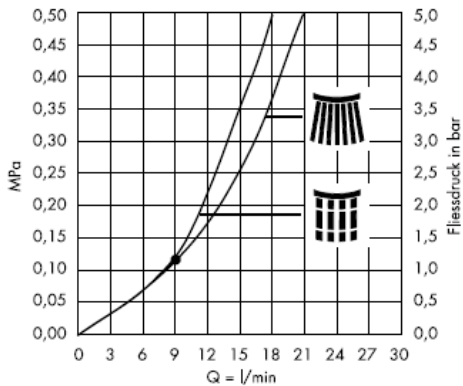

Ab • ist die Funktion gewährleistet.



Normalstrahl



Normalstrahl +  
Waterdimmer®  
(Durchflussbegrenzer)



Softstrahl



Massagestrahl

## Technische Daten

Betriebsdruck:	max. 0,6 MPa
Empfohlener Betriebsdruck: (1 MPa = 10 bar = 147 PSI)	0,1 – 0,4 MPa
Heißwassertemperatur:	max 60°C

Hansgrohe Einhandmischer können in Verbindung mit hydraulisch und thermisch gesteuerten Durchlauferhitzern eingesetzt werden wenn der Fließdruck mindestens 0,15 MPa beträgt.

Bei der Montage des Produktes durch qualifiziertes Fachpersonal ist darauf zu achten, dass die Befestigungsfläche im gesamten Bereich der Befestigung plan ist (keine vorstehenden Fugen oder Fliesenversatz), der Wandaufbau für eine Montage des Produktes geeignet ist und insbesondere keine Schwachstellen aufweist. Die beigelegten Schrauben und Dübel sind nur für Beton geeignet. Bei anderen Wandaufbauten sind die Herstellerangaben des Dübelherstellers zu beachten.

## Prüfzeichen

	DVGW	P-IX	SVGW	ACS	NF	WRAS	KIWA
27700XXX							
27705XXX							
27780000							
27781000				X			
27786000				X			

Die der Brause beige packte Siebdichtung muss eingebaut werden, um Schmutzeinspülungen aus dem Leitungsnetz zu vermeiden. Schmutzeinspülungen können die Funktion beeinträchtigen und/oder zu Beschädigungen an Funktionsteilen der Brause führen, für hieraus ergebende Schäden haftet Hansgrohe nicht.

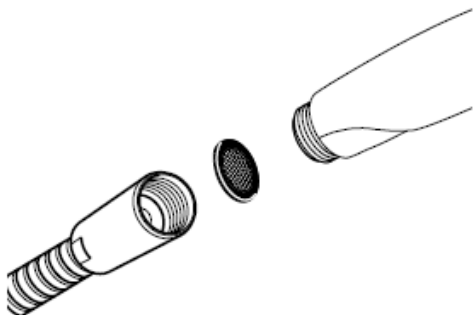

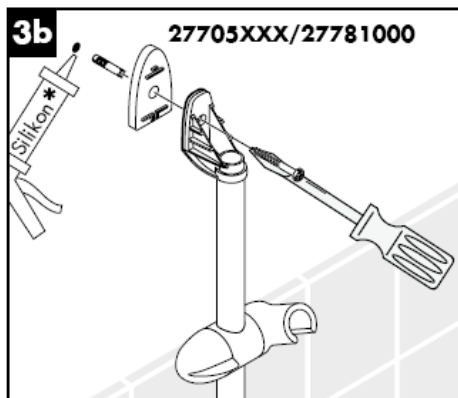
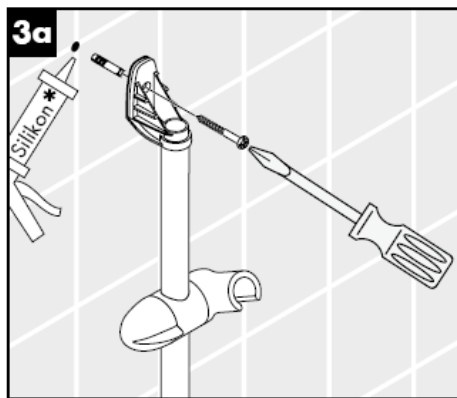
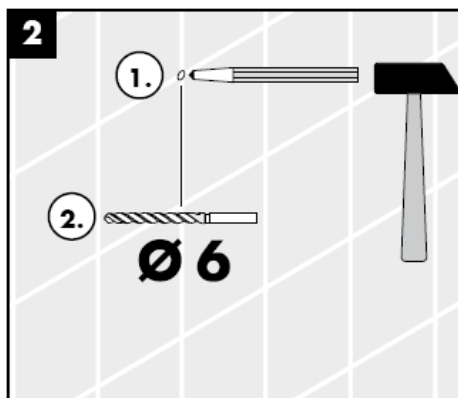
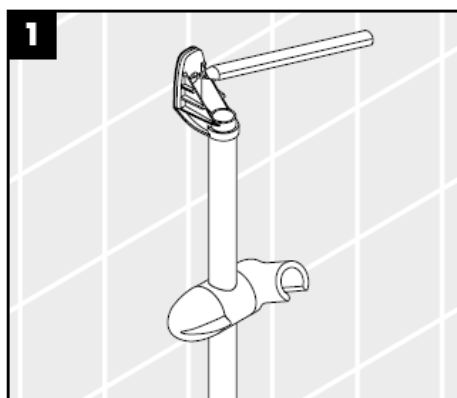

\* Silikon (essigsäurefrei!)

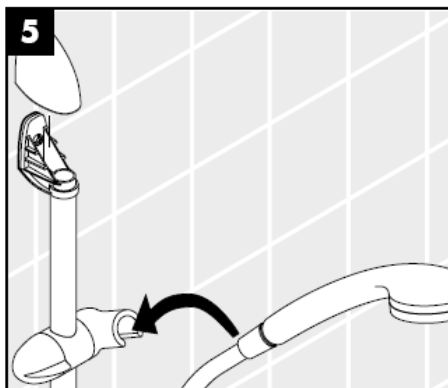
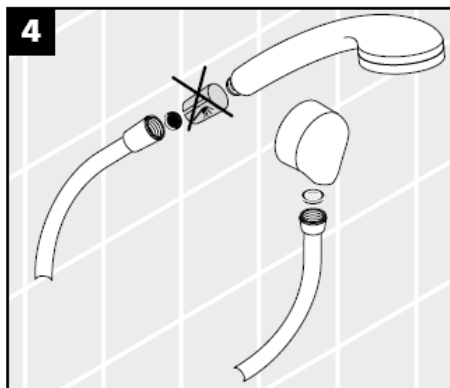

**Cassetta'B** 28686000

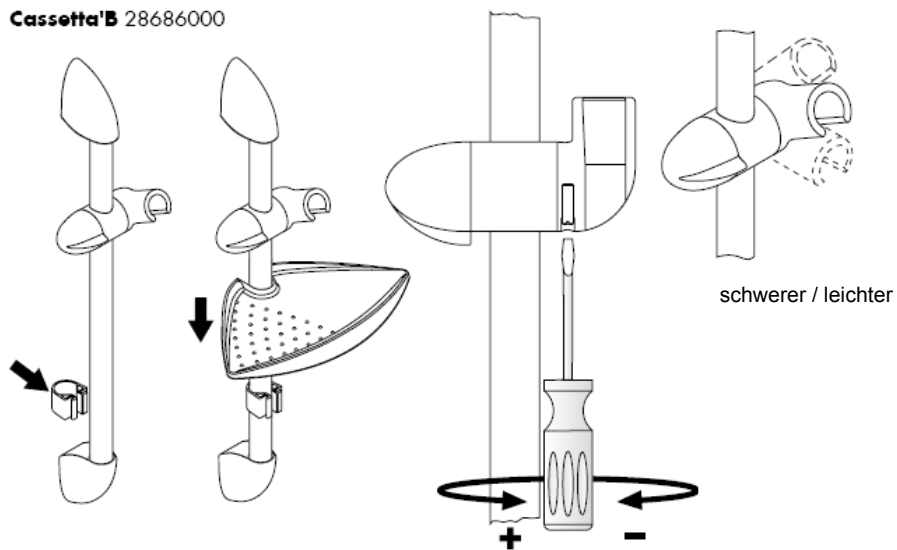

## Reinigung

Mit Rubit®, der manuellen Reinigungsfunktion können die Strahlformer durch einfaches rubbeln vom Kalk befreit werden.



## Pflegeanleitung

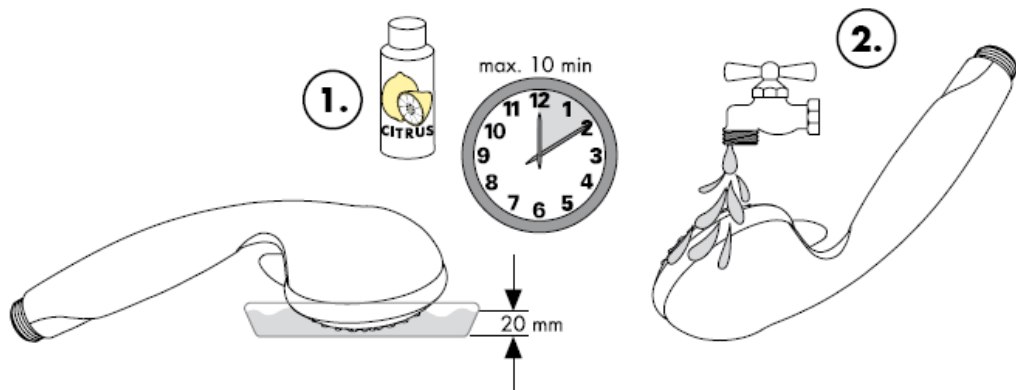

**hansgrohe**

# Instructions de montage



**Unica'B**  
27700XXX



**Unica'B**  
27705XXX

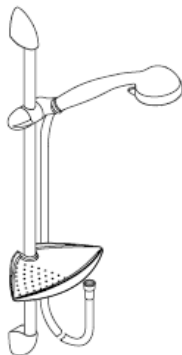

**Selecta/Unica'B**  
27780000/  
27781000



**Selecta 2jet/Unica'B**  
27786000

**hansgrohe**



Un fonctionnement optimal est seulement garanti en combinaison avec des douches à main et des flexibles Hansgrohe. Les flexibles de douche ne doivent être utilisés que pour le raccordement d'une douche à main à un robinet. Le montage d'un système d'arrêt après le flexible, en direction du courant d'eau est strictement interdit.

**Unica'B 27700XXX**

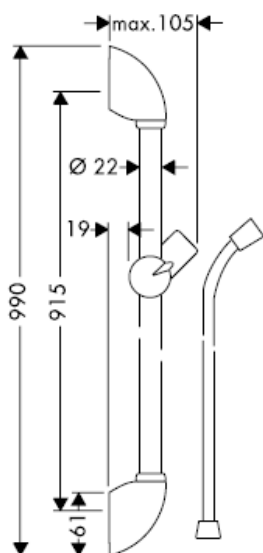

**Unica'B 27705XXX**

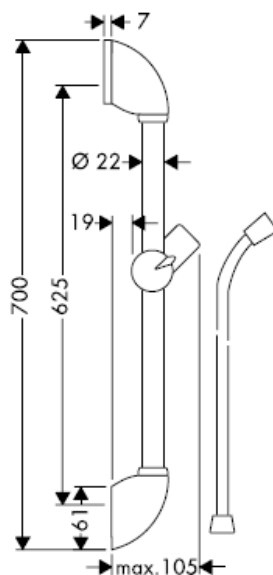

La barre de douche 27824XXX étant exclusivement destinée à l'export, elle n'est pas livrée en Allemagne !

**Selecta/Unica'B 27780000**

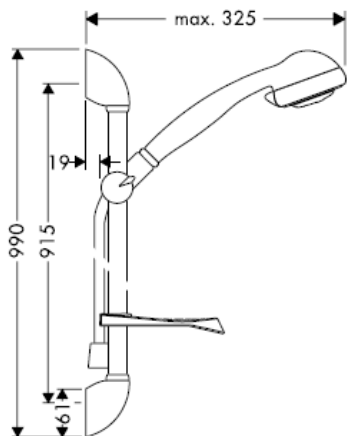

**Selecta/Unica'B 27781000**

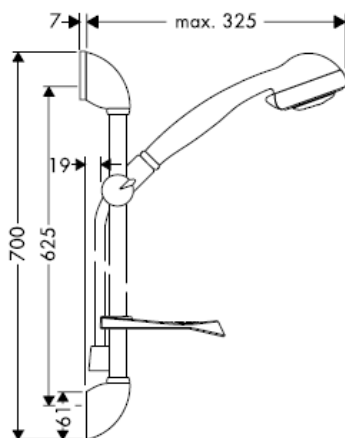

La barre de douche 27824XXX étant exclusivement destinée à l'export, elle n'est pas livrée en

**Selecta 2jet/Unica'B 27786000**

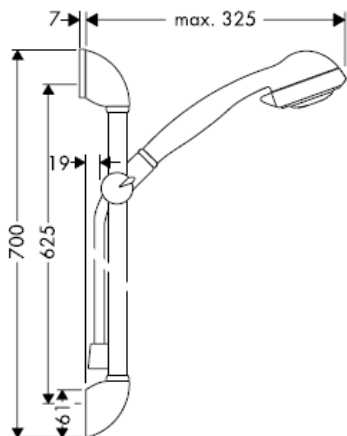

La barre de douche 27824XXX étant exclusivement destinée à l'export, elle n'est pas livrée en Allemagne !

## Selecta

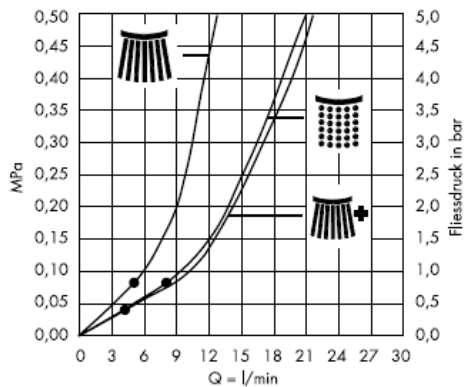

## Selecta 2jet

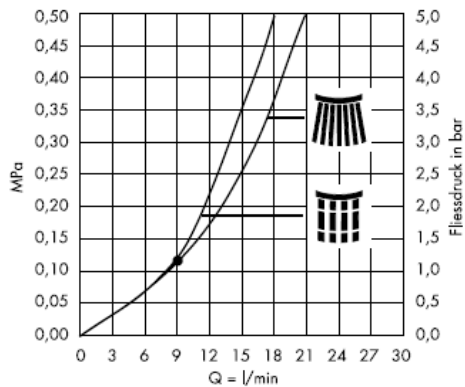

A partir de • le fonctionnement est garanti.



Jet de pluie



Jet de pluie + Limiteur de débit



Jet doux aéré



Jet de massage

## Informations techniques

Pression de service autorisée: max. 0,6 MPa  
Pression de service conseillée: 0,1 – 0,4 MPa  
(1 MPa = 10 bars = 147 PSI)  
Température max. d'eau chaude: max 60°C

Les mitigeurs monocommandes Hansgrohe fonctionnent également en association à des chauffe-eau à commande hydraulique ou thermique à condition que la pression soit au minimum de 0,15 MPa.

Lors du montage du produit par un ouvrier qualifié, il faut faire attention à ce que la surface de fixation soit plane sur toute son étendue (aucun dépassement de joint ni de carrelage), que la construction de la paroi soit adaptée à l'installation du produit et surtout ne présente aucun point faible. Les vis et les chevilles fournies sont uniquement appropriées au béton. Pour les autres constructions, il faudra tenir compte des préconisations du fabricant de cheville.

## Classification acoustique et débit

	DVGW	P-IX	SVGW	ACS	NF	WRAS	KIWA
27700XXX							
27705XXX							
27780000							
27781000				X			
27786000				X			

Le joint à filtre fourni avec la pomme de douche à main doit être installé afin de retenir des impuretés du système de conduites. Ceux-ci pourraient influencer le fonctionnement de ce produit et même endommager des pièces mobiles. Des réclamations à la suite de l'usage de la pomme de douche sans joint-tamis de hansgrohe ne peuvent pas faire partie de notre garantie.

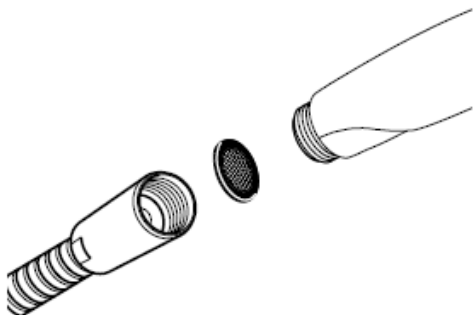

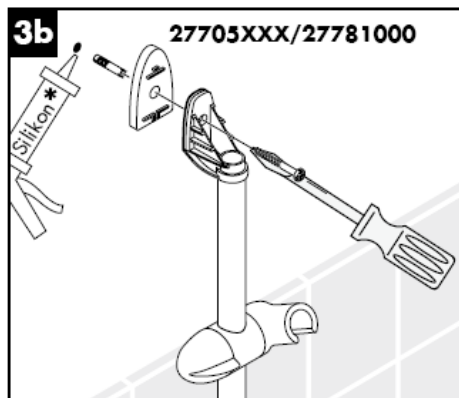
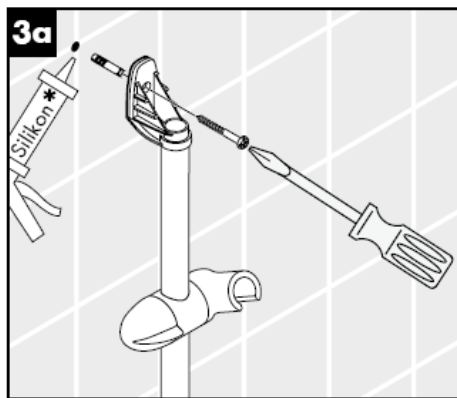
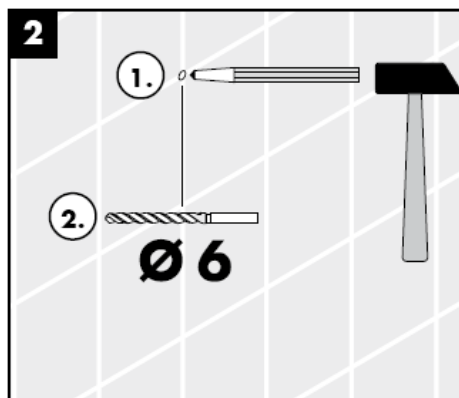
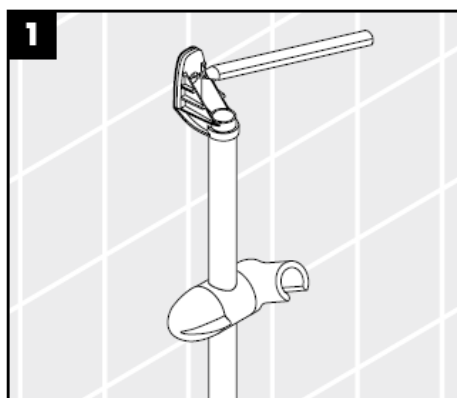

\* Silicone (sans acide acétique!)

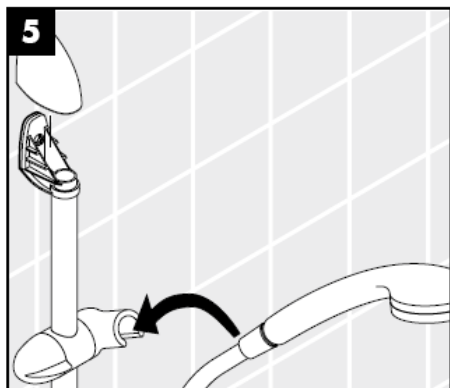
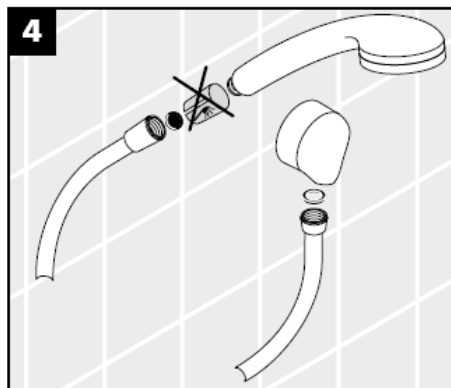

**Cassetta'B** 28686000

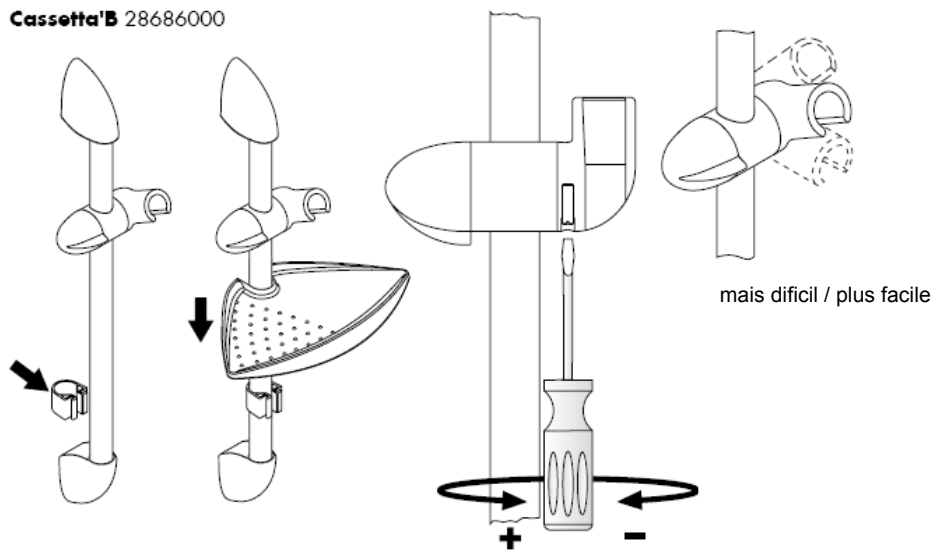

## Nettoyage

La pomme de douche est équipée de Rubit®, le système anticalcaire manuel. Les dépôts de calcaire s'enlèvent en frottant avec un doigt ou avec une éponge sur les ouvertures de jets élastiques.



### Conseils d'entretien

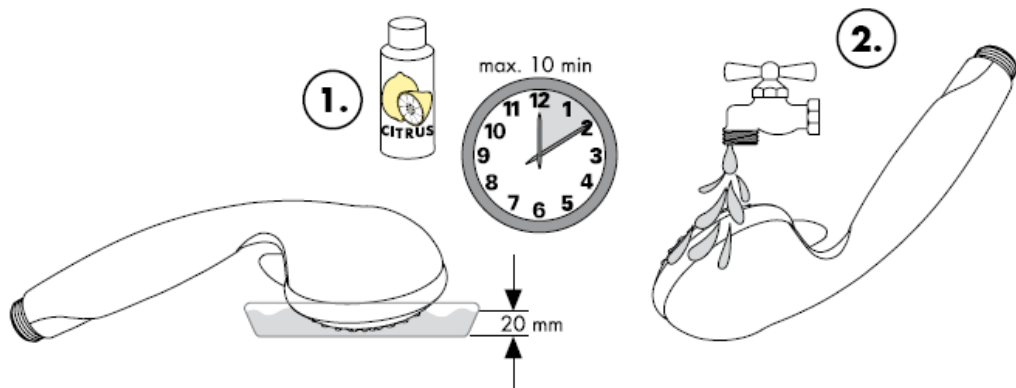

**hansgrohe**

# assembly instructions

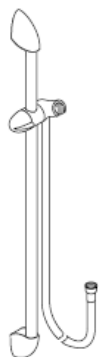

**Unica'B**  
27700XXX



**Unica'B**  
27705XXX

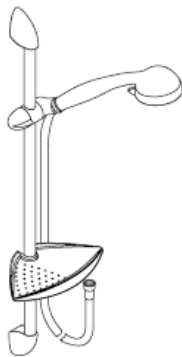

**Selecta/Unica'B**  
27780000/  
27781000



**Selecta 2jet/Unica'B**  
27786000

**hansgrohe**



Optimal functioning is only guaranteed with the combination of Hansgrohe hand showers and Hansgrohe shower hoses. Shower hoses are only suitable for a connection from the shower to the fitting. Never fit a shut-off device between the fitting and the hose.

**Unica'B 27700XXX**

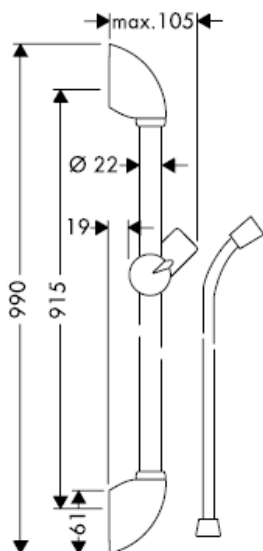

**Unica'B 27705XXX**

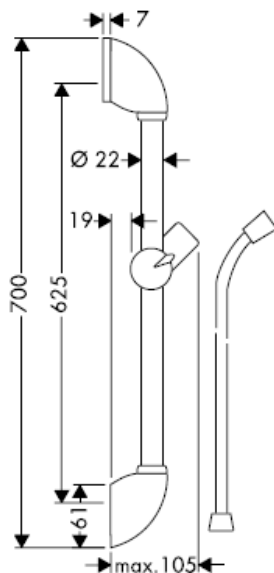

The shower bar 27824XXX is for export only. It is thus not available in Germany!

**Selecta/Unica'B 27780000**

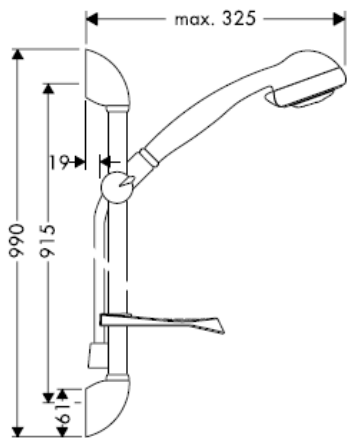

**Selecta/Unica'B 27781000**

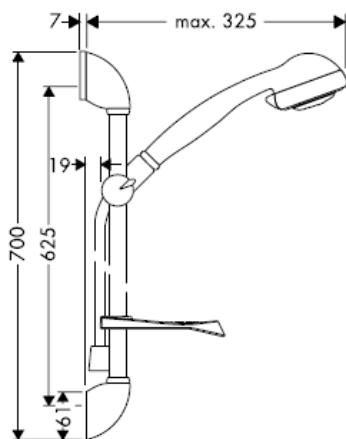

The shower bar 27824XXX is for export only. It is thus not available in Germany!

**Selecta 2jet/Unica'B 27786000**

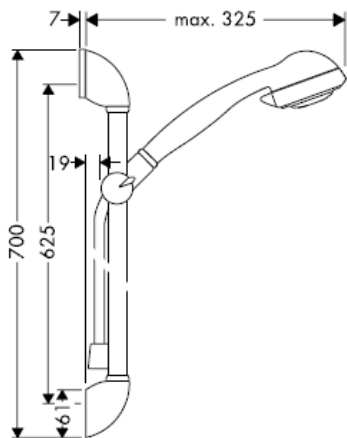

The shower bar 27824XXX is for export only. It is thus not available in Germany!

## Selecta

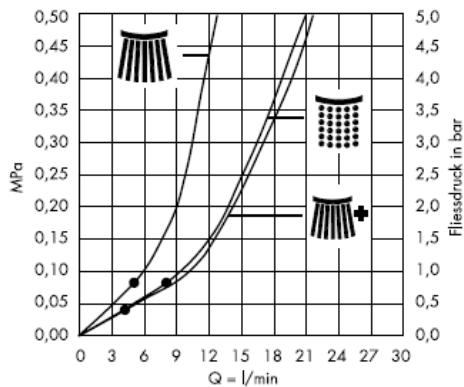

## Selecta 2jet

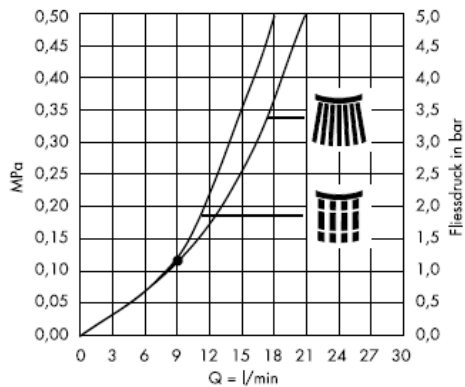

From • the function is guaranteed.



Normal spray



Normal spray + Flow limiter



Soft spray



Massge jet

---

## Technical Data

Operating pressure: max. 0,6 MPa  
Recommended operating pressure: 0,1 – 0,4 MPa  
(1 MPa = 10 bars = 147 PSI)  
Hot water temperature: max 60°C

Hansgrohe single lever mixers can be used together with hydraulically and thermally controlled continuous flow heaters if the flow pressure is at least 0,15 MPa.

Where the contractor mounts the product, he should ensure that the entire area of the wall to which the mounting plate is to be fitted, is flat (no projecting joints or tiles sticking out), that the structure of the wall is suitable for the installation of the product and has no weak points.

The enclosed screws and dowels are only suitable for concrete. For another wall constructions the manufacturer's indications of the dowel manufacturer have to be taken into account.

## Test certificate

	DVGW	P-IX	SVGW	ACS	NF	WRAS	KIWA
27700XXX							
27705XXX							
27780000							
27781000				X			
27786000				X			

The mesh washer must be insert to protect the overhead shower against incoming dirt by pipework. Incoming dirt leads to defects or/and can damage parts of the shower; such caused faults voids all liability and guarantee claims.

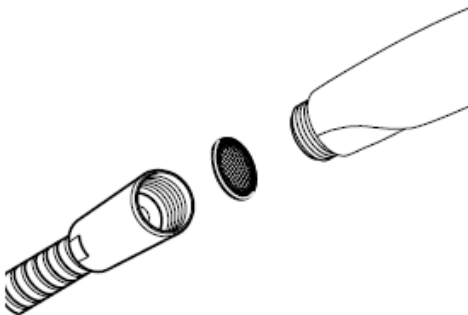

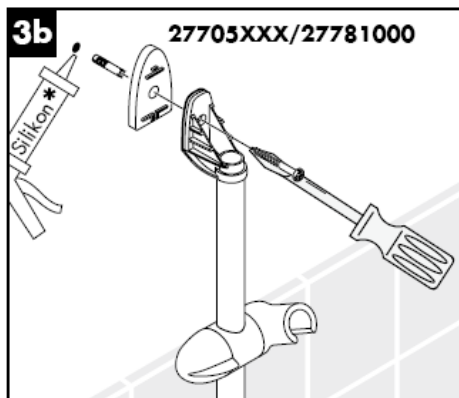
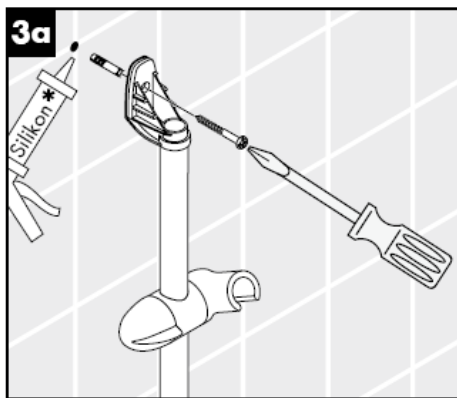
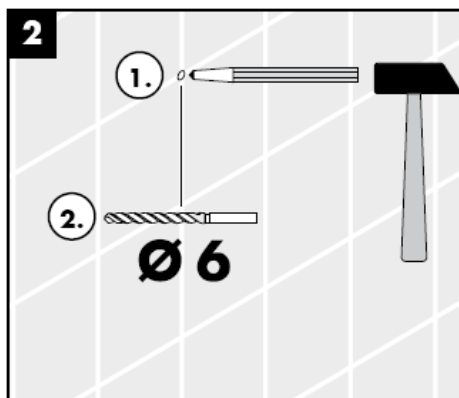
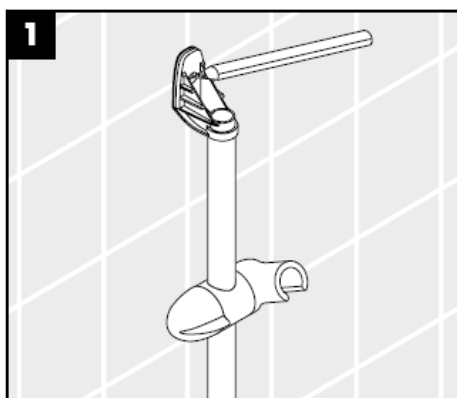

\* Silicone (free from acetic acid!)

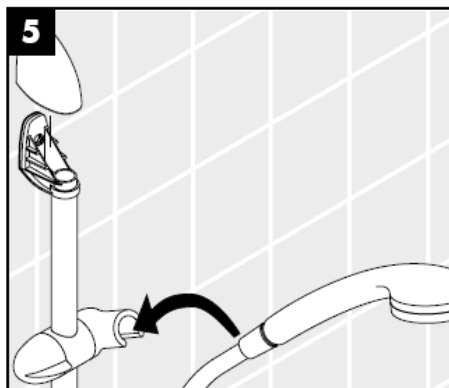
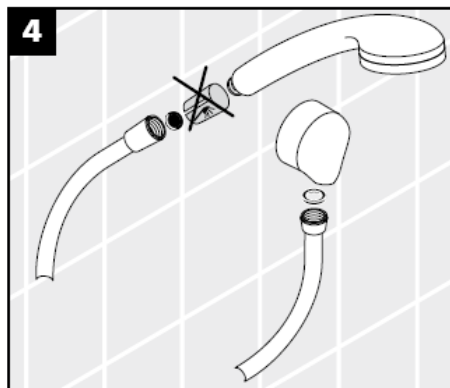

**Cassetta'B** 28686000

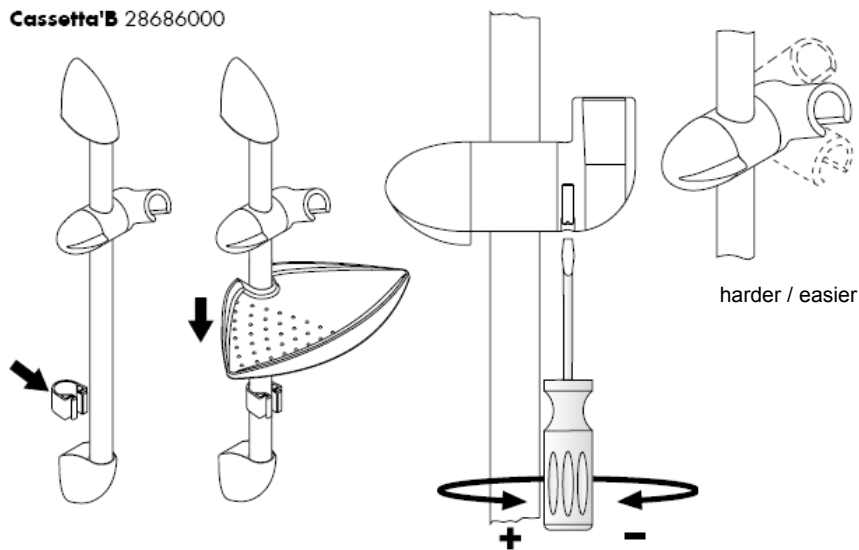

## Cleaning

The Rubit® cleaning function only needs a small manual rub over to remove the lime scale from the spray channels.



### Cleaning instructions

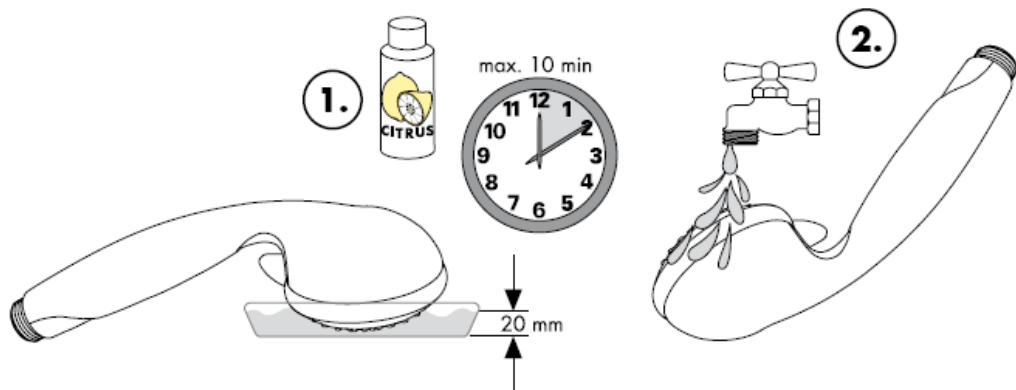

**hansgrohe**

# Istruzioni per Installazione

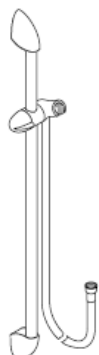

**Unica'B**  
27700XXX



**Unica'B**  
27705XXX



**Selecta/Unica'B**  
27780000/  
27781000



**Selecta 2jet/Unica'B**  
27786000

**hansgrohe**



Funzionalità ottimale solamente in combinazione con doccette e flessibili Hansgrohe. I flessibili devono essere inseriti solo tra l'uscita dell'acqua e la doccetta. Non deve essere introdotta alcuna prolunga tra il flessibile e l'uscita dell'acqua.

**Unica'B 27700XXX**

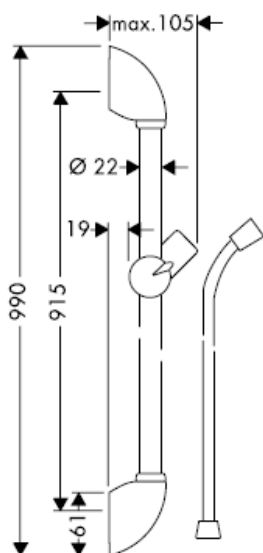

**Unica'B 27705XXX**

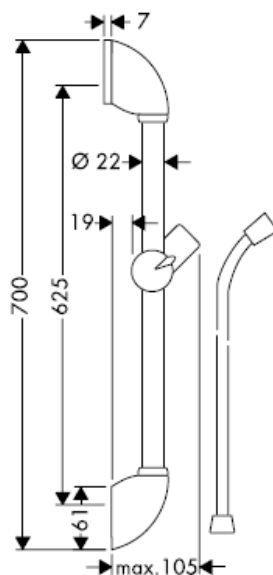

L'asta murale 27824XXX è disponibile esclusivamente per l'esportazione e quindi non è disponibile in Germania!

**Selecta/Unica'B 27780000**

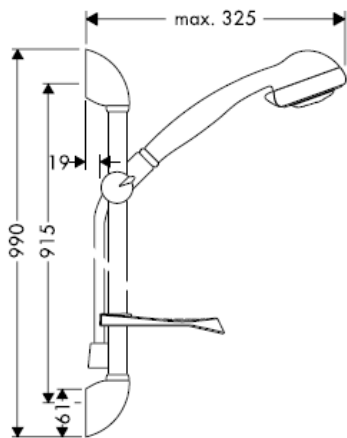

**Selecta/Unica'B 27781000**

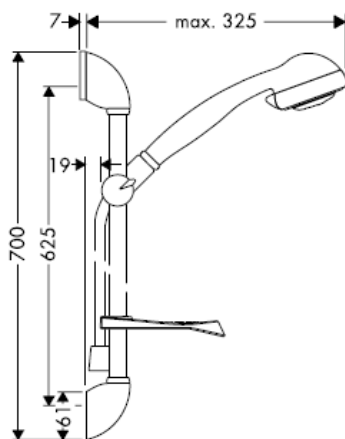

L'asta murale 27824XXX è disponibile esclusivamente per l'esportazione e quindi non è disponibile in

**Selecta 2jet/Unica'B 27786000**

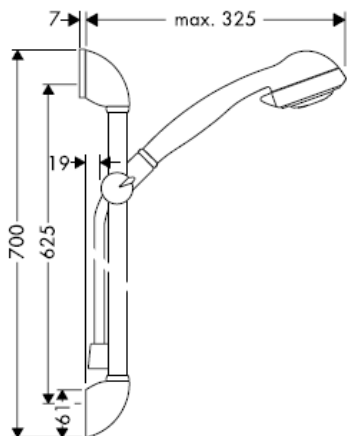

L'asta murale 27824XXX è disponibile esclusivamente per l'esportazione e quindi non è disponibile in

## Selecta

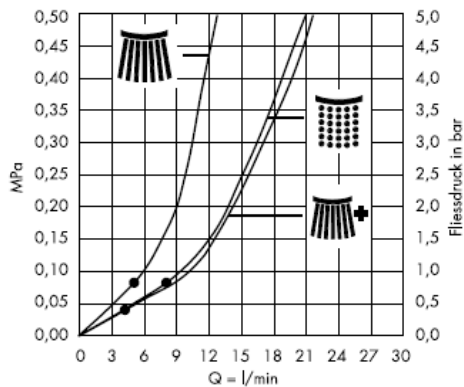

## Selecta 2jet

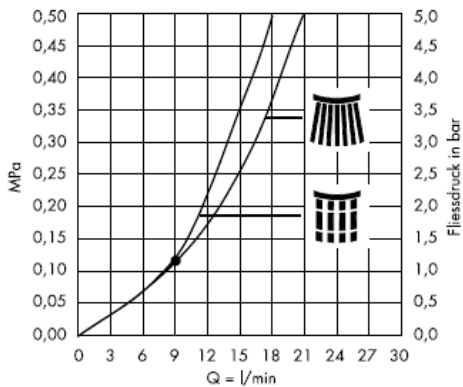

Dal • si garantisce la funzionalità.



Getto normale a pioggia



Getto normale a pioggia + Riduttore di portata



Getto areato



Getto massaggio

## Dati tecnici

Pressione d'uso:	max. 0,6 MPa
Pressione d'uso consigliata: (1 MPa = 10 bar = 147 PSI)	0,1 – 0,4 MPa
Temperatura dell'acqua calda:	max 60°C

I miscelatori Hansgrohe possono venire usati con caldaie a "bassa pressione" se la pressione del flusso è almeno di 0,15 MPa.

**Quando il personale tecnico specializzato esegue il montaggio del prodotto è necessario assicurarsi che la superficie di fissaggio sia piana in tutta l'area di fissaggio (senza giunti sporgenti o spostamento delle piastrelle), che la struttura della parete sia adatta per il montaggio del prodotto e soprattutto che non ci siano dei punti deboli. Le viti e i tasselli in dotazione sono adatti solo per calcestruzzo. In caso di altre strutture della parete vanno osservare le indicazioni del produttore dei tasselli.**

## Segno di verifica

	DVGW	P-IX	SVGW	ACS	NF	WRAS	KIWA
27700XXX							
27705XXX							
27780000							
27781000				X			
27786000				X			

Per proteggere la soffione doccia da eventuali impurità provenienti dalle tubazioni dell'acqua, deve essere inserito il filtro nell'impugnatura della doccia stessa. Tali impurità possono infatti causare difetti e/o danneggiare parti della doccia; in questo caso la Hansgrohe non risponde dei danni.

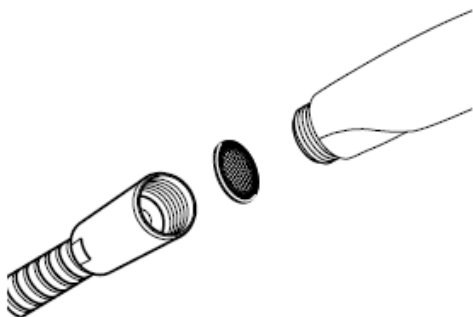

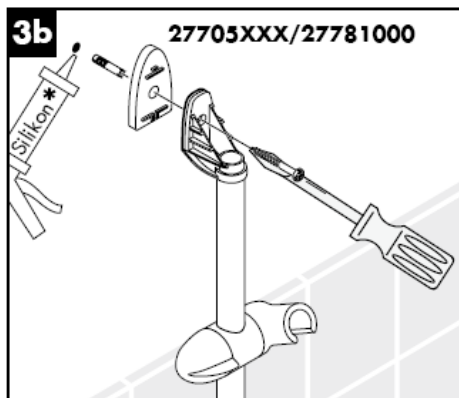
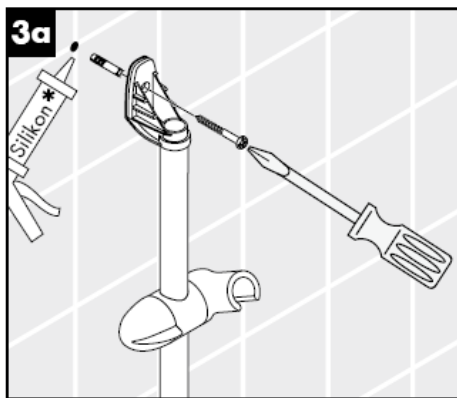
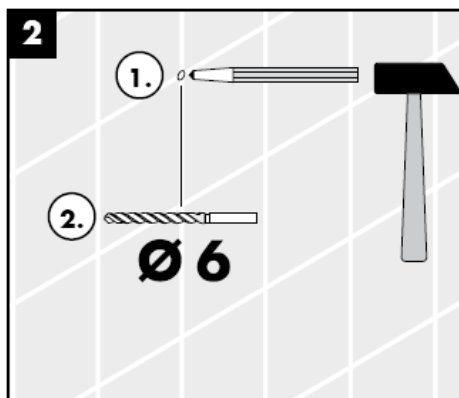
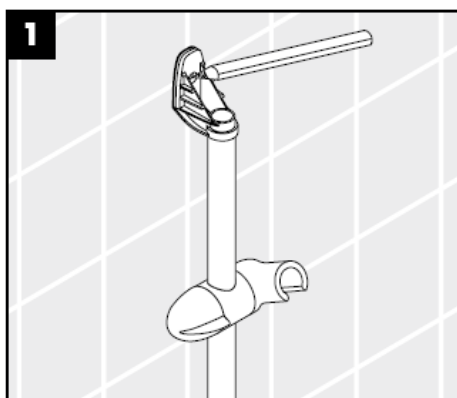

\* Silicone (esente da acido acetico!)

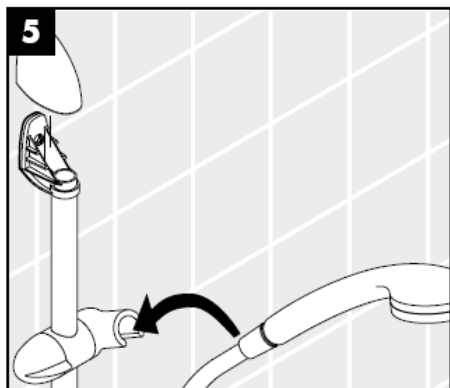
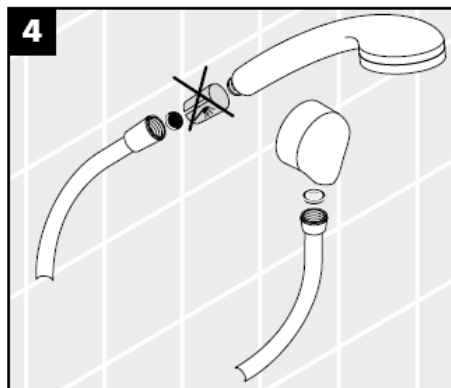

**Cassetta'B** 28686000

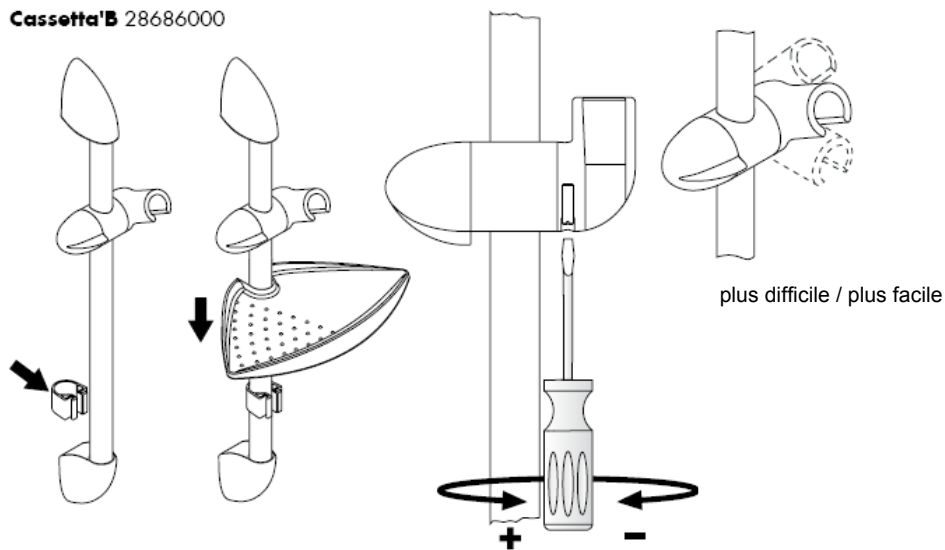

## Pulitura

Con Rubit®, la funzione anticalcare manuale, i diffusori del getto possono essere liberati da calcare con un semplice strofinamento.



### Istruzioni per il trattamento

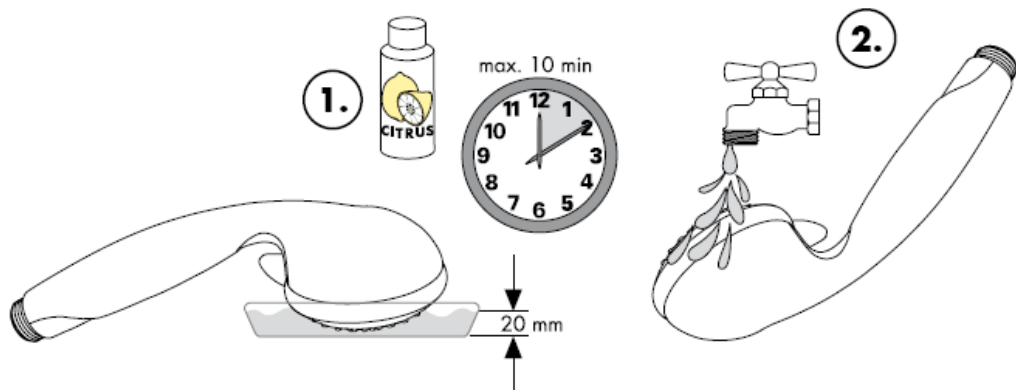

**hansgrohe**

# Instrucciones de montaje



**Unica'B**  
27700XXX



**Unica'B**  
27705XXX

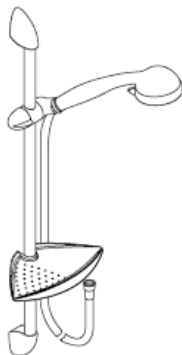

**Selecta/Unica'B**  
27780000/  
27781000



**Selecta 2jet/Unica'B**  
27786000

**hansgrohe**



Sólo se garantiza una función óptima en combinación con teleduchas y flexos de Hansgrohe. Los flexos deben usarse exclusivamente para la conexión entre grifería y teleducha. Cualquier función de cierre tras el flexo y en la dirección del flujo del agua no está permitida.

**Unica'B 27700XXX**

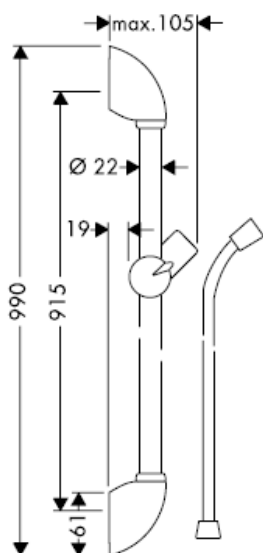

**Unica'B 27705XXX**

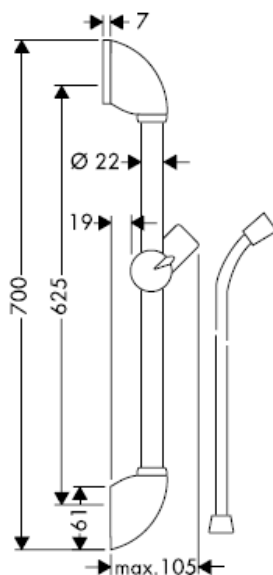

La barra de sujeción de surtidor de ducha 27824XXX es exclusivamente para la exportación y por lo tanto no está disponible en Alemania

**Selecta/Unica'B 27780000**

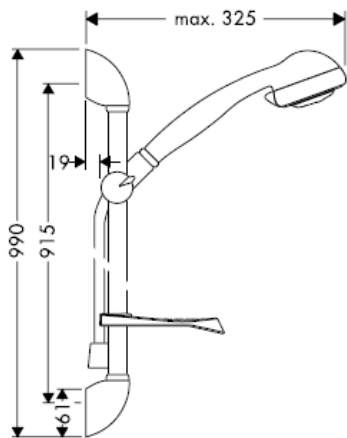

**Selecta/Unica'B 27781000**

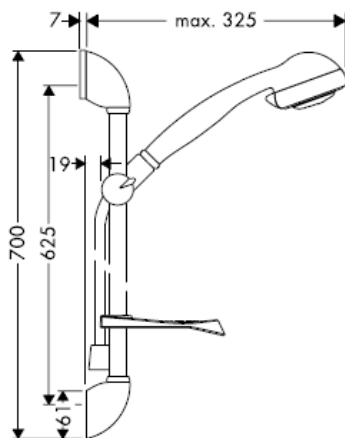

La barra de sujeción de surtidor de ducha 27824XXX es exclusivamente para la exportación y por lo

**Selecta 2jet/Unica'B 27786000**

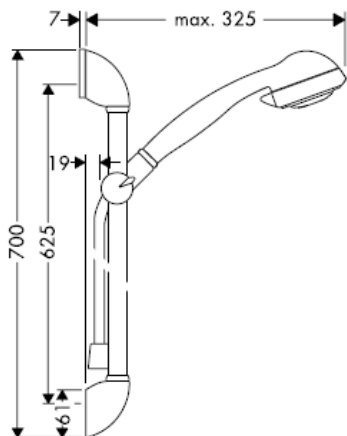

La barra de sujeción de surtidor de ducha 27824XXX es exclusivamente para la exportación y por lo tanto

## Selecta

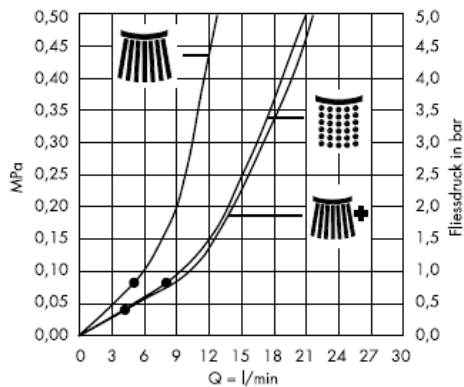

## Selecta 2jet

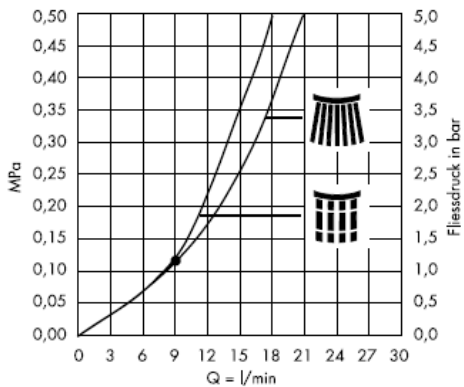

Mínimo • para el correcto funcionamiento.



Chorro de lluvia



Chorro de lluvia +  
Limitador de caudal



Chorro espumoso



Chorro masaje

## Datos técnicos

Presión en servicio: max. 0,6 MPa  
Presión recomendada en servicio: 0,1 – 0,4 MPa  
(1 MPa = 10 bares = 147 PSI)  
Temperatura del agua caliente: max 60°C

Los mezcladores Hansgrohe pueden ser utilizado junto con calentadores continuos de agua que sean manejados de manera hidráulica o térmica, siempre que la presión del caudal ascienda a un mínimo de 0,15 MPa.

En el momento del montaje del producto por parte de personal especializado y cualificado se deberá prestar una atención especial a que la superficie de fijación en toda el área de la fijación sea plana (sin juntas que sobresalen ni azulejos desplazados), que la estructura de la pared sea adecuada para un montaje del producto y que, ante todo, no presente puntos débiles. Los tornillos y tacos adjuntos son sólo apropiados para hormigón. En el caso de otras estructuras murales se deberán considerar las indicaciones del fabricante de tacos.

## Marca de verificación

	DVGW	P-IX	SVGW	ACS	NF	WRAS	KIWA
27700XXX							
27705XXX							
27780000							
27781000				X			
27786000				X			

La junta de filtración que se suministra con la ducha mural evita que las partículas de suciedad procedentes de las tuberías lleguen a la ducha mural. Debe colocarse entre el flexo y la ducha mural. Infiltraciones de suciedad deterioran el funcionamiento de la ducha mural y pueden causar daños en el interior de la misma que no están cubiertas por la garantía de Hansgrohe.

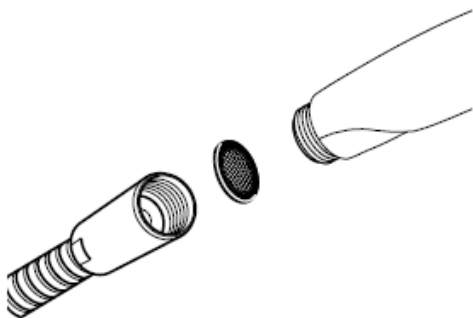

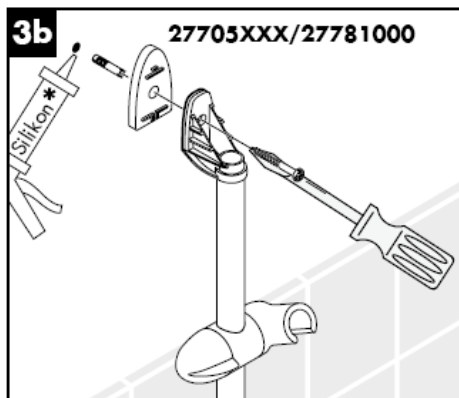
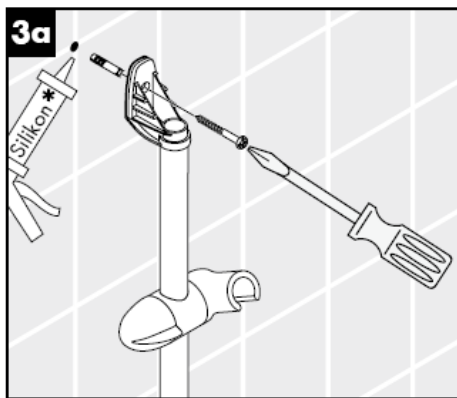
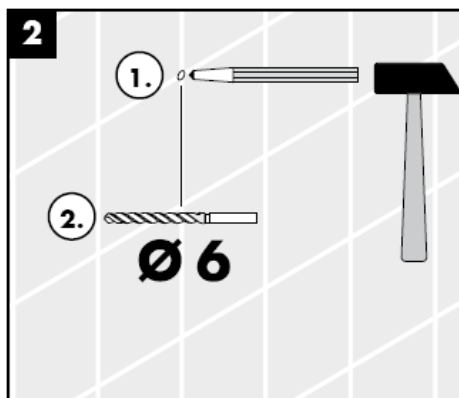
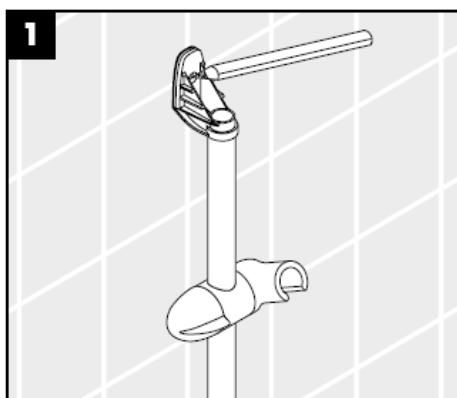

\* Silicona (¡libre de ácido acético!)

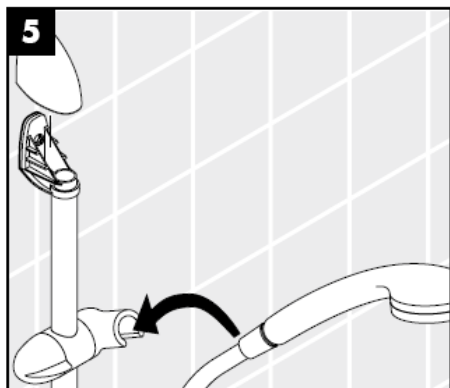
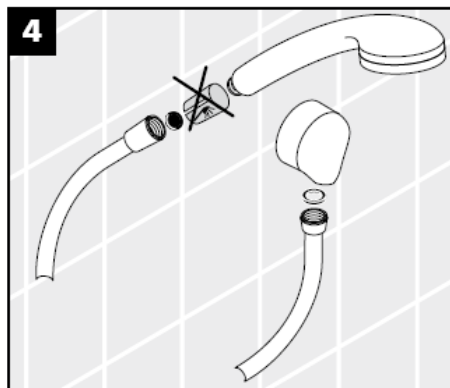

**Cassetta'B** 28686000

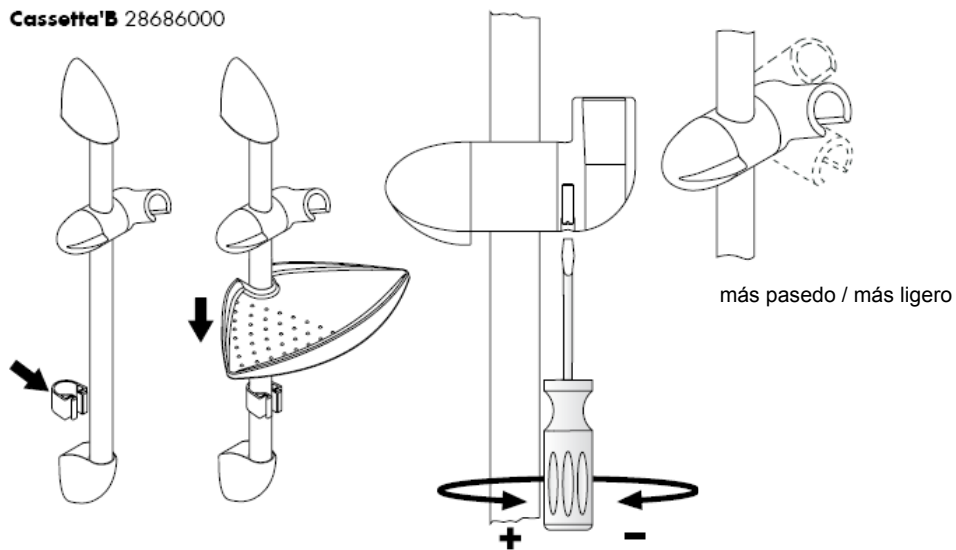

## Limpiar

Rubit®, la función de limpieza manual, permite quitar la cal simplemente frotando los ejectores.



## Entretimiento

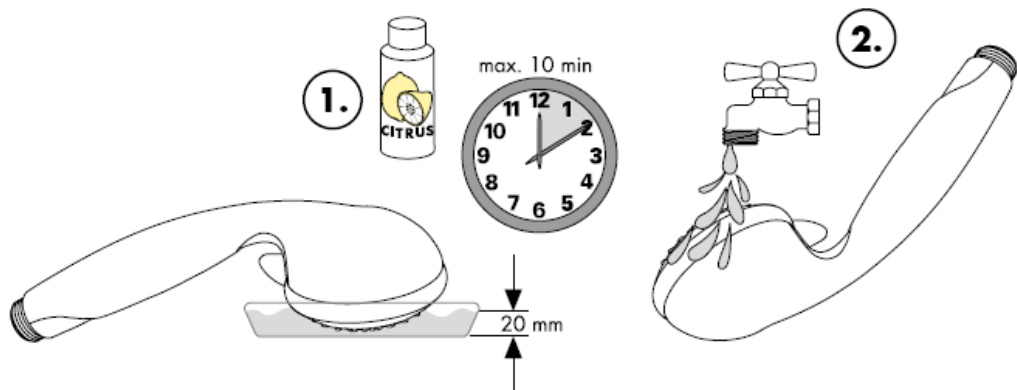

**hansgrohe**

# Handleiding

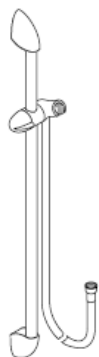

**Unica'B**  
27700XXX



**Unica'B**  
27705XXX

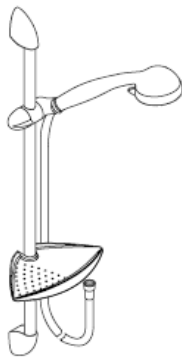

**Selecta/Unica'B**  
27780000/  
27781000



**Selecta 2jet/Unica'B**  
27786000

**hansgrohe**



Optimal functioneren gegarandeerd bij combinatie met Hansgrohe handdouche en doucheslang. De doucheslangen zijn alleen geschikt voor de aansluiting van douches aan kranen. Een versperring ná de doucheslang in de stroomrichting is niet toelaatbaar.

**Unica'B 27700XXX**

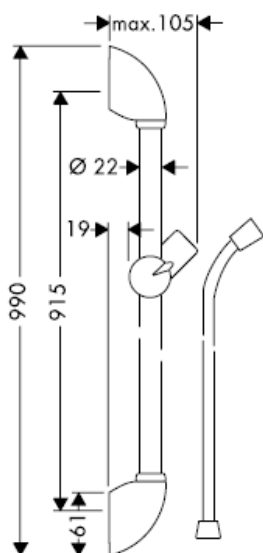

**Unica'B 27705XXX**

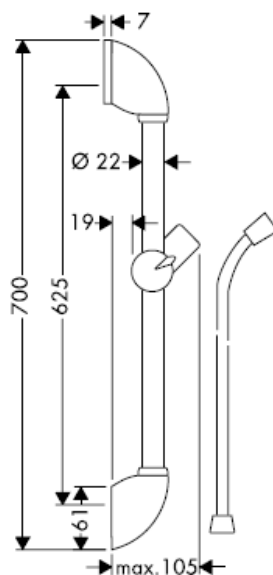

De douchestang 27824XXX is uitsluitend bestemd voor de export en niet in Duitsland verkrijgbaar!

**Selecta/Unica'B 27780000**

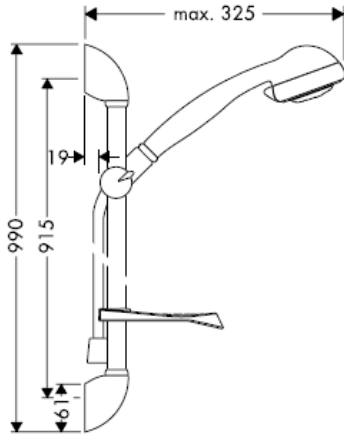

**Selecta/Unica'B 27781000**

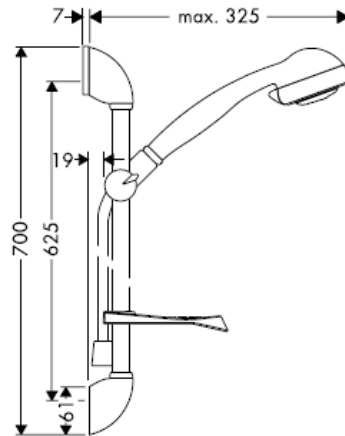

De douchestang 27824XXX is uitsluitend bestemd voor de export en niet in Duitsland verkrijgbaar!

**Selecta 2jet/Unica'B 27786000**

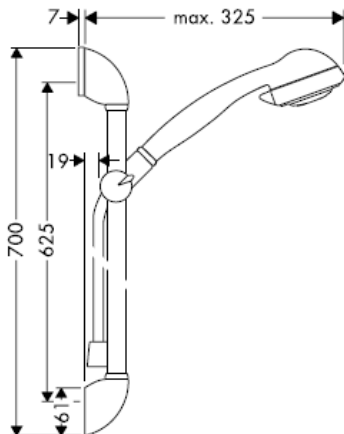

De douchestang 27824XXX is uitsluitend bestemd voor de export en niet in Duitsland verkrijgbaar!

## Selecta

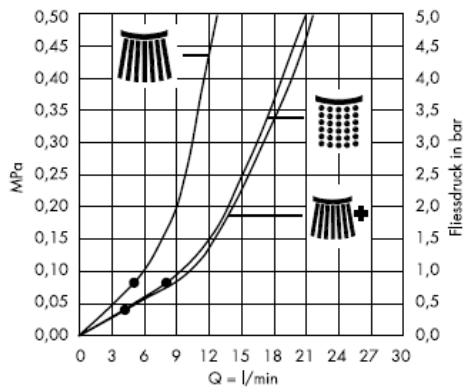

## Selecta 2jet

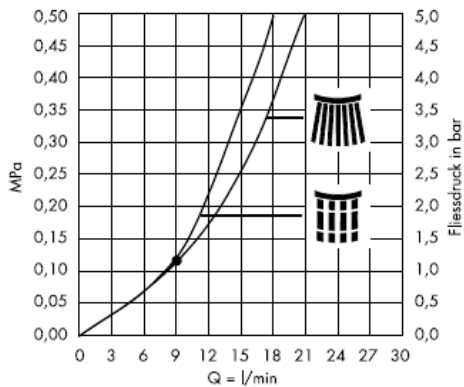

Vanaf • is het functioneren gegarandeerd.



Normale douchestraal



Normale douchestraal  
+ Doorstroombremer



Softstraal



Massagestraal

## Technische gegevens

Werkdruk: max. max. 0,6 MPa  
Aanbevolen werkdruk: 0,1 – 0,4 MPa  
(1 MPa = 10 bar = 147 PSI)  
Temperatuur warm water: max 60°C

Hansgrohe ééngreepsmengkranen kunnen samen met hydraulisch en thermisch gestuurde geisers gebruikt worden indien de uitstroomdruk min. 0,15 MPa bedraagt.

Bij de montage van het product door een vakkundige installateur moet men erop letten dat het bevestigingsoppervlak op één oppervlak zit (dus geen opliggende voegen of verspringende tegels), de wand geschikt is voor montage van producten en zeker geen zwakke plekken bevat.

De bijgevoegde schroeven en duvels zijn alleen geschikt voor beton. Bei andere wandsoorten dient u te letten op de voorschriften van de fabrikant van de schroeven en duvels.

## Keurmerk

	DVGW	P-IX	SVGW	ACS	NF	WRAS	KIWA
27700XXX							
27705XXX							
27780000							
27781000				X			
27786000				X			

Het bij de hoofddouche verpakte zeefje moet worden ingebouwd om vuil uit de waterleiding te weren. Vuil uit de leidingen kan de werking van de hoofddouche negatief beïnvloeden en/of de hoofddouche beschadigen. Voor deze schade is Hansgrohe niet verantwoordelijk.

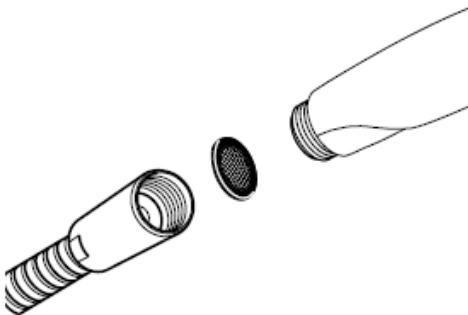

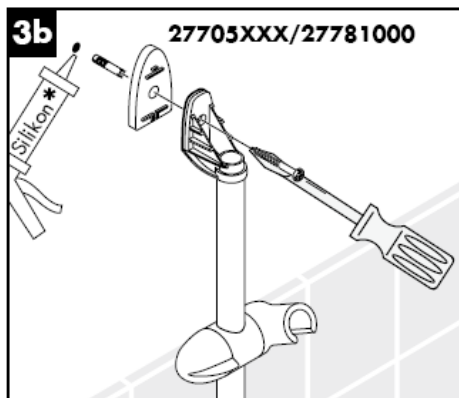
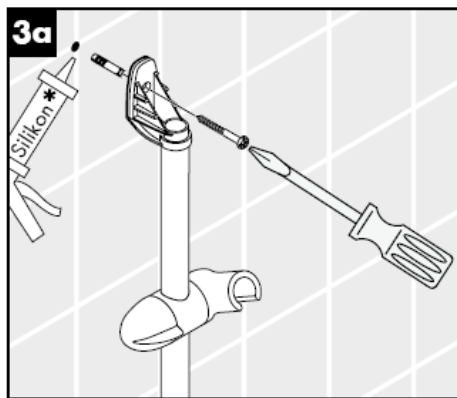
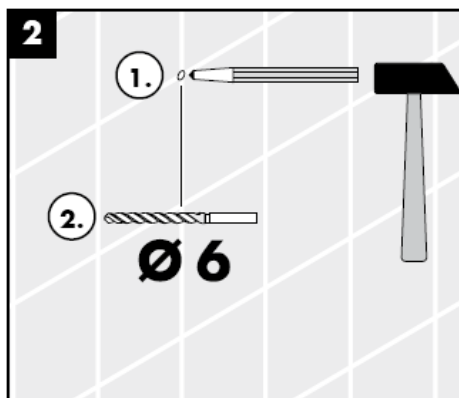
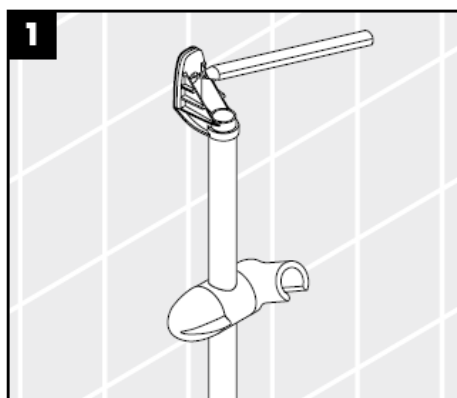

\* Silicone (azijnzuurvrij!)

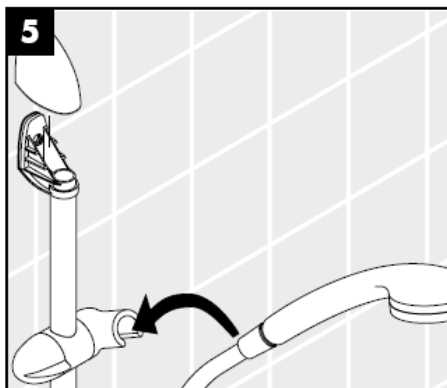
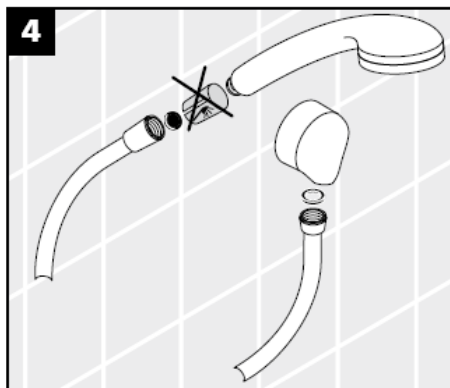

**Cassetta'B** 28686000

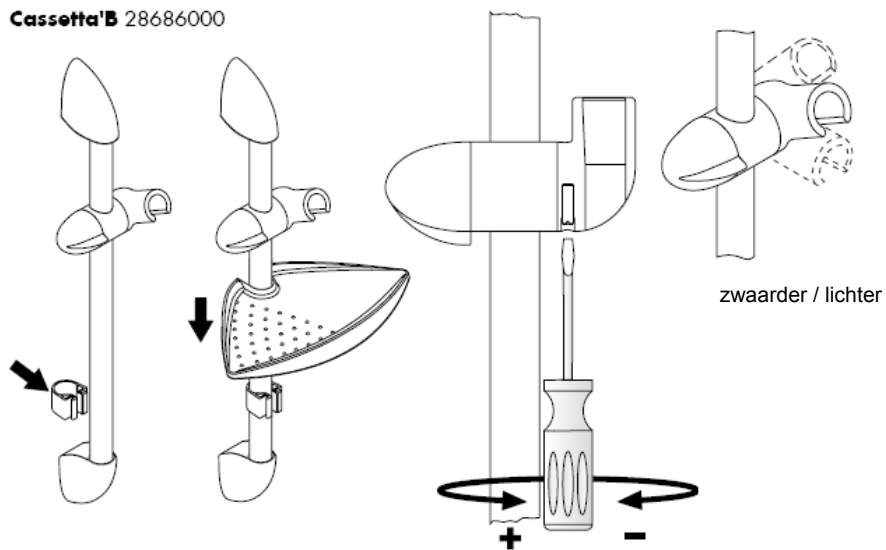

## Reinigen

Met Rubit®, de handmatige reinigingsfunctie, kunnen de straalopeningen door het met de hand gewrijven van kalk, gereinigd worden.

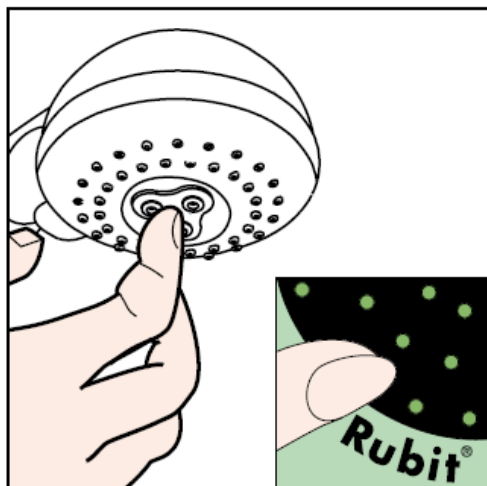

## Reinigingsaanwijzingen

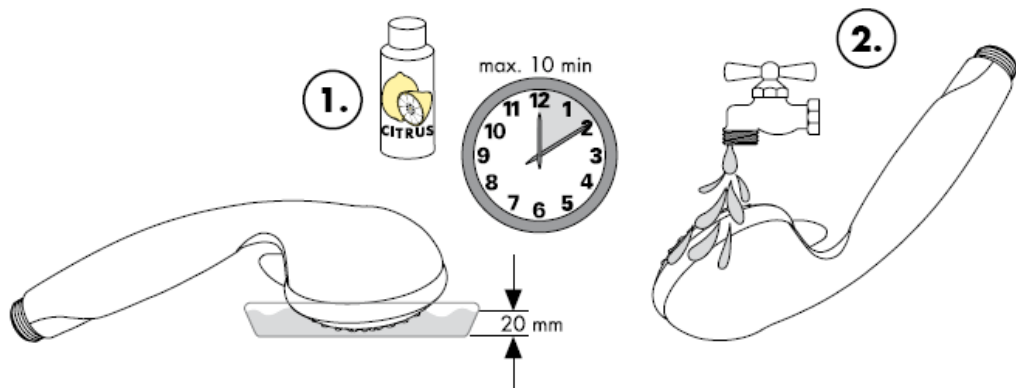

**hansgrohe**

# Monteringsvejledning



**Unica'B**  
27700XXX



**Unica'B**  
27705XXX

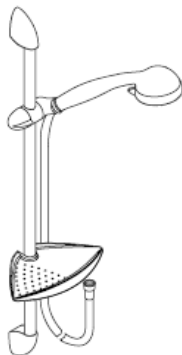

**Selecta/Unica'B**  
27780000/  
27781000



**Selecta 2jet/Unica'B**  
27786000

**hansgrohe**



Optimal funktion garanteres for anvendelse i forbindelse med Hansgrohe håndbrusere og Hansgrohe bruserslanger. Bruserslanger bør kun anvendes i forbindelse med tilslutning mellem brusere og armatur. Det er ikke tilladt at montere en afspærringsventil mellem bruser og slange!

**Unica'B 27700XXX**

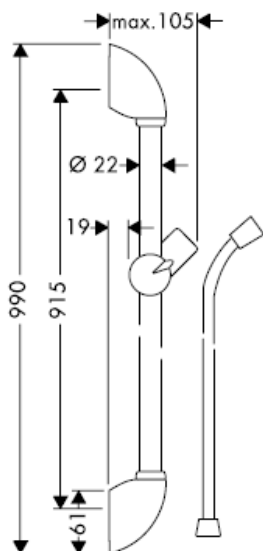

**Unica'B 27705XXX**

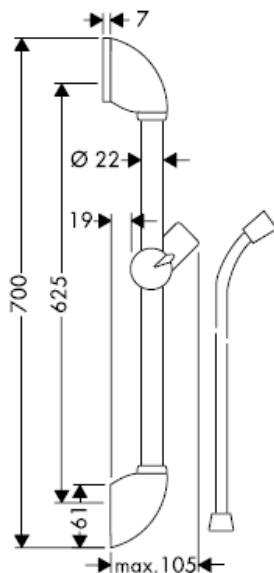

Bruserstang 27824XXX er udelukkende beregnet til eksport og kan derfor ikke fås i Tyskland!

**Selecta/Unica'B 27780000**

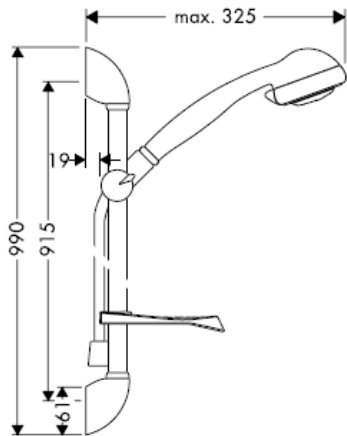

**Selecta/Unica'B 27781000**

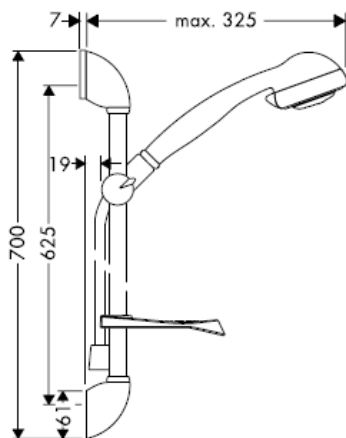

Bruserstang 27824XXX er udelukkende beregnet til eksport og kan derfor ikke fås i Tyskland!

**Selecta 2jet/Unica'B 27786000**

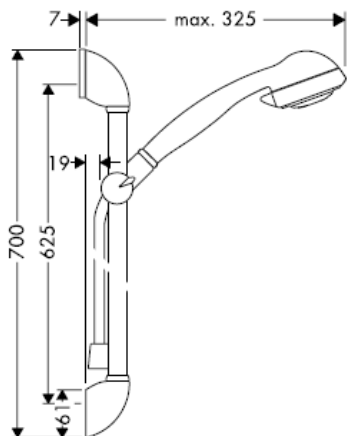

Bruserstang 27824XXX er udelukkende beregnet til eksport og kan derfor ikke fås i Tyskland!

## Selecta

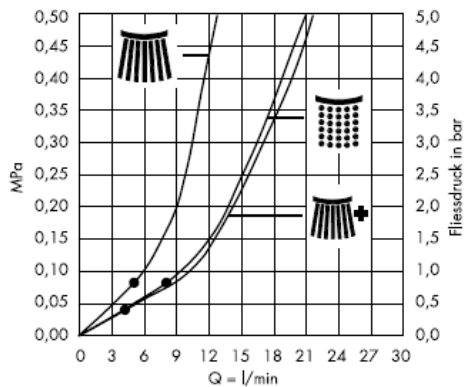

## Selecta 2jet

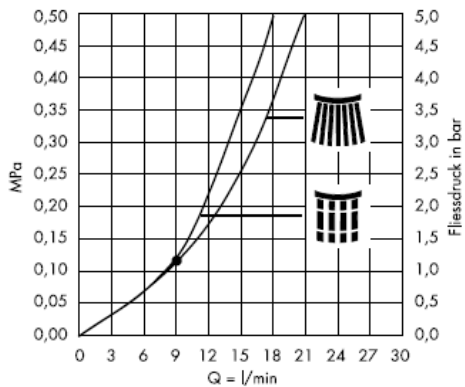

Fra • er funktionen anvendelig.



Normalstråle



Normalstråle +  
Gjenomstrømningsbe-  
grenser



Softstråle



Massagebrus

## Tekniske data

Driftstryk:	max. 0,6 MPa
Anbefalet driftstryk: (1 MPa = 10 bar = 147 PSI)	0,1 – 0,4 MPa
Varmtvandstemperatur:	max 60°C

Hansgrohe etgrebsarmaturer kan anvendes i forbindelse med hydraulisk- og termiskstyrede gennemstrømningsvandvarmere ved et vandtryk på 0,15 MPa.

## Godkendelse

	DVGW	P-IX	SVGW	ACS	NF	WRAS	KIWA
27700XXX							
27705XXX							
27780000							
27781000				X			
27786000				X			

Ved montering er det vigtigt at sikre sig, at hele befæstigelsesfladen er plan (ingen ujævne fuger eller fliser), samt at væggen er egnet til montering af produktet og specielt, at væggen ikke har nogen svage punkter. De medfølgende skruer og dübler er kun egnet til beton. Ved anden vægopbygning bør producenten af dübler kontaktes for nærmere information.

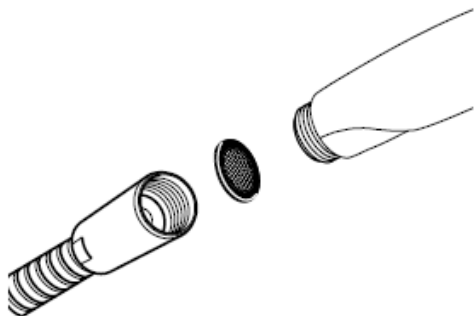

Den vedlagte smudsfangssi skal indsættes i bruseren for at undgå snavs fra rørsystemet. Indskyllet snavs kan have indflydelse på bruserens funktion og/eller føre til beskadigelser på håndbruserens funktionsdele.

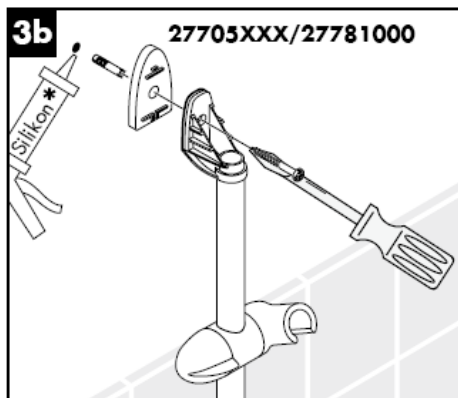
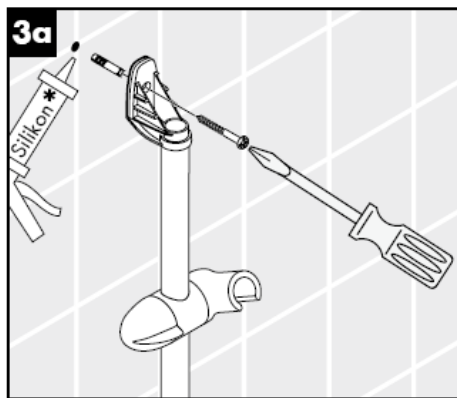
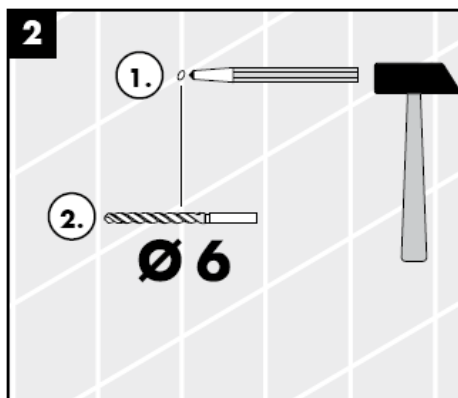
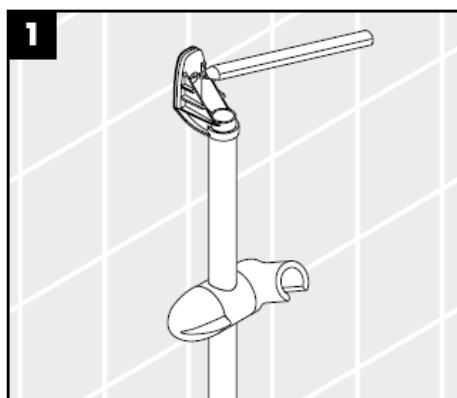

\* Silikone (eddikesyre-fri)

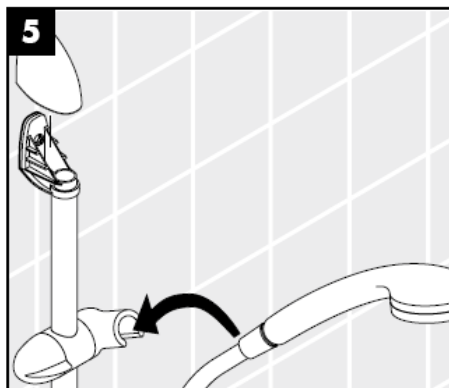
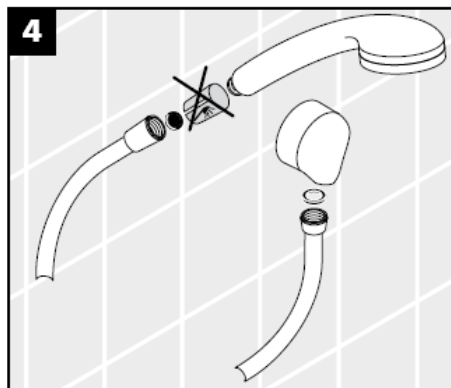

**Cassetta'B** 28686000

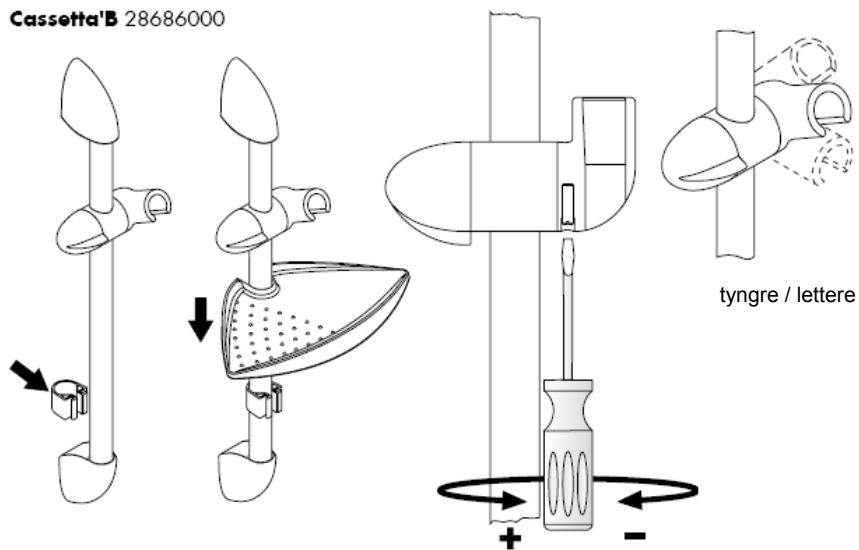

## Rengøring

Med Rubit®, den manuelle rengøringsfunktion kan strålekanalerne let renses for kalk - der skal blot gnubbes!



## Rengøring

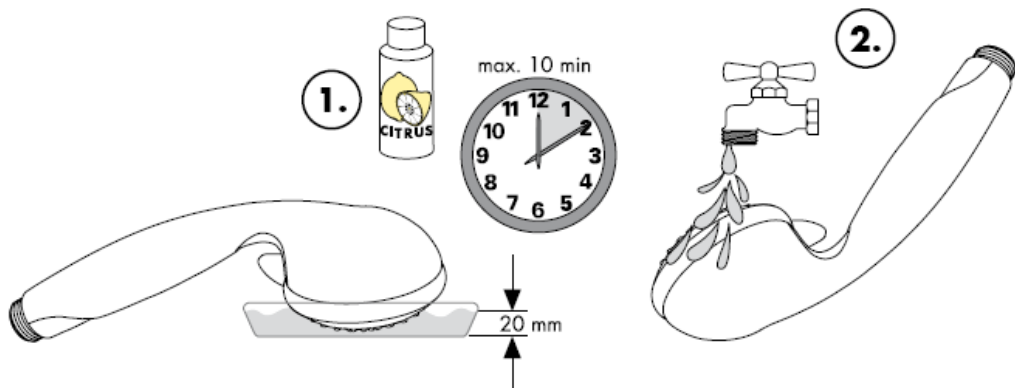

**hansgrohe**

# Manual de Instalación



**Unica'B**  
27700XXX



**Unica'B**  
27705XXX

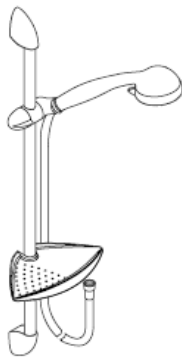

**Selecta/Unica'B**  
27780000/  
27781000



**Selecta 2jet/Unica'B**  
27786000

**hansgrohe**



O bom funcionamento é apenas garantido em combinação com chuveiros de mão e tubos flexíveis Hansgrohe. Os tubos flexíveis são apenas adequados para uma ligação do chuveiro à misturadora. Nunca instale uma válvula de corte entre a misturadora e o tubo flexível.

**Unica'B 27700XXX**

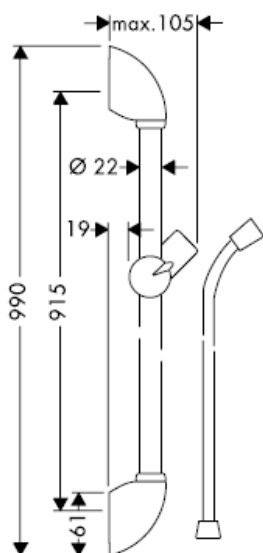

**Unica'B 27705XXX**

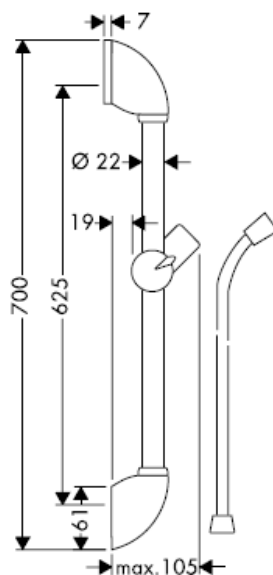

A barra do chuveiro 27824XXX destina-se, única e exclusivamente, à exportação e não está disponível para o mercado alemão!

**Selecta/Unica'B 27780000**

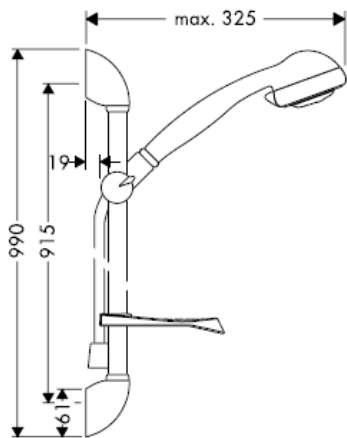

**Selecta/Unica'B 27781000**

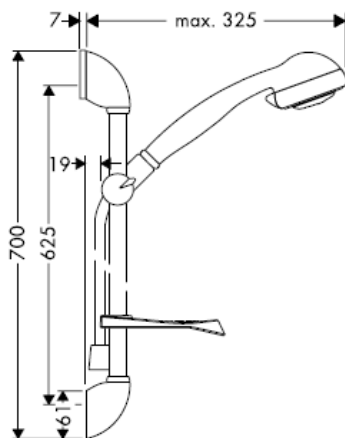

A barra do chuveiro 27824XXX destina-se, única e exclusivamente, à exportação e não está disponível

**Selecta 2jet/Unica'B 27786000**

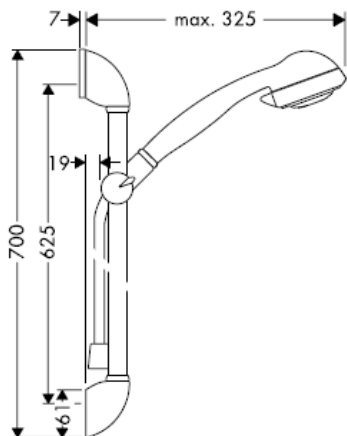

A barra do chuveiro 27824XXX destina-se, única e exclusivamente, à exportação e não está disponível

## Selecta

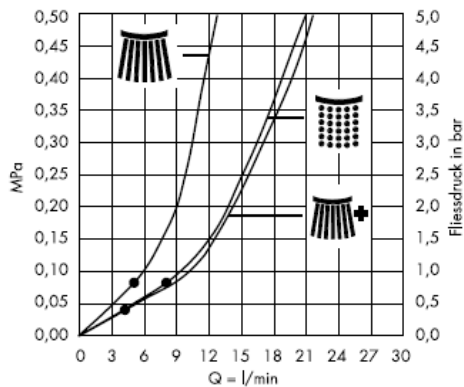

## Selecta 2jet

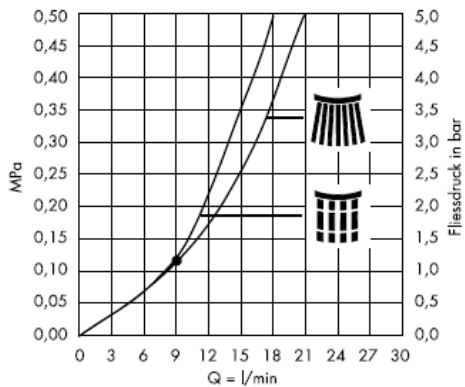

- A partir deste ponto inicia-se o funcionamento correcto.



operação normal



operação normal +  
Waterdimmer®  
(limitador de caudal)



operação soft



operação massagem

## Dados Técnicos

Pressão de funcionamento: max. 0,6 MPa  
Pressão de func. recomendada: 0,1 – 0,4 MPa  
(1 MPa = 10 bar = 147 PSI)  
Temperatura da água quente: max 60°C

As misturadoras monocomando Hansgrohe podem ser utilizadas com esquentadores (de controlo térmico ou hidráulico) desde que a pressão de utilização seja, no mínimo, de 0,15 MPa.

Durante a montagem do produto por técnicos qualificados, deve ter-se em atenção que a superfície de fixação seja plana em toda a área da fixação (sem juntas sobrepostas/salientes ou ladrilhos deslocados), que o dispositivo de montagem na parede seja adequado para uma montagem na parede e que este não apresente nenhuns pontos fracos. Os parafusos e buchas incluídos no volume de fornecimento são apenas adequados para betão. Para outros métodos de montagem na parede devem ser respeitadas as indicações do fabricante das buchas.

## Marca de controlo

	DVGW	P-IX	SVGW	ACS	NF	WRAS	KIWA
27700XXX							
27705XXX							
27780000							
27781000				X			
27786000				X			

O filtro de rede deve ser colocado para proteger o chuveiro de areias e resíduos provenientes da tubagem. Resíduos e areias podem danificar componentes, ou provocar mau funcionamento do chuveiro; as avarias assim provocadas anulam a nossa responsabilidade e anulam a nossa garantia.

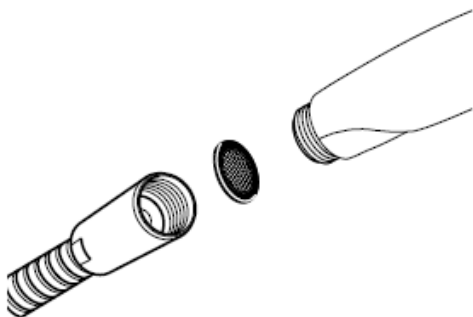

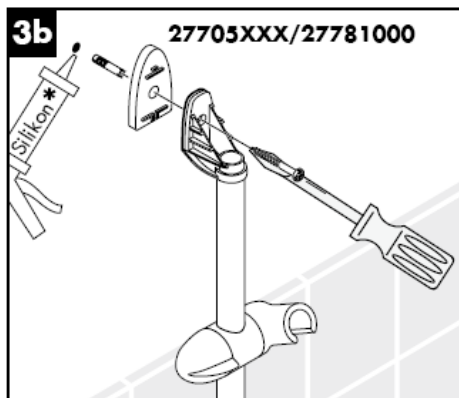
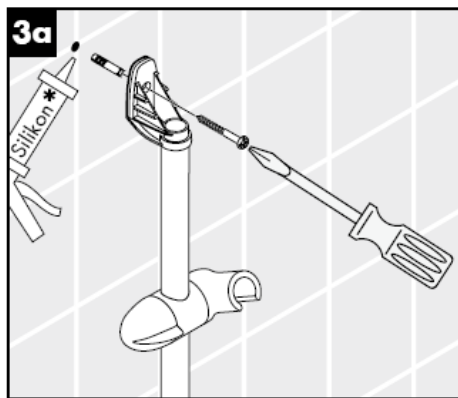
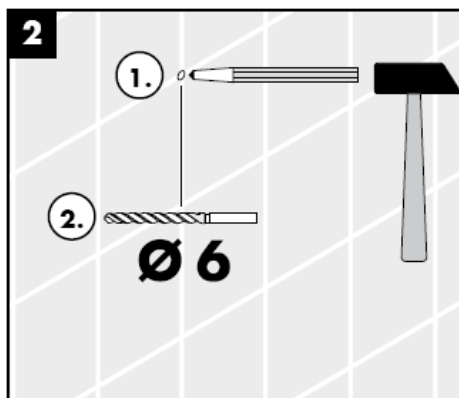
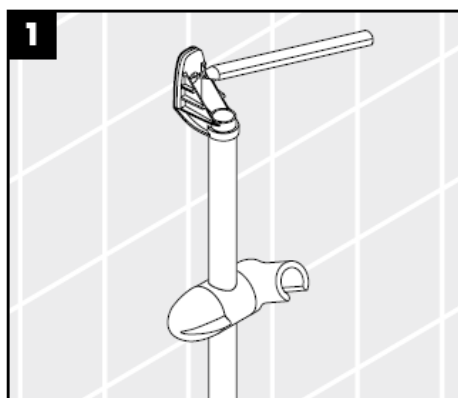

\* Silicone (sem ácido acético)

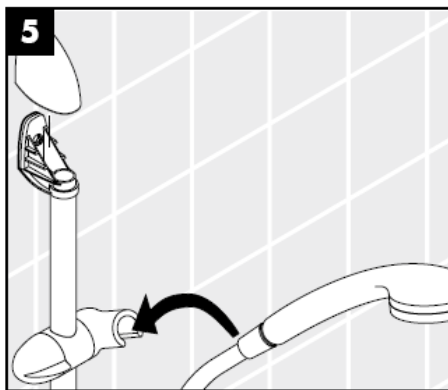
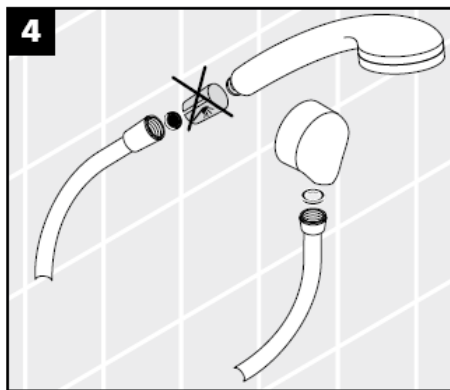

**Cassetta'B** 28686000

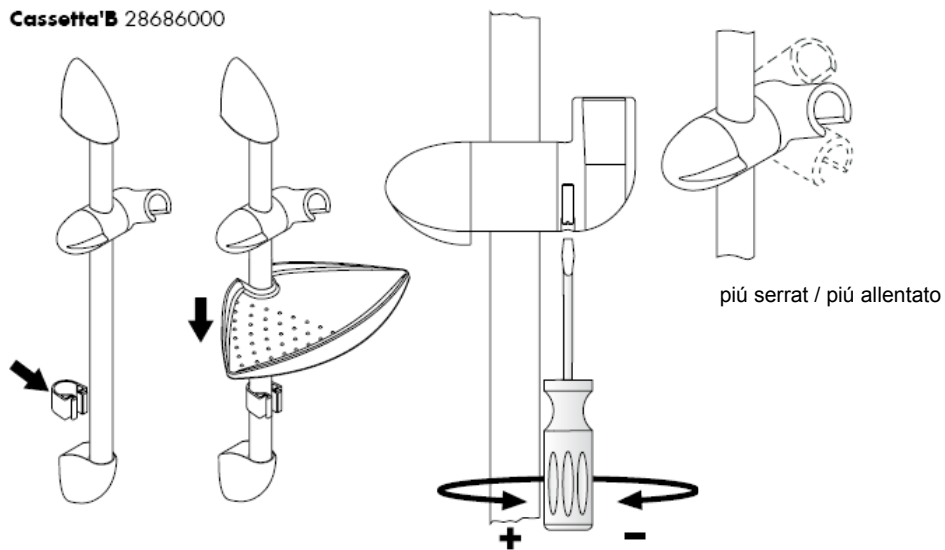

## Limpeza

O sistema de limpeza Rubit® requer apenas uma ligeira passagem com a mão para remover os depósitos de calcário do emulsor.

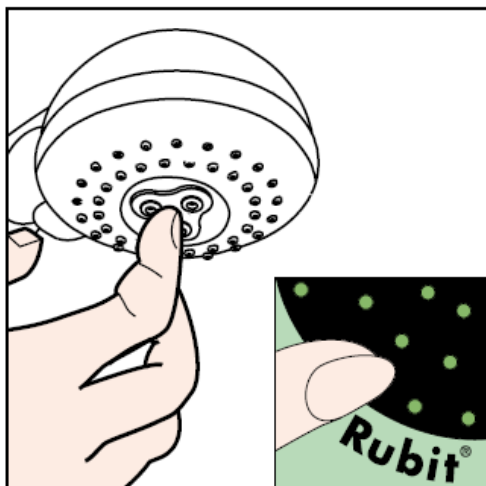

### Instruções de Limpeza

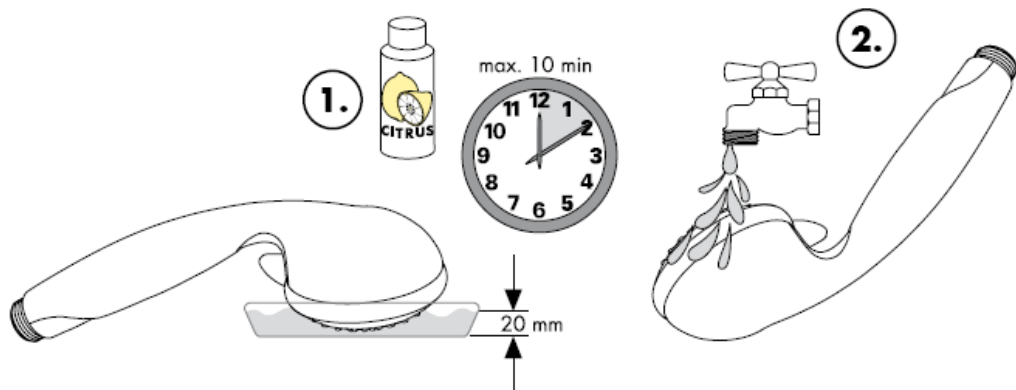

**hansgrohe**

# Instrukcja montażu

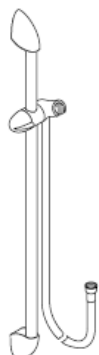

**Unica'B**  
27700XXX



**Unica'B**  
27705XXX

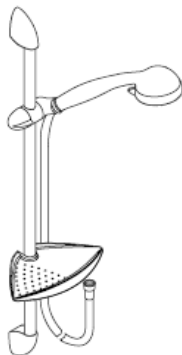

**Selecta/Unica'B**  
27780000/  
27781000



**Selecta 2jet/Unica'B**  
27786000

**hansgrohe**



Optymalne działanie gwarantuje się tylko w odniesieniu do pryszniców ręcznych i węży prysznicowych Hansgrohe. Węże prysznicowe przeznaczone są do podłączenia tylko z armaturą. Blokada za wężem w kierunku przepływu jest niedopuszczalna.

**Unica'B 27700XXX**

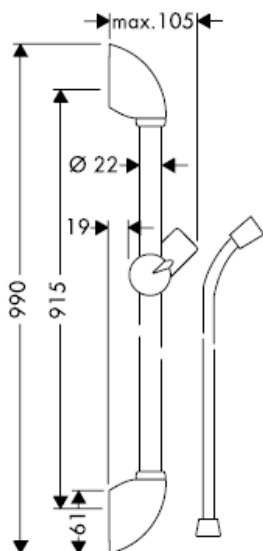

**Unica'B 27705XXX**

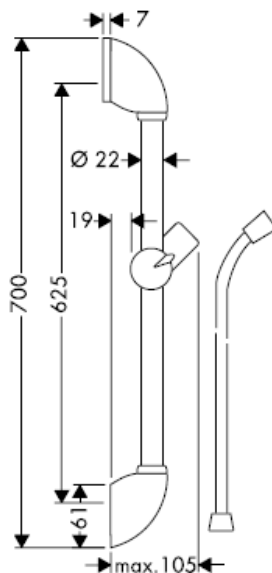

Drażek prysznica 27824XXX przeznaczony jest wyłącznie na eksport i dlatego w Niemczech jest niedostępny!

**Selecta/Unica'B 27780000**

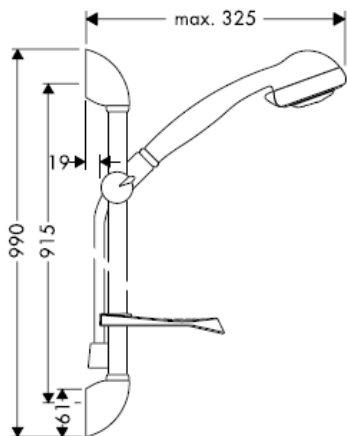

**Selecta/Unica'B 27781000**

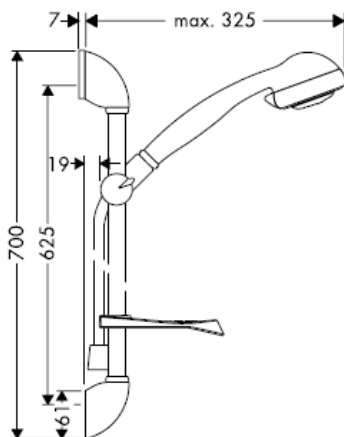

Drażek prysznica 27824XXX przeznaczony jest wyłącznie na eksport i dlatego w Niemczech jest

**Selecta 2jet/Unica'B 27786000**

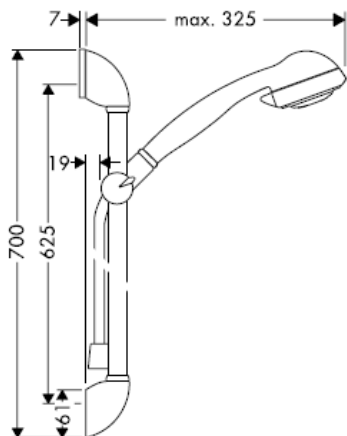

Drażek prysznica 27824XXX przeznaczony jest wyłącznie na eksport i dlatego w Niemczech jest

## Selecta

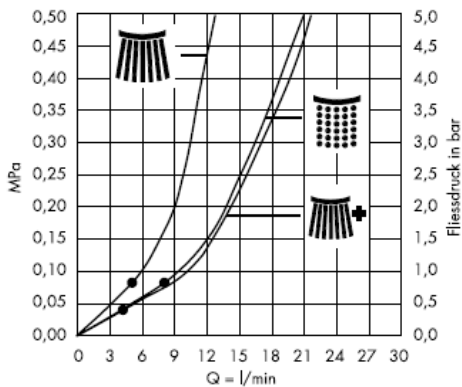

## Selecta 2jet

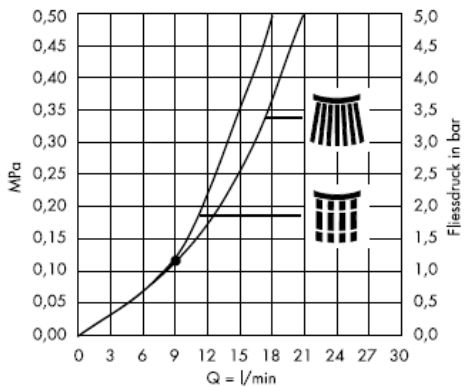

Od • możliwe jest funkcjonowanie.



Strumień normalny



Strumień normalny +  
Waterdimmer®  
(ogranicznik  
przepływu)



Strumień miękki



Strumień masujący

## Dane techniczne

Ciśnienie robocze:	max. 0,6 MPa
Zalecane ciśnienie robocze: (1 MPa = 10 bary = 147 PSI)	0,1 – 0,4 MPa
Temperatura wody gorącej:	max 60°C

Mieszacze jednouchwytowe Hansgrohe mogą być stosowane w połączeniu z przepływowymi podgrzewaczami wody, sterowanymi hydraulicznie i termicznie, gdy ciśnienie wody wynosi co najmniej 0,15 MPa.

Przy montażu produktu przez wykwalifikowany personel fachowy należy zważyć na to, by powierzchnia mocowania na całym obszarze mocowania była równa (by nie było szczelin wzgl. wzajemnie przesuniętych płytek), rodzaj ściany nadawał się do montażu produktu i zwłaszcza, by nie było żadnych słabych stron. Umieszczone w dostawie śruby i kołki rozporowe są przeznaczone tylko do betonu. Przy innych rodzajach montażu ścianowego należy przestrzegać danych producenta kołków rozporowych.

## Znak jakości

DVGW	P-IX	SVGW	ACS	NF	WRAS	KIWA
27700XXX						
27705XXX						
27780000						
27781000			X			
27786000			X			

Znajdujące się przy prysznicu sitko musi zostać zainstalowane, aby zatrzymać zanieczyszczenia z instalacji. Przedostające się zanieczyszczenia mogą mieć ujemny wpływ na działanie i/lub prowadzić do usterek w działaniu elementów prysznica. Za powstałe z tego tytułu szkody firma Hansgrohe nie ponosi odpowiedzialności.

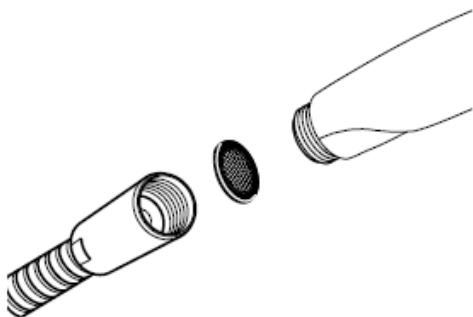

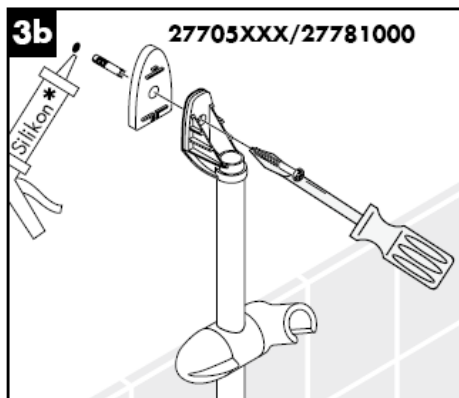
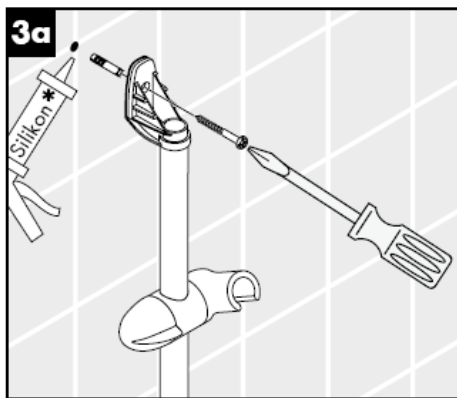
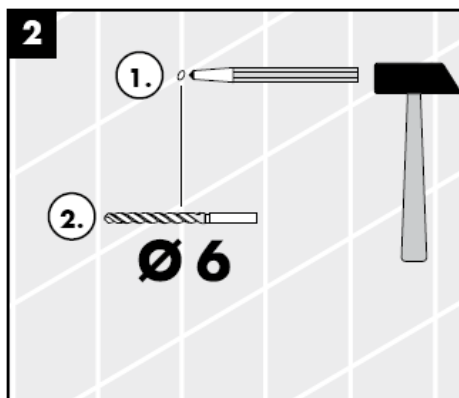
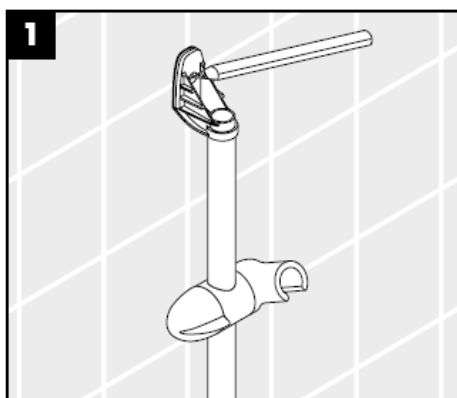

\* Silikon (neutralny)

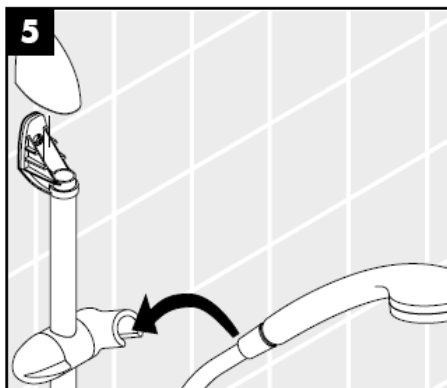
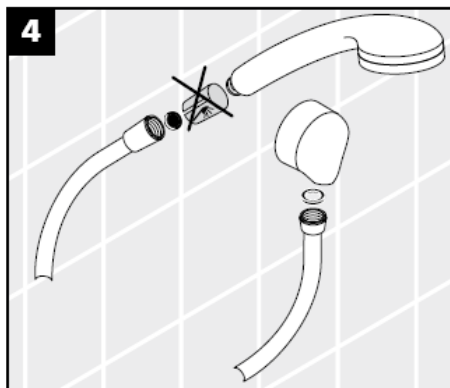

**Cassetta'B** 28686000

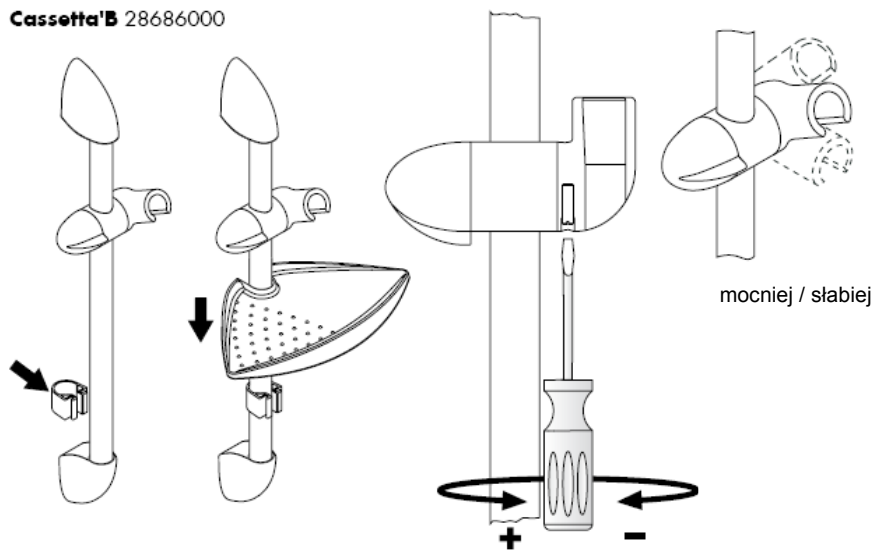

## Czyszczenie

Funkcja Rubit® wymaga jedynie delikatnego potarcia dłonią, aby usunąć ewentualne osady kamienia wapiennego.



## Instrukcja pielęgnacji

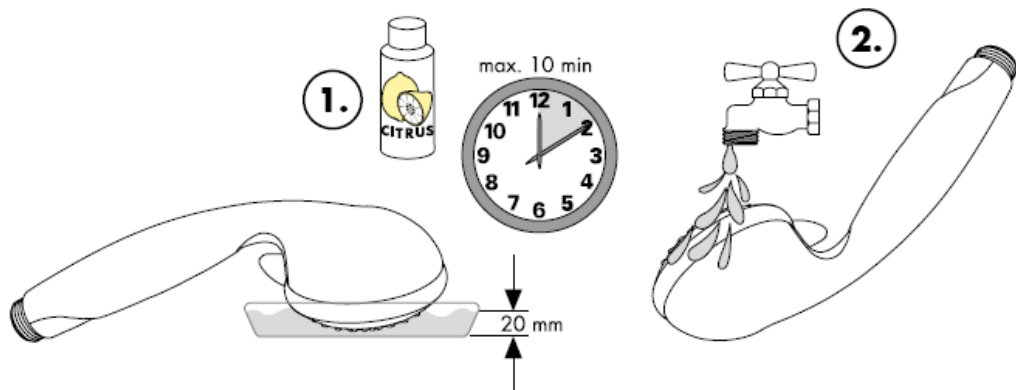

**hansgrohe**

# Montážní návod



**Unica'B**  
27700XXX



**Unica'B**  
27705XXX

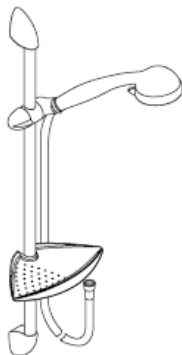

**Selecta/Unica'B**  
27780000/  
27781000



**Selecta 2jet/Unica'B**  
27786000

**hansgrohe**



Optimální funkce je zaručena pouze s ručními sprchami a sprchovými hadicemi Hansgrohe. Sprchové hadice jsou vhodné pouze pro napojení sprch na armatury. Řazení uzavíracího ventilu za hadici po směru toku je nepřípustné!

**Unica'B 27700XXX**

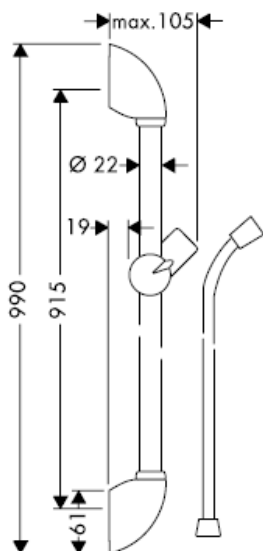

**Unica'B 27705XXX**

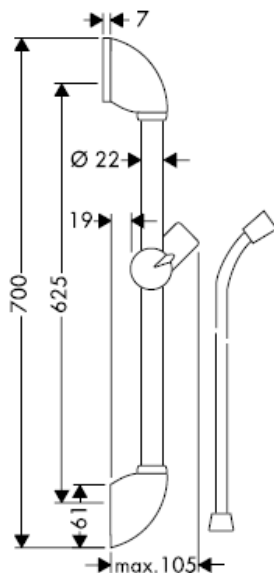

Tyč sprchy 27824XXX je určená výhradně pro export a není ji možno v Německu obdržet!

**Selecta/Unica'B 27780000**

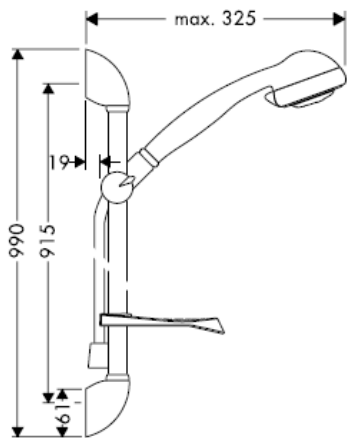

**Selecta/Unica'B 27781000**

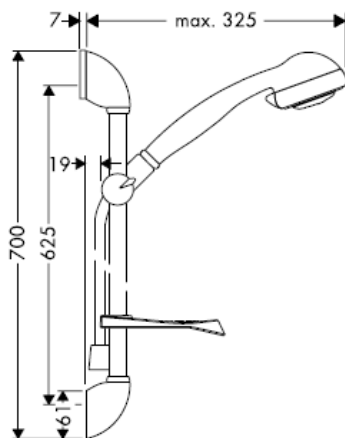

Tyč sprchy 27824XXX je určená výhradně pro export a není ji možno v Německu obdržet!

**Selecta 2jet/Unica'B 27786000**

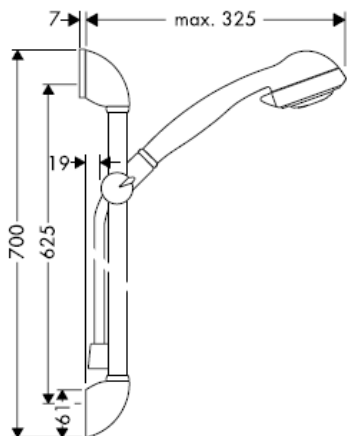

Tyč sprchy 27824XXX je určená výhradně pro export a není ji možno v Německu obdržet!

## Selecta

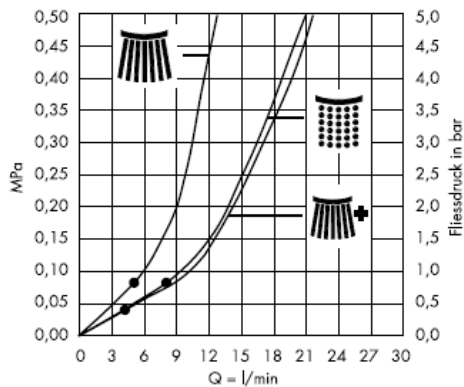

## Selecta 2jet

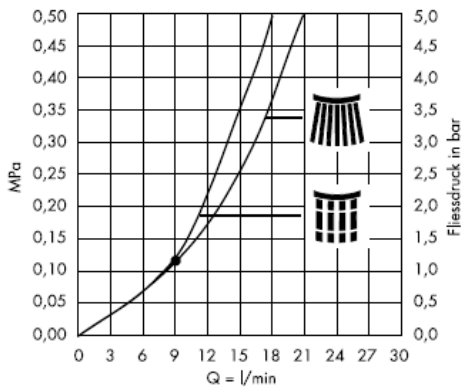

Od • je zaručená funkce



Normální proud



Normální proud +  
Waterdimmer®  
(omezovaèe průtoku)



Jemný proud



masážní proud

## Technické údaje

Provozní tlak:	max. 0,6 MPa
Doporučený provozní tlak: (1 MPa = 10 barů = 147 PSI)	0,1 – 0,4 MPa
Teplota horké vody:	max 60°C

Pákové baterie Hansgrohe mohou být používány ve spojení s hydraulicky nebo tepelně řízenými průtokovými ohříváči, pokud tlak při průtoku je alespoň 0,15 MPa.

Při montáži produktu kvalifikovaným odborným personálem je třeba dbát na to, aby upevňovací plochy byly v celém rozsahu upevnění rovné (žádné vyčnívající spáry nebo navzájem přesazené obklady), aby konstrukce stěny byla pro montáž produktu vhodná a zvláště aby v ní nebyla žádná slabá místa. Příložené vruty a hmoždinky jsou vhodné pouze pro beton. Při jiných konstrukčních materiálech stěny je třeba se řídit údaji výrobce hmoždinek.

## zkušební značka

	DVGW	P-IX	SVGW	ACS	NF	WRAS	KIWA
27700XXX							
27705XXX							
27780000							
27781000				X			
27786000				X			

Do přívodu musí být zabudováno se sprchou dodávané sítko, aby zachycovalo nečistoty vyplavené z vodovodní sítě. Vyplavené nečistoty mohou ovlivnit funkci sprchy a nebo mohou vést i k jejímu poškození. Na takto vzniklé škody se nevztahuje záruka firmy Hansgrohe.

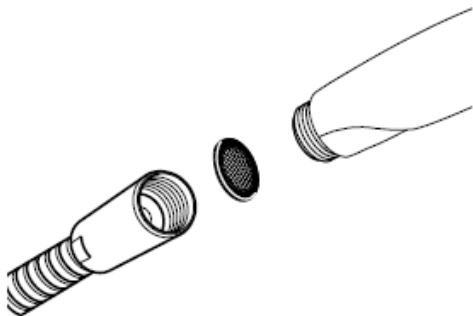

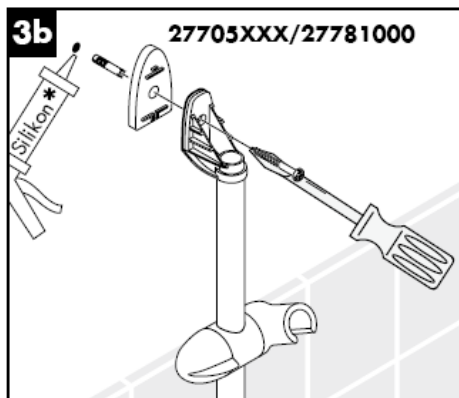
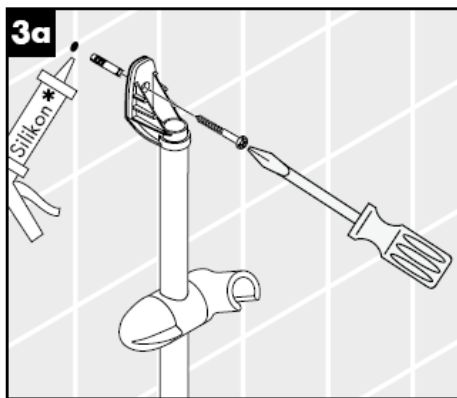
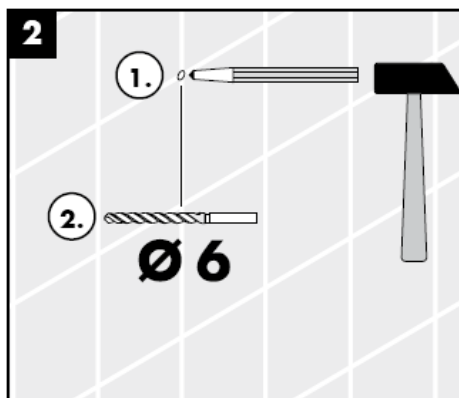
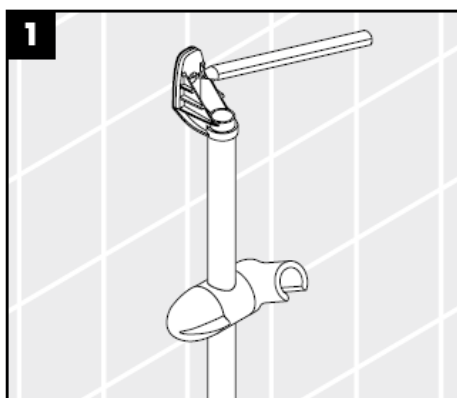

\* Silikon (bez kyseliny octové!)

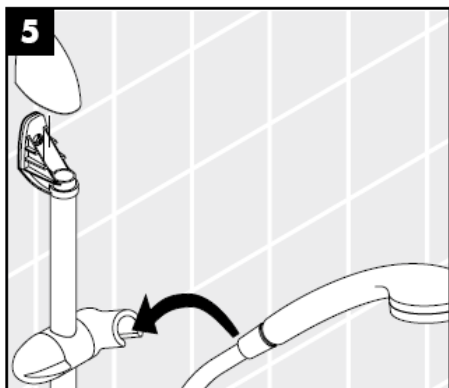
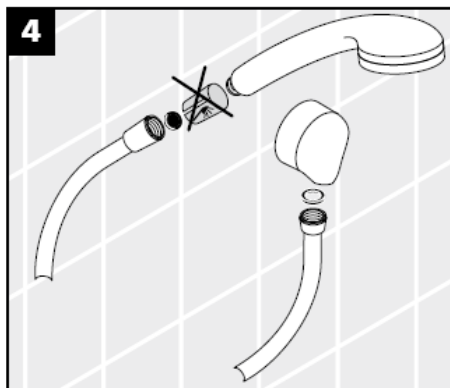

**Cassetta'B** 28686000

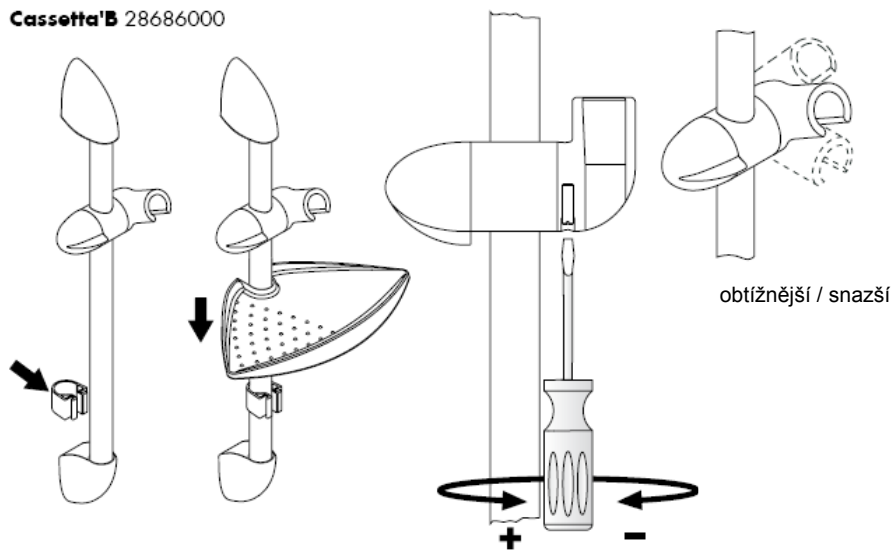

## Čištění

S ruční čistící funkcí Rubit® stačí jednoduché odstranění vodního kamene prsty z trysek kotouče tvarujícího proud vody.



### Návod na čištění

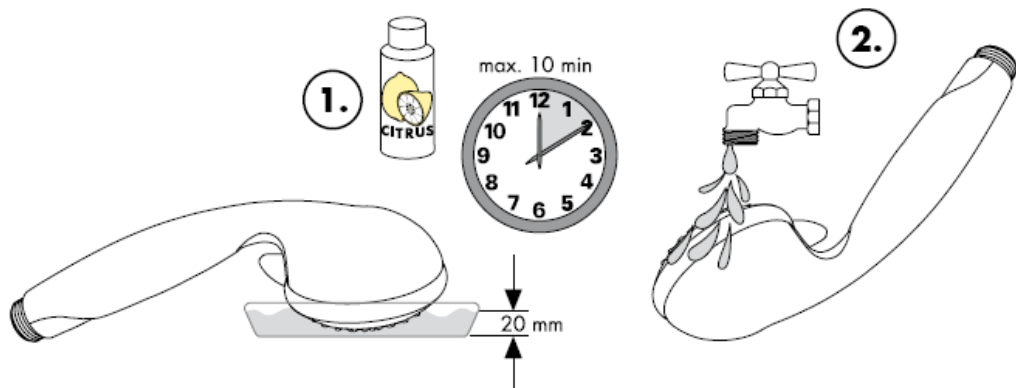

**hansgrohe**

# Montážny návod



**Unica'B**  
27700XXX



**Unica'B**  
27705XXX

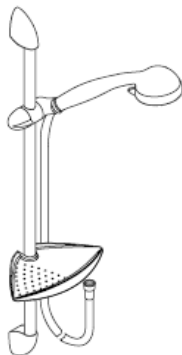

**Selecta/Unica'B**  
27780000/  
27781000



**Selecta 2jet/Unica'B**  
27786000

**hansgrohe**



Optimálna funkcia je zaručen iba s ručnými sprchami a sprchovými hadicami Hansgrohe. Sprchové hadice sú vhodné iba pre napojenie sprch na batérie. Umiestnenie uzatváracieho ventilu za hadicou v smere toku je neprípustne.

**Unica'B 27700XXX**

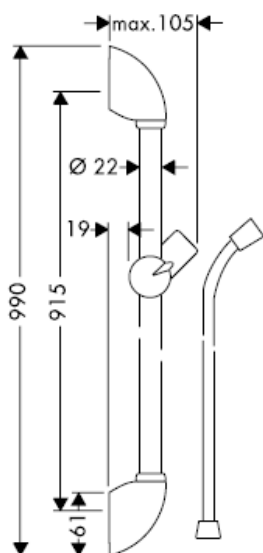

**Unica'B 27705XXX**

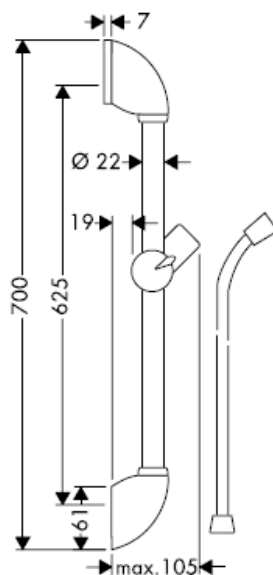

Zvukové odtienenie

**Selecta/Unica'B 27780000**

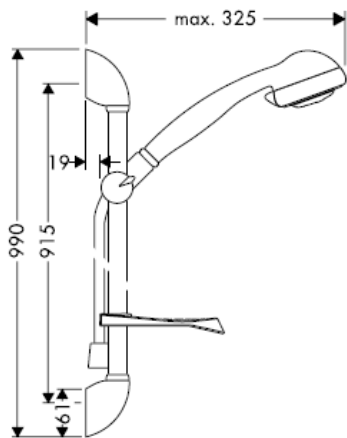

**Selecta/Unica'B 27781000**

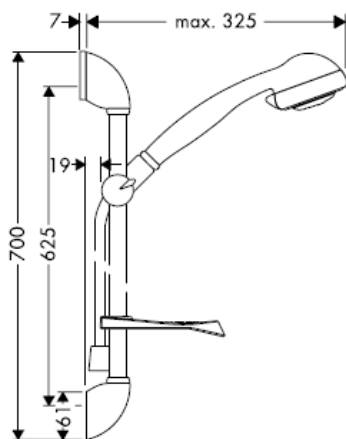

Zvukové odtienenie

**Selecta 2jet/Unica'B 27786000**

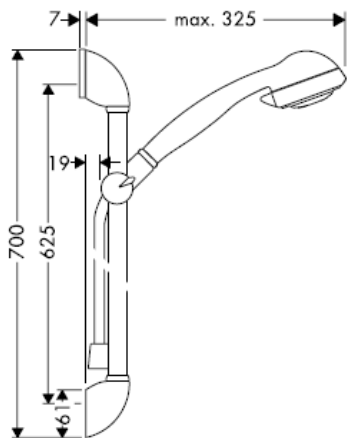

Zvukové odtienenie

## Selecta

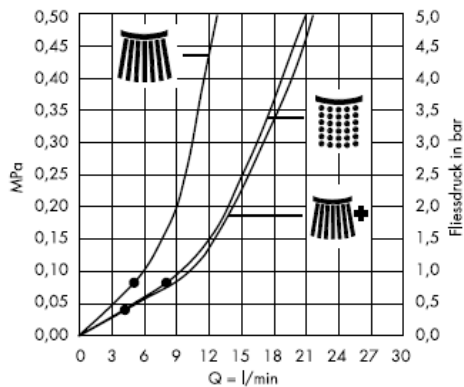

## Selecta 2jet

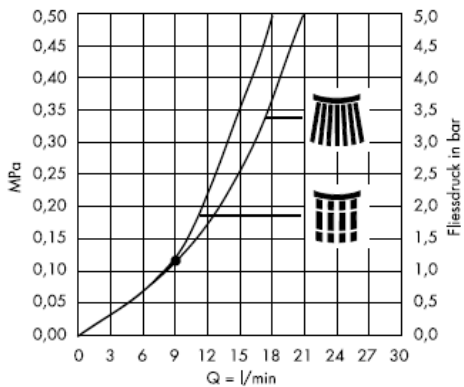

Od • je zaručená funkcia.



Normálny prúd



Normálny prúd +  
Waterdimmer®  
(obmedzenie prietoku)



Mierny prúd



masážny prúd

## Technické údaje

Prevádzkový tlak:	max. 0,6 MPa
Doporučený prevádzkový tlak: (1 MPa = 10 barov = 147 PSI)	0,1 – 0,4 MPa
Teplota teplej vody:	max 60°C

Pákové batérie firmy Hansgrohe môžu byť používané v spojení s hydraulicky a tepelne riadenými prietokovými ohrievačmi, pokiaľ je tlak prúdu aspoň 0,15 MPa.

Pri montáži produktu kvalifikovaným odborným personálom je nutné dbať na to, aby upevňovacie plochy boli v celom rozsahu upevnenia rovné (žiadne vyčnievajúce škáry alebo navzájom predsadené obklady), aby konštrukcia steny bola pre montáž produktu vhodná a zvlášť aby v nej neboli žiadne slabé miesta. Priložené vruty a hmoždinky sú vhodné len pre betón. Pri iných konštrukčných materiáloch steny je nutné riadiť sa údajmi výrobcu hmoždiniek.

## Osvedčenie o skúške

	DVGW	P-IX	SVGW	ACS	NF	WRAS	KIWA
27700XXX							
27705XXX							
27780000							
27781000				X			
27786000				X			

Do prívodu musí byť zabudované so sprchou dodávané sítko, aby zachytilo nečistoty vyplavené z vodovodnej siete. Vyplavené nečistoty môžu ovplyvniť funkciu sprchy, alebo spôsobiť jej poškodenie. Na takto vzniknuté škody sa nevzťahuje záruka firmy Hansgrohe.

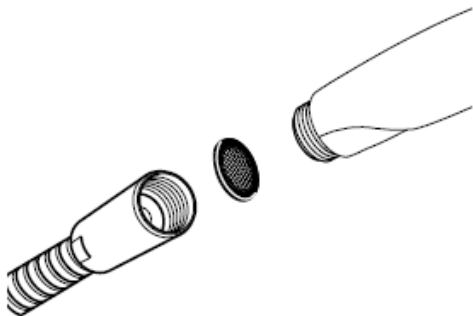

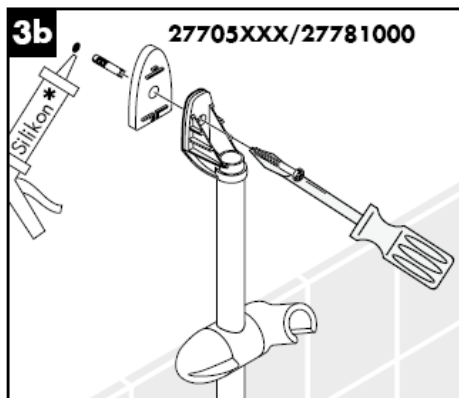
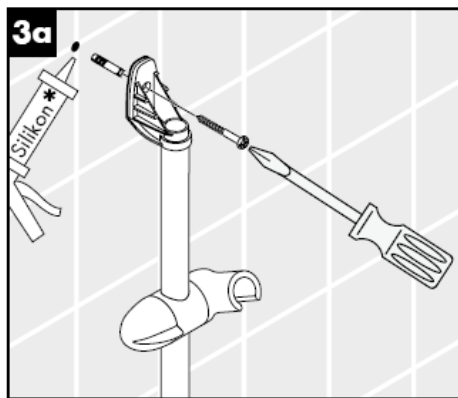
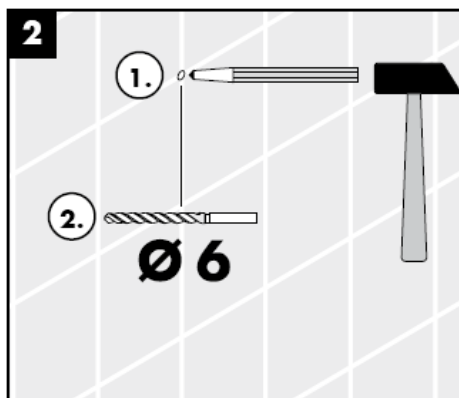
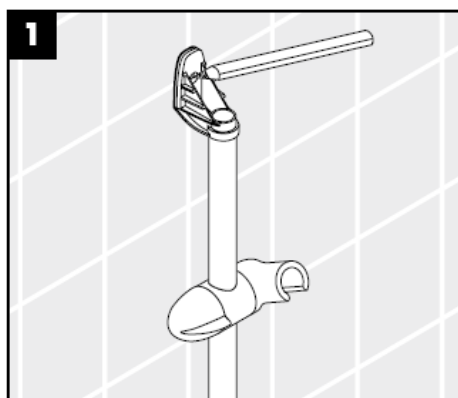

\* Silikon (bez kyseliny octovej!)

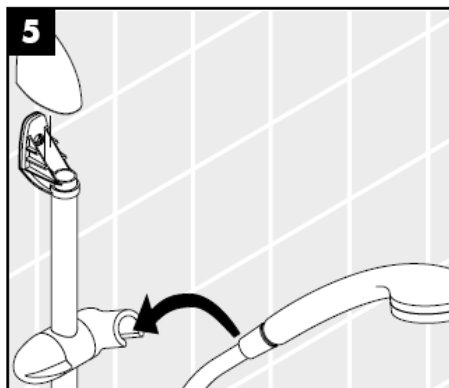
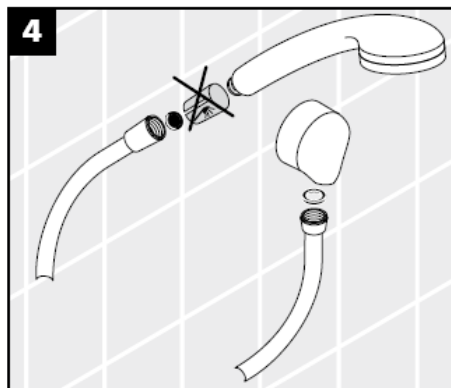

**Cassetta'B** 28686000

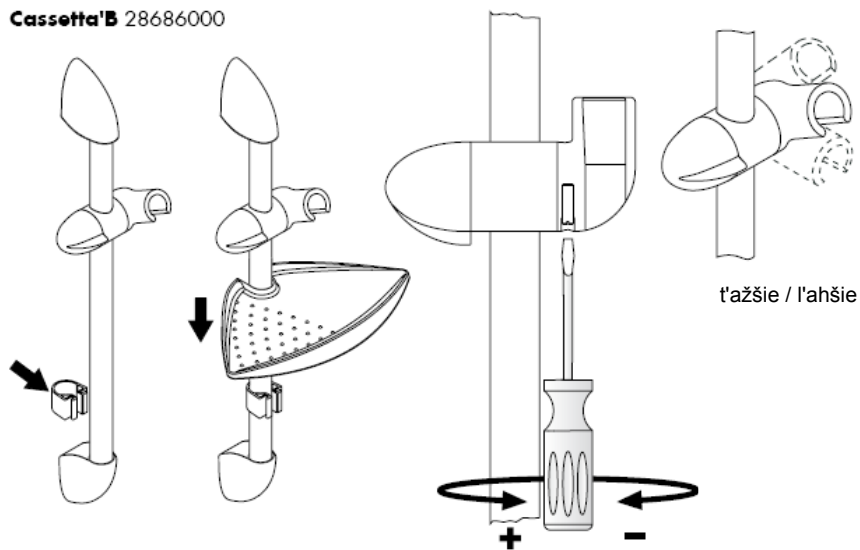

## Čištění

Čistiaca funkcia Rubit, stačí na jednoduché odstránenie vodného kameňa prstami z trysiek kotúča tvarujúceho prúd vody.



### Návod na čistenie

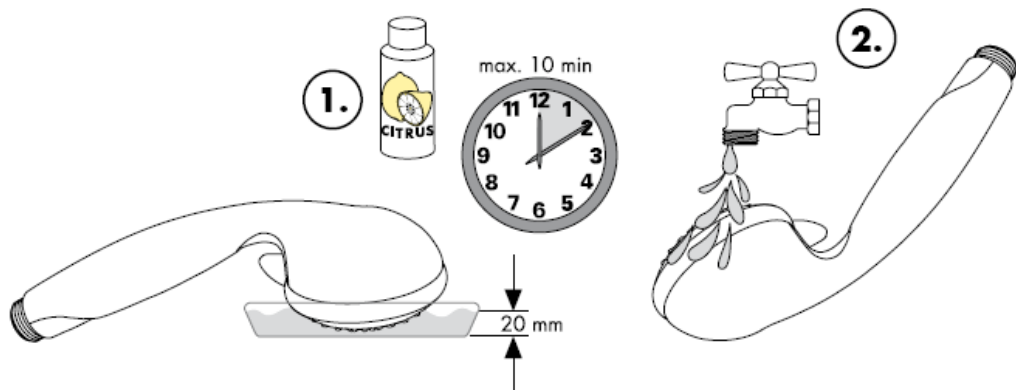

**hansgrohe**

Hansgrohe · Postfach 1145 · D-77761 Schiltach · Telefon +49 (0) 78 36/51-1282 · Telefax +49 (0) 7836/511440  
E-Mail: [info@hansgrohe.com](mailto:info@hansgrohe.com) · Internet: [www.hansgrohe.com](http://www.hansgrohe.com)

05/2007  
9.08.069.04  
Slovensky

# 组装说明

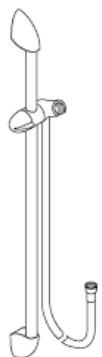

**Unica'B**  
27700XXX



**Unica'B**  
27705XXX

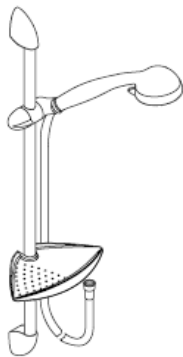

**Selecta/Unica'B**  
27780000/  
27781000



**Selecta 2jet/Unica'B**  
27786000

**hansgrohe**



只有与汉斯格雅手提花洒和汉斯格雅淋浴器软管组合使用，方担保最佳的功能。

淋浴软管只适合从淋浴器连接到管接头。切勿在管接头和软管之间安装截止装置。

**Unica'B 27700XXX**

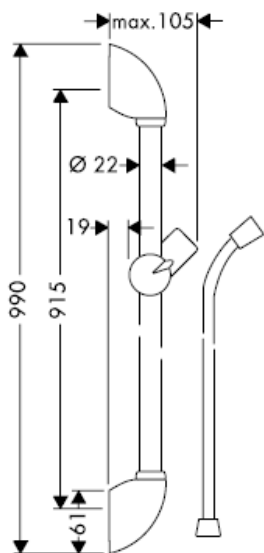

**Unica'B 27705XXX**

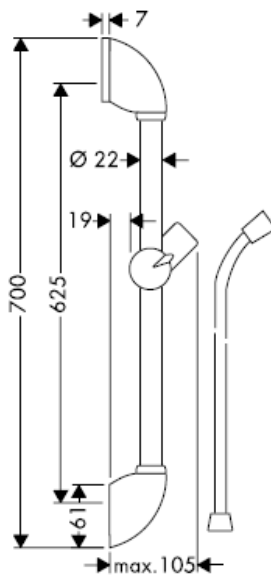

莲蓬头杆27824XXX只用于出口，因此在德国买不到！

**Selecta/Unica'B 27780000**

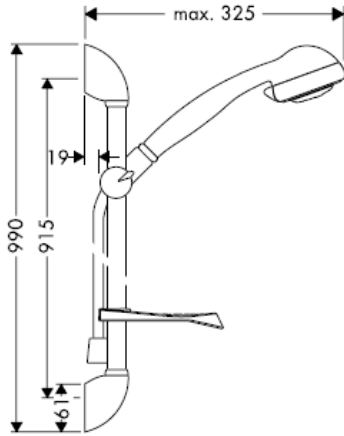

**Selecta/Unica'B 27781000**

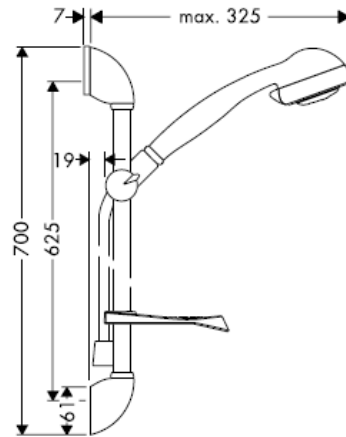

莲蓬头杆27824XXX只用于出口，因此在德国买不到！

**Selecta 2jet/Unica'B 27786000**

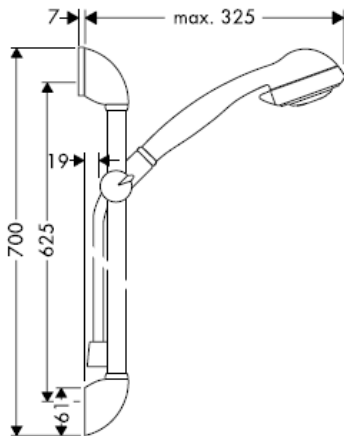

莲蓬头杆27824XXX只用于出口，因此在德国买不到！

## Selecta

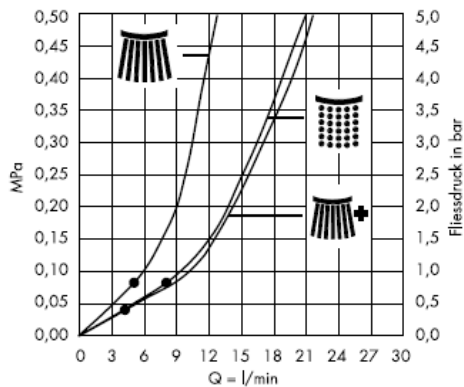

## Selecta 2jet

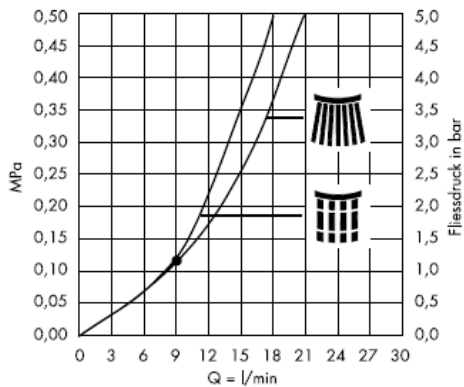

从•开始，正常功能得以保证。



普通水流



正常喷头 +  
Waterdimmer®  
(流量限制器)



柔和水流



按摩喷嘴

## 技术参数

工作压强:	max. 0,6 MPa
推荐工作压强: (1 MPa = 10 巴 = 147 PSI)	0,1 – 0,4 MPa
热水温度:	max 60°C

如果水压达到1.5巴以上，汉斯格雅单手柄龙头可以和液压式或热控式直流式热水器一起使用。

在安装产品的位置，安装人员必须确保安装面的墙面是平的（没有突出物或瓷砖没有突起），墙体结构适合产品的安装并没有弱点。包装内的膨胀螺丝只适用于混凝土墙体。对于其他墙体结构必须咨询膨胀螺丝生产商的建议。

## 检验标记

	DVGW	P-IX	SVGW	ACS	NF	WRAS	KIWA
27700XXX							
27705XXX							
27780000							
27781000				X			
27786000				X			

必须装上花洒所附带的滤网密封垫，以过滤管道里的杂质污物。杂质污物会影响花洒的功能和/或损坏花洒的功能部件，由此而产生的产品损坏不属于汉斯格雅的保修范围。

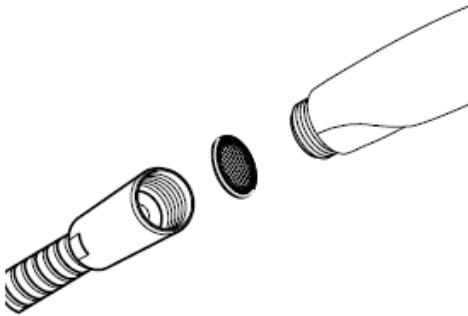

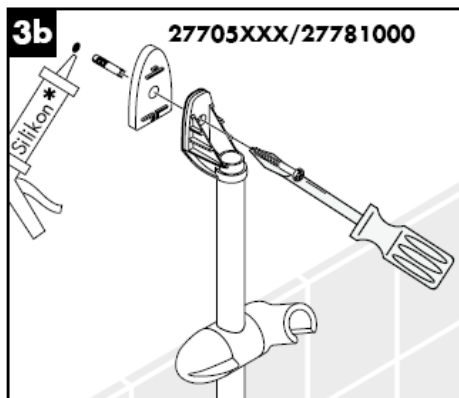
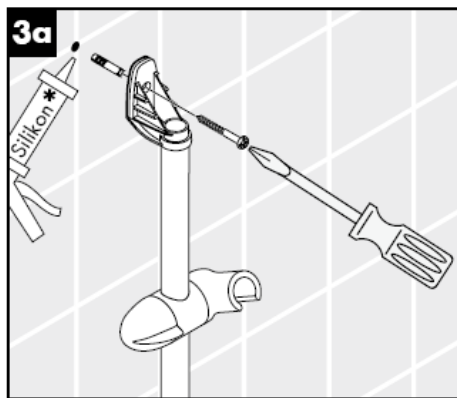
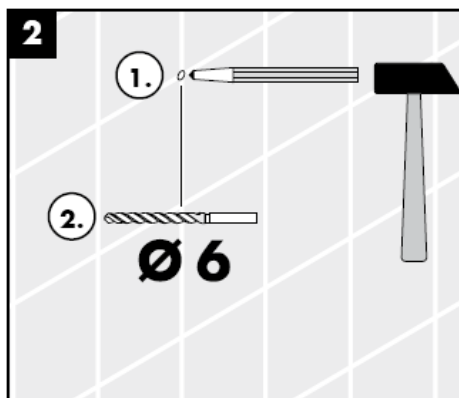
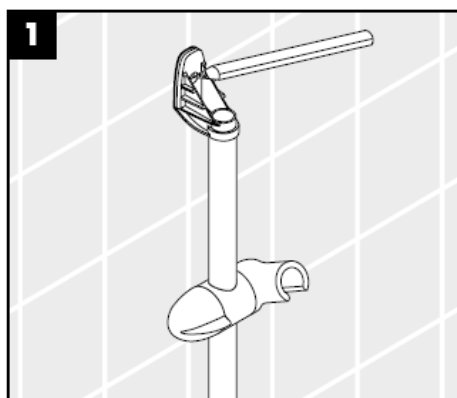

\* 硅胶（不含醋酸）

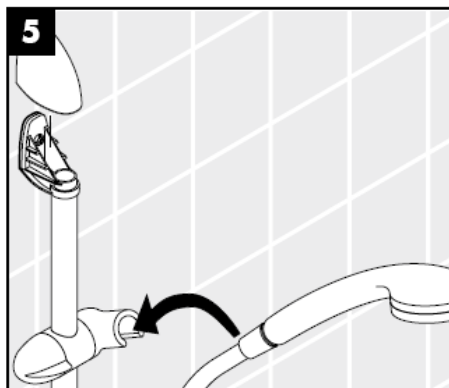
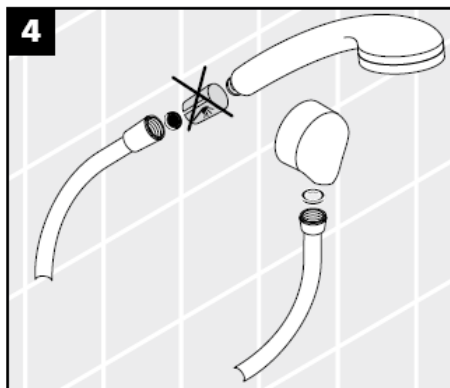

**Cassetta'B** 28686000

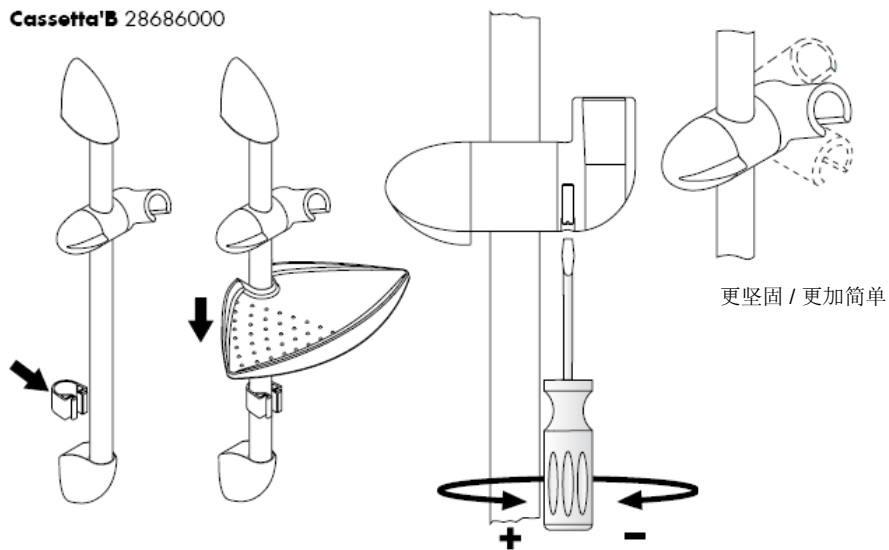

## 清洗

有了Rubit®, 手工清洁功能, 要去掉喷头上的水垢, 只需简单地搓除即可。

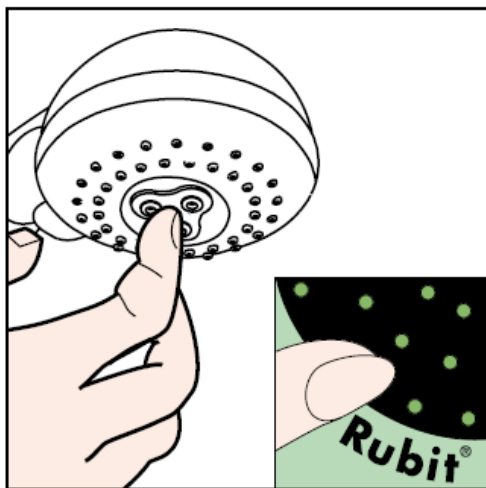

## 清洗说明

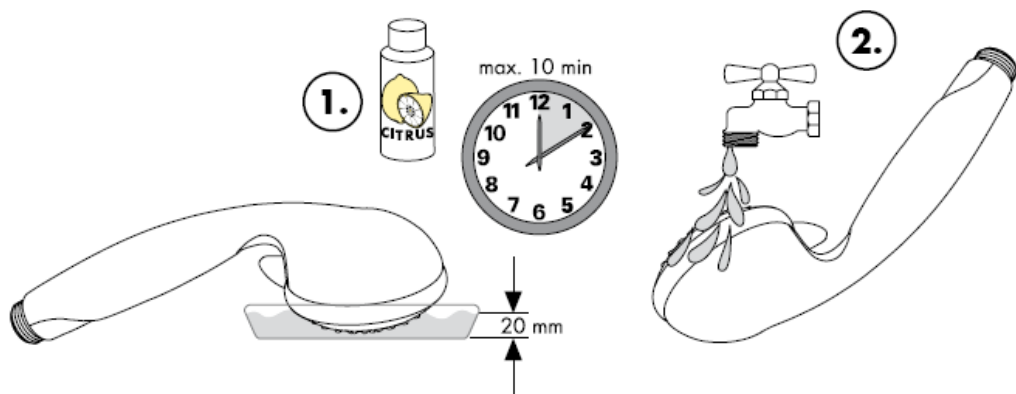

**hansgrohe**

Hansgrohe · Postfach 1145 · D-77761 Schiltach · Telefon +49 (0) 78 36/51-1282 · Telefax +49 (0) 7836/511440  
E-Mail: [info@hansgrohe.com](mailto:info@hansgrohe.com) · Internet: [www.hansgrohe.com](http://www.hansgrohe.com)

05/2007  
9.08069.04  
中文

# Инструкция по монтажу



**Unica'B**  
27700XXX



**Unica'B**  
27705XXX

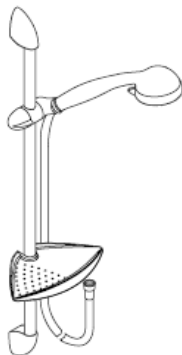

**Selecta/Unica'B**  
27780000/  
27781000



**Selecta 2jet/Unica'B**  
27786000

**hansgrohe**



Оптимальное функционирование гарантируется только при использовании в комбинации с ручными душами Hansgrohe и душевыми шлангами Hansgrohe. Душевые шланги подходят только для подсоединения душей к арматуре. Не устанавливайте дополнительных затворов между шлангом и арматурой!

**Unica'B 27700XXX**

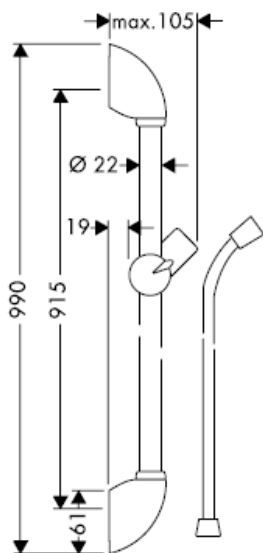

**Unica'B 27705XXX**

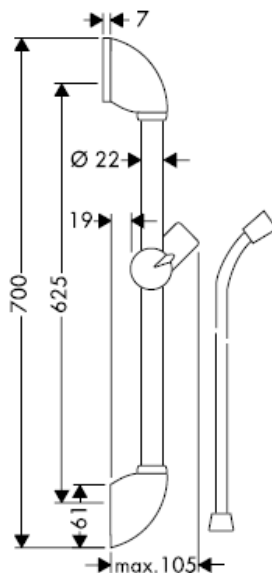

Опора для душа 27824XXX поставляется только на экспорт и не продается в Германии!

**Selecta/Unica'B 27780000**

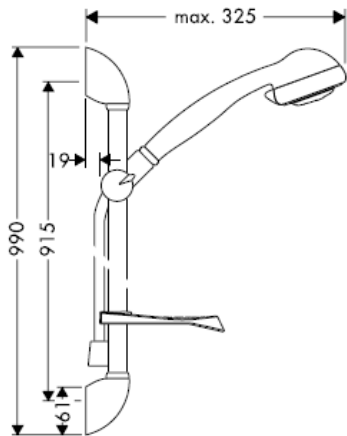

**Selecta/Unica'B 27781000**

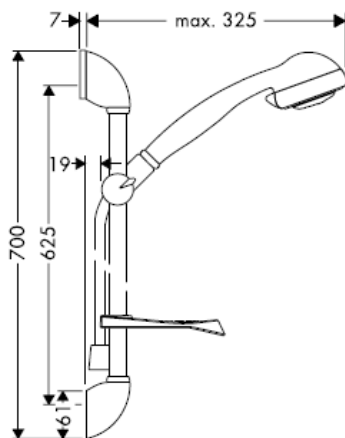

Опора для душа 27824XXX поставляется только на экспорт и не продается в Германии!

**Selecta 2jet/Unica'B 27786000**

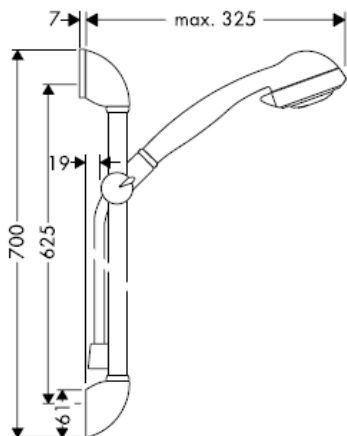

Опора для душа 27824XXX поставляется только на экспорт и не продается в Германии!

## Selecta

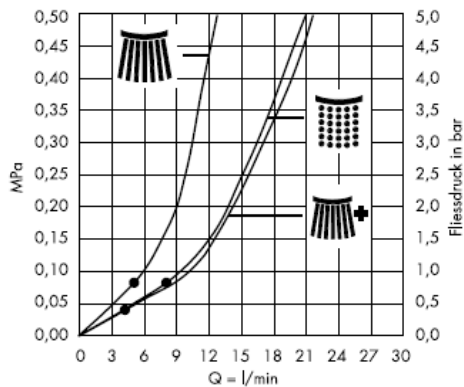

## Selecta 2jet

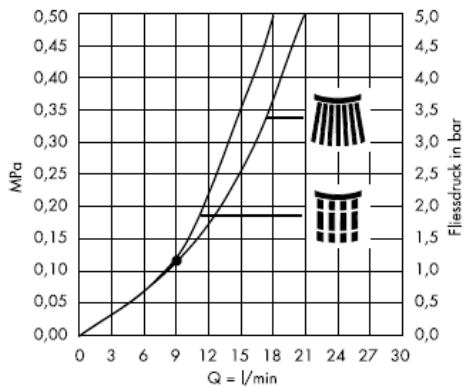

Гарантированное функционирование при показателях свыше •.



Нормальная струя



Нормальная струя +  
Waterdimmer®  
(ограничитель  
расхода воды )



Мягкая струя



Массажная струя

## Технические данные

Рабочее давление: max. 0,6 МПа  
Рекомендуемое рабочее давление: 0,1 – 0,4 МПа  
(1 МПа = 10 бар = 147 PSI)  
Температура горячей воды: max 60°C

Однорычажные смесители фирмы HANSGROHE можно использовать с электроводонагревателями бойлерного типа при минимальном давлении 0,15 МПа.

При монтаже изделия квалифицированным персоналом необходимо следить за тем, чтобы, поверхность крепления была плоской во всей зоне крепления (без выступающих швов или смещения плитки), структура стен подходила для монтажа изделия и, в частности, не имела слабых мест. Прилагаемые винты и дюбели предназначены только для бетона. При других типах стен необходимо соблюдать указания производителей дюбелей.

## Знак технического контроля

	DVGW	P-IX	SVGW	ACS	NF	WRAS	KIWA
27700XXX							
27705XXX							
27780000							
27781000				X			
27786000				X			

Для предотвращения попадания частиц грязи из водопроводной сети необходимо установить фильтр, прилагаемый к ручному душу. Частицы грязи могут нарушить отдельные функции и/или привести к повреждению функциональных деталей ручного душа. Hansgrohe не несет ответственность за повреждения вследствие отсутствия фильтра.

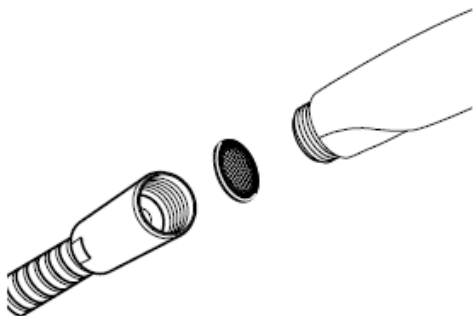

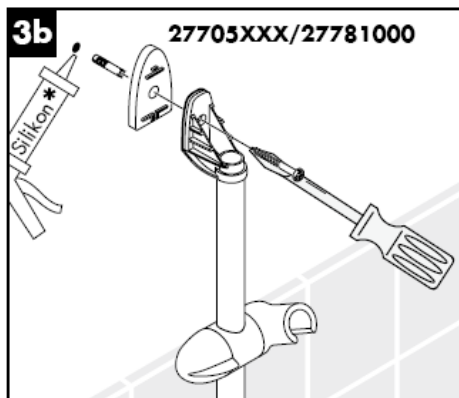
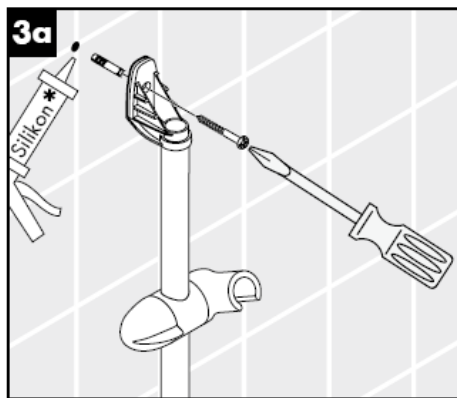
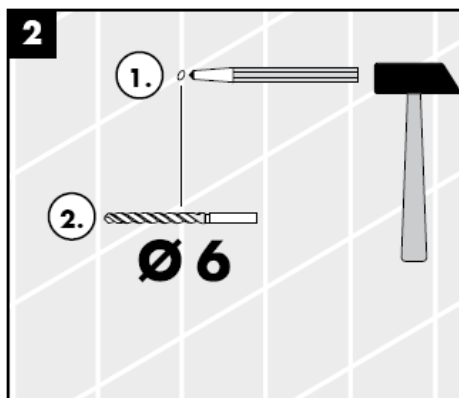
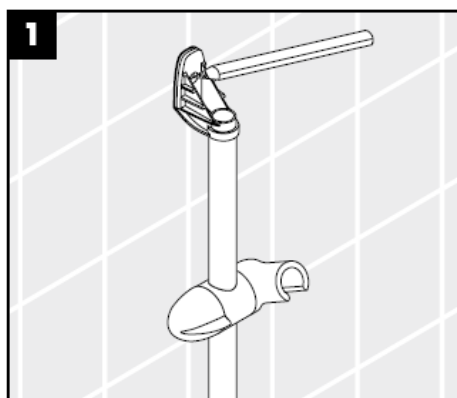

\* Силикон (не содержит уксусной кислоты!)

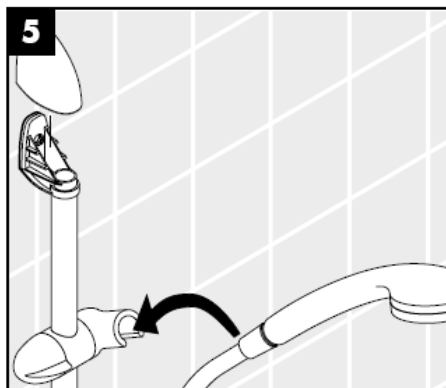
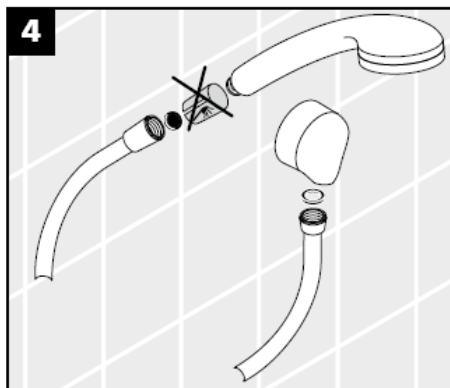

**Cassetta'B** 28686000

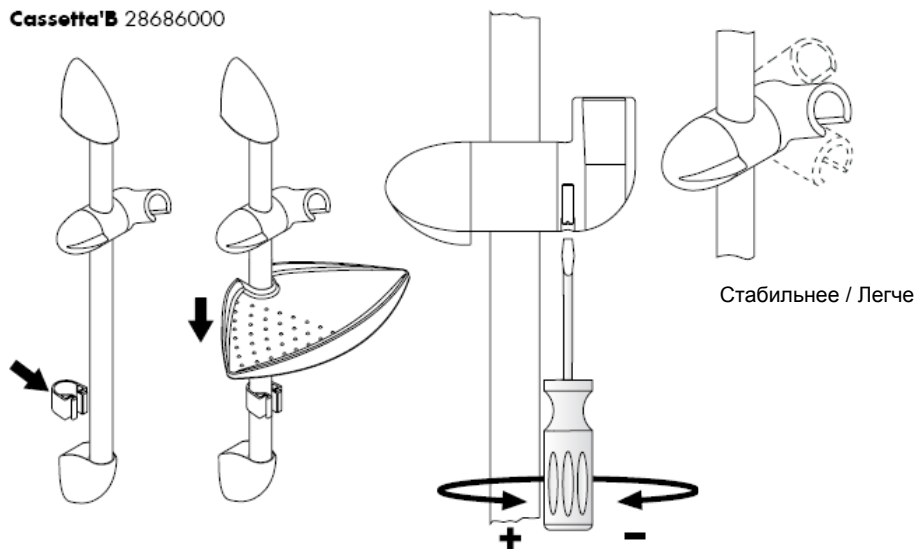

## Очистка

система Rubit® позволяет удалять известковые отложения, достаточно провести по эластичной поверхности аэратора пальцем, как известковые отложения будут удалены.



### Руководство по уходу за изделием

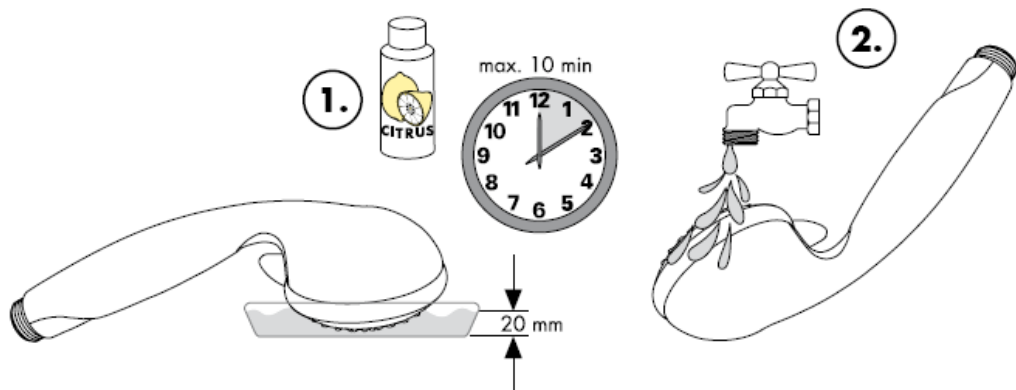

**hansgrohe**

# Szerelési útmutató

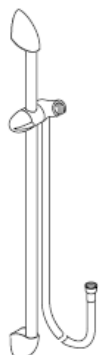

**Unica'B**  
27700XXX



**Unica'B**  
27705XXX

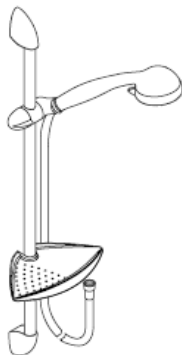

**Selecta/Unica'B**  
27780000/  
27781000



**Selecta 2jet/Unica'B**  
27786000

**hansgrohe**



A megfelelő működést csak Hansgrohe kézzuhanyokkal és Hansgrohe zuhanycsövekkel garantáljuk. A zuhanycsövek kizárólag zuhanyok csaptelepekkel való összekötésére alkalmasak. A zuhanycső után (folyásirány szerint) elzárás beszerelése nem engedélyezett!

**Unica'B 27700XXX**

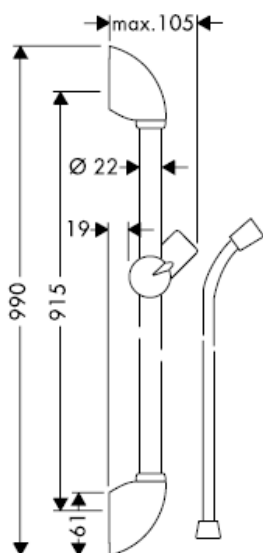

**Unica'B 27705XXX**

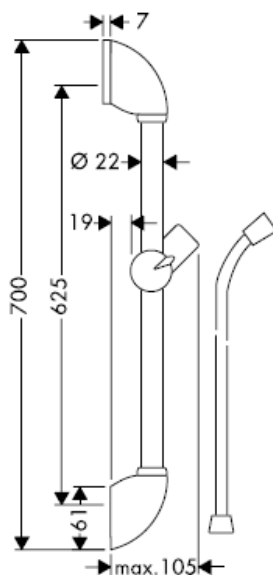

A 27824XXX zuhanyrúd kizárólag exportra készül, ezért Németországban nem kapható!

**Selecta/Unica'B 27780000**

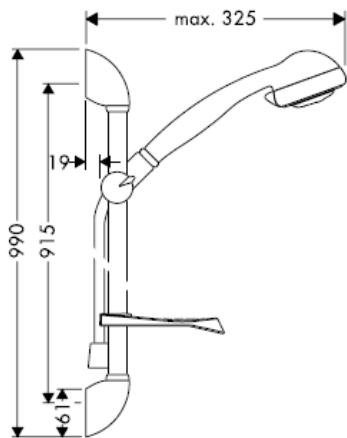

**Selecta/Unica'B 27781000**

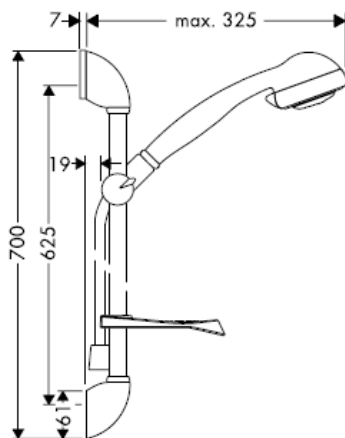

A 27824XXX zuhanyrúd kizárólag exportra készül, ezért Németországban nem kapható!

**Selecta 2jet/Unica'B 27786000**

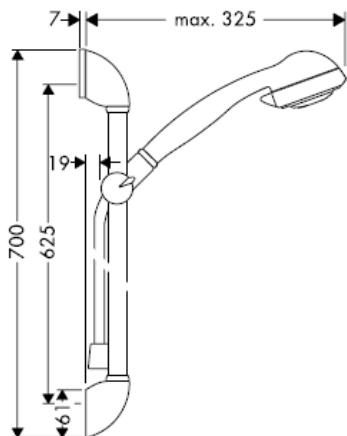

A 27824XXX zuhanyrúd kizárólag exportra készül, ezért Németországban nem kapható!

## Selecta

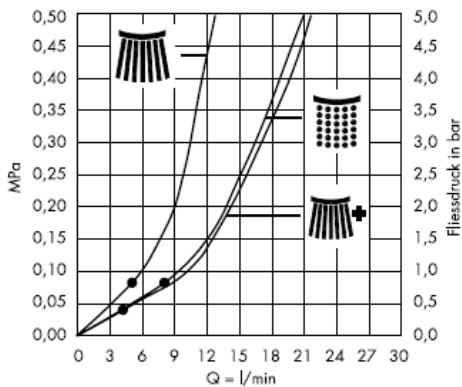

## Selecta 2jet

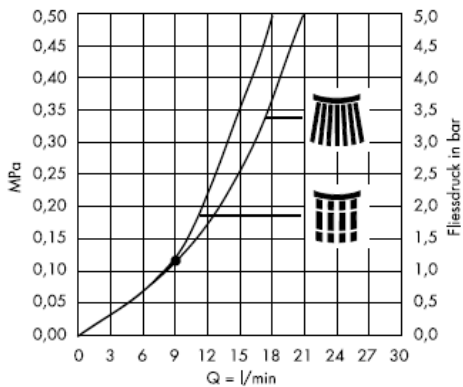

A • -től működik az adott funkció.



Normálsugár



Normálsugár +  
Waterdimmer  
(átfolyásszabályozó)



Lágy sugár



Masszázs-sugár

## Műszaki adatok

Üzemi nyomás:	max. 0,6 MPa
Ajánlott üzemi nyomás: (1 MPa = 10 bar = 147 PSI)	0,1 – 0,4 MPa
Forróvíz hőmérséklet:	max 60°C

A Hansgrohe egykaros keverő csaptelepek beépíthetők hidraulikus- és hőszabályozással ellátott átfolyós vízmelegítőknél egyaránt, ha a víznyomás legalább 0,15 MPa.

Miközben szakképzett szakember végzi a termék felszerelését, ügyelni kell arra, hogy a rögzítési felületek a rögzítési terület teljes egészén síkok (nincsenek kiálló fugák vagy csempezések), a fal felépítése alkalmas a termék felszereléséhez, és különösképpen, hogy nincsenek benne gyenge pontok. A mellékelt csavarok és dübelek csak betonhoz alkalmasak. Egyéb falzatoknál figyelembe kell venni a dübelgyártó gyártói utasításait.

## Vizsgajel

	DVGW	P-IX	SVGW	ACS	NF	WRAS	KIWA
27700XXX							
27705XXX							
27780000							
27781000				X			
27786000				X			

A kézi zuhanyhoz csomagolt szűrőtömítést be kell szerelni a vízhálózatból származó szennyeződések kiküszöbölésére. A beáramló szennyeződések akadályozhatják és / vagy teljesen tönkre is tehetik a zuhany funkcióit. Az ezekből adódó károkért a Hansgrohe nem felel.

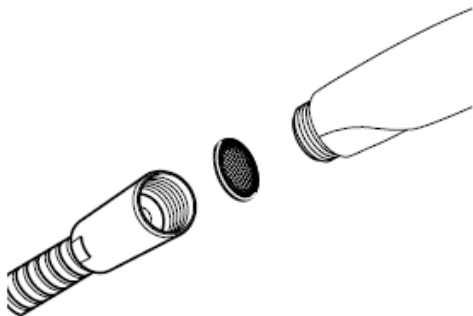

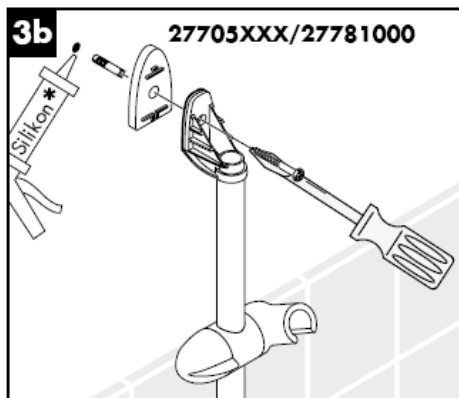
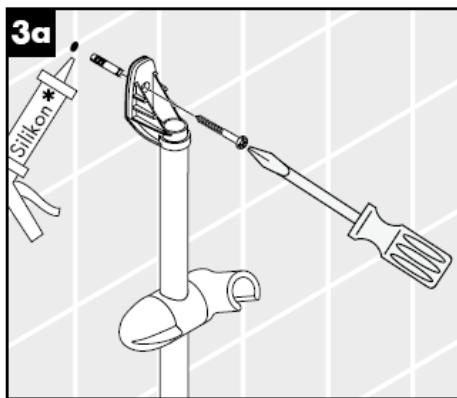
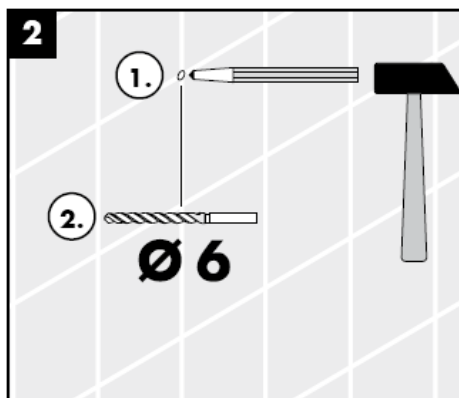
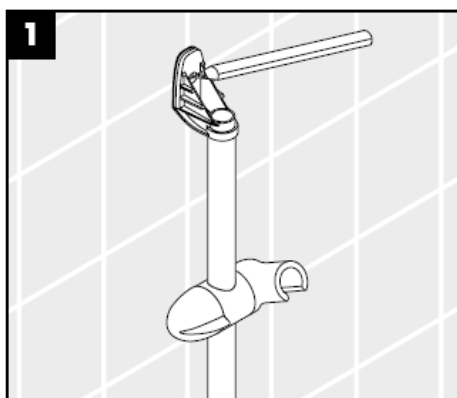

\* Szilikon (ecetsavmentes!)

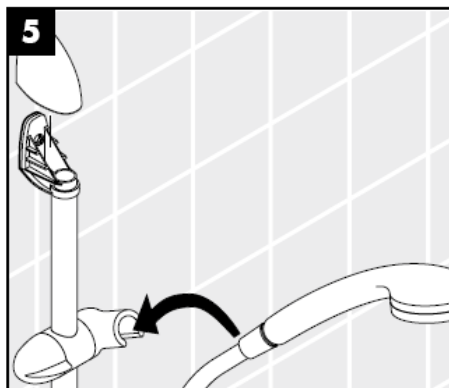
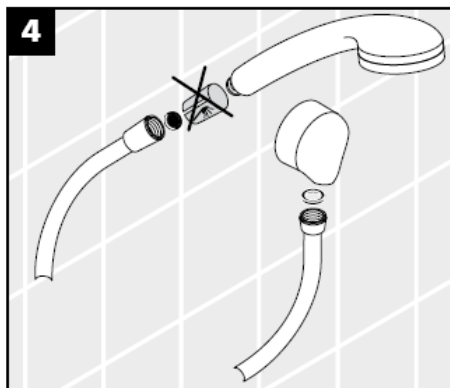

**Cassetta'B** 28686000

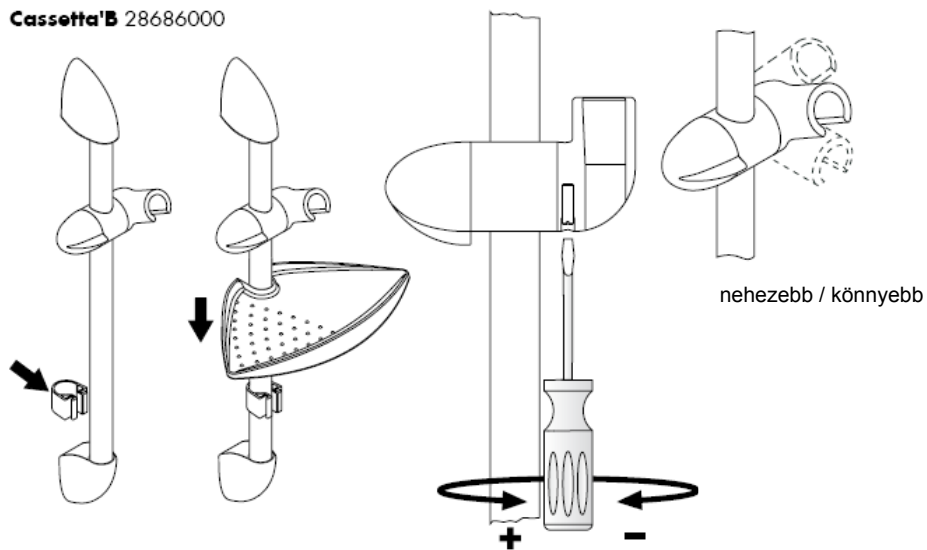

## Tisztítás

A Rubit® manuális tisztítófunkciónak köszönhetően a vízsugárnyílások egyszerű ledörzsöléssel megtisztíthatók a vízkőtől.



## Ápolási tanácsok

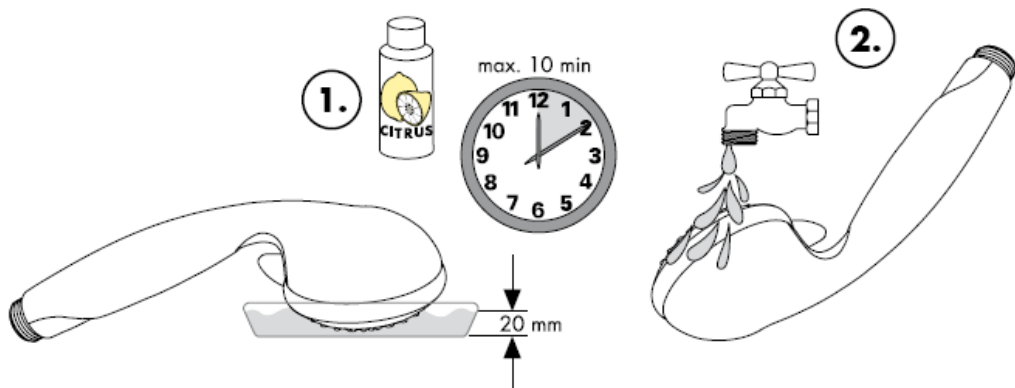

**hansgrohe**

# Asennusohje

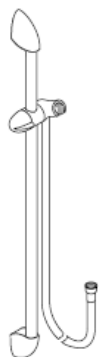

**Unica'B**  
27700XXX



**Unica'B**  
27705XXX

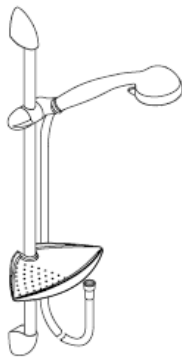

**Selecta/Unica'B**  
27780000/  
27781000



**Selecta 2jet/Unica'B**  
27786000

**hansgrohe**



Optimaalinen toiminta on taattuna vain Hansgrohe käsisuihkuja ja Hansgrohe suihkuletkuja käytettäessä. Suihkuletkut soveltuvat vain käsisuihkun liittämiseen armatuureihin. Letkun jälkeen virtaussuunnassa oleva sulkuventtiili ei ole sallittua!

**Unica'B 27700XXX**

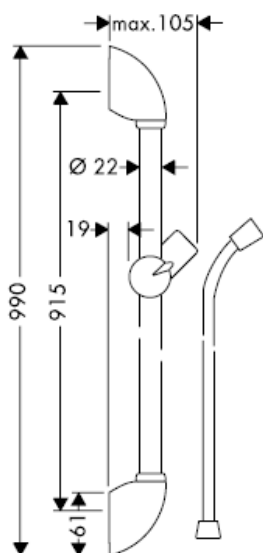

**Unica'B 27705XXX**

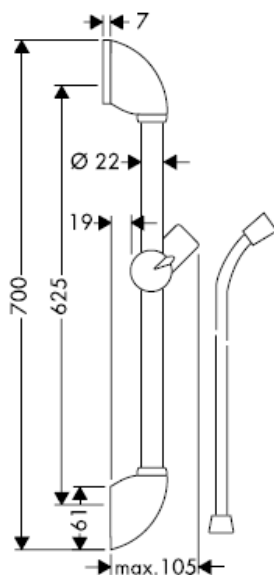

Suihkutanko 27824XXX on tarkoitettu vain vientiin ja sitä ei siksi ole Saksassa saatavilla!

**Selecta/Unica'B 27780000**

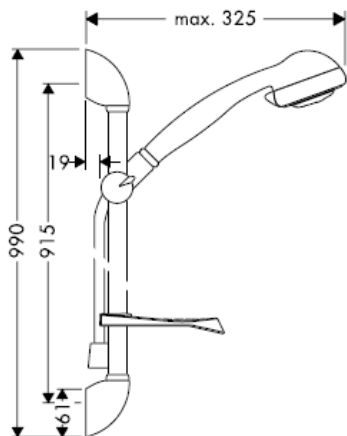

**Selecta/Unica'B 27781000**

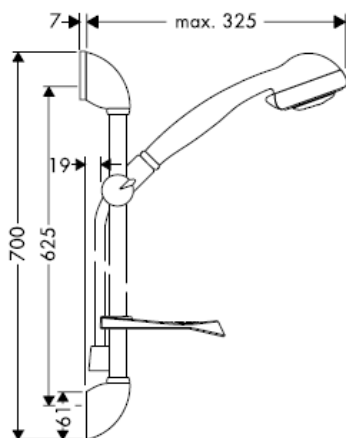

Suihkutanko 27824XXX on tarkoitettu vain vientiin ja sitä ei siksi ole Saksassa saatavilla!

**Selecta 2jet/Unica'B 27786000**

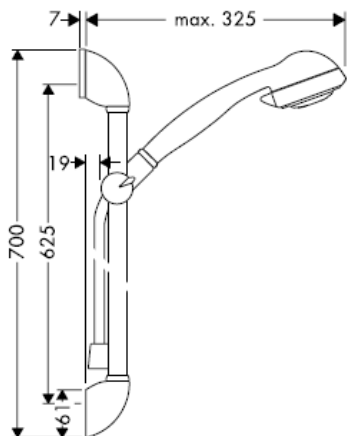

Suihkutanko 27824XXX on tarkoitettu vain vientiin ja sitä ei siksi ole Saksassa saatavilla!

## Selecta

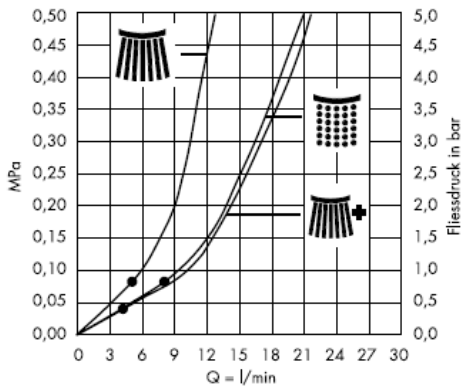

## Selecta 2jet

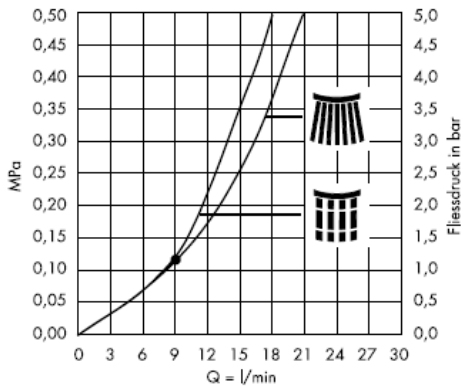

Tämä toiminta on taattuna • alkaen.



Normaalisuihku



Normaalisuihku +  
Waterdimmer®  
(virtauksenrajoitin)



Pehmosuihku



Hierontasuihku

## Tekniset tiedot

Käyttöpaine:	max. 0,6 MPa
Suosittelu käyttöpaine: (1 MPa = 10 bar = 147 PSI)	0,1 – 0,4 MPa
Kuuman veden lämpötila:	max 60°C

Hansgrohe yksivipuisia sekoittimia voi käyttää hydraulisesti tai termisesti ohjattujen läpivirtauskuumentimien yhteydessä, jos virtauspaine on vähintään 0,15 MPa.

**Kun pätevä ammattihenkilöstö suorittaa tuotteen asennusta, on huomioitava, että kiinnityspinta on koko kiinnityksen alueella tasainen (ei ulkonevia saumoja tai laattojen tasomuutoksia) ja, että seinän rakenne soveltuu tuotteen asentamiseen eikä siinä ole heikkoja kohtia. Mukana olevat kiinnitysruuvit ja kiinnitysankkurit soveltuvat betoniin kiinnittämiseen. Kiinnitettäessä tuotetta muihin seinärakenteisiin, noutata kiinnittimien valmistajan ohjeita.**

## Koestusmerkki

	DVGW	P-IX	SVGW	ACS	NF	WRAS	KIWA
27700XXX							
27705XXX							
27780000							
27781000				X			
27786000				X			

Käsisuihkun mukana toimitettu sihtitiiviste on asennettava paikalleen, jotta lian huuhtoutuminen vesijohtoverkostosta käsisuihkuun estyy. Huuhtoutuvat likahiukkaset voivat häiritä suihkun toimintaa tai vahingoittaa toimintaosia, Hansgrohe ei vastaa tästä aiheutuneista vahingoista.

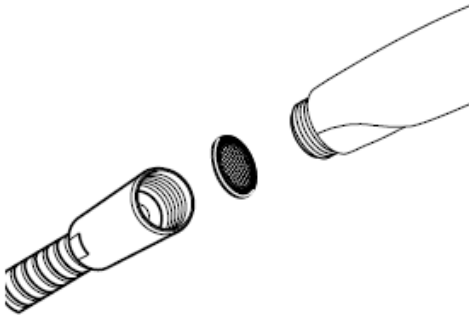

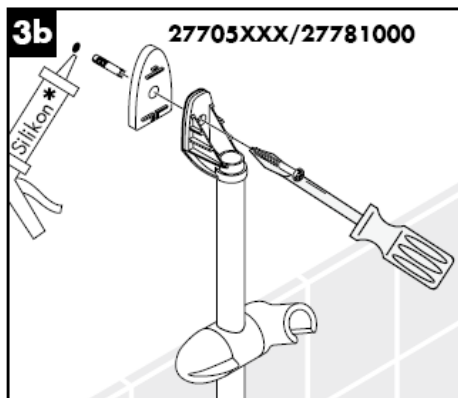
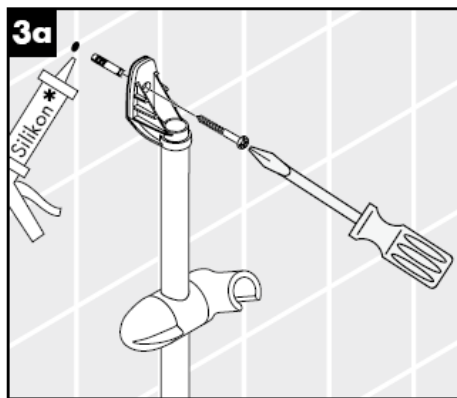
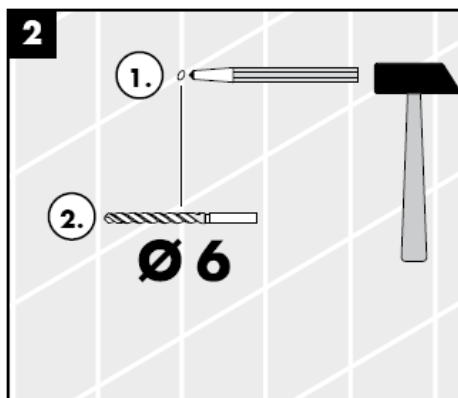
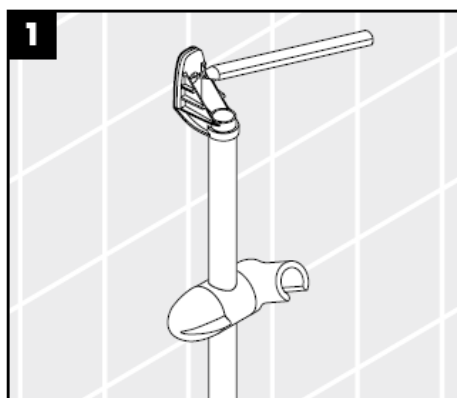

\* Silikoni (etikkahappovapaa!)

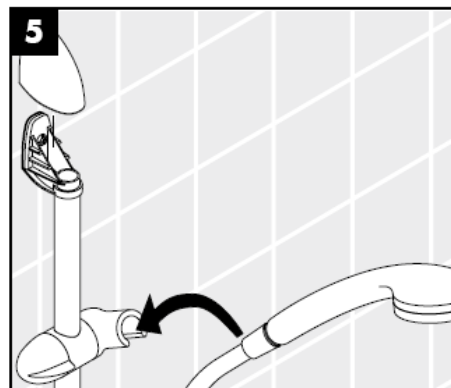
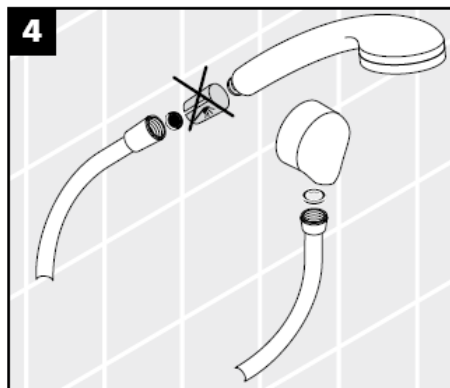

**Cassetta'B** 28686000

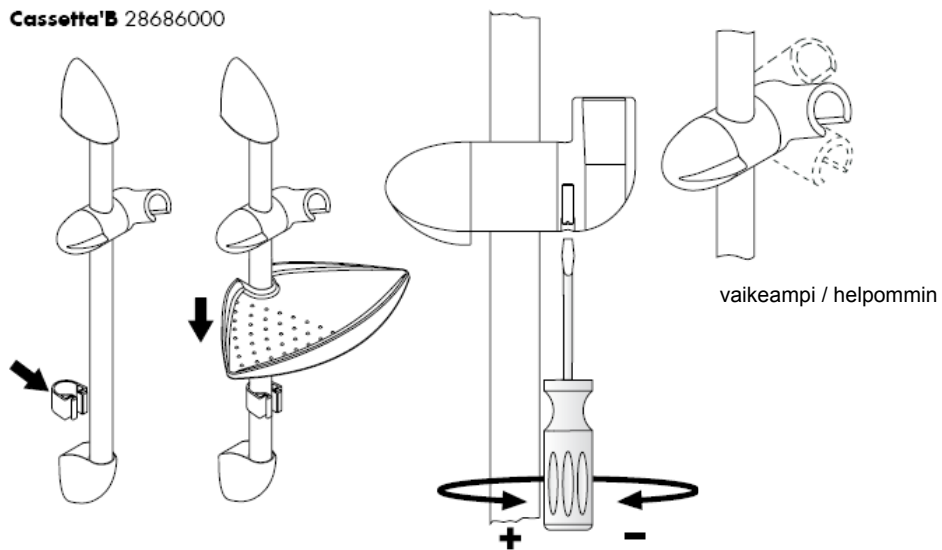

## Puhdistus

Rubit® –käsitoiminen kalkinpoistojärjestelmä on helppo käyttää: hiero sormella ja vedentulo on taas esteetön.



## Hoito-ohje

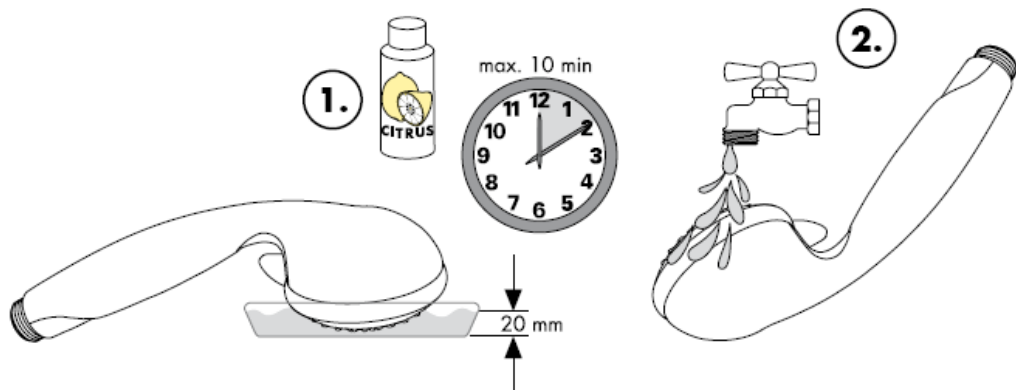

**hansgrohe**

# Monteringsanvisning



**Unica'B**  
27700XXX



**Unica'B**  
27705XXX

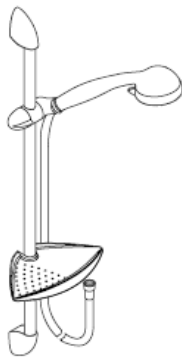

**Selecta/Unica'B**  
27780000/  
27781000



**Selecta 2jet/Unica'B**  
27786000

**hansgrohe**



Optimal funktion garanteras bara tillsammans med Hansgrohe handduschar och Hansgrohe duschslangar. Duschslangar är endast avsedda till att ansluta duschar på blandare. Det är inte tillåtet att lägga in en spärr efter slangen och i flödesriktningen!

**Unica'B 27700XXX**

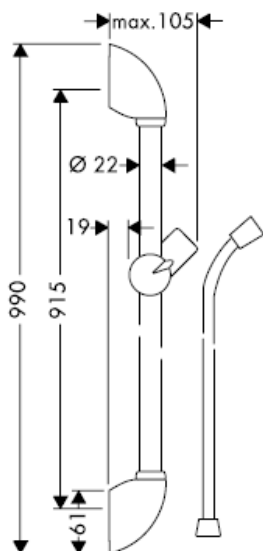

**Unica'B 27705XXX**

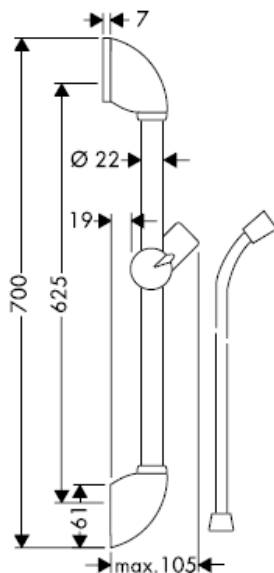

Duschstangen 27824XXX är uteslutande avsedd för export och finns därför inte i Tyskland!

**Selecta/Unica'B 27780000**

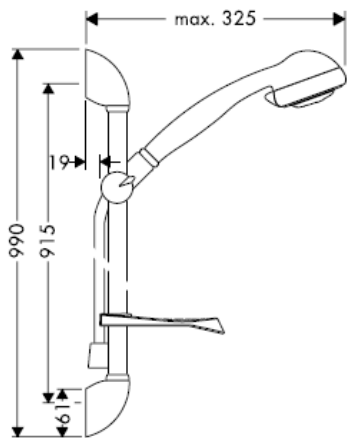

**Selecta/Unica'B 27781000**

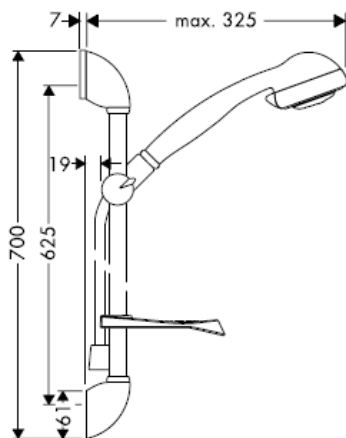

Duschstången 27824XXX är uteslutande avsedd för export och finns därför inte i Tyskland!

**Selecta 2jet/Unica'B 27786000**

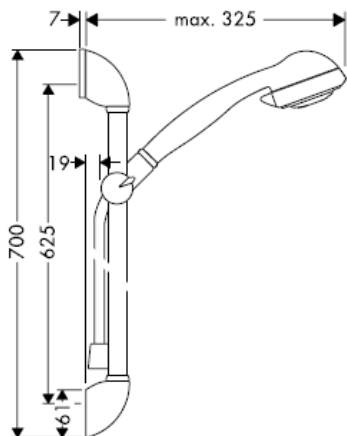

Duschstången 27824XXX är uteslutande avsedd för export och finns därför inte i Tyskland!

## Selecta

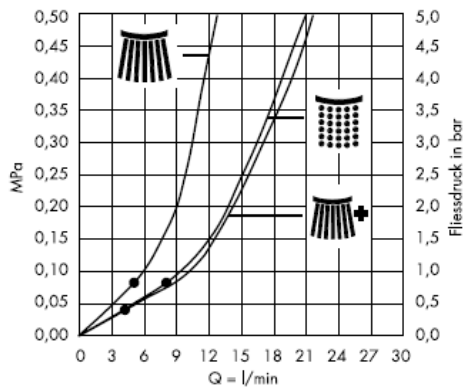

## Selecta 2jet

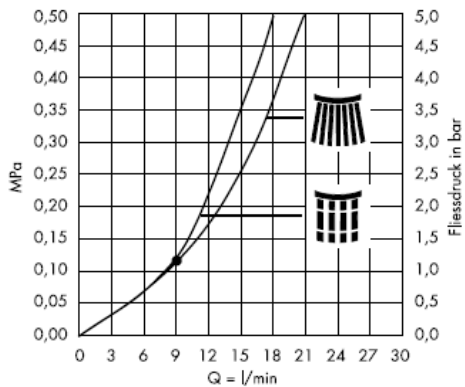

Från • garanteras funktionen.



Normalstråle



Normalstråle +  
Waterdimmer®  
(flödeskontroll)



Softstråle



Massagestråle

## Tekniska data

Driftstryck:	max. 0,6 MPa
Rek. driftstryck: (1 MPa = 10 bar = 147 PSI)	0,1 – 0,4 MPa
Varmvattentemperatur:	max 60°C

Hansgrohe enhandsblandare kan användas tillsammans med hydrauliskt och termiskt styrda varmvattenberedare när flödestrycket uppgår till minst 0,15 MPa.

När kvalificerad fackpersonal monterar produkten är det viktigt att tänka på att monteringsytan är plan i alla delar av arbetsytan (inga fogar som sticker ut eller klinkerförskjutningar), att väggkonstruktionen passar till montering av produkten samt att den inte har svaga punkter. Medföljande skruvar och plugg är endast avsedda för betong. Vid andra väggkonstruktioner skall anvisningarna från pluggtillverkaren beaktas.

## Testsigill

	DVGW	P-IX	SVGW	ACS	NF	WRAS	KIWA
27700XXX							
27705XXX							
27780000							
27781000				X			
27786000				X			

Silpackningen som följer med duschen måste monteras för att undvika att smuts från ledningsnätet tränger in. Smuts som spolats in kan påverka funktionerna och/eller leda till skador på funktionsdelar i duschen. Hansgrohe fransäger sig allt ansvar för skador som kan härledas till detta.

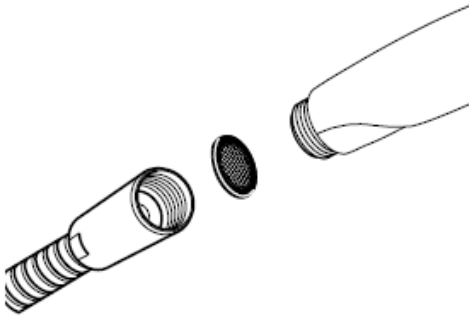

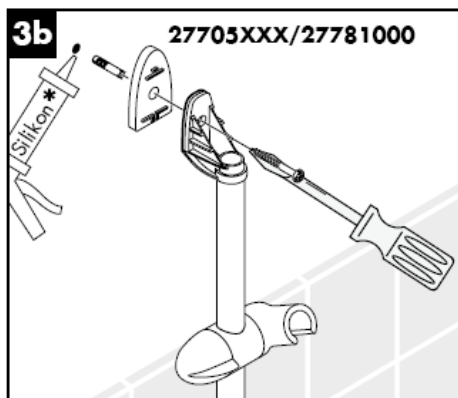
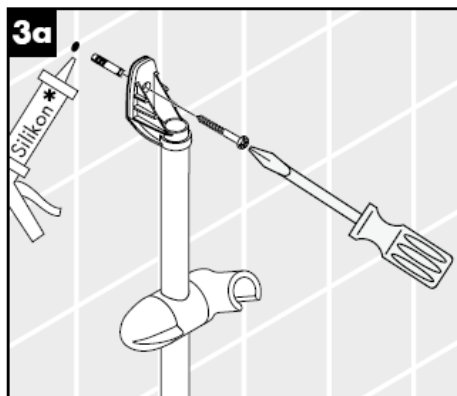
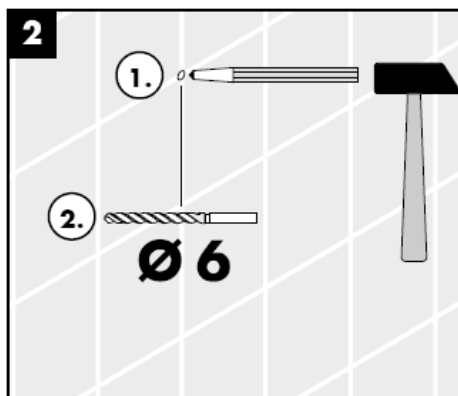
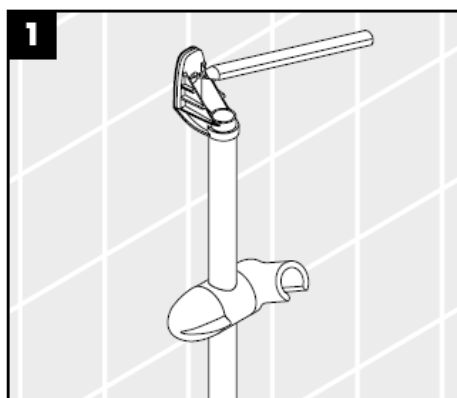

\* Silikon (fri från ättiksyra!)

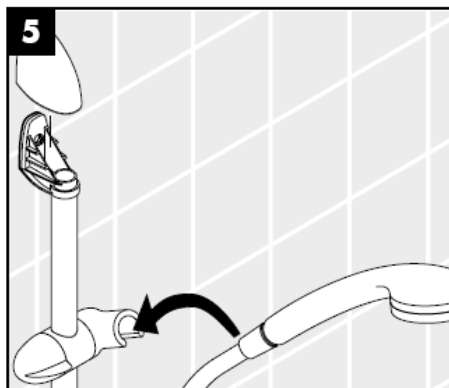
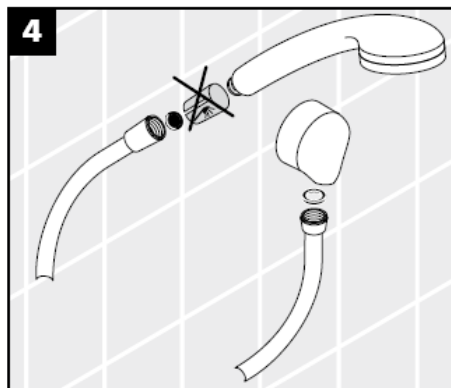

**Cassetta'B** 28686000

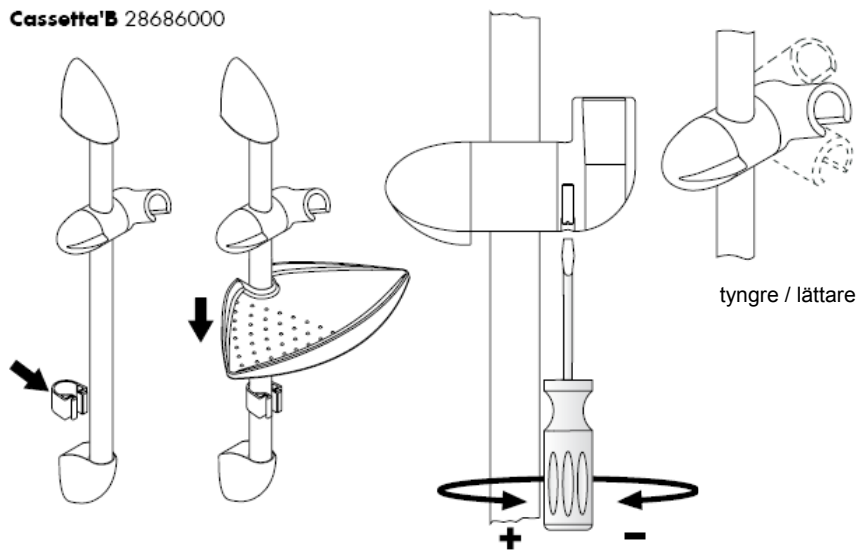

## Rengöring

Med Rubit®, den manuella rengöringsfunktionen, är det lätt att befria strålkanelerna från kalk - de ska bara gnuggas.

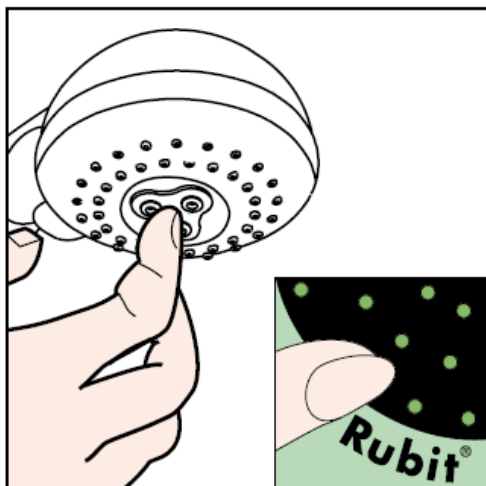

## Skötselanvisningar

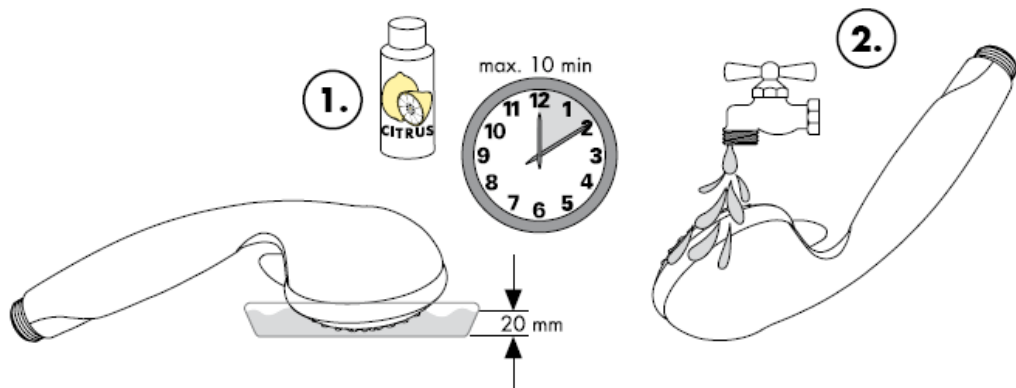

**hansgrohe**

# Montavimo instrukcijos

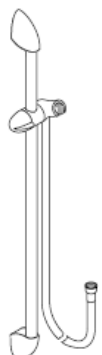

**Unica'B**  
27700XXX



**Unica'B**  
27705XXX

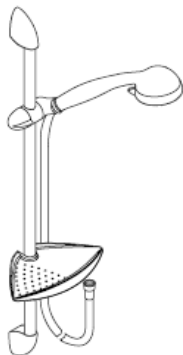

**Selecta/Unica'B**  
27780000/  
27781000



**Selecta 2jet/Unica'B**  
27786000

**hansgrohe**



Optimalus funkcionavimas yra garantuojamas tik naudojant "Hansgrohe" rankų dušus su "Hansgrohe" dušo žarnomis. Dušo žarnos yra pritaikytos tik prijungti dušo galvutę prie vandens maišytuvo. Negalima montuoti vandens uždarymo mechanizmo tarp maišytuvo ir žarnos.

**Unica'B 27700XXX**

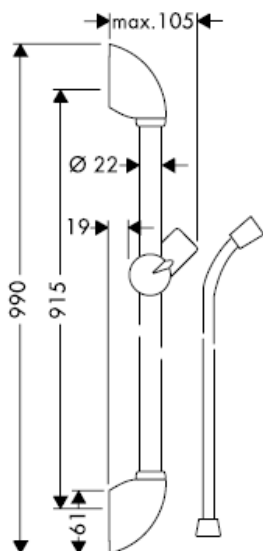

**Unica'B 27705XXX**

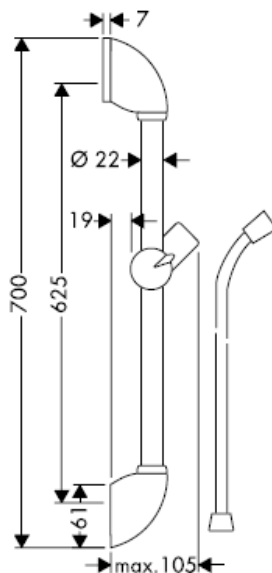

Dušo strypas 27824XXX skirtas tik eksportui, todėl Vokietijoje neparduodamas!

**Selecta/Unica'B 27780000**

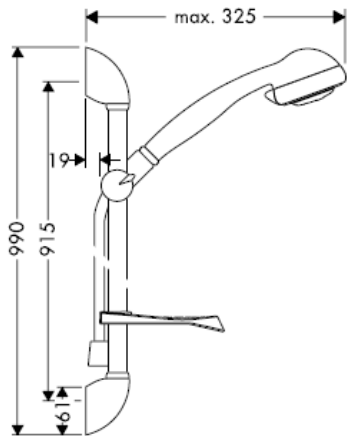

**Selecta/Unica'B 27781000**

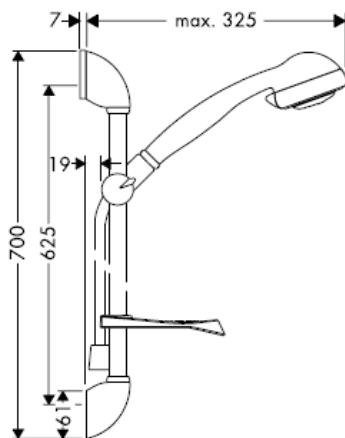

Dušo strypas 27824XXX skirtas tik eksportui, todėl Vokietijoje neparduodamas!

**Selecta 2jet/Unica'B 27786000**

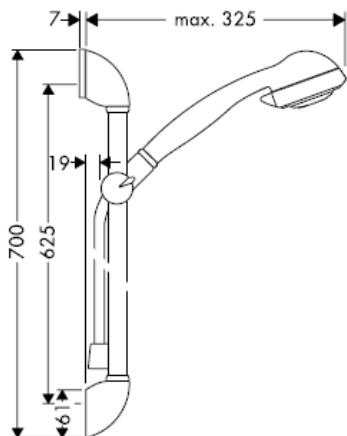

Dušo strypas 27824XXX skirtas tik eksportui, todėl Vokietijoje neparduodamas!

## Selecta

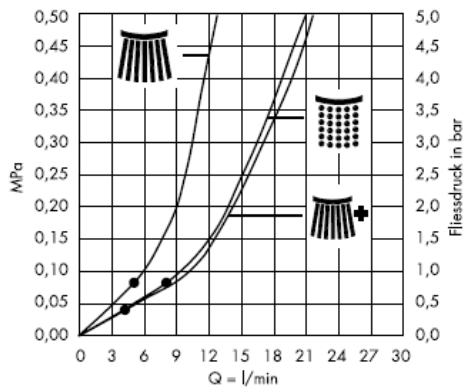

## Selecta 2jet

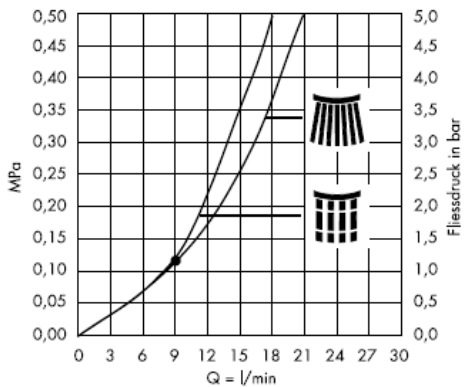

Nuo • funkcionavimas garantuotas



Normali srovė



Normali srovė +  
"Waterdimmer®"  
(Vandens ribotuvas)



Minkšta srovė



Masažinė srovė

## Techniniai duomenys

Darbinis slėgis:	max. 0,6 MPa
Rekomenduojamas slėgis: (1 MPa = 10 barų = 147 PSI)	0,1 – 0,4 MPa
Karšto vandens temperatūra:	max 60°C

"Hansgrohe" vienos rankenėlės maišytuvai gali būti naudojami su hidrauliškai ir termiškai reguliuojamais momentiniais šildikliais, kai vandens slėgis mažesnis kaip 0,15 MPa.

## Bandymo pažyma

	DVGW	P-IX	SVGW	ACS	NF	WRAS	KIWA
27700XXX							
27705XXX							
27780000							
27781000				X			
27786000				X			

Tinklelis, kuris yra rankų dušas pakuotėje, privalo būti įstatytas, kad būtų apsaugota nuo išorės nešvarumų. Nešvarumai gali pakenkti rankų dušas funkcionalumui ir (arba) sugadinti rankų dušas funkcines dalis. Tokiu atveju ""Hansgrohe"" atsakomybės nepriima.

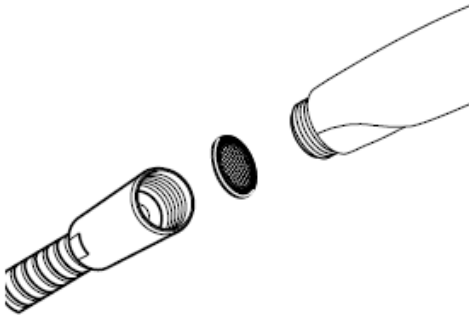

Montuojant produktą, specialistas privalo įsitikinti, kad sienos plotas, prie kurio dedama montavimo plokštė, yra lygus (jokių plytelių ar kitų nelygumų), kad sienos struktūra yra pritaikyta produkto montavimui ir neturi jokių silpnų vietų. Pakuotėje esantys varžtai ir kaiščiai yra skirti tik betonui. Esant kitokiai sienai, varžtus ir kaiščius reikia rinktis pagal paskirtį.

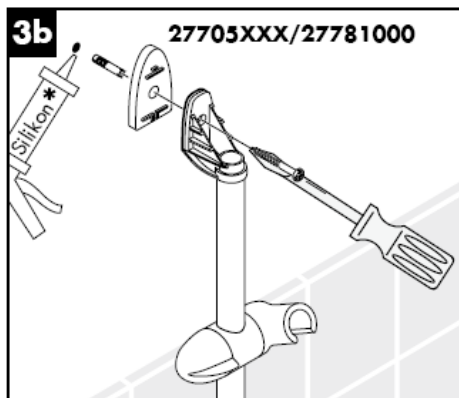
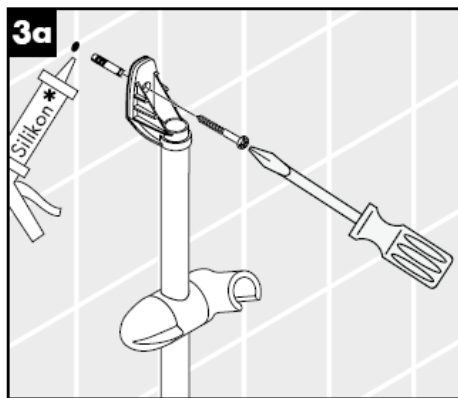
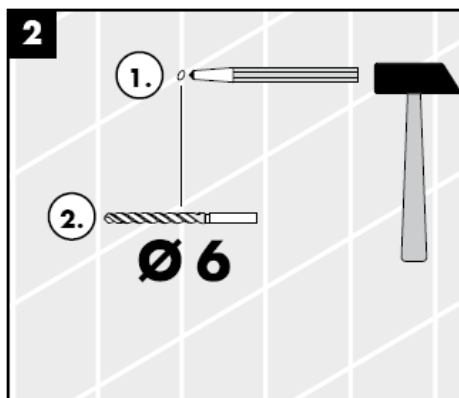
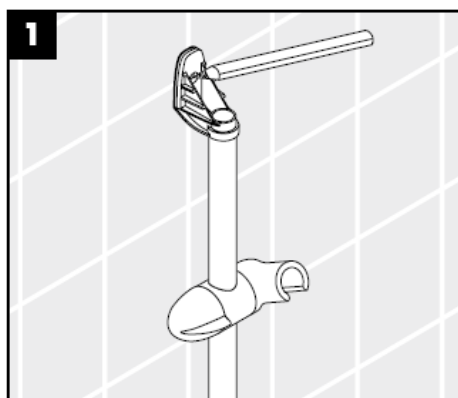

\* Silikonas (be acto rūgšties!)

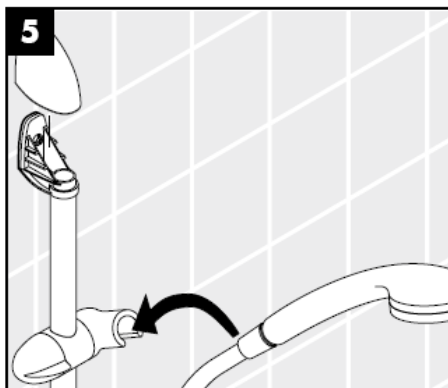
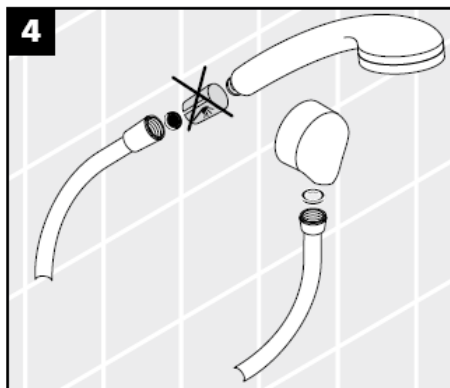

**Cassetta'B** 28686000

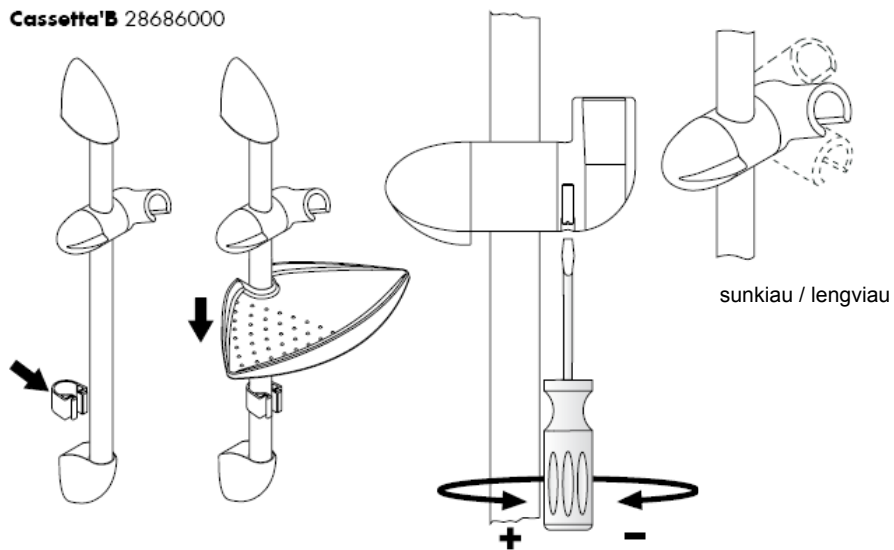

## Valymas

"Rubit®" valymo funkcija apsaugo nuo apkalkėjimo. Užtenka pirštu nubraukti atsiradusius nešvarumus nuo srovės angų.



### Valymo instrukcijos

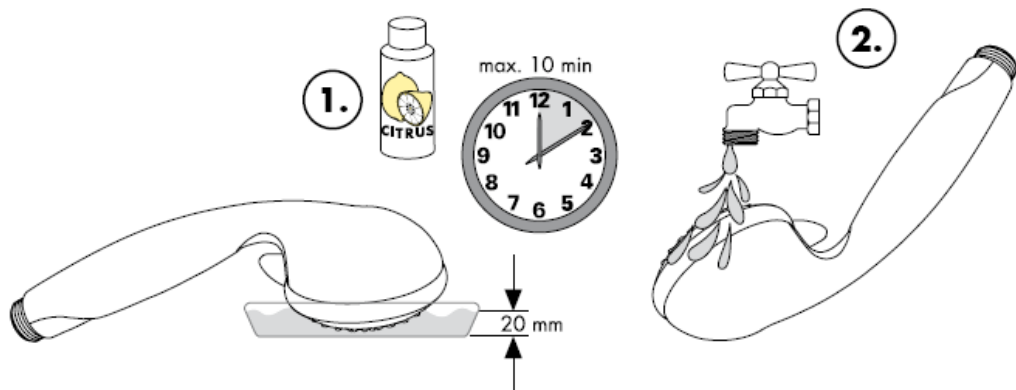

**hansgrohe**

# Uputstva za instalaciju



**Unica'B**  
27700XXX



**Unica'B**  
27705XXX

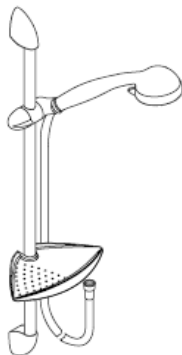

**Selecta/Unica'B**  
27780000/  
27781000



**Selecta 2jet/Unica'B**  
27786000

**hansgrohe**



Optimalno funkcioniranje zajamčeno je jedino u kombinaciji sa Hansgrohe ručnim tuševima i Hansgrohe crijevom za tuš. Crijeva tuša prikladna su jedino za spajanje tuševa na armature. Nije dopušteno zatvaranje crijeva u smjeru protoka vode!

**Unica'B 27700XXX**

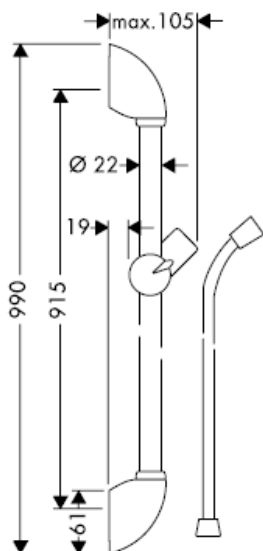

**Unica'B 27705XXX**

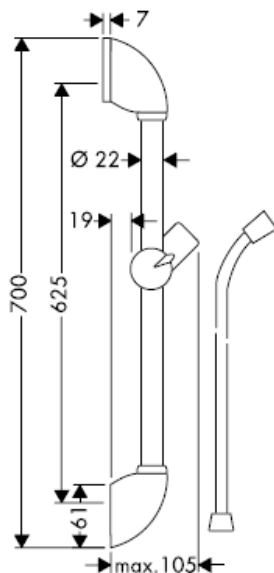

Šipka tuša 27824XXX namijenjena je isključivo za izvoz i ne može se kupiti u Njemačkoj!

**Selecta/Unica'B 27780000**

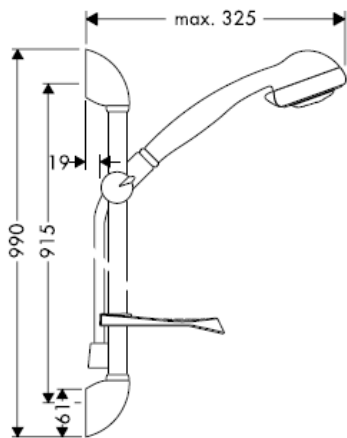

**Selecta/Unica'B 27781000**

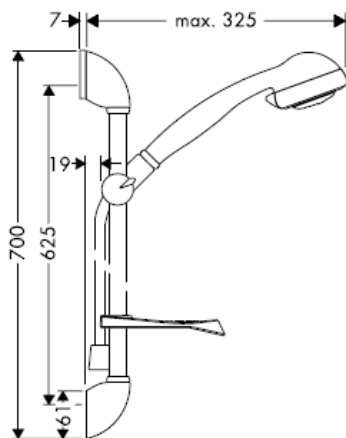

Šipka tuša 27824XXX namijenjena je isključivo za izvoz i ne može se kupiti u Njemačkoj!

**Selecta 2jet/Unica'B 27786000**

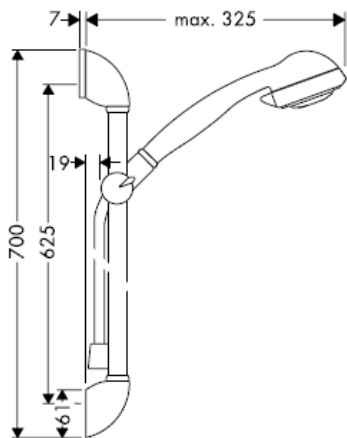

Šipka tuša 27824XXX namijenjena je isključivo za izvoz i ne može se kupiti u Njemačkoj!

## Selecta

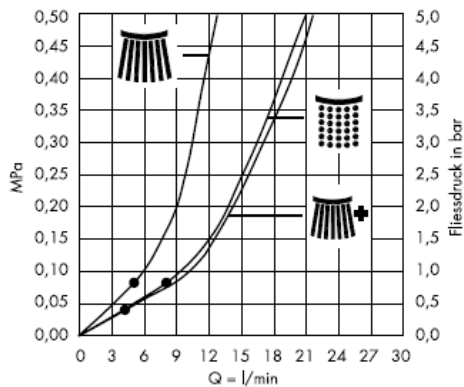

## Selecta 2jet

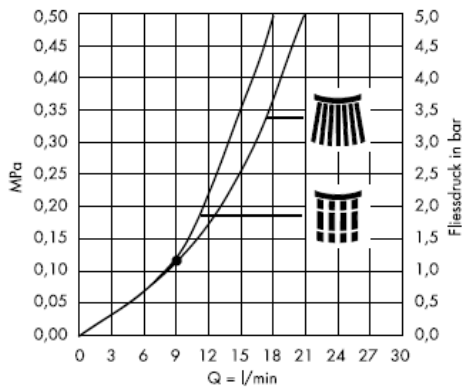

Zajamčena funkcija od • navíše



Normalni mlaz



Normalni mlaz +  
Waterdimmer  
(ograničavač protoka)



Nježni mlaz



Masažni mlaz

## Tehnički podatci

Najveći dopušteni tlak: max. 0,6 MPa  
Preporučeni tlak: 0,1 – 0,4 MPa  
(1 MPa = 10 bara = 147 PSI)  
Temperatura vruće vode: max 60°C

Hansgrohe jednoručne slavine se mogu koristiti sa hidraulični i termički kontroliranim protočnim bojlerima ako je tlak najmanje 0,15 MPa.

Kada proizvod montira kvalificirano stručno osoblje treba paziti da čitava površina na koju se učvršćuje bude ravna (bez istaknutih fuga ili krivljenja pločica), da je zidna konstrukcija primjerena montaži proizvoda te osobito da nema slabih mjesta.

Priloženi vijci i moždanici prikladni su samo za beton. Kod drugih zidnih nadgradnji treba obratiti pažnju na navode proizvođača moždanika.

## Oznaka testiranja

	DVGW	P-IX	SVGW	ACS	NF	WRAS	KIWA
27700XXX							
27705XXX							
27780000							
27781000				X			
27786000				X			

Filter (A) potrebno je ugraditi kako bi se regulirao protok vode i smanjio dotok prljavštine . Ako želite jači protok vode umjesto filtera ugradite rešetku (B) Za eventualna oštećenja uzrokovana prljavštinom proizvođač Hansgrohe nije odgovoran.

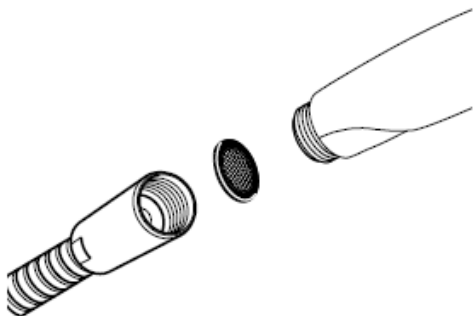

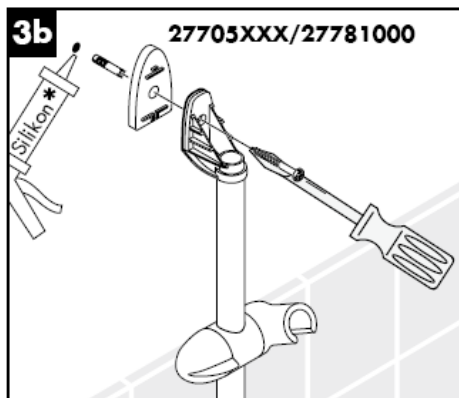
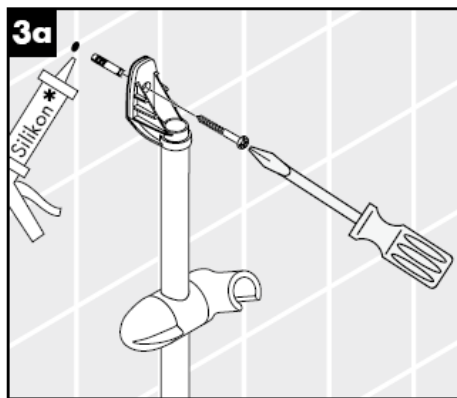
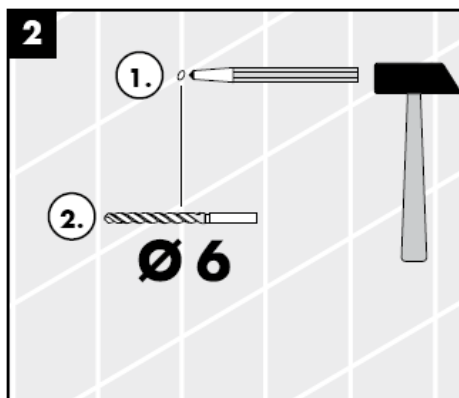
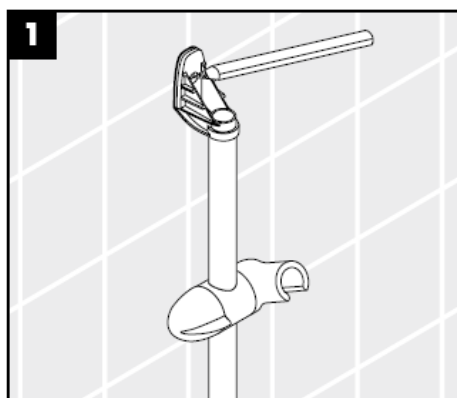

\* Silikon (ne sadrži kiseline)

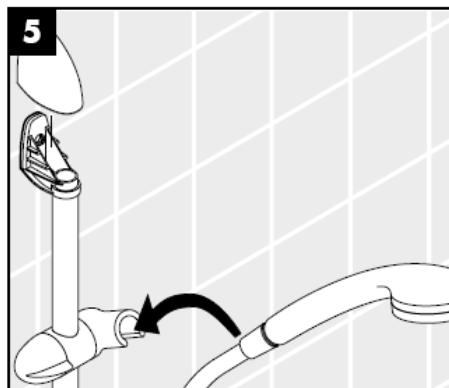
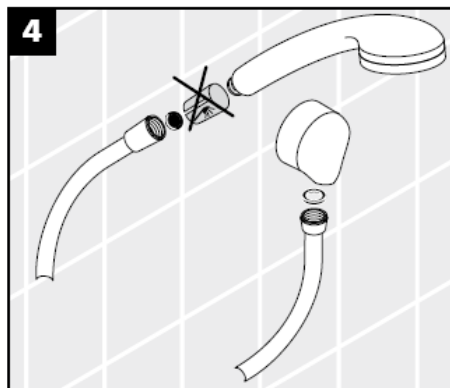

**Cassetta'B** 28686000

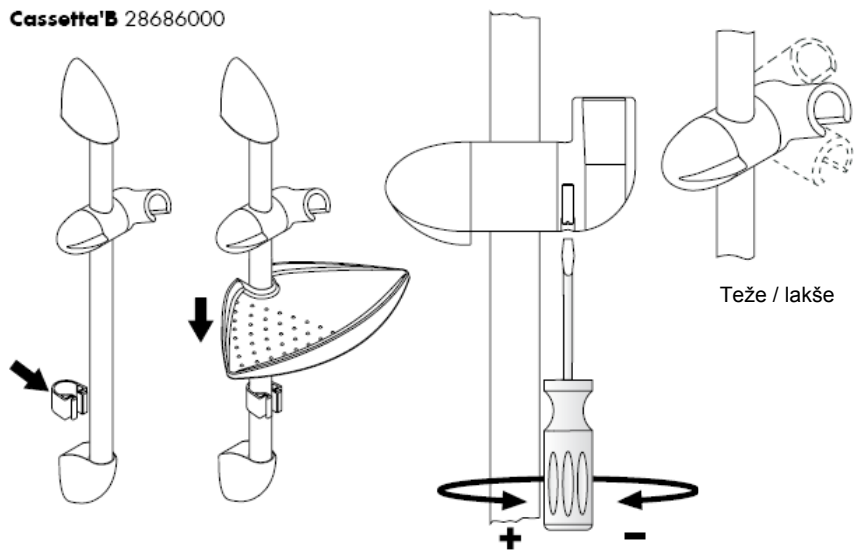

## Čišćenje

Rubit® - ručni sustav za čišćenje omogućuje jednostavnim trljanjem odstranjivanje kamenca sa rupica prskalice tuša.

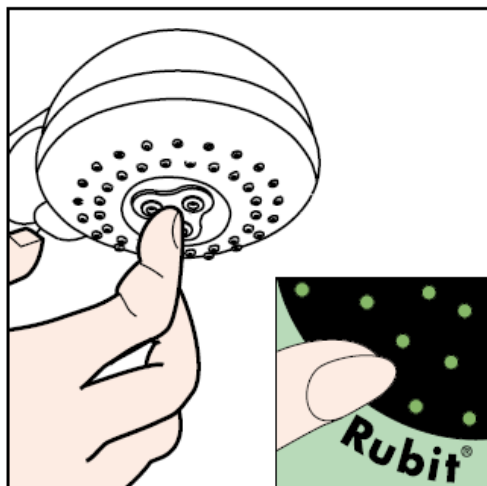

### Uputstva za održavanje i čišćenje

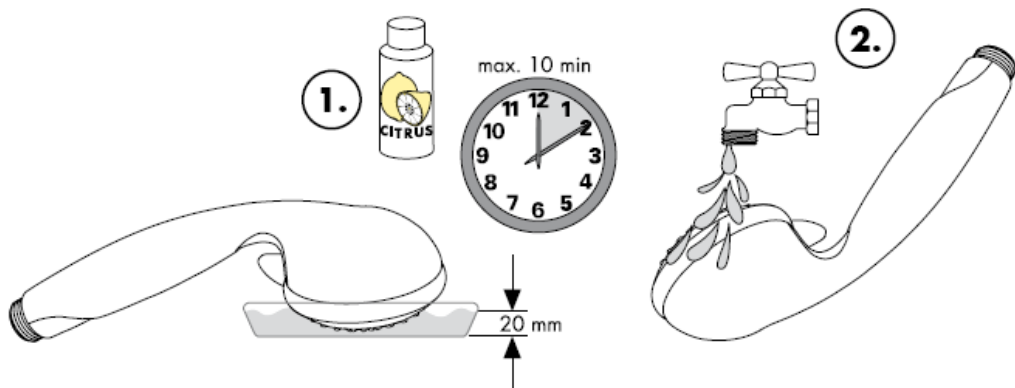

**hansgrohe**

# Montaj kılavuzu



**Unica'B**  
27700XXX



**Unica'B**  
27705XXX

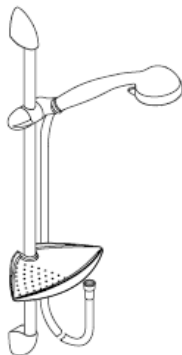

**Selecta/Unica'B**  
27780000/  
27781000



**Selecta 2jet/Unica'B**  
27786000

**hansgrohe**



Mümkün olduğu kadar iyi işlev, yalnız Hansgrohe elle duş parçaları ve Hansgrohe duş boruları kullanılırsa, garanti edilir. Sözü geçen duş boruları, duş parçalarını yalnız donanım takımlarına bağlamaya yarar. Hortumun arkasından sonra akış yönünde kesmek yasaktır!

**Unica'B 27700XXX**

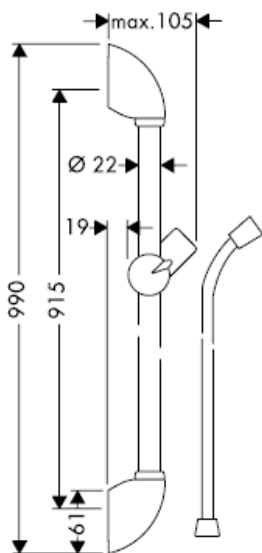

**Unica'B 27705XXX**

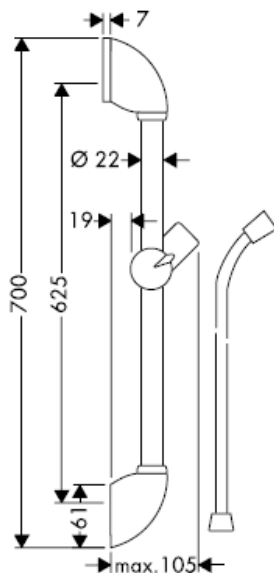

Su püskürtme çubuğu 27824XXX yalnızca ihraç amaçlıdır ve Almanya'da temin edilemez!

**Selecta/Unica'B 27780000**

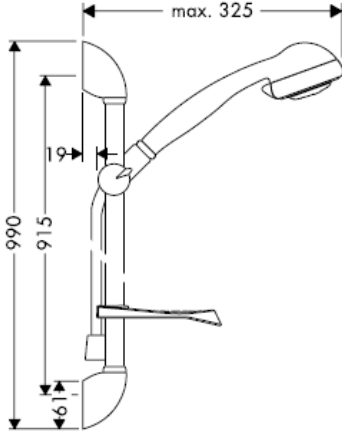

**Selecta/Unica'B 27781000**

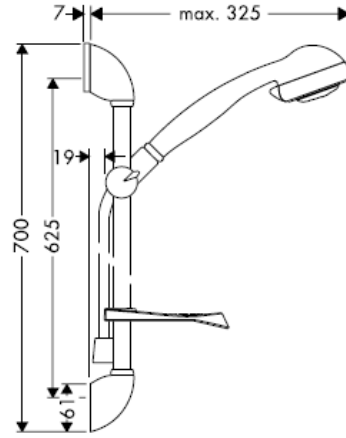

Su püskürtme çubuğu 27824XXX yalnızca ihrac amaçlıdır ve Almanya'da temin edilemez!

**Selecta 2jet/Unica'B 27786000**

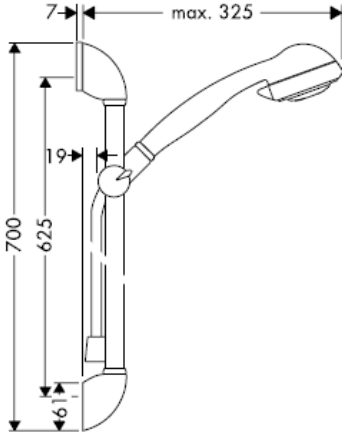

Su püskürtme çubuğu 27824XXX yalnızca ihrac amaçlıdır ve Almanya'da temin edilemez!

## Selecta

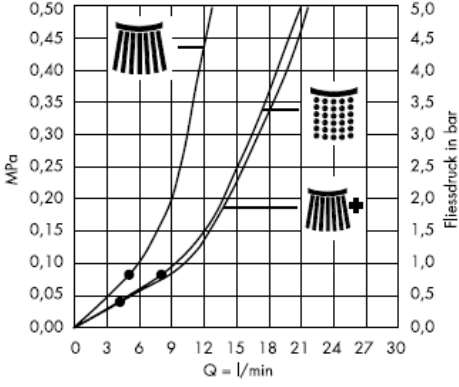

## Selecta 2jet

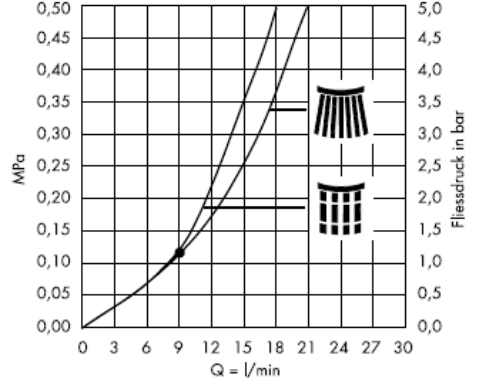

•den itibaren fonksiyon garanti edilmiştir.



Normal duş



Normal su akışı +  
Waterdimmer® (akış  
sınırlayıcı)



Yumuşak



Masaj duşu

## Teknik bilgiler

İşletme basıncı:	max. 0,6 MPa
Tavsiye edilen işletme basıncı: (1 MPa = 10 bar = 147 PSI)	0,1 – 0,4 MPa
Sıcak su sıcaklığı:	max 60°C

Su akış basıncı en azından 0,15 MPa olan yerlerde Hansgrohe tek kollu bataryalarını, hidrolik ve termik kumandalı şofbenlerle birlikte kullanabilirsiniz.

## Kontrol işareti

	DVGW	P-IX	SVGW	ACS	NF	WRAS	KIWA
27700XXX							
27705XXX							
27780000							
27781000				X			
27786000				X			

Müteahhit, ürünü monteleyeceği yer, yani montaj plakasının monte edileceği duvar alanının tümü düz (herhangi bir eklem yerinin ya da duvar fayansının çıkıntısıyla) engellenmemiş, yapısı ürünü montelemeye uygun bir şekilde ve herhangi zayıf noktası olamamasını sağlamalıdır. Kaplı vidalar ve çubuklar sadece beton için uygundur. Başka duvar yapıları için, imalatçının çubuk imal edenin belirttiği hususlar dikkate alınmalıdır.

El duşu kafasına eklenmiş olan süzgeç contası, boru şebekesinden sızan kirlerin önüne geçmek için, yerine monte edilmelidir. İçeri sızan bu kirler duşun fonksiyonunu sekteleyebilir ve/veya duşun fonksiyon parçaları üzerinde hasarlara sebep olabilir, bu yüzden meydana gelen hasarlardan Hansgrohe sorumlu tutulamaz.

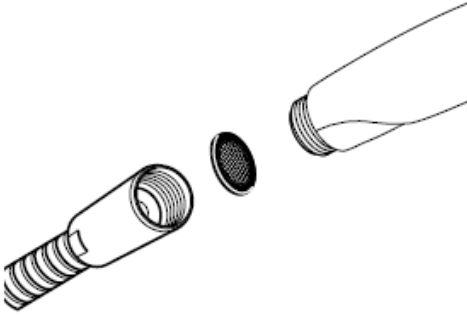

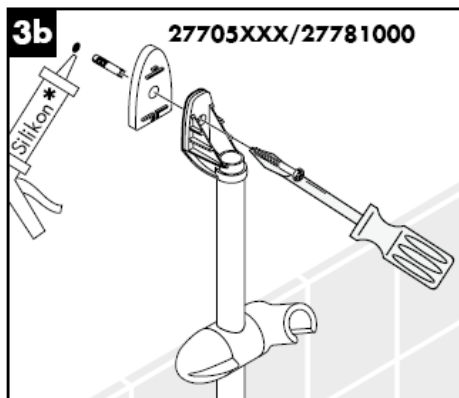
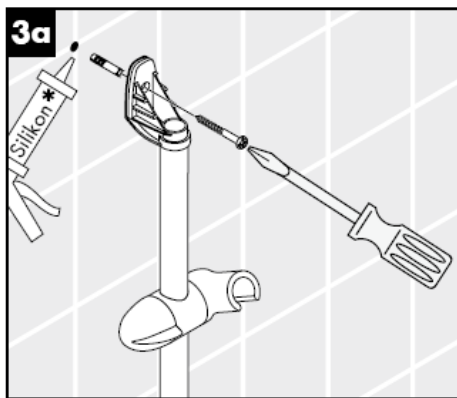
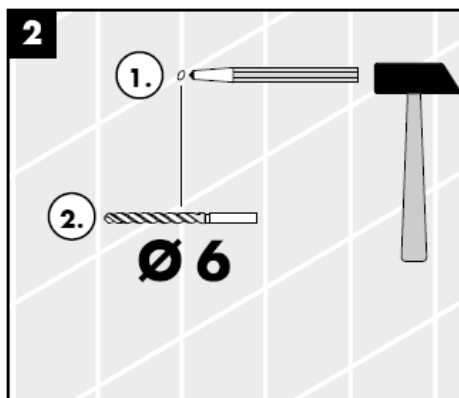
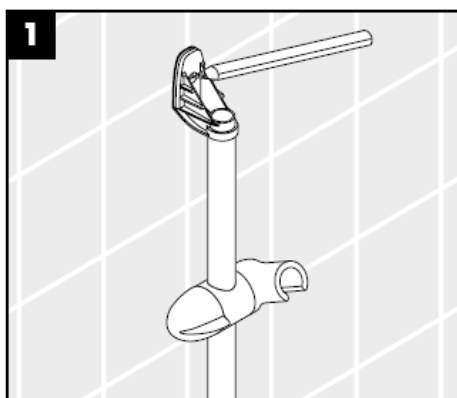

\* Silikon (asetik asit içermeyen)

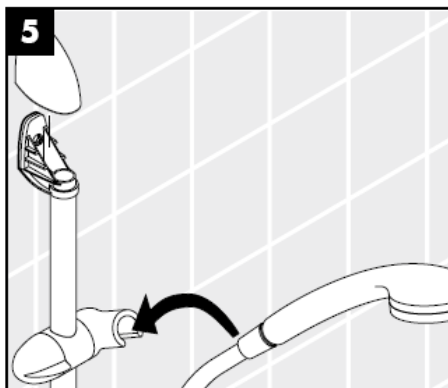
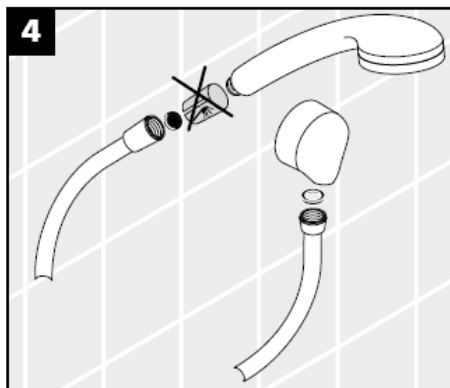

**Cassetta'B** 28686000

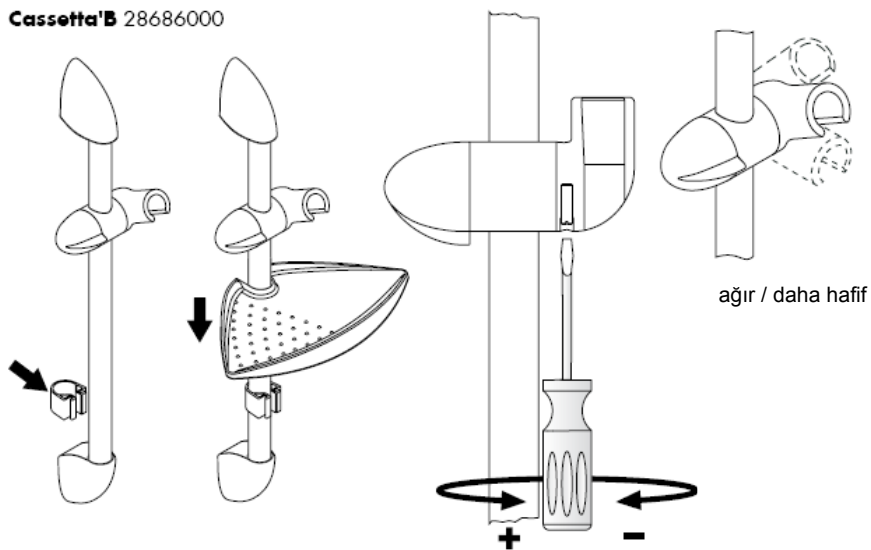

## Temizleme

Rubit®, üründe bulunan bir temizleme fonksiyonudur. Basit bir ovuşturma ile spray modüllerdeki kireci çözer.



## Bakım kılavuzu

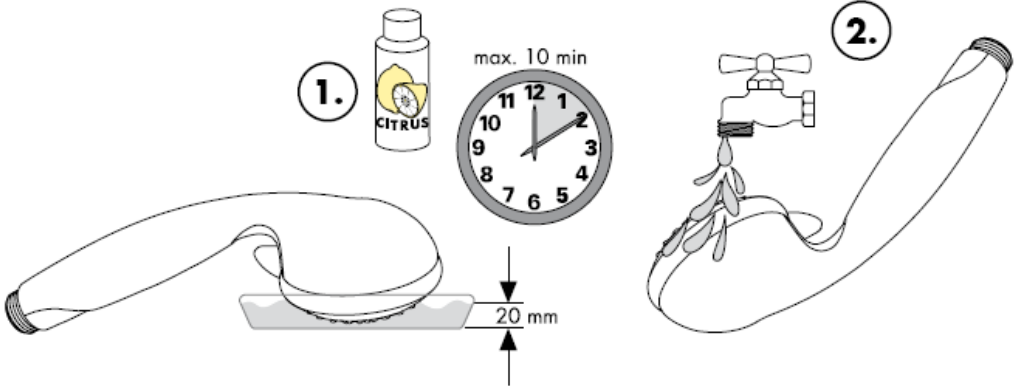

**hansgrohe**

# Instrucțiuni de montare

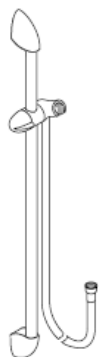

**Unica'B**  
27700XXX



**Unica'B**  
27705XXX

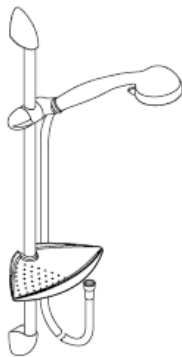

**Selecta/Unica'B**  
27780000/  
27781000



**Selecta 2jet/Unica'B**  
27786000

**hansgrohe**



Funcționarea optimă este garantată numai când ești conectat la duș de mână și furtun de duș marca Hansgrohe. Furtunul de duș poate fi utilizat numai pentru conectarea telefonului de duș la baterie. Nu este permisă montarea unui opritor la capătul furtunului!

**Unica'B 27700XXX**

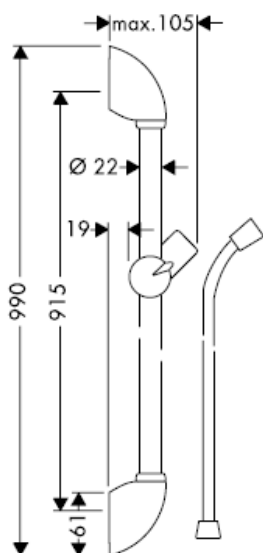

**Unica'B 27705XXX**

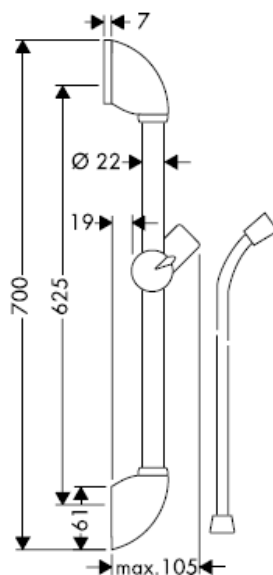

Bara de duș 27814XXX este destinată exclusiv pentru export și nu este disponibilă în Germania!

**Selecta/Unica'B 27780000**

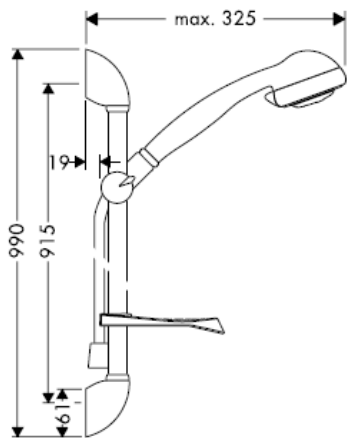

**Selecta/Unica'B 27781000**

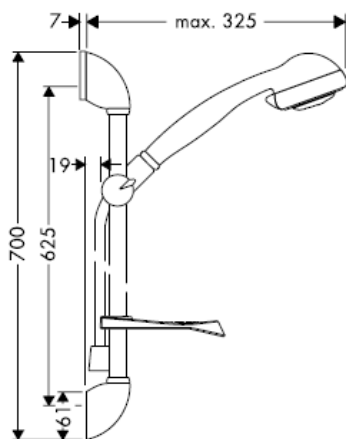

Bara de duș 27814XXX este destinată exclusiv pentru export și nu este disponibilă în Germania!

**Selecta 2jet/Unica'B 27786000**

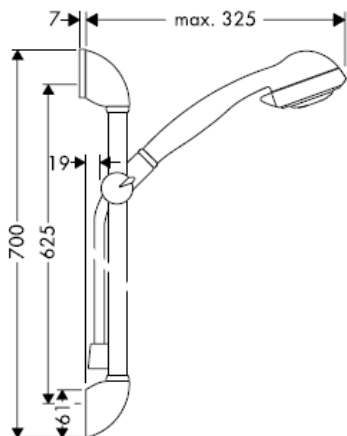

Bara de duș 27814XXX este destinată exclusiv pentru export și nu este disponibilă în Germania!

## Selecta

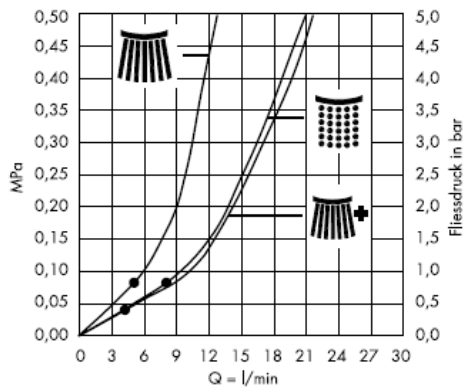

## Selecta 2jet

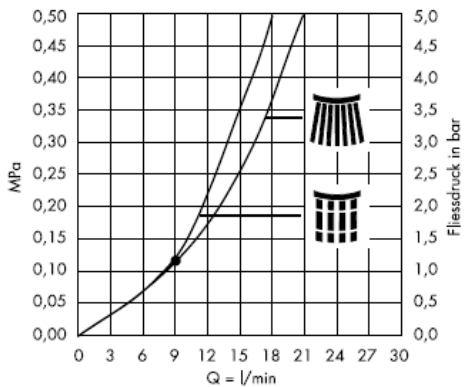

Începând de la • funcționarea este garantată.



jet normal



jet normal +  
Waterdimmer®  
(reductor de debit)



Jet slab de apă



Jet de masaj

## Date tehnice

Presiune de funcționare: max. 0,6 MPa  
Presiune de funcționare recomandată: 0,1 – 0,4 MPa  
(1 MPa = 10 bar = 147 PSI)  
Temperatura apei calde: max 60°C

Bateriile monocomadă Hansgrohe pot fi utilizate cu boiler instant cu comandă termică sau hidraulică dacă presiunea apei de alimentare este de min. 0,15 MPa.

La montarea produsului de către un personal calificat trebuie să fiți atenți ca suprafața, unde se fixează produsul să fie plată pe toată suprafața utilizată (să nu existe rosturi sau faianțe proeminente), peretele să fie adecvat pentru montarea produsului și să nu există zone de rezistență redusă. Șuruburile și diblurile livrate sunt potrivite pentru ziduri de beton. La alte tipuri de zid respectați instrucțiunile producătorului diblului utilizat.

## Certificat de testare

	DVGW	P-IX	SVGW	ACS	NF	WRAS	KIWA
27700XXX							
27705XXX							
27780000							
27781000				X			
27786000				X			

Montați garnitura de filtru livrată împreună cu capătul de duș de mână pentru evitarea pătrunderii impurităților din rețeaua de alimentare. Impuritățile pătrunse pot influența funcționarea aparatului și/sau provoca deteriorarea capătului de duș. Garanția nu acoperă aceste daune.

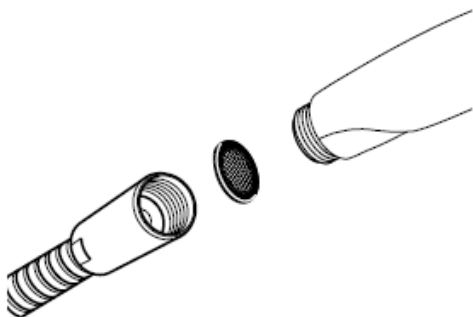

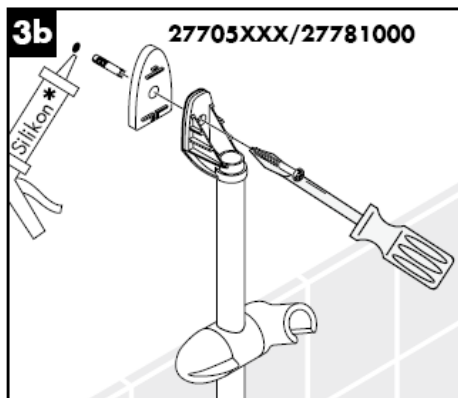
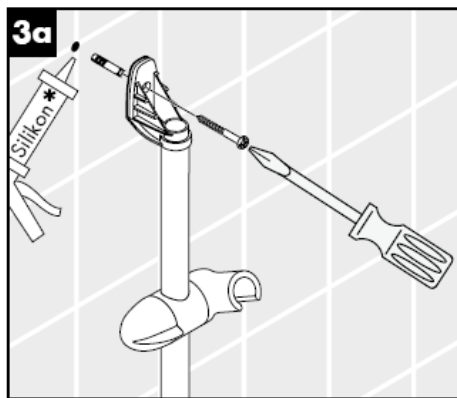
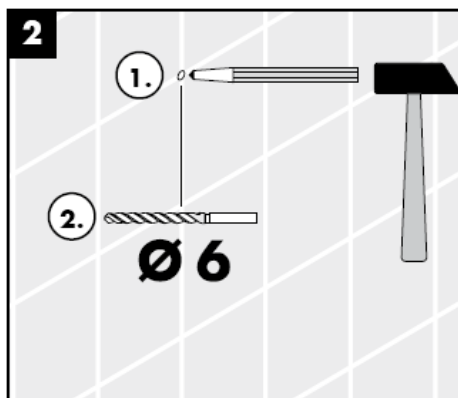
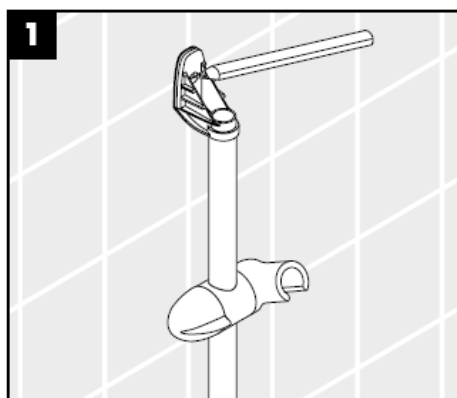

\* Silicon (fără acid acetic!)

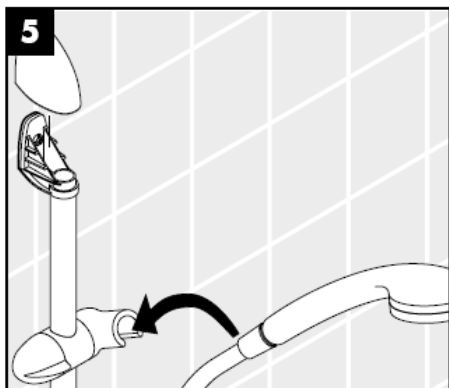
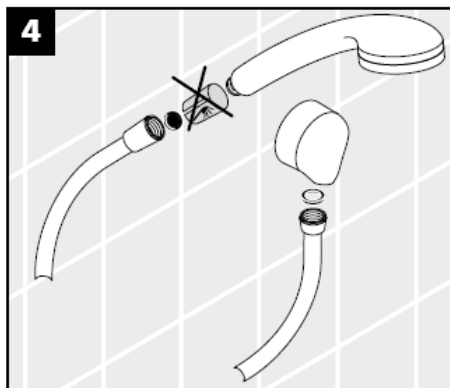

**Cassetta'B** 28686000

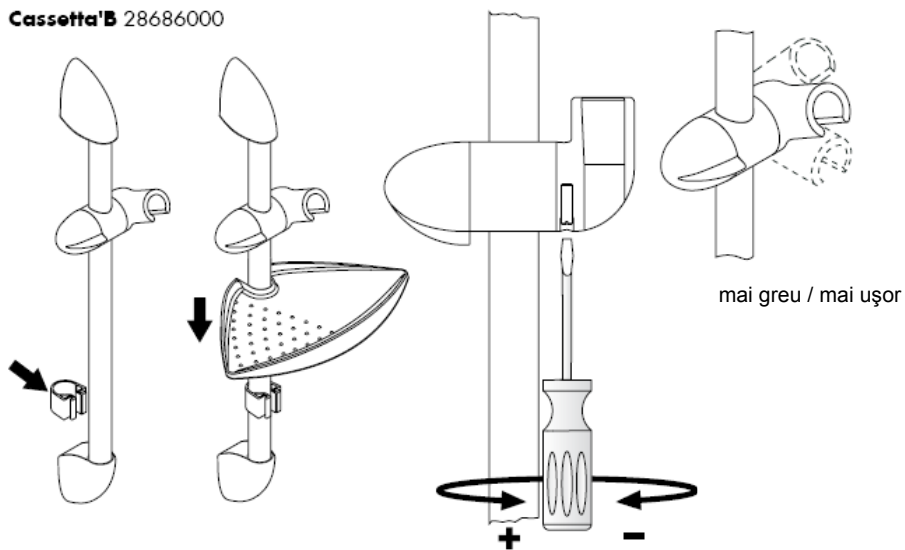

## Curățare

Cu ajutorul sistemului Rubit® puteți să îndepărtați depunerile de calcar de pe diferitele duze de jet de apă prin frecare.

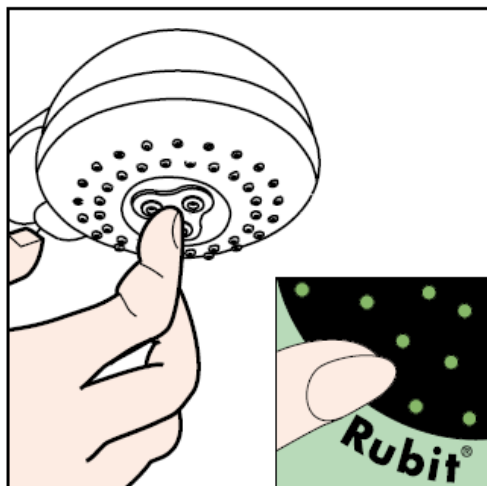

## Instrucțiuni de întreținere

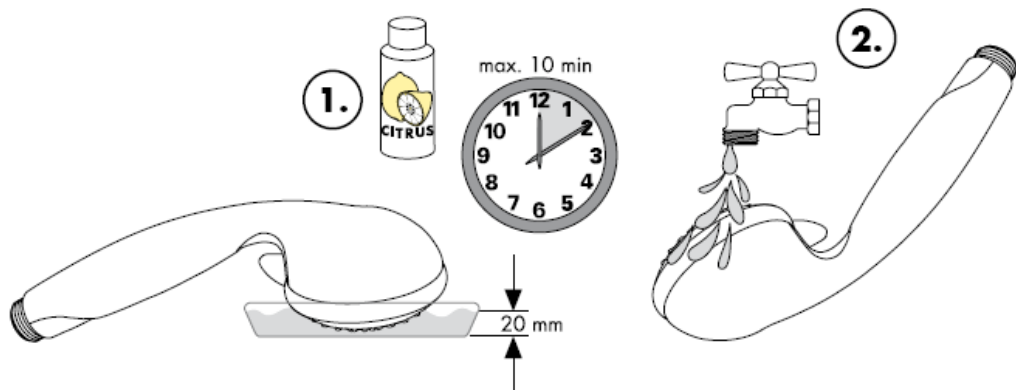

**hansgrohe**

# Οδηγία συναρμολόγησης

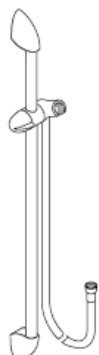

**Unica'B**  
27700XXX



**Unica'B**  
27705XXX

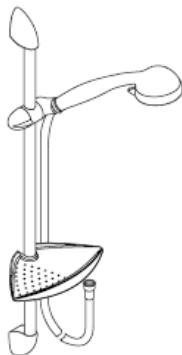

**Selecta/Unica'B**  
27780000/  
27781000



**Selecta 2jet/Unica'B**  
27786000

**hansgrohe**



Εγγύηση βέλτιστης λειτουργίας μόνο σε συνδυασμό με καταιονιστήρα χειρός Hansgrohe και σπιράλ Hansgrohe. Το εύκαμπτο σπιράλ του καταιονιστήρα είναι κατάλληλο μόνο για τη σύνδεση του καταιονιστήρα χειρός με τη βάνα. Δεν επιτρέπεται καμία στρόφιγγα διακοπής μετά το σωλήνα στην κατεύθυνση ροής!

**Unica'B 27700XXX**

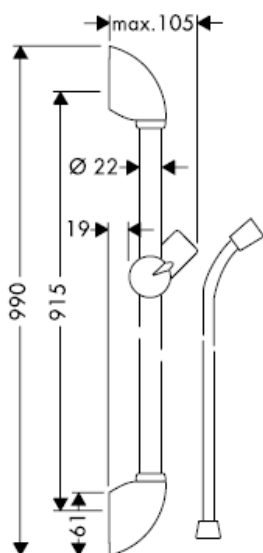

**Unica'B 27705XXX**

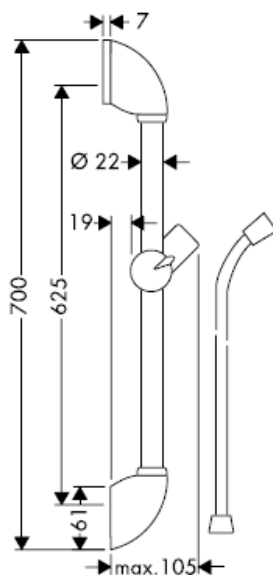

Η βέργα του ντους 27824XXX είναι μόνο για χώρες του εξωτερικού και δεν πωλείται στη Γερμανία!

**Selecta/Unica'B 27780000**

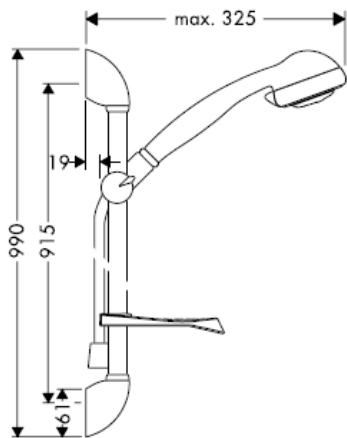

**Selecta/Unica'B 27781000**

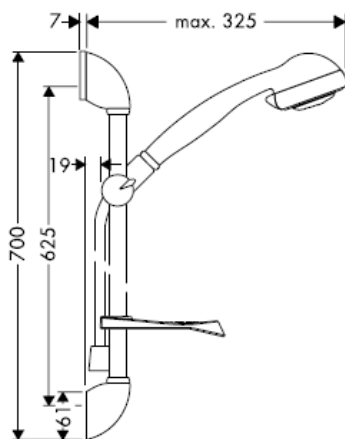

Η βέργα του ντους 27824XXX είναι μόνο για χώρες του εξωτερικού και δεν πωλείται στη Γερμανία!

**Selecta 2jet/Unica'B 27786000**

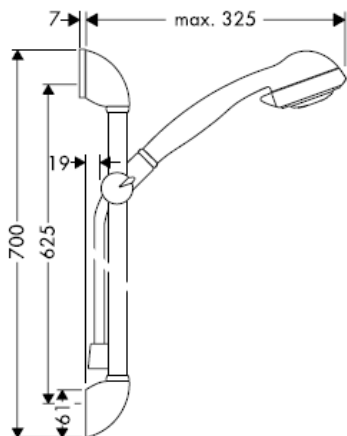

Η βέργα του ντους 27824XXX είναι μόνο για χώρες του εξωτερικού και δεν πωλείται στη Γερμανία!

## Selecta

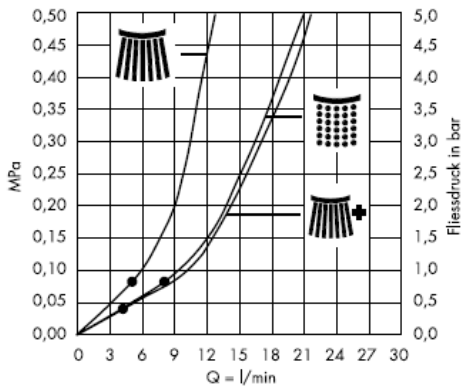

## Selecta 2jet

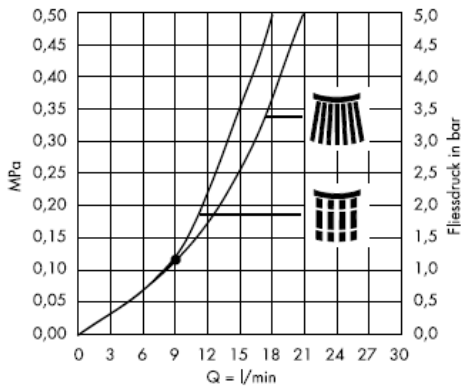

Αυτή η λειτουργία διασφαλίζεται από το σημείο κι έπειτα



Κανονική δέσμη νερού



Κανονική δέσμη νερού + ελαχιστοποιητής νερού (Waterdimmer®) (περιοριστική διάταξη ροής)



μαλακή δέσμη νερού



Δέσμη υδρομασάζ

## Τεχνικά Χαρακτηριστικά

Λειτουργία πίεσης: max. 0,6 MPa  
Συνιστώμενη λειτουργία πίεσης: 0,1 – 0,4 MPa  
(1 MPa = 10 bar = 147 PSI)  
Θερμοκρασία ζεστού νερού: max 60°C

Οι αναμεικτικές μπαταρίες Hansgrohe μπορούν να λειτουργούν και σε συνδυασμό με ταχυθερμοσίφωνες θερμικού ή υδραυλικού ελέγχου, εφόσον η ελάχιστη πίεση ροής είναι 0,15 MPa.

Κατά τη συναρμολόγηση του προϊόντος από καταρτισμένο και εξειδικευμένο προσωπικό θα πρέπει να δοθεί προσοχή, ώστε η επιφάνεια στερέωσης στη συνολική περιοχή στερέωσης να είναι επίπεδη (να μην υπάρχουν προεξέχοντες αρμοί ή λιθογόμωση πλακιδίων), ώστε η κατασκευή του τοίχου να είναι κατάλληλη για τη συναρμολόγηση του προϊόντος και ώστε η επιφάνεια να μην παρουσιάζει αδύναμα σημεία.

Οι συνημμένες βίδες και οι στυλίσκοι ενδείκνυται μόνο για σκυρόδεμα. Σε άλλες επίτοιχες κατασκευές θα πρέπει να δοθεί προσοχή στα δεδομένα του Κατασκευαστή των στυλίσκων.

## Σήμα ελέγχου

	DVGW	P-IX	SVGW	ACS	NF	WRAS	KIWA
27700XXX							
27705XXX							
27780000							
27781000				X			
27786000				X			

Πρέπει να εγκατασταθεί το παρέμβυσμα φίλτρου που συνοδεύει τον καταιονιστήρα κατά τέτοιο τρόπο, ώστε να αποφεύγονται ρύποι που προέρχονται από το δίκτυο ύδρευσης. Οι ρύποι από το δίκτυο ύδρευσης μπορούν να επηρεάσουν αρνητικά και/ ή να προξενήσουν ζημία στα λειτουργικά τμήματα του καταιονιστήρα (ντους). Τέτοιου είδους ζημιές δεν καλύπτονται από την εγγύηση Hansgrohe.

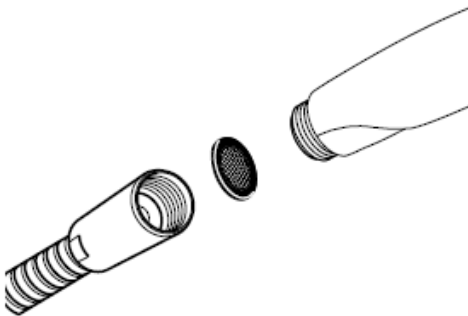

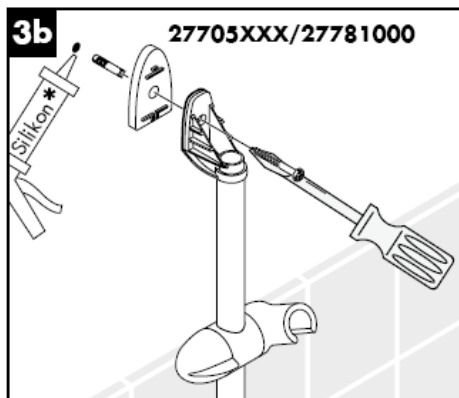
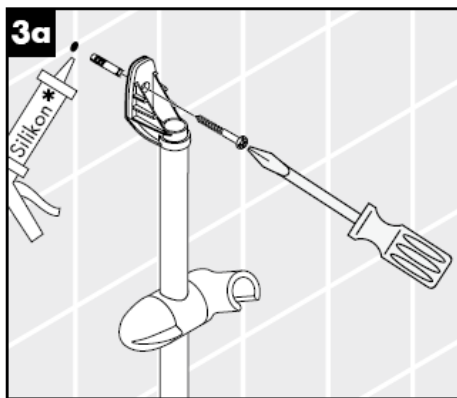
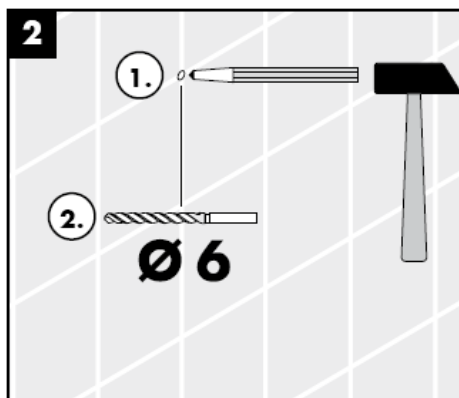
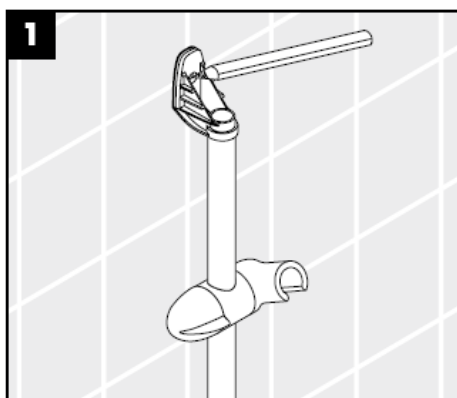

\* Σιλικόνη (δίχως οξικό οξύ!)

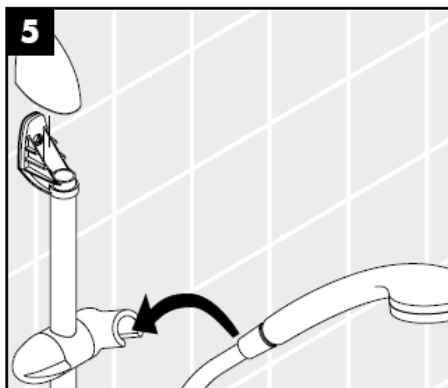
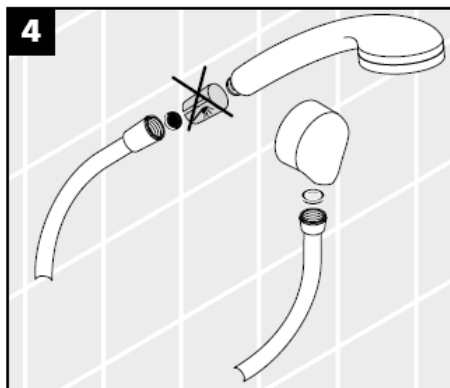

**Cassetta'B** 28686000

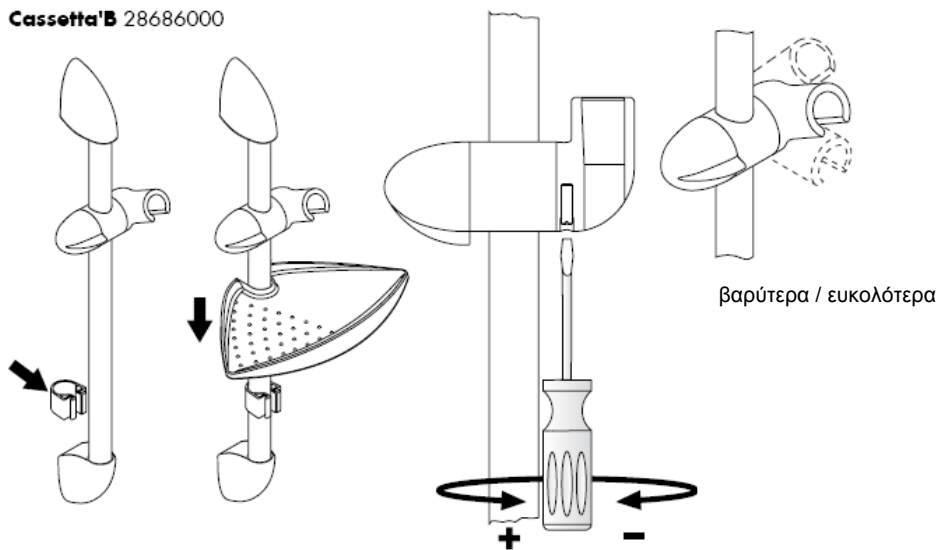

## Καθαρισμός

Με Rubit®, τη λειτουργία καθαρισμού με το χέρι, μπορούν να απομακρυνθούν με απλό τρίψιμο τα άλατα από τα κανάλια του καταιονιστήρα.

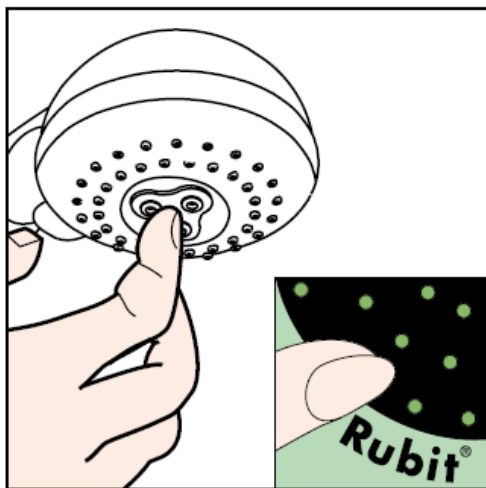

## Οδηγία συντήρησης

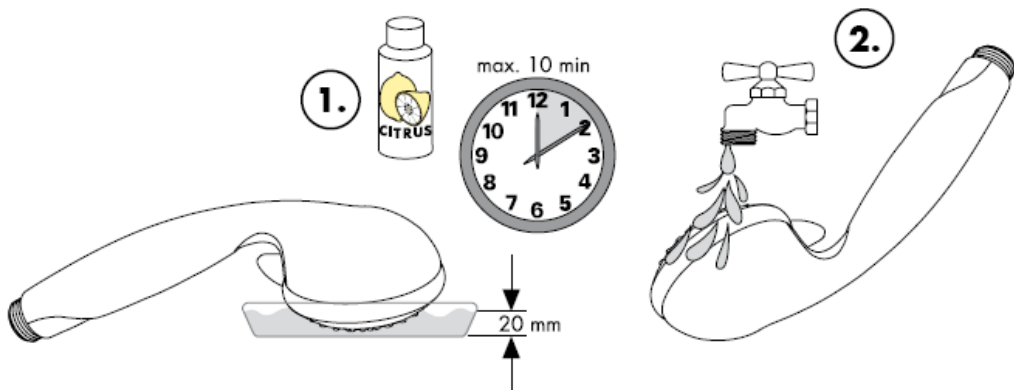

**hansgrohe**

# تعليمات التجميع

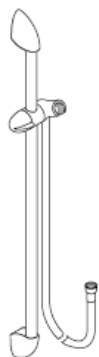

**Unica'B**  
27700XXX



**Unica'B**  
27705XXX

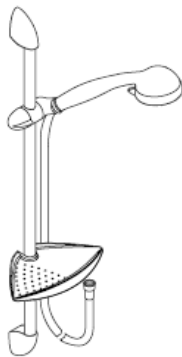

**Selecta/Unica'B**  
27780000/  
27781000



**Selecta 2jet/Unica'B**  
27786000

**hansgrohe**



لا يمكن ضمان الحصول على الأداء الأمثل إلا من خلال الجمع بين الدش اليدوي إنتاج هانزجروره وخراطيم الدش إنتاج هانزجروره. لا تصلح خراطيم الدش إلا للتوصيل من الدش إلى الوصلة. حذار من تركيب جهاز إغلاق بين الوصلة والخرطوم.

**Unica'B 27700XXX**

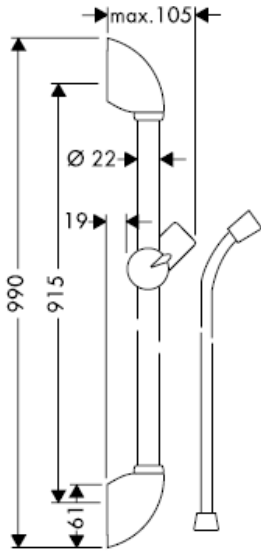

**Unica'B 27705XXX**

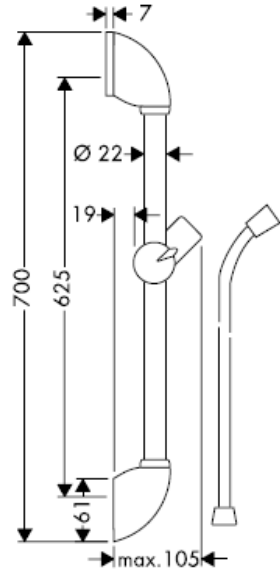

مسطرة المنتج رقم XXX27824 مخصصة للتصدير فقط لذا فهي غير متوفرة في ألمانيا.

**Selecta/Unica'B 27780000**

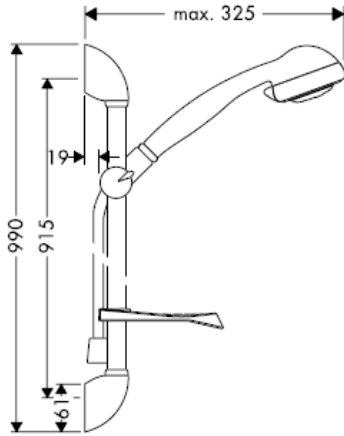

**Selecta/Unica'B 27781000**

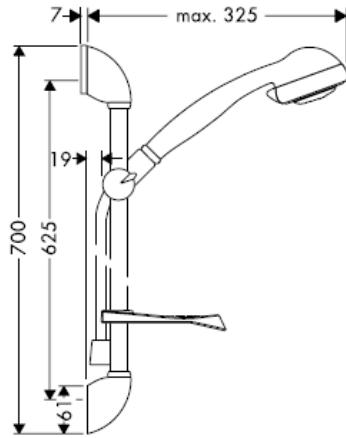

مسطرة المنتج رقم XXX27824 مخصصة للتصدير فقط لذا فهي غير متوفرة في ألمانيا.

**Selecta 2jet/Unica'B 27786000**

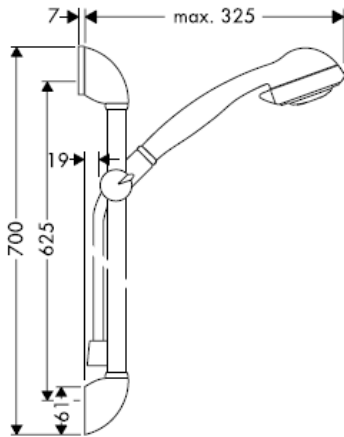

مسطرة المنتج رقم XXX27824 مخصصة للتصدير فقط لذا فهي غير متوفرة في ألمانيا.

## Selecta

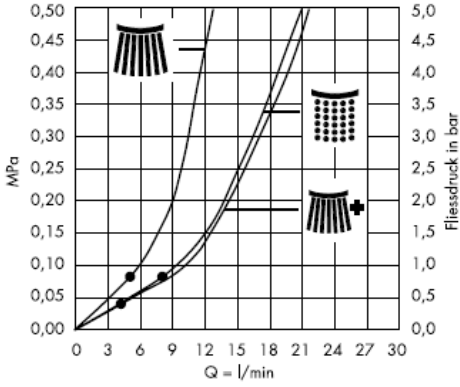

## Selecta 2jet

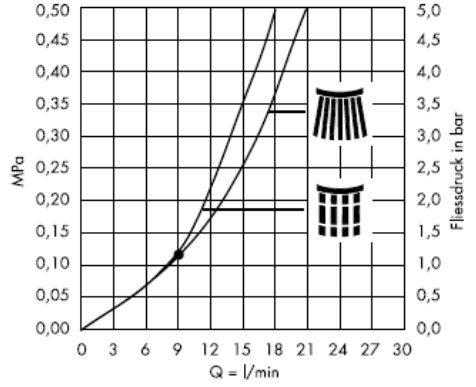

من • الوظيفة مضمونة.



رشاش عادي



رشاش عادي + محدد التدفق  
Waterdimmer®



رشاش مرن



تيار التدليك

المواصفات الفنية

يجب الانتباه عند تركيب المنتج بواسطة فريق العمل المتخصص إلى أن جميع مواضع التثبيت جاهزة للتثبيت دون عوائق (خالية من المفصلات أو المصقات)، وأن الحائط جاهز لتركيب المنتج مع عدم احتوائه على أية أماكن ضعيفة. مبيّات المسامير (الفيشر) والمسامير نفسها مناسبة للحوائط الخرسانية فقط، ويجب الالتزام بتعليمات الجهة المصنعة لمبيّات المسامير عند التثبيت في أنواع أخرى من الحوائط.

max. 0,6 MPa

0,1 – 0,4 MPa

max 60°C

ضغط التشغيل:

ضغط التشغيل الموصى به:

( 1 MPa = 147 PSI = 10 بار )

درجة حرارة الماء الساخن:

يمكن استخدام خلطات هانز جروهه أحادية المقبض مع سخانات تدفّق الماء ذات التحكم الهيدروليكي أو الحراري، مع ضغط تدفّق لا يقل عن 1.5 بار.

شهادة اختبار

	DVGW	P-IX	SVGW	ACS	NF	WRAS	KIWA
27700XXX							
27705XXX							
27780000							
27781000				X			
27786000				X			

يجب إدخال الحلقة الشبكية لحماية الدش البدوي من الأوساخ التي تحملها شبكة المواسير. حيث تؤدي الأوساخ الواردة إلى حدوث أعطال أو / و قد تتسبب في تلف أجزاء من من الدش، ومثل هذه الأعطال تلغي كافة المطالبات الخاصة بالمسؤولية أو الضمان.

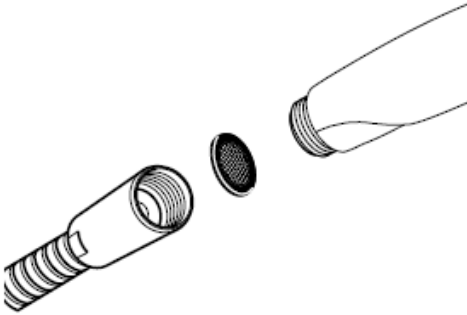

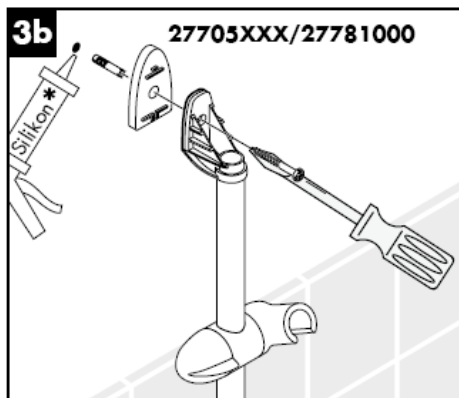
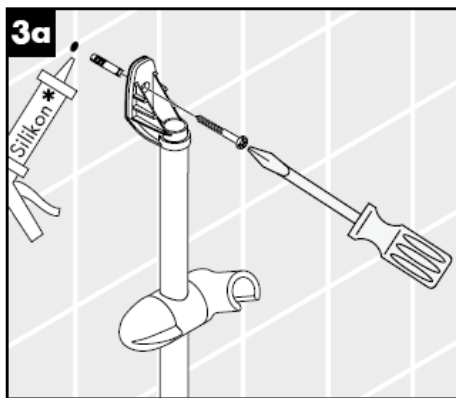
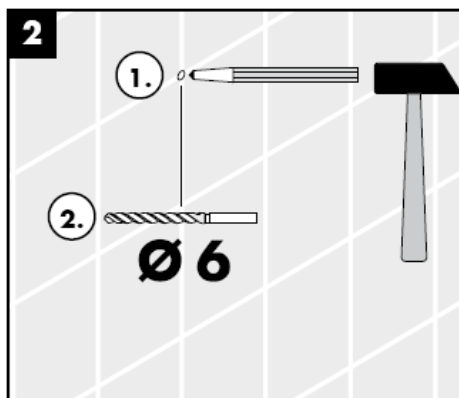
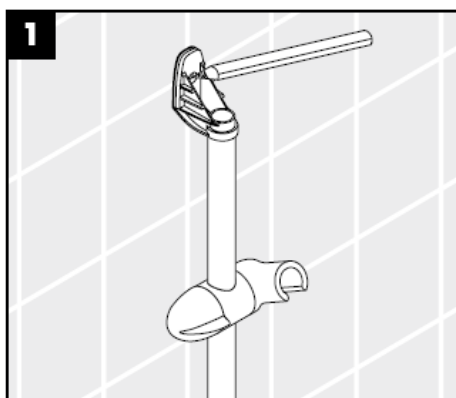

\* سيليكون (خالي من حمض الخليك!)

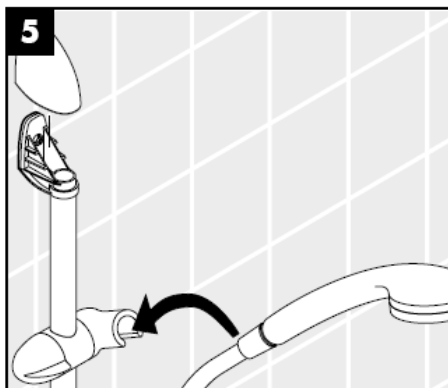
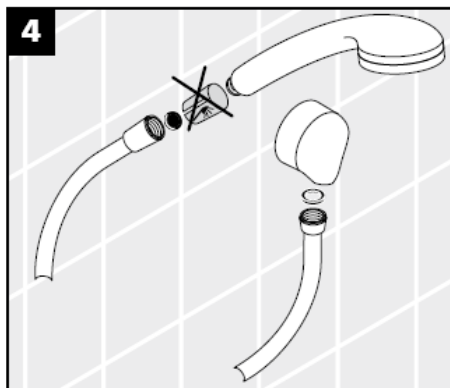

**Cassetta'B** 28686000

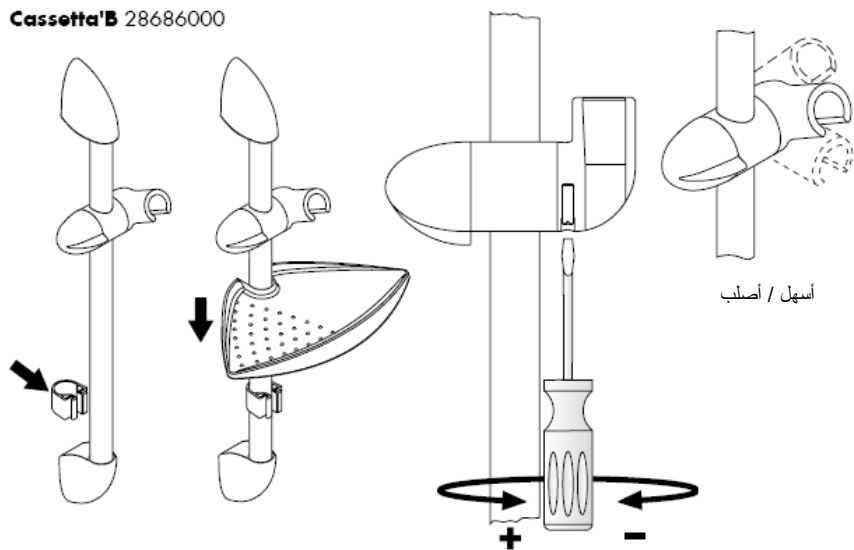

لا تحتاج وظيفة تنظيف سوى قدر بسيط من الفرك باليد لإزالة القشور الجيرية من قنوات الرشاش.

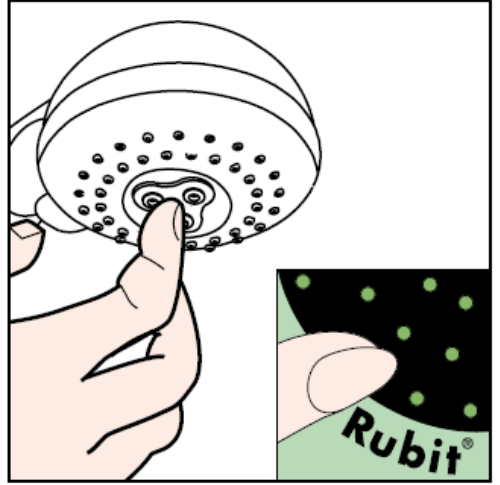

تعليمات التنظيف

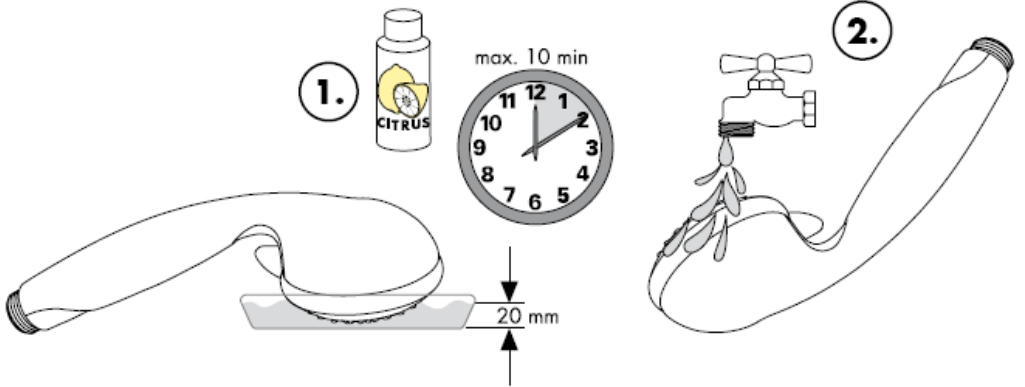

**hansgrohe**

# Navodila za montažo



**Unica'B**  
27700XXX



**Unica'B**  
27705XXX

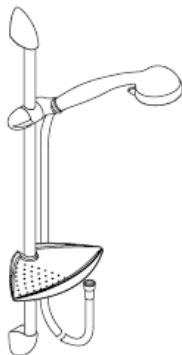

**Selecta/Unica'B**  
27780000/  
27781000



**Selecta 2jet/Unica'B**  
27786000

**hansgrohe**



Optimalno delovanje je zagotovljeno le v povezavi z ročnimi prhami Hansgrohe in gibkimi cevmi za prho Hansgrohe. Gibke cevi za prho so primerne le za povezavo prhe in armature. Naprave za zapiranje pretoka vode nikoli ne nameščajte med armaturo in cev.

**Unica'B 27700XXX**

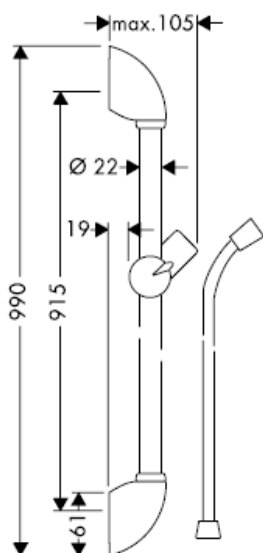

**Unica'B 27705XXX**

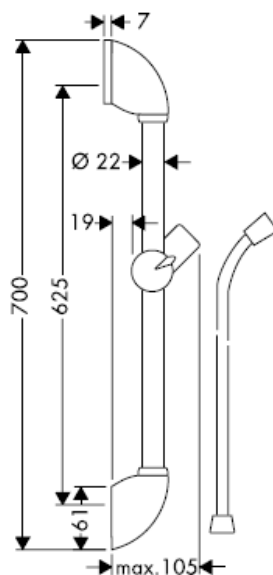

Nosilec prhe 27824XXX je namenjen izključno za izvoz in zato v Nemčiji ni dobavljiv!

**Selecta/Unica'B 27780000**

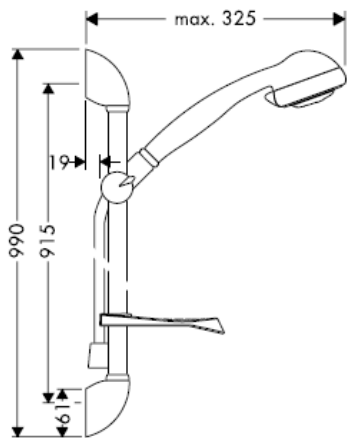

**Selecta/Unica'B 27781000**

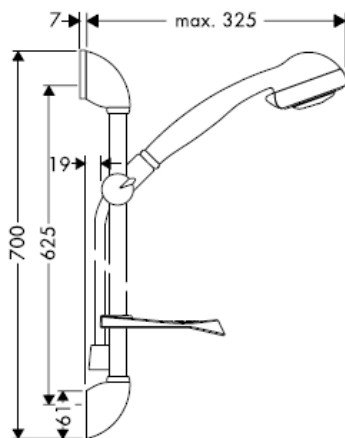

La barre de douche 27824XXX étant exclusivement destinée à l'export, elle n'est pas livrée en

**Selecta 2jet/Unica'B 27786000**

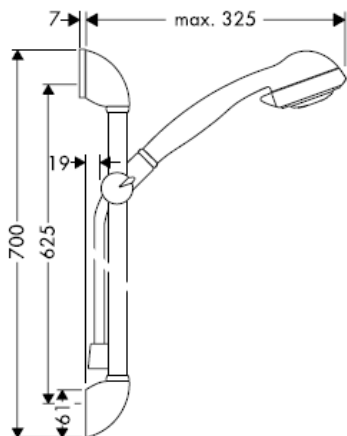

Nosilec prhe 27824XXX je namenjen izključno za izvoz in zato v Nemčiji ni dobavljiv!

## Selecta

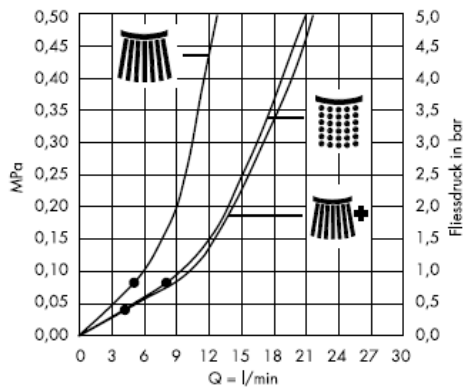

## Selecta 2jet

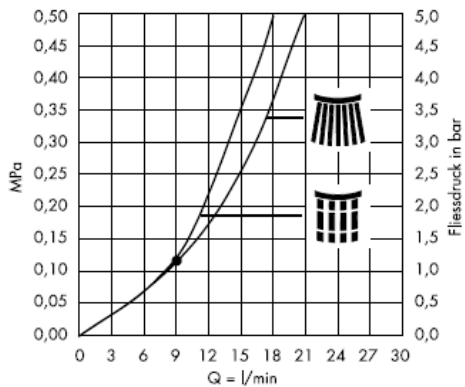

Od • je delovanje zagotovljeno.



Normalen curek



Normalen curek +  
waterdimmer®  
(omejevalnik pretoka  
vode)



Mehki curek



Masažni curek

## Tehnični podatki

Delovni tlak:	max. 0,6 MPa
Priporočeni delovni tlak: (1 MPa = 10 bar = 147 PSI)	0,1 – 0,4 MPa
Temperatura tople vode:	max 60°C

Enoročne mešalne baterije Hansgrohe lahko uporabljate v povezavi s hidravlično in termično uravnavanimi pretočnimi grelniki, če je pretočni tlak najmanj 0,15 MPa.

## Preskusni znak

	DVGW	P-IX	SVGW	ACS	NF	WRAS	KIWA
27700XXX							
27705XXX							
27780000							
27781000				X			
27786000				X			

Filter, ki je priložen ročni prhi, je potrebno vgraditi, da prho zaščitimo pred umazanijo iz vodovodne napeljave. Umazanija lahko okvari ali poškoduje dele ročne prhe. Za tako nastalo škodo Hansgrohe ne odgovarja.

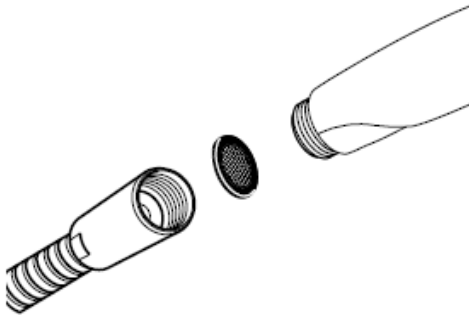

Kamorkoli bo pogodbenik namestil izdelek, mora poskrbeti, da je celotno območje stene na katero bo plošča nameščena ravno (brez štrlečih fug ali robov ploščic), ter da je struktura stene primerna za namestitev in je brez šibkih točk.

Priloženi vijaki in ležaji so primerni le za beton. Za ostale zidne konstrukcije je potrebno upoštevati proizvajalčeva navodila.

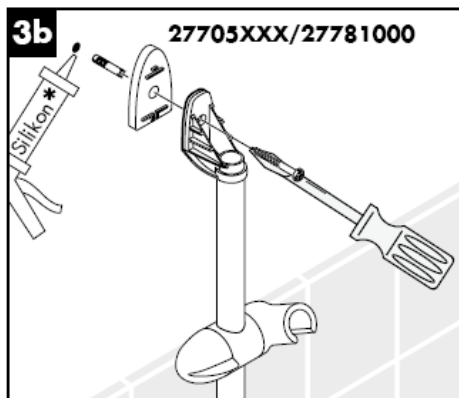
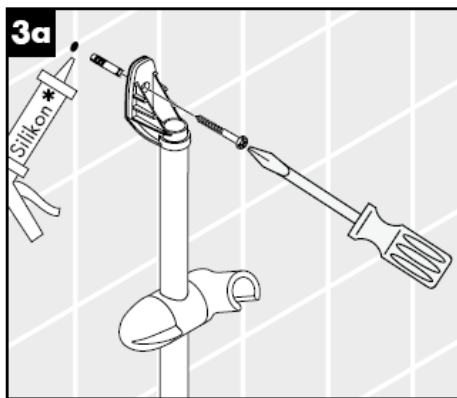
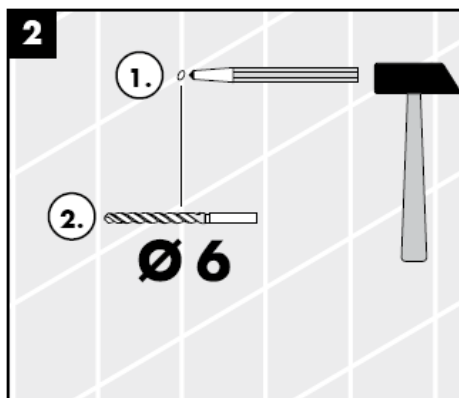
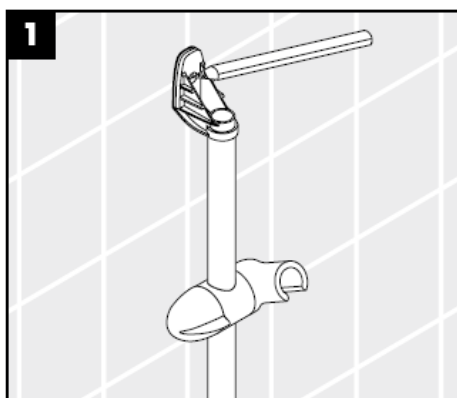

\* Silikon (brez očetne kisline)

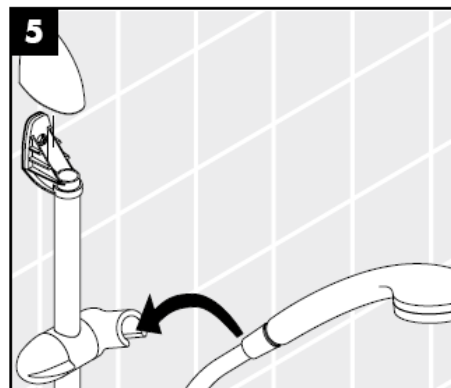
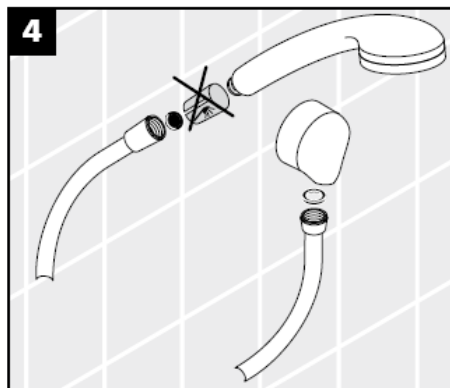

**Cassetta'B** 28686000

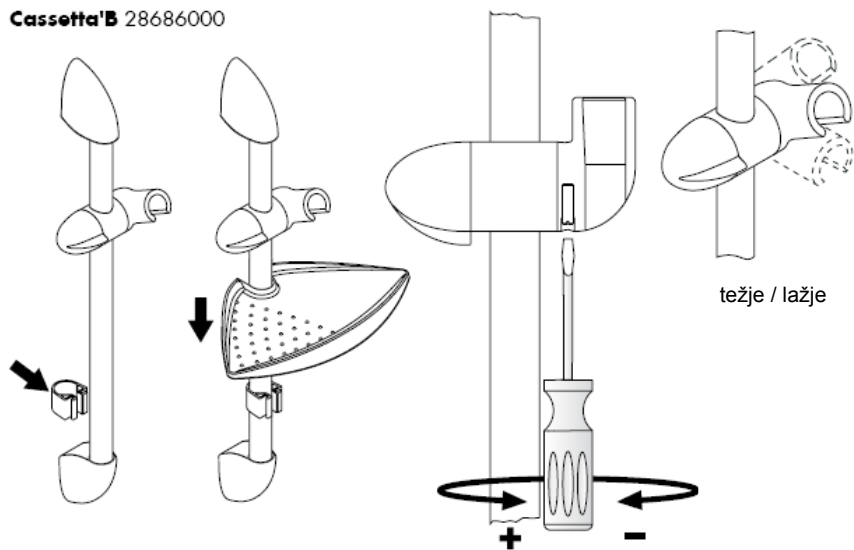

## Čiščenje

Z Rubit®, ročno čistilno funkcijo, lahko s šob očistimo vodni kamen tako, da šobe enostavno podrgnemo.



### Navodila za nego

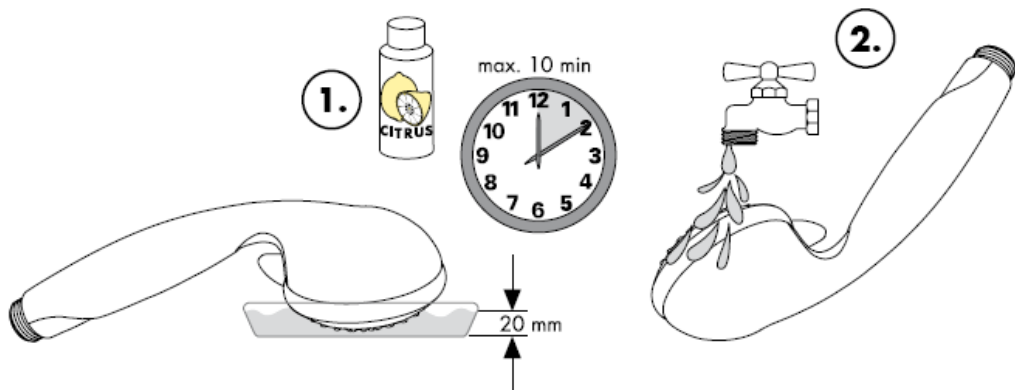

**hansgrohe**

# Paigaldusjuhend



**Unica'B**  
27700XXX



**Unica'B**  
27705XXX

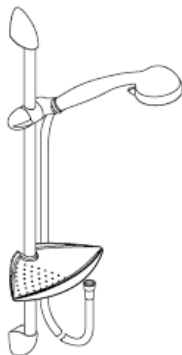

**Selecta/Unica'B**  
27780000/  
27781000



**Selecta 2jet/Unica'B**  
27786000

**hansgrohe**



Optimaalne funktsioneerimine on garanteeritud ainult koos Hansgrohe käsiduššide ja Hansgrohe dušivoolikutega. Dušivoolikud sobivad üksnes duši ühendamiseks segistitega. Mingil juhul ei tohi vooliku ja segisti vahele asetada sulgurit.

**Unica'B 27700XXX**

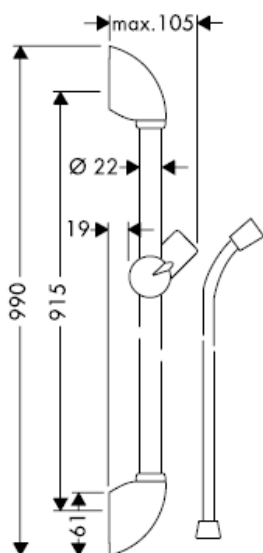

**Unica'B 27705XXX**

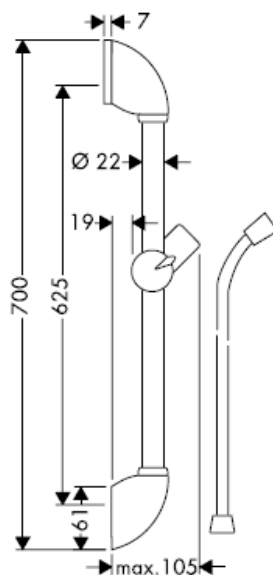

Dušilift 27824XXX on ainult ekspordiks ja seepärast pole seda Saksamaal saada!

**Selecta/Unica'B 27780000**

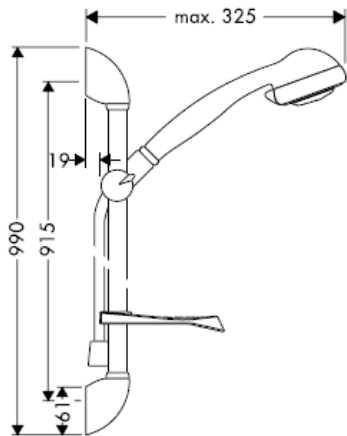

**Selecta/Unica'B 27781000**

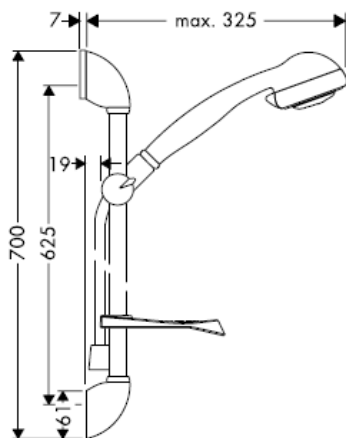

Dušilift 27824XXX on ainult ekspordiks ja seepärast pole seda Saksamaal saada!

**Selecta 2jet/Unica'B 27786000**

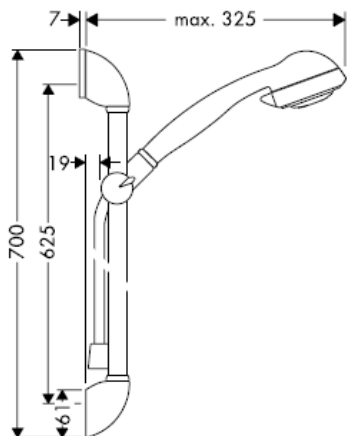

Dušilift 27824XXX on ainult ekspordiks ja seepärast pole seda Saksamaal saada!

## Selecta

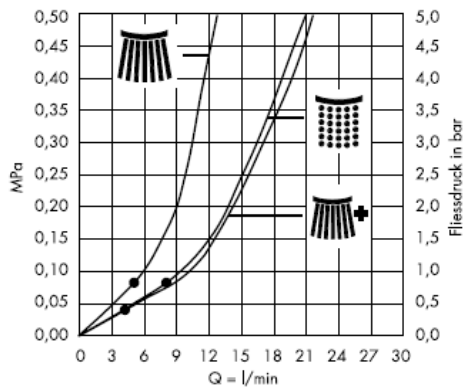

## Selecta 2jet

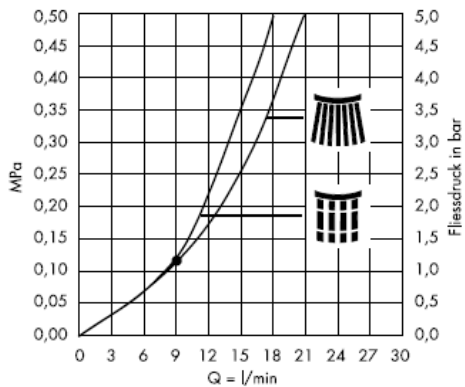

Alates • on funktsioneerimine garanteeritud



tavajuga



Tavajuga +  
Waterdimmer®  
(lābivoolu piiraja)



Pehme juga



Massaažipihusti

## Tehnilised andmed

Töörõhk	max. 0,6 MPa
Soovitatav töörõhk: (1 MPa = 10 baari = 147 PSI)	0,1 – 0,4 MPa
Kuuma vee temperatuur:	max 60°C

Hansgrohe ühekäe segisteid võib kasutada koos hüdrauliselt ja termiliselt juhitavate boileritega, kui vee rõhk on vähemalt 0,15 MPa.

Toote paigaldamisel peab töövõtja tagama, et kogu seinapind, kuhu paigaldusplaat kinnitatakse, on lame (ükski vuuk ega keraamiline plaat ei ulatu esile), ning et seina konstruktsioon on toote paigaldamiseks sobiv ja sellele puuduvad nõrgad kohad. Kaasasolevad kruvid ja tüüblid sobivad üksnes betoonile. Muude seinakonstruktsioonide puhul tuleb arvesse võtta tüüblitootja esitatud tooteandmeid.

## Kontrollsertifikaat

	DVGW	P-IX	SVGW	ACS	NF	WRAS	KIWA
27700XXX							
27705XXX							
27780000							
27781000				X			
27786000				X			

Kaitsmaks duši torust tuleva mustuse eest, on vaja paigaldada dušiga kaasasolev mustusesõel. Sissetulev mustus võib funktsioneerimist kahjustada ja/või rikkuda duši detaile. Sellest tulenevate kahjude eest Hansgrohe ei vastuta.

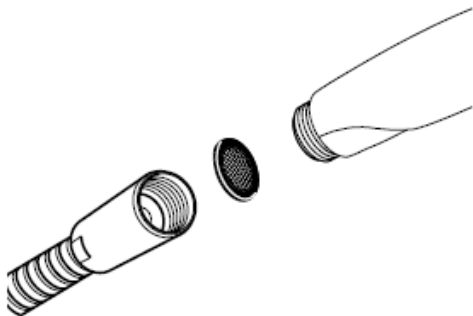

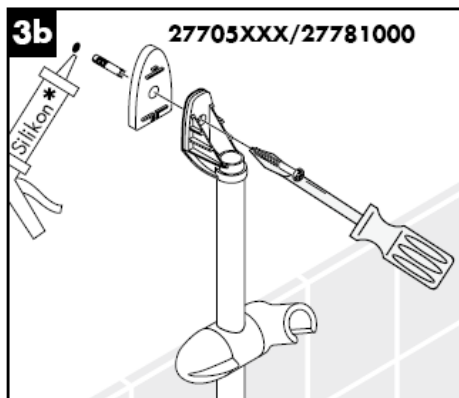
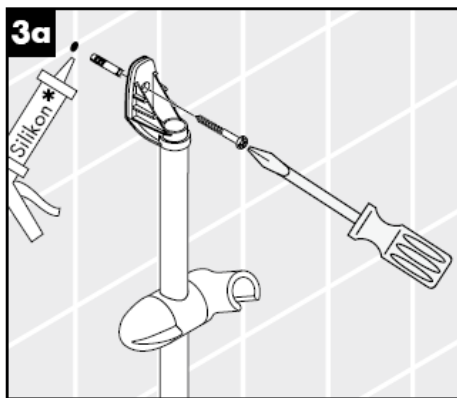
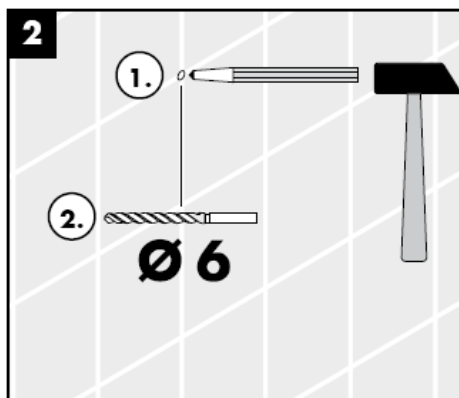
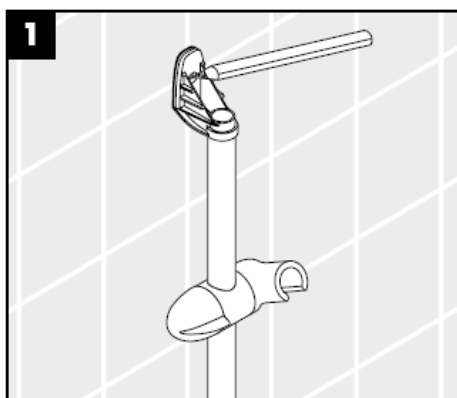

\* Siilikon (äädikhappeta!)

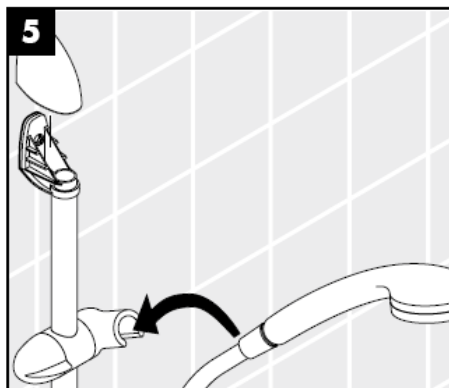
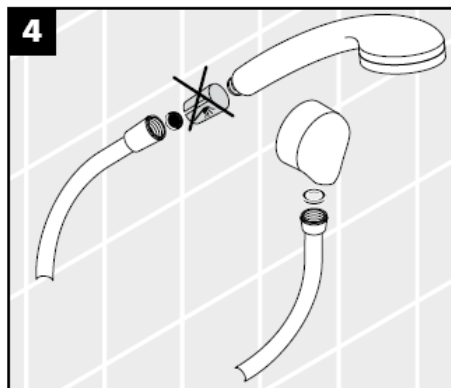

**Cassetta'B** 28686000

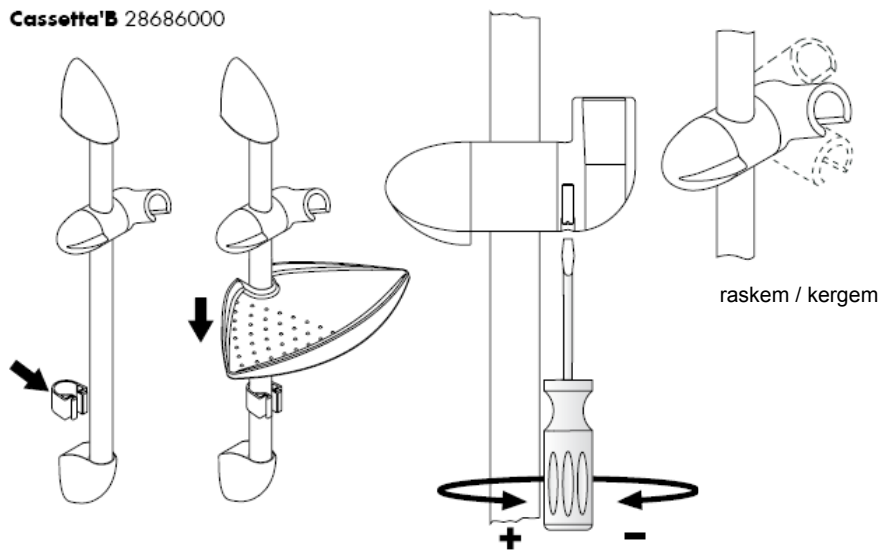

## Puhastamine

Käsitsi puhastamise funktsiooni Rubit® puhul on vajalik vaid kerge ülehõõrumine, eemaldamaks dušikanalitest katlakivi.



## Hooldusjuhend

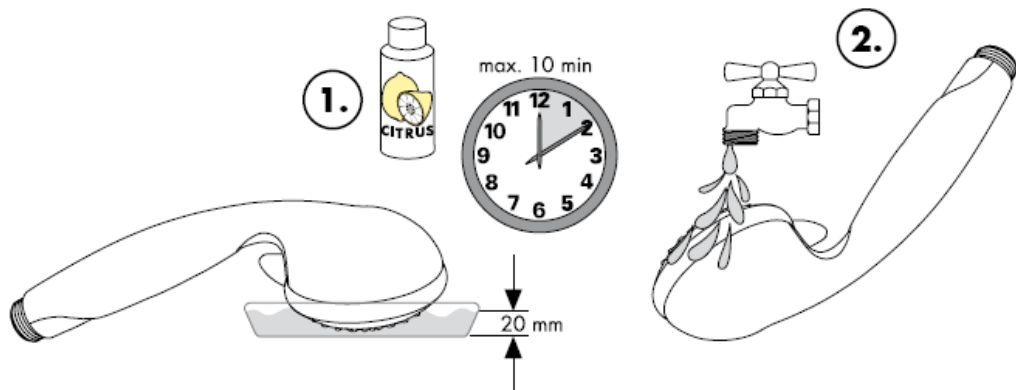

**hansgrohe**

# Montāžas instrukcija

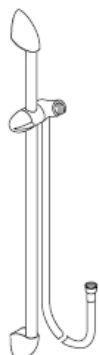

**Unica'B**  
27700XXX



**Unica'B**  
27705XXX



**Selecta/Unica'B**  
27780000/  
27781000



**Selecta 2jet/Unica'B**  
27786000

**hansgrohe**



Optimāla funkcija tiek garantēta tikai kombinācijā ar Hansgrohe rokas dušām un Hansgrohe dušas šļūtenēm. Dušas šļūtenes ir piemērotas tikai dušas pieslēgšanai pie jaucējkrāna. Nepieļaujama ir noslēgarmatūras pievienošana aiz šļūtenes plūsmas virzienā!

**Unica'B 27700XXX**

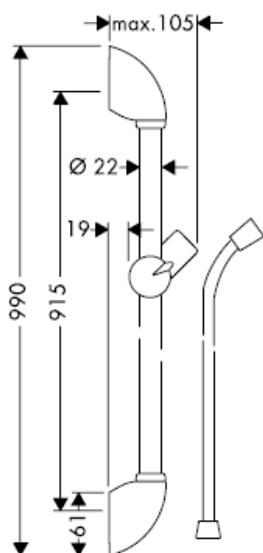

**Unica'B 27705XXX**

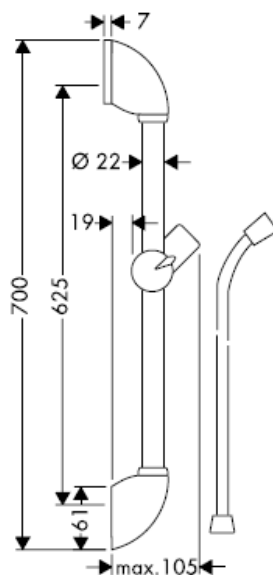

Dušas stienis 27824XXX ir paredzēts tikai eksportam un tāpēc Vācijā nav iegādājams!

**Selecta/Unica'B 27780000**

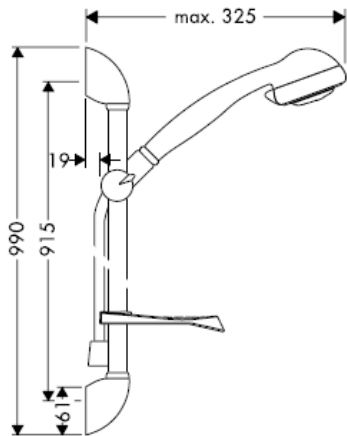

**Selecta/Unica'B 27781000**

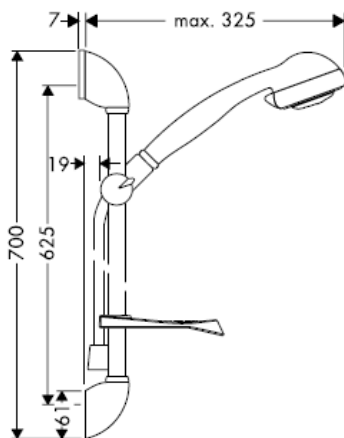

Dušas stienis 27824XXX ir paredzēts tikai eksportam un tāpēc Vācijā nav iegādājams!

**Selecta 2jet/Unica'B 27786000**

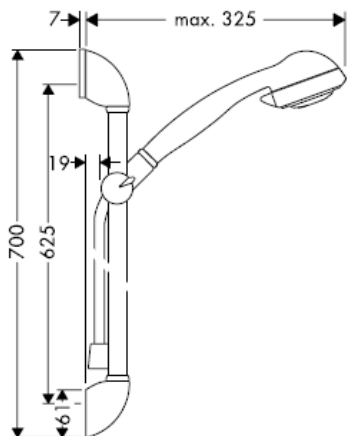

Dušas stienis 27824XXX ir paredzēts tikai eksportam un tāpēc Vācijā nav iegādājams!

## Selecta

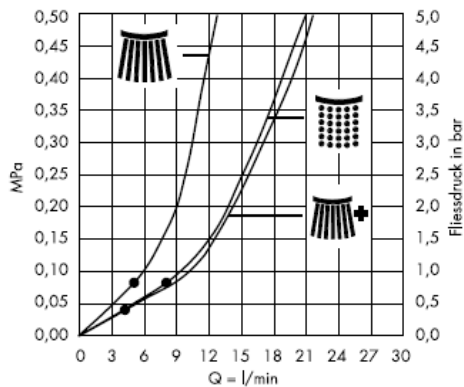

## Selecta 2jet

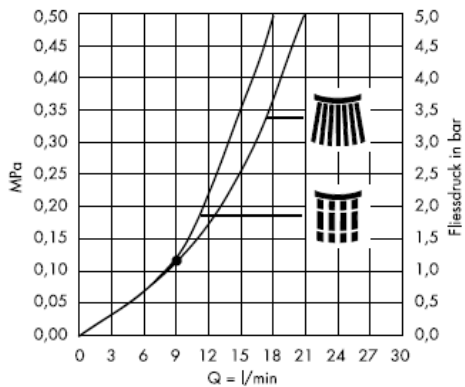

No • funkcija nodrošināta



Standarta strūkļa



Standarta strūkļa +  
Waterdimmer®  
(caurteces  
ierobežotājs)



Maiga strūkļa



Masāžas strūkļa

## Tehniskie dati

Darba spiediens: max. 0,6 MPa  
Ieteicamais darba spiediens: 0,1 – 0,4 MPa  
(1 MPa = 10 bar = 147 PSI)  
Karstā ūdens temperatūra: max 60°C

Hansgrohe viensviras jaucējkrānus var izmantot kombinācijā ar hidrauliski un termiski vadāmiem caurteces sildītājiem, ja plūsmas spiediens ir vismaz 0,15 MPa.

## Pārbaudes zīme

	DVGW	P-IX	SVGW	ACS	NF	WRAS	KIWA
27700XXX							
27705XXX							
27780000							
27781000				X			
27786000				X			

Jāiementē dušas komplektā esošais filtrs, lai novērstu netīrumu ieplūšanu no ūdens vada. Ieskalotie netīrumi var traucēt dušas funkciju un / vai arī izraisīt rokas dušas daļu bojājumus, par kuriem Hansgrohe nenes atbildību.

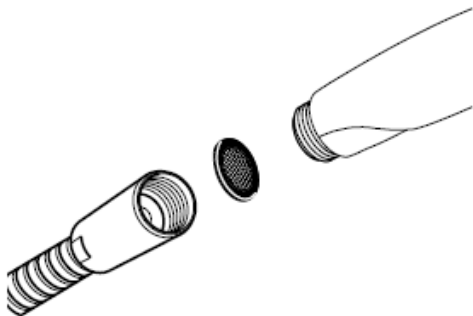

Ja izstrādājuma montāžu veic kvalificēti speciālisti, jāseko, lai nostiprināšanas virsma visā nostiprināšanas zonā būtu gluda (šuves un flīzes nav izvirzītas uz āru), lai sienas konstrukcija būtu piemērota izstrādājuma montāžai un būtu pietiekami izturīga. Komplektā esošās skrūves un dībeļi ir paredzēti tikai šī izstrādājuma nostiprināšanai. Ja sienas konstrukcija ir citāda, jāievēro dībeļu ražotāja norādījumi.

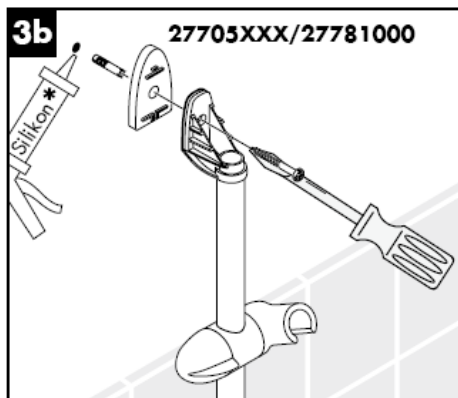
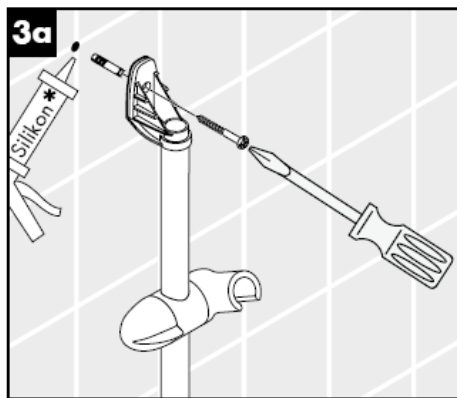
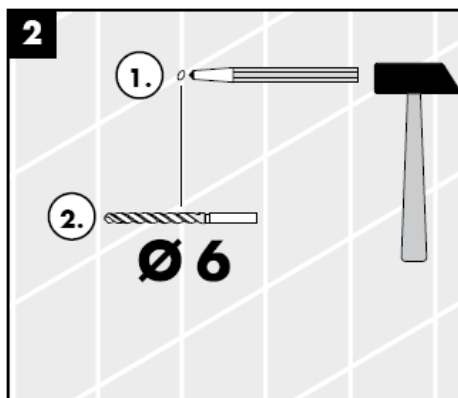
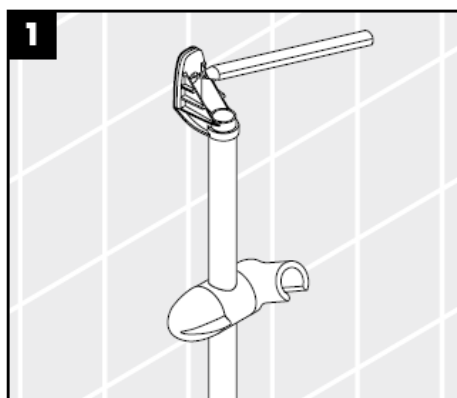

\* Silikons (etiškābi nesaturošs!)

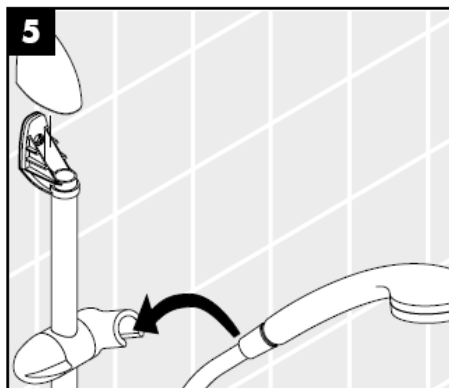
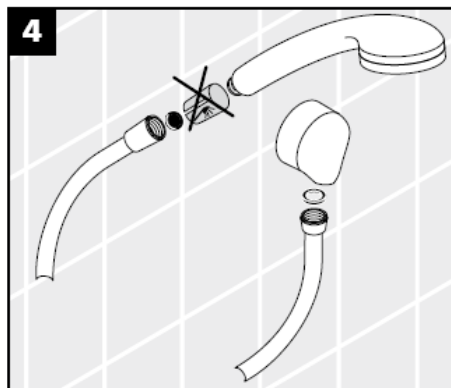

**Cassetta'B** 28686000

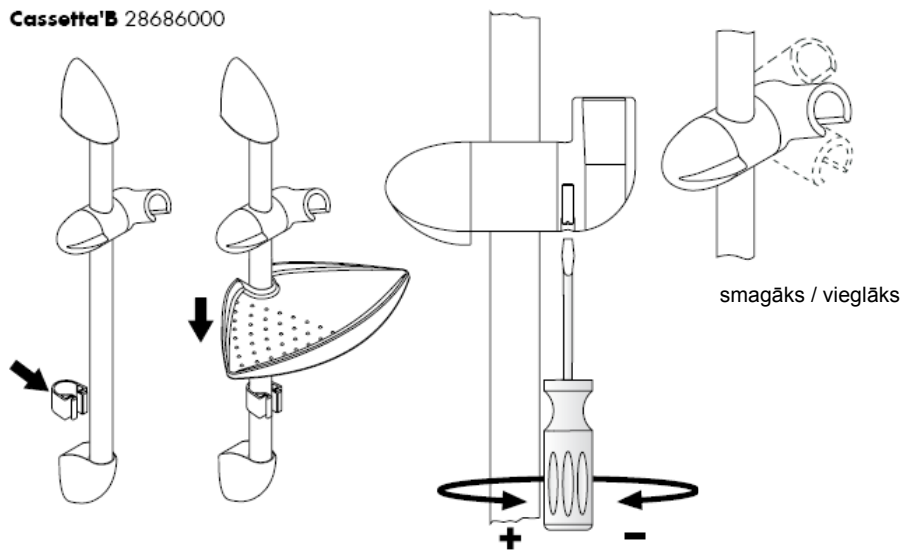

## Tīrīšana

Rubit® attīrīšanas funkcija - strūklas kanāliņi vienkāršas manuālas berzes rezultātā tiek attīrīti no kaļķa.

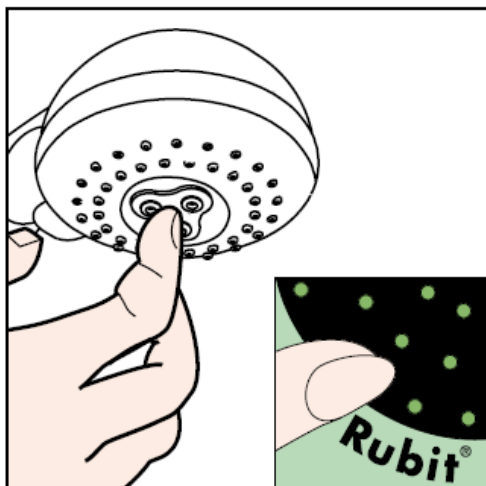

## Kopšanas instrukcija

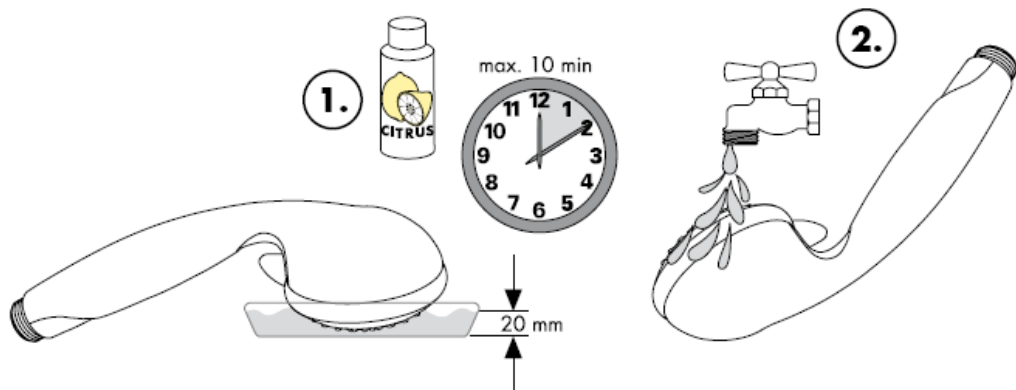

**hansgrohe**

# Uputstvo za montažu



**Unica'B**  
27700XXX



**Unica'B**  
27705XXX

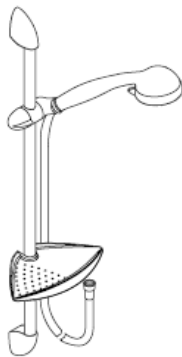

**Selecta/Unica'B**  
27780000/  
27781000



**Selecta 2jet/Unica'B**  
27786000

**hansgrohe**



Optimalno funkcionisanje je garantovano jedino u kombinaciji sa Hansgrohe ručnim tuševima i Hansgrohe crevom za tuš. Creva tuša prikladna su jedino za spajanje tuševa na armature. Nije dopušteno blokiranje creva u smeru protoka vode!

**Unica'B 27700XXX**

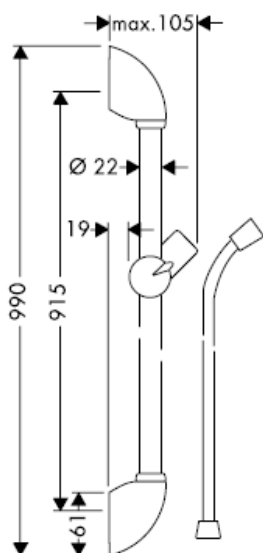

**Unica'B 27705XXX**

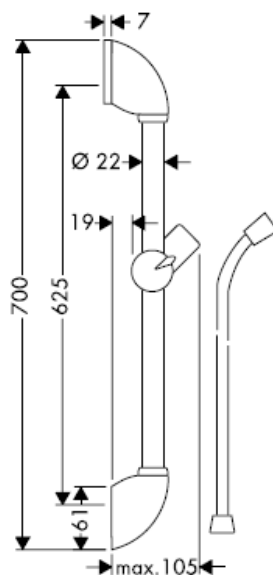

Šipka tuša 27824XXX je namenjena isključivo za izvoz i ne može se kupiti u Nemačkoj!

**Selecta/Unica'B 27780000**

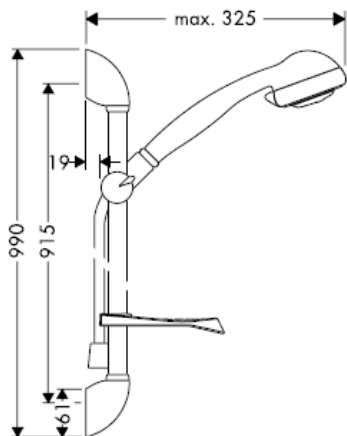

**Selecta/Unica'B 27781000**

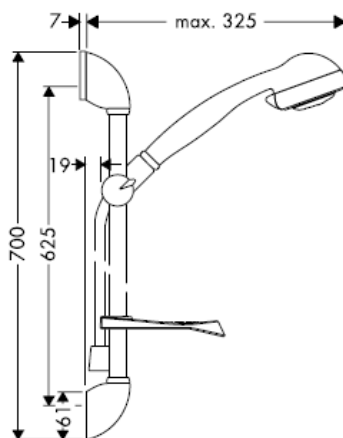

Šipka tuša 27824XXX je namenjena isključivo za izvoz i ne može se kupiti u Nemačkoj!

**Selecta 2jet/Unica'B 27786000**

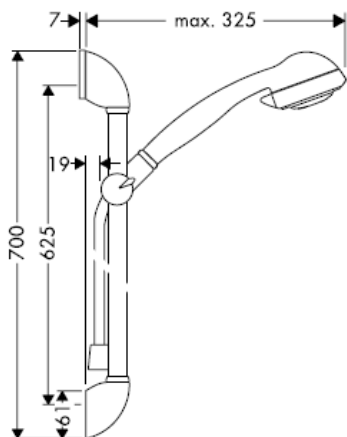

Šipka tuša 27824XXX je namenjena isključivo za izvoz i ne može se kupiti u Nemačkoj!

## Selecta

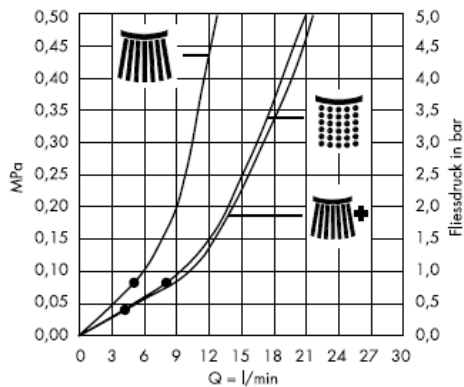

## Selecta 2jet

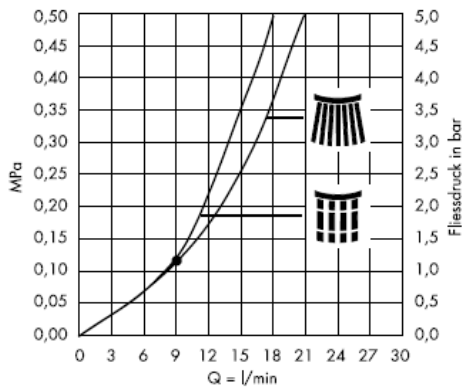

Od • je funkcija zagarantovana.



Normalni mlaz



Normalni mlaz +  
Waterdimmer  
(ograničavač protoka)



Nežni mlaz



Masažni mlaz

## Tehnički podaci

Radni pritisak:	max. 0,6 MPa
Preporučeni radni pritisak: (1 MPa = 10 bara = 147 PSI)	0,1 – 0,4 MPa
Temperatura vruće vode:	max 60°C

Hansgrohe jednoručni mešači se mogu koristiti s hidraulički i termički kontrolisanim protočnim bojlerima, ako je pritisak najmanje 0,15 MPa.

Kada proizvod montira kvalifikovano stručno osoblje treba paziti da čitava površina na koju se učvršćuje bude ravna (bez istaknutih fuga ili krivljenja pločica), da je zidna konstrukcija primerena montaži proizvoda, i posebno da nema slabih mesta.

Priloženi zavrtnji i tiplovi prikladni su samo za beton. Kod drugih zidnih nadgradnji treba obratiti pažnju na navode proizvođača tiplova.

## Ispitni znak

	DVGW	P-IX	SVGW	ACS	NF	WRAS	KIWA
27700XXX							
27705XXX							
27780000							
27781000				X			
27786000				X			

Obavezno ugradite mrežicu (A) upakovanu s tušem, čime sprečavate ulazak prljavštine iz vodovoda. Prljavština može dovesti do delimičnog ili potpunog oštećenja delova tuša. Za eventualna oštećenja uzrokovana prljavštinom proizvođač Hansgrohe nije odgovoran.

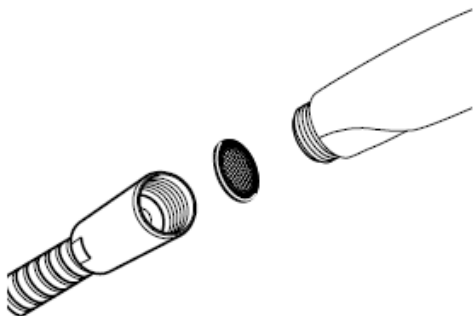

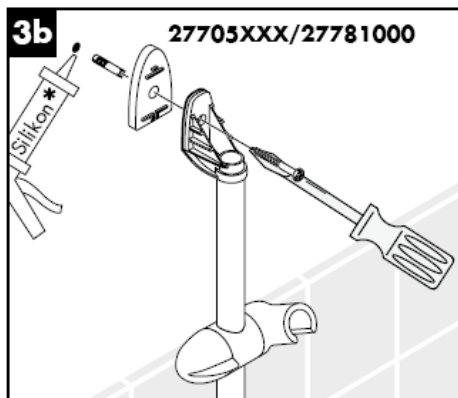
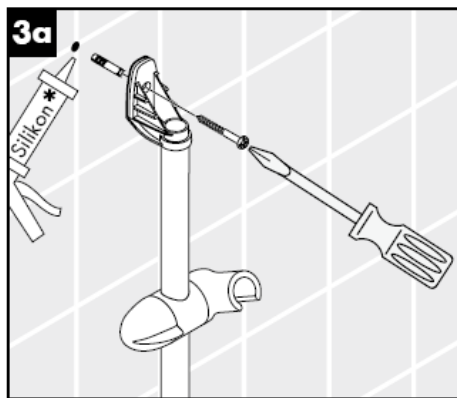
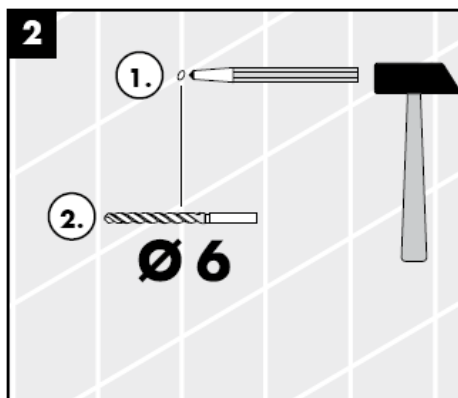
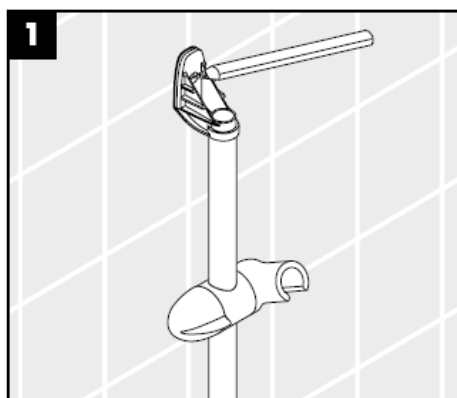

\* Silikon (ne sadrži sirčetnu kiselinu!)

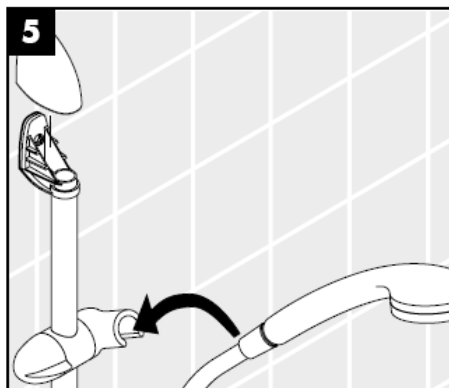
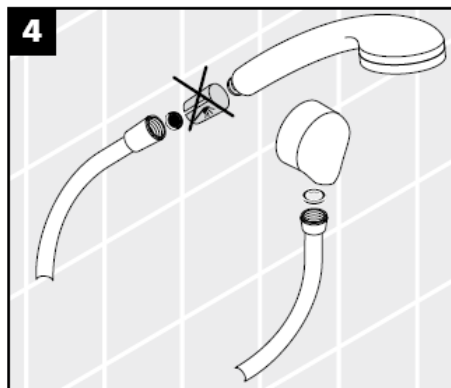

**Cassetta'B** 28686000

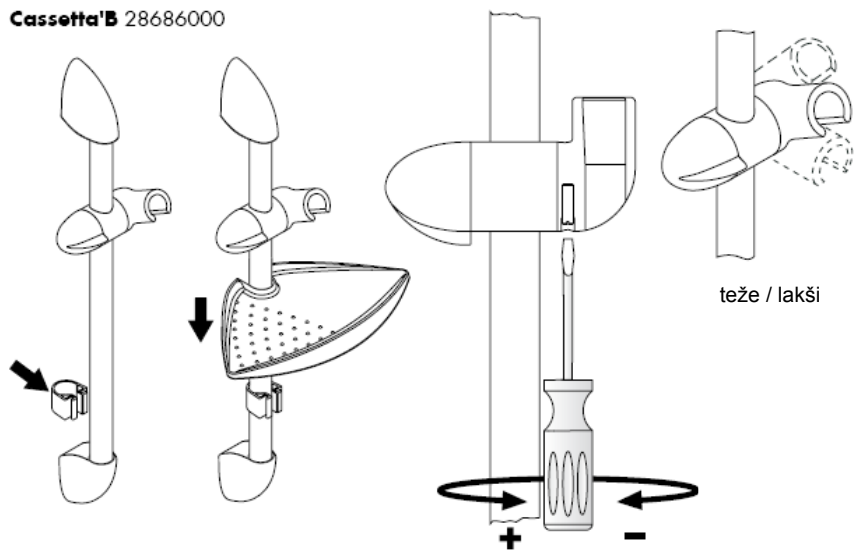

## Čišćenje

Rubit® - ručni sistem za čišćenje omogućuje odstranjivanje kamenca s rupica uobličavača mlaza, jednostavnim trljanjem.

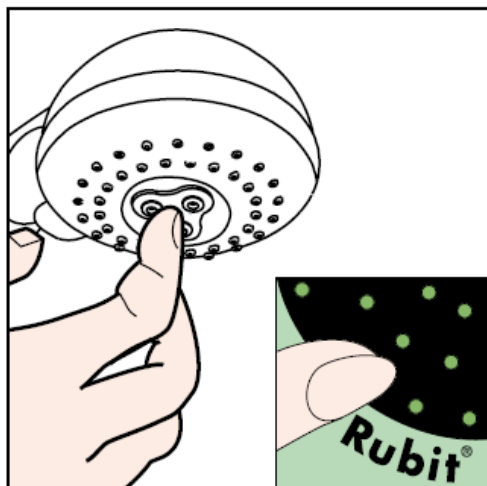

### Uputstvo za održavanje

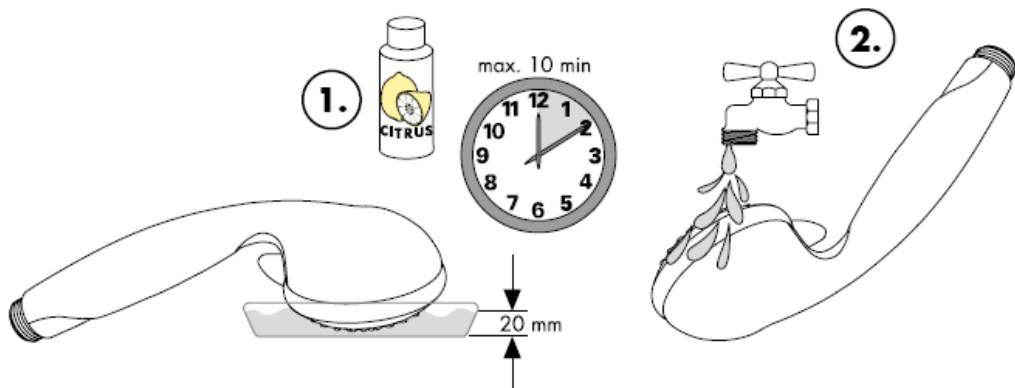

**hansgrohe**