

Montageanleitung



Talis E

33001000/33002XXX/33006000
33007000/33008000/33011000



Talis E

33200XXX/33202XXX/33208000

hansgrohe

33001000

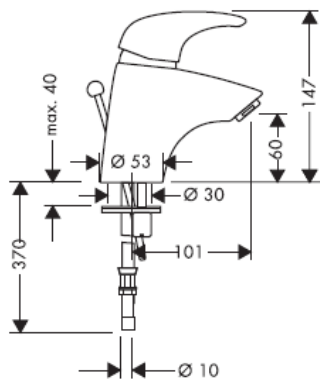

33200XXX

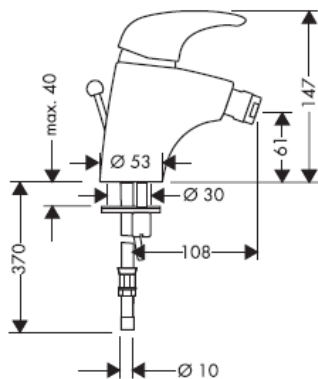

33002XXX

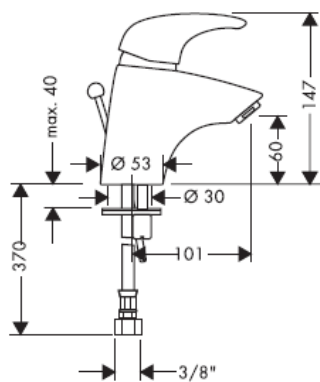

33202XXX

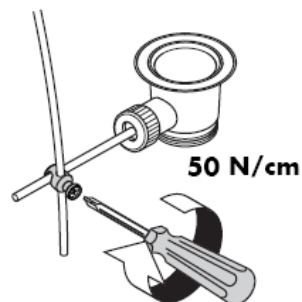
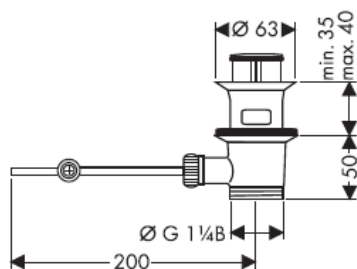
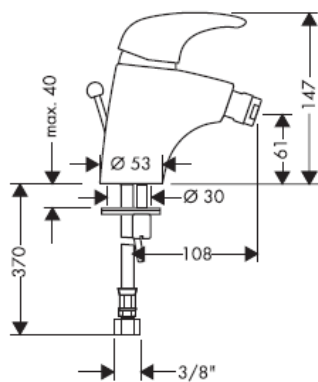

33008000

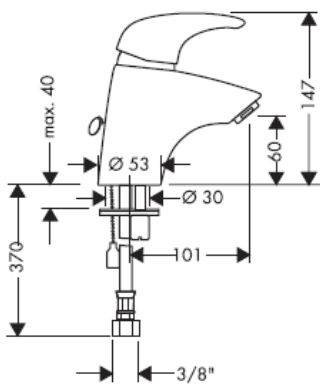

33208000

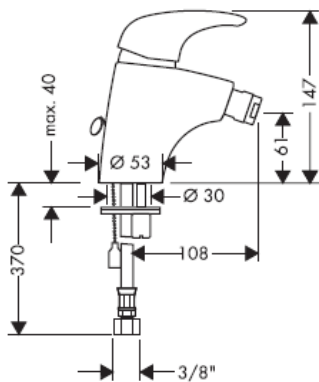

33006000

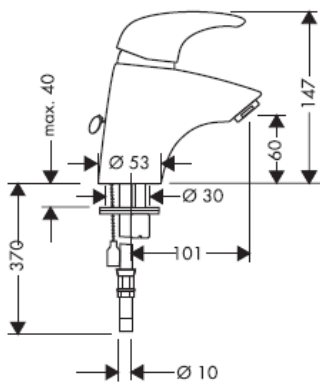

33007000

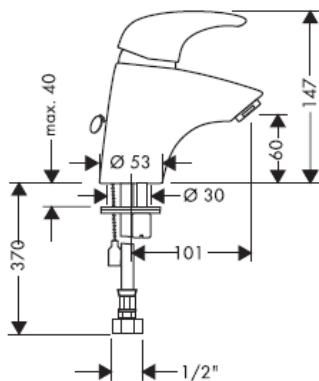

33011000

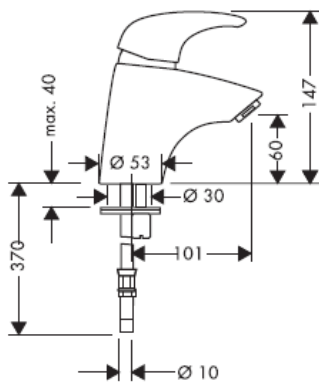

Montage Anschlusschlauch

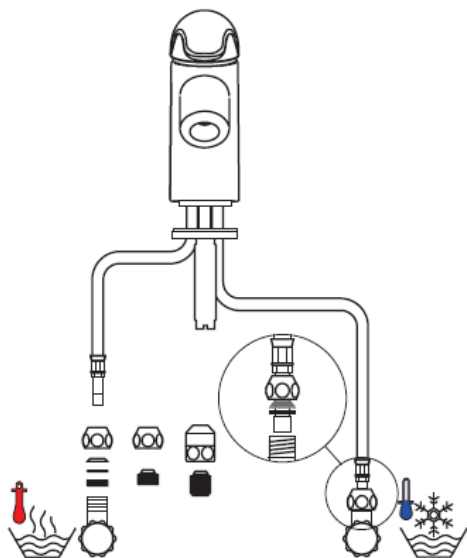
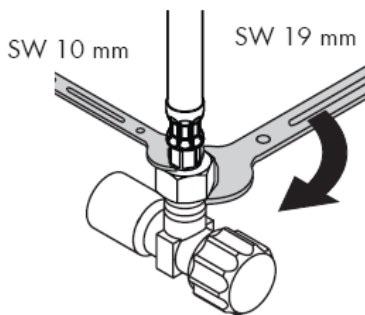
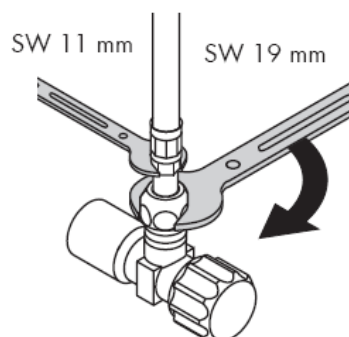
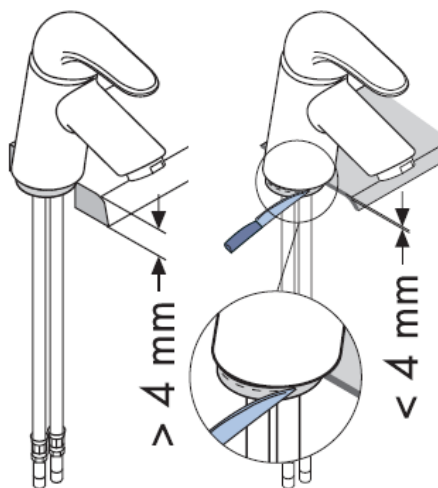
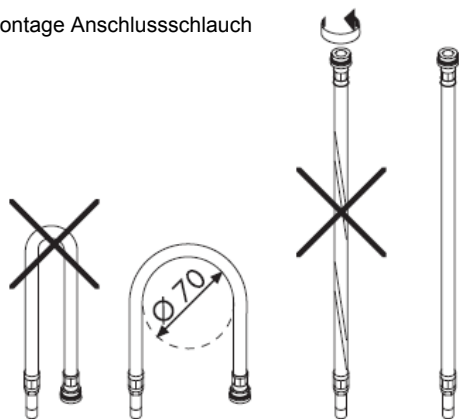

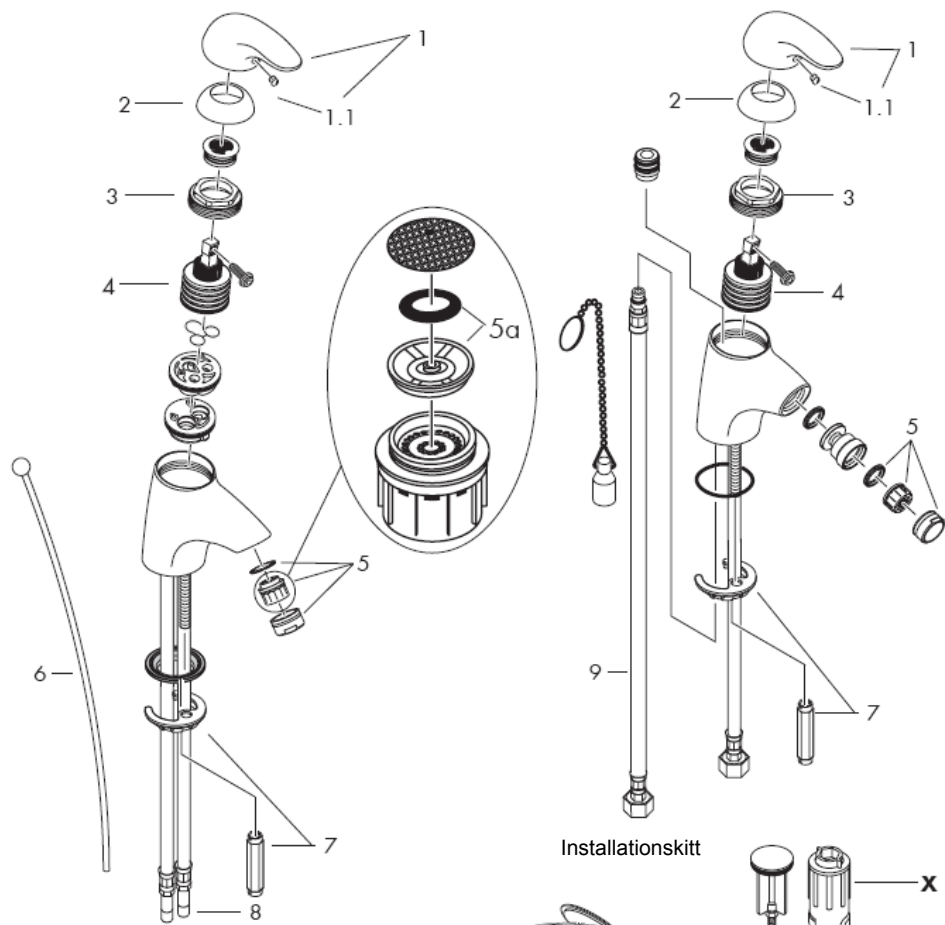

Installationskit

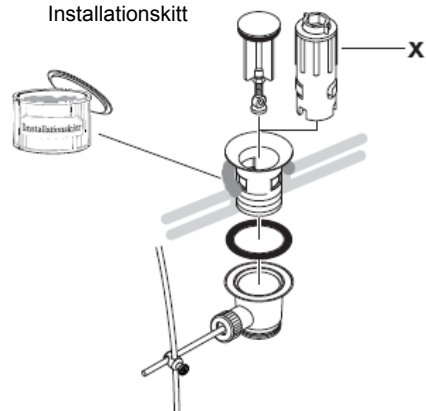

Achtung! Die Armatur muss nach den gültigen Normen montiert, gespült und geprüft werden!

Montage

- 1 Zulaufleitungen fachgerecht durchspülen.
- 2 Armatur mit Zwischenlage in Waschtisch / Bidet einsetzen.
- 3 Unterlagscheibe und Befestigungsscheibe über die Anschlussrohre und Gewindestift schieben und mit Mutter festziehen.
- 4 Anschlussschläuche an Eckventile anschließen, kalt rechts - warm links.
- 5 33001000/32002XXX/33200XXX/
33202XXX: Zugstange mit Ablaufventil verbinden.

Große Druckunterschiede zwischen den Kalt- und Warmwasseranschlüssen müssen ausgeglichen werden.

Bedienung

Durch Anheben des Griffes wird der Mischer geöffnet.

Schwenkung nach links = warmes Wasser,
Schwenkung nach rechts = kaltes Wasser.

Technische Daten

Armatur serienmäßig mit Waterdimmer® (Durchflussbegrenzer).

Durchflussleistung mit Waterdimmer: 7 l/min 0,3 MPa

Durchflussleistung ohne Waterdimmer: 12 l/min 0,3 MPa

Betriebsdruck: max. 1 MPa

Empfohlener Betriebsdruck: 0,1 – 0,5 MPa

Prüfdruck: 1,6 MPa

(1 MPa = 10 bar = 147 PSI)

Empfohlene Heißwassertemperatur: max 80° C

Empfohlene Heißwassertemperatur: 60° C

Hansgrohe Einhandmischer können in Verbindung mit hydraulisch und thermisch gesteuerten Durchlauferhitzern eingesetzt werden wenn der Fließdruck mindestens 0,15 MPa beträgt.

Bei Problemen mit dem Durchlauferhitzer oder wenn mehr Wasserdurchsatz gewünscht wird, kann der Waterdimmer® (Durchflussbegrenzer 5a), der hinter dem Luftsprudler sitzt entfernt werden.

Einhandmischer mit Warmwasserbegrenzung, Justierung siehe Seite 8.

In Verbindung mit Durchlauferhitzern ist eine Warmwassersperre nicht notwendig.

Serviceteile siehe Seite 5

1	Griff	33091000
1.1	Griffstopfen	94191000
2	Kappe	94192000
	Kappe gold	94192990
3	Mutter	94194000
4	Kartusche kpl.	92730000
5	Luftsprudler kpl. (10)	13912000
	Luftsprudler kpl. gold	94980990
	Luftsprudler kpl. (6 l/min)	96788000
6	Zugstange	92620000
	Zugstange gold-optik	92620990
7	Schaftbefestigung	96016000
8	Anschluss Schlauch	95001000
9	Anschluss Schlauch	97206000

Sonderzubehör

X Montageschlüssel Set 58085000
(nicht im Lieferumfang enthalten)

Deutsch

Prüfzeichen

	DVGW	P-IX	SVGW	ACS	NF	WRAS	KIWA
33001000	X	P-IX 8388/IA	X			X	X
33002XXX	X	P-IX 8388/IA	X		X		X
33006000	X	P-IX 8388/IA	X				X
33007000							
33008000	X	P-IX 8388/IA	X		X		X
33011000							
33200XXX	X	P-IX 8388/IA	X			X	X
33202XXX	X	P-IX 8388/IA	X		X		X
33208000	X	P-IX 8388/IA	X		X		X

Warmwasserbegrenzung: Warmwassertemperatur 60 C, Kaltwassertemperatur 10 C, Fließdruck 0,3 MPa.

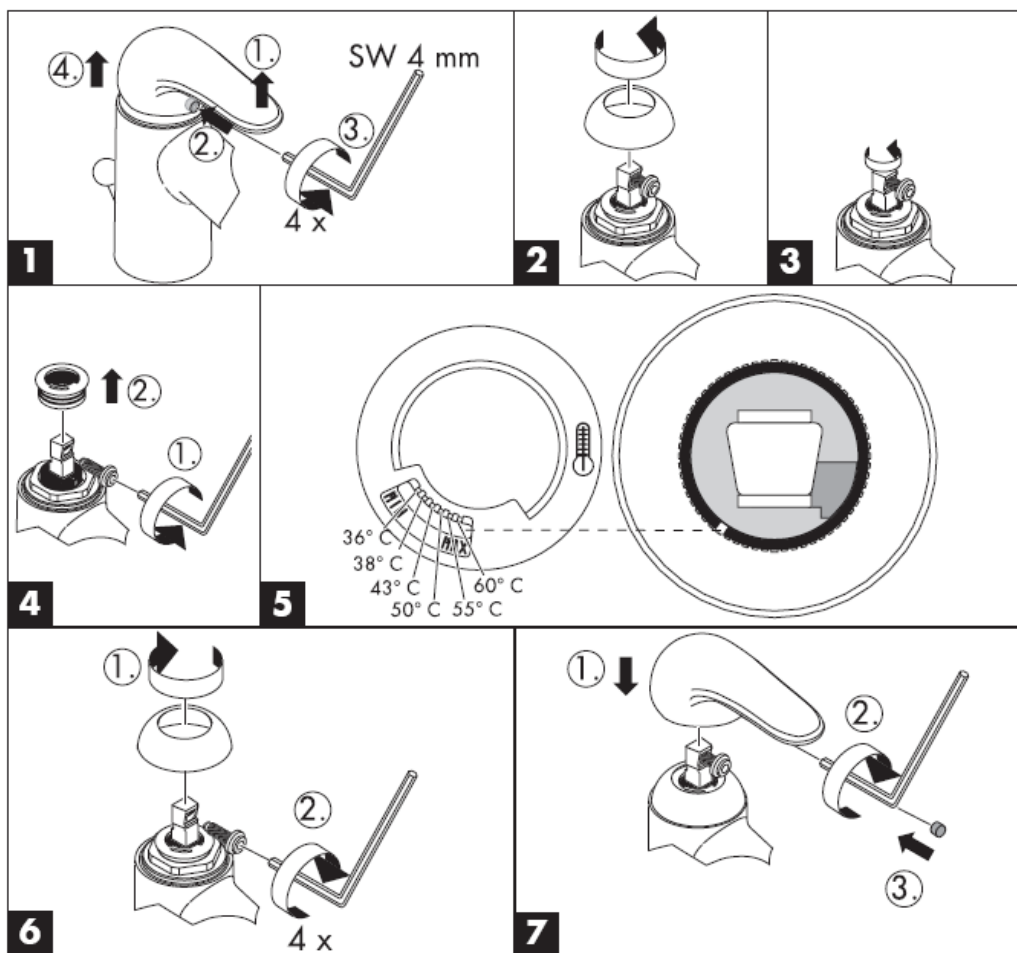

Reinigung

Mit Rubit®, der manuellen Reinigungsfunktion können die Strahlformer durch einfaches rubbeln vom Kalk befreit werden.



hansgrohe

Hansgrohe · Postfach 1145 · D-77761 Schiltach · Telefon +49 (0) 78 36/51-1282 · Telefax +49 (0) 7836/511440
E-Mail: info@hansgrohe.com · Internet: www.hansgrohe.com

05/2006
9.07956.04
Deutsch

Instructions de montage



Talis E

33001000/33002XXX/33006000
33007000/33008000/33011000



Talis E

33200XXX/33202XXX/33208000

hansgrohe

33001000

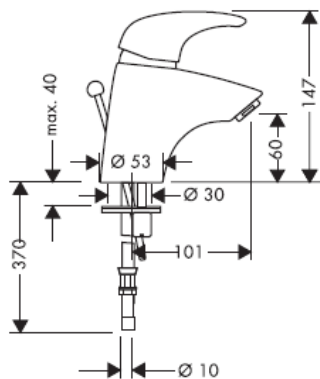

33200XXX

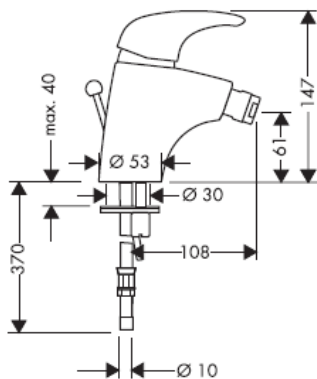

33002XXX

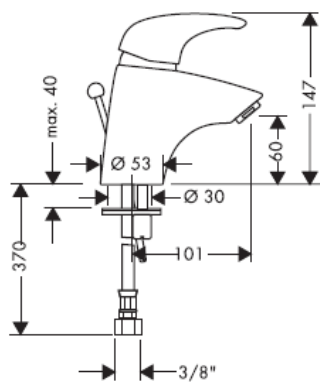

33202XXX

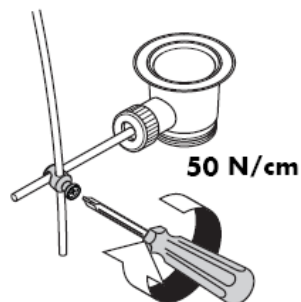
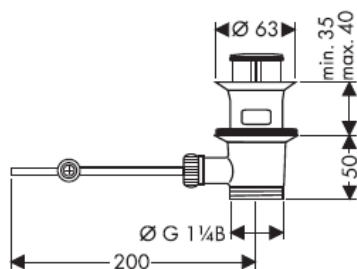
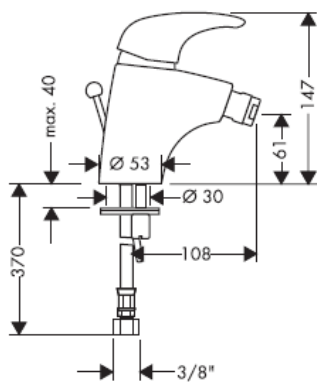

33008000

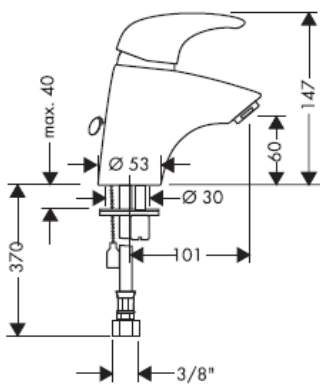

33208000

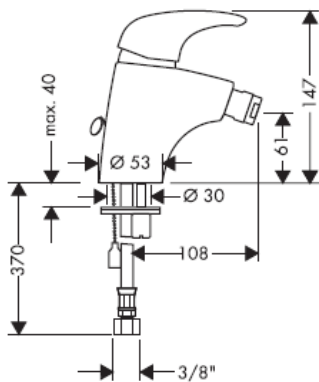

33006000

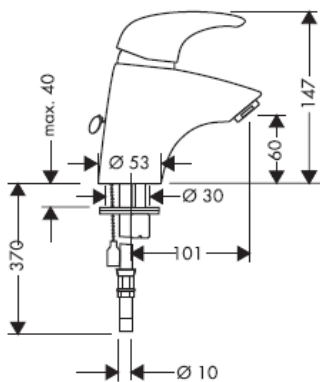

33007000

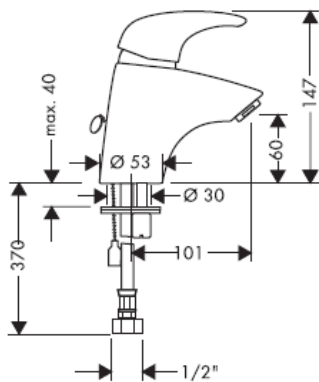

33011000

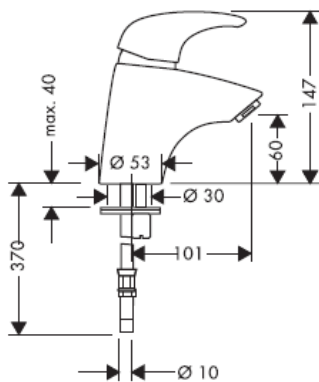

Montage flexible de
raccordement

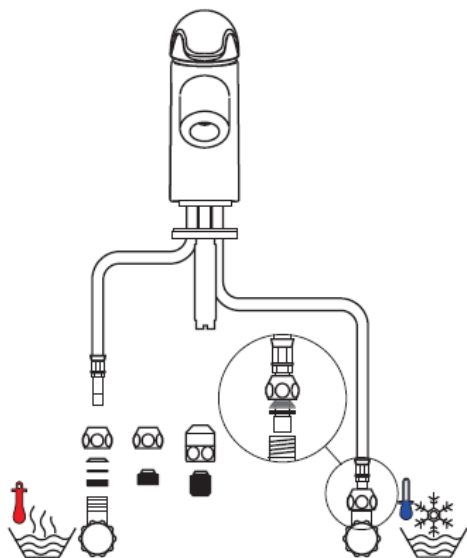
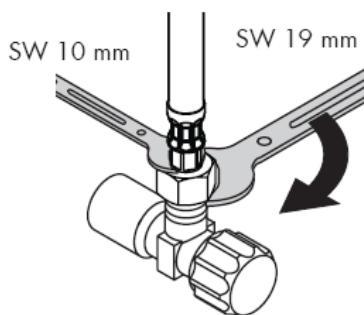
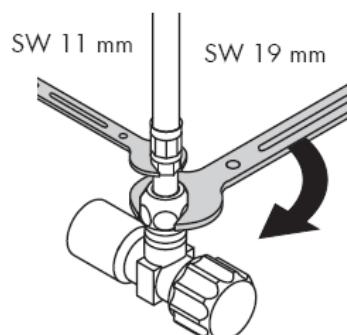
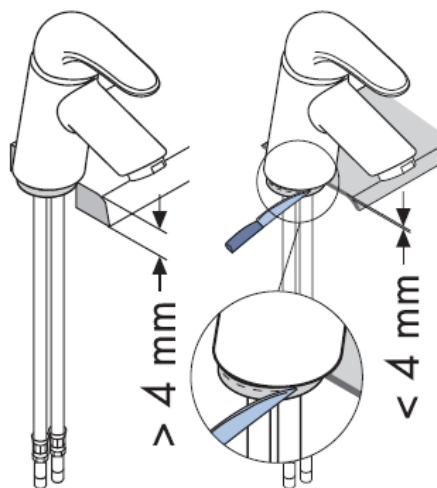
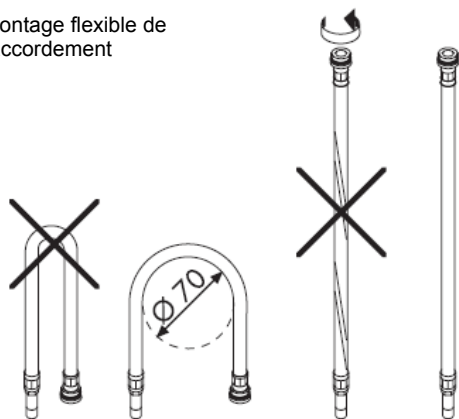

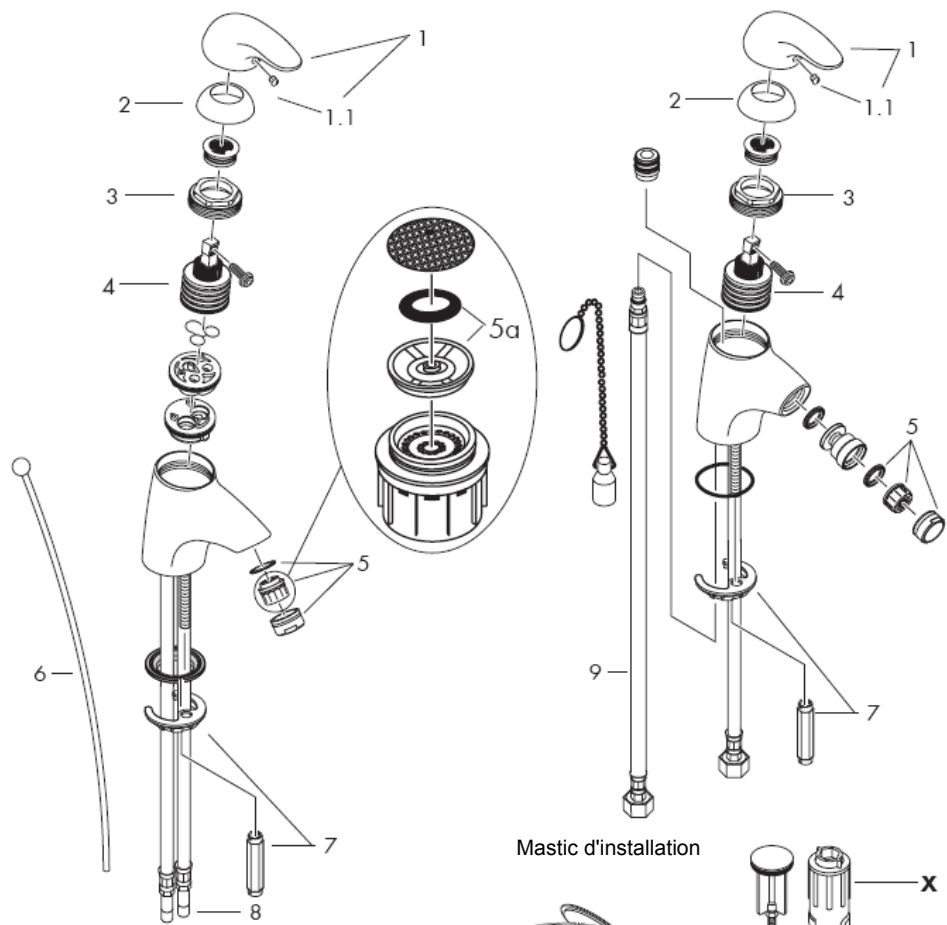

Mastic d'installation

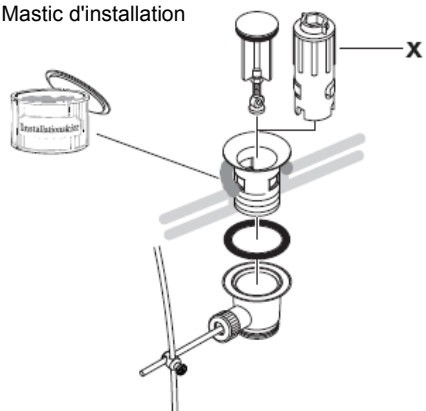

Attention! La robinetterie doit être installée, rincée et contrôlée conformément aux normes valables!

Montage

- 1 Purger les conduites d'alimentation.
- 2 Placer le mitigeur avec le joint caoutchouc sur le lavabo / bidet.
- 3 Mettre en place le disque métallique avec le disque caoutchouc et serrer l'écrou.
- 4 Branchement impératif par robinet d'arrêt et d'équerre ou par raccord avec bague de serrage en laiton et joint d'étanchéité; L'eau chaude à gauche - l'eau froide à droite.
- 5 33001000/32002XXX/33200XXX/
33202XXX: Fixer la tirette.

Il est conseillé d'équilibrer les pressions de l'eau chaude et froide.

Instructions de service

En levant ou appuyant l'étrier de commande on actionne l'ouverture ou la fermeture du mitigeur. Tournant sur la droite = eau froide, tournant sur la gauche = eau chaude.

Informations techniques

Cette robinetterie est en série équipée d'un waterdimmer® (limiteur de débit).

Débit avec waterdimmer:

7 l/min 0,3 MPa

Débit con waterdimmer:

12 l/min 0,3 MPa

Pression de service autorisée: max. 1 MPa

Pression de service conseillée: 0,1 – 0,5 MPa

Pression maximum de contrôle: 1,6 MPa
(1 MPa = 10 bar = 147 PSI)

Température recommandée: max 80° C

Température recommandée: 60° C

Les mitigeurs monocommandes Hansgrohe fonctionnent également en association à des chauffe-eau à commande hydraulique ou thermique à condition que la pression soit au minimum de 0,15 MPa.

Dans ce cas, veuillez enlever sur le mitigeur de lavabo le waterdimmer® (limiteur de débit 5a) qui se trouve derrière l'aérateur.

Mitigeur avec limitation de la température: consulter la page 8 pour le réglage
Une limitation de la température n'est pas nécessaire quand le mitigeur est alimenté par un chauffe-eau instantané.

Pièces détachées voir pages 5

1	poignée	33091000
1.1	cache vis	94191000
2	flange	94192000
	Capuchon or	94192990
3	écrou	94194000
4	cartouche cpl.	92730000
5	aérateur cpl. (10)	13912000
	aérateur cpl. gold	94980990
	aérateur cpl. (6 l/min)	96788000
6	tirette	92620000
	tirette or l'optique	92620990
7	fixation	96016000
8	flexible de raccordements	95001000
9	flexible de raccordements	97206000

Accessoires en option

X clé de montage 58085000
(non livrés avec)

Français

Classification acoustique et débit

	DVGW	P-IX	SVGW	ACS	NF	WRAS	KIWA
33001000	X	P-IX 8388/IA	X			X	X
33002XXX	X	P-IX 8388/IA	X		X		X
33006000	X	P-IX 8388/IA	X				X
33007000							
33008000	X	P-IX 8388/IA	X		X		X
33011000							
33200XXX	X	P-IX 8388/IA	X			X	X
33202XXX	X	P-IX 8388/IA	X		X		X
33208000	X	P-IX 8388/IA	X		X		X

Limiteur d'eau chaude: Température d'eau chaude 60 C, Température d'eau froide 10 C, Pression dynamique 0,3 MPa.

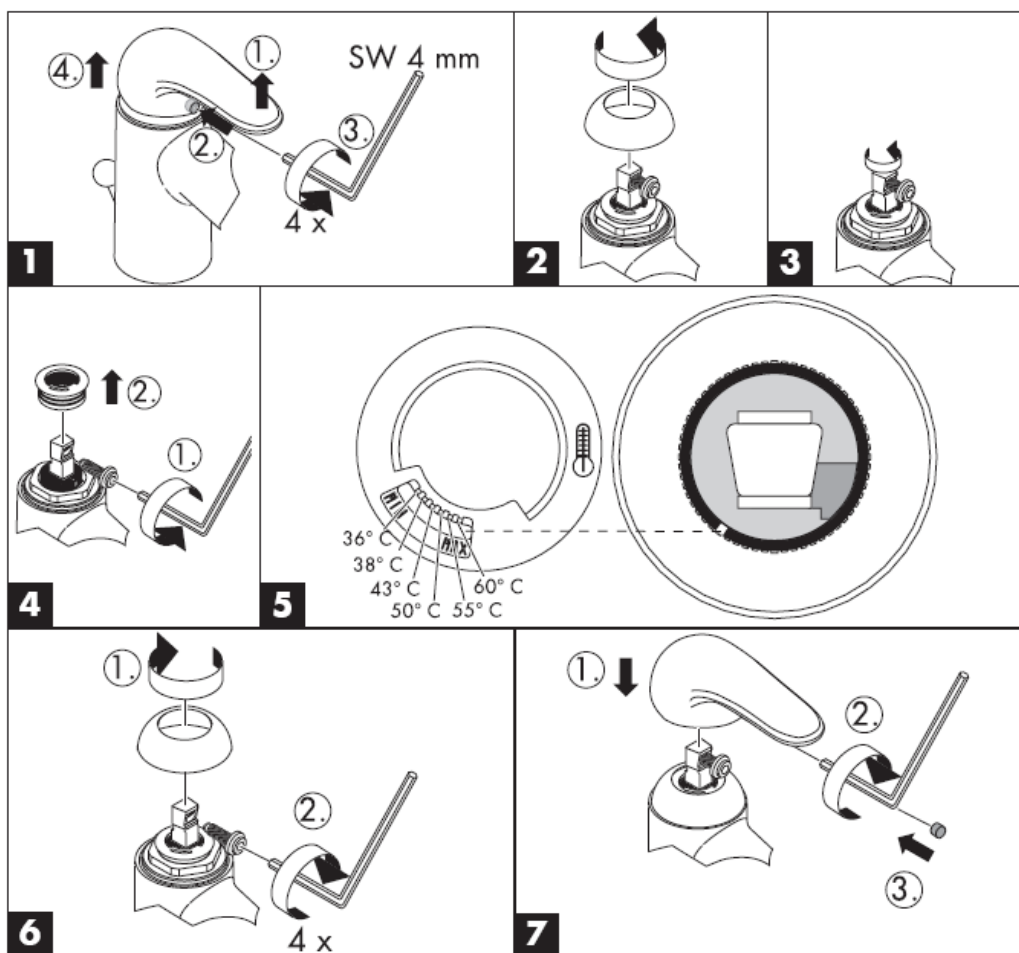

Nettoyage

La pomme de douche est équipée de Rubit®, le système anticalcaire manuel. Les dépôts de calcaire s'enlèvent en frottant avec un doigt ou avec une éponge sur les ouvertures de jets élastiques.



hansgrohe

Hansgrohe · Postfach 1145 · D-77761 Schiltach · Telefon +49 (0) 78 36/51-1282 · Telefax +49 (0) 7836/511440
E-Mail: info@hansgrohe.com · Internet: www.hansgrohe.com

05/2006
9.07956.04
Français

assembly instructions



Talis E

33001000/33002XXX/33006000
33007000/33008000/33011000



Talis E

33200XXX/33202XXX/33208000

hansgrohe

33001000

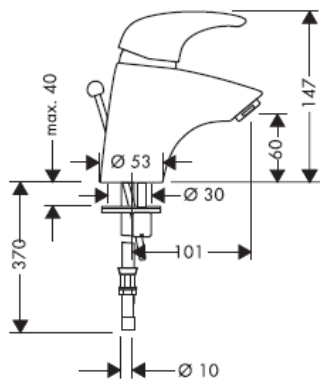

33200XXX

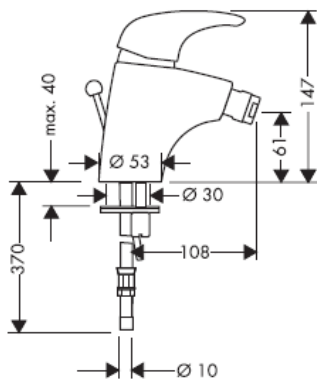

33002XXX

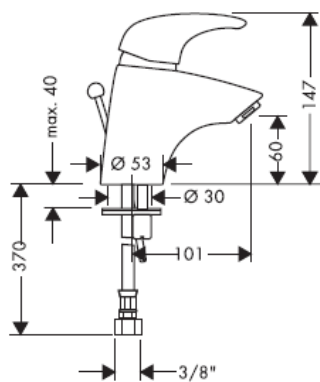

33202XXX

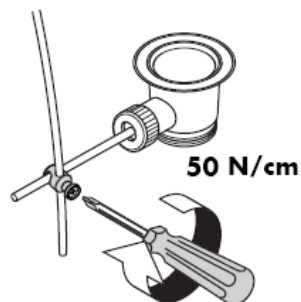
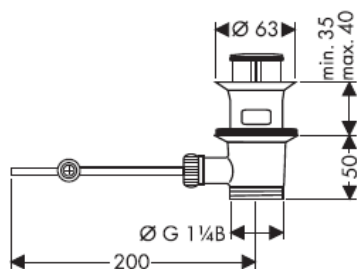
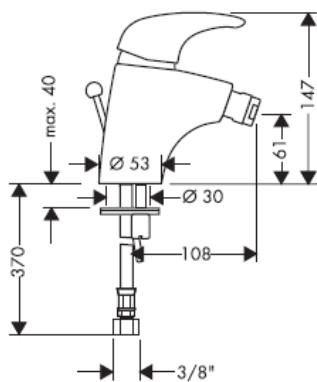

33008000

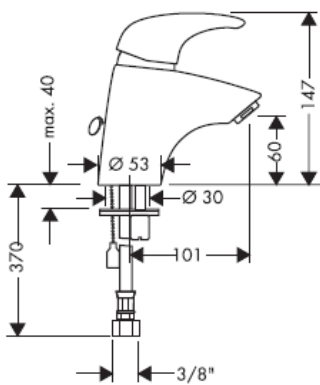

33208000

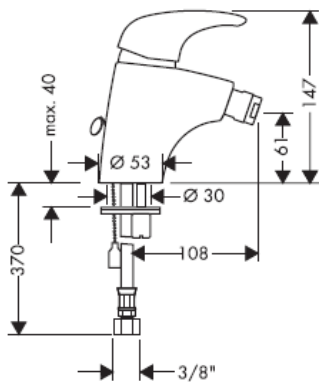

33006000

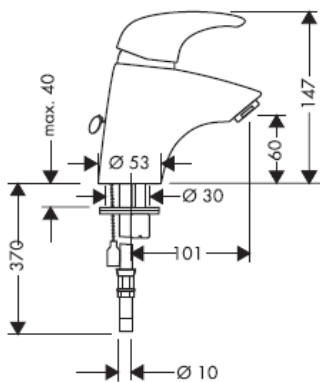

33007000

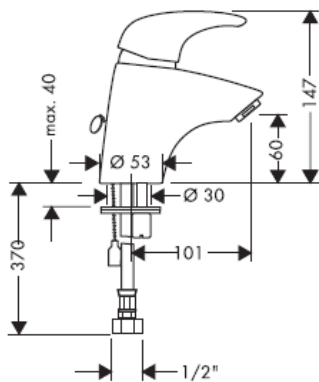

33011000

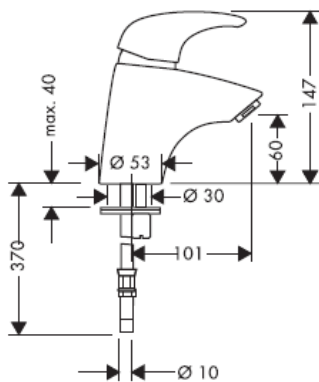

Assembly connecting hoses

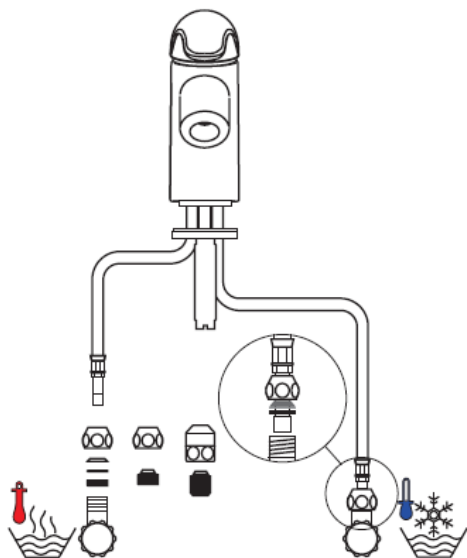
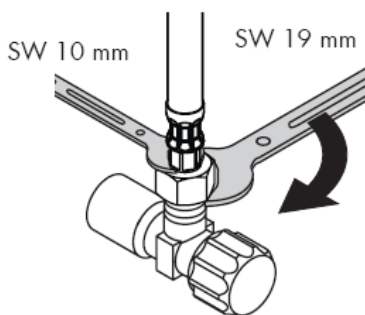
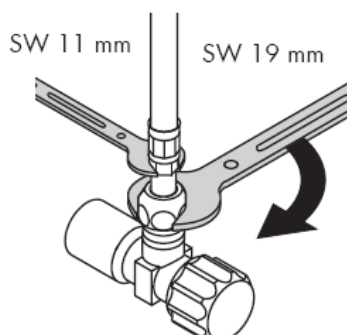
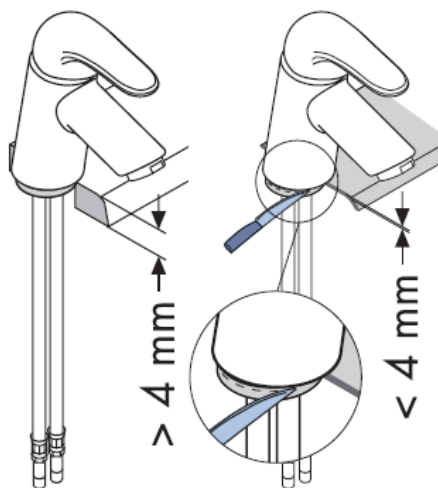
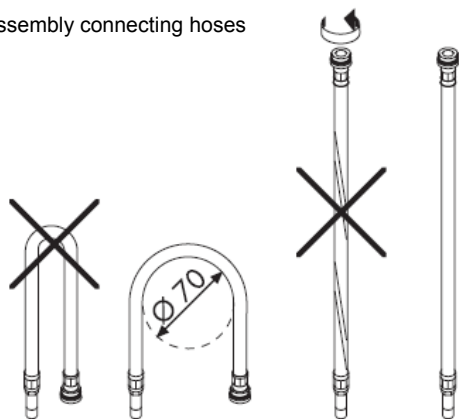

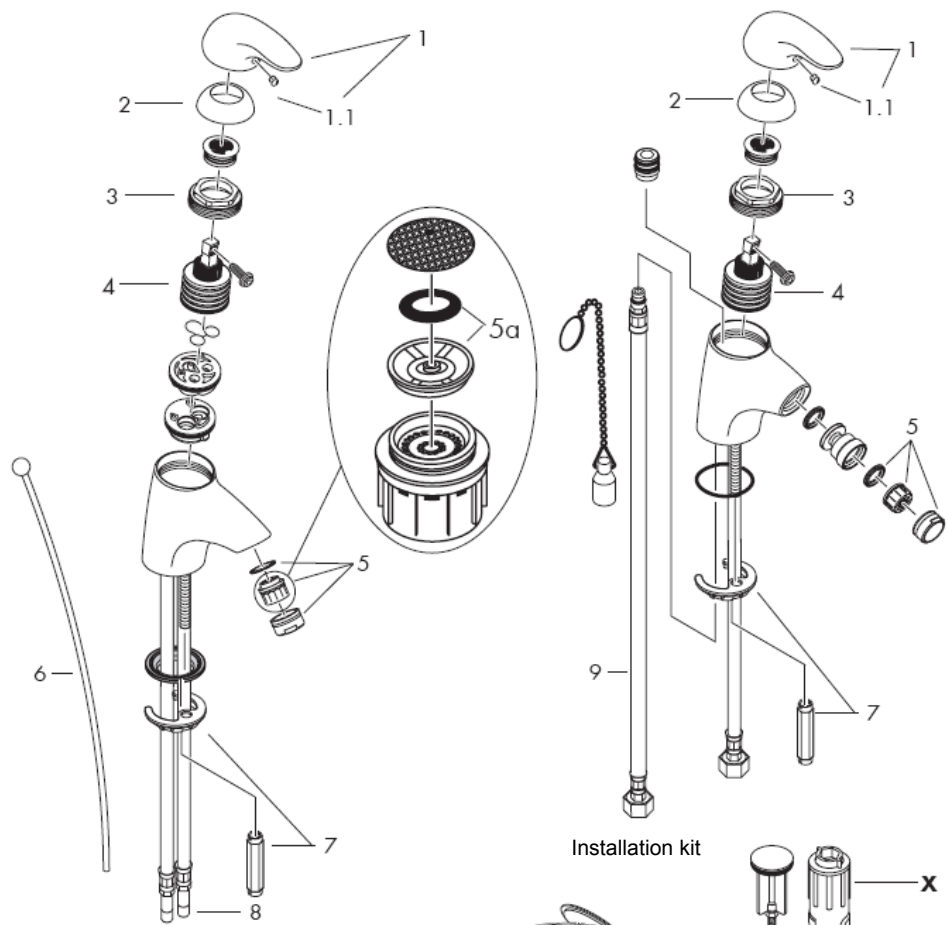

Installation kit

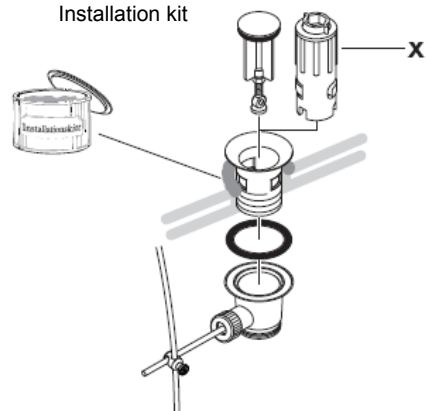

Important! The fitting must be installed, flushed and tested after the valid norms!

Assembly

- 1 Flush through the supply pipes.
- 2 Place the mixer including the sealing washer in position on the basin / bidet.
- 3 Slide the fixation piece including the washer over the threaded pins and tighten the nuts.
- 4 Connect the supply pipes to the isolation valves; cold right - hot left.
- 5 33001000/32002XXX/33200XXX/
33202XXX: Connect the pull rod to the pop-up waste.

The hot and cold supplies must be of equal pressures.

Operation

The mixer is activated by lifting the lever handle. Turning to the left = warmer water, turning to the right = cooler water.

Technical Data

This mixer series-produced with waterdimmer® (flow limiter).

Rate of flow with waterdimmer:

7 l/min 0,3 MPa

Rate of flow without waterdimmer:

12 l/min 0,3 MPa

Operating pressure: max. 1 MPa

Recommended operating pressure: 0,1 – 0,5 MPa

Test pressure: 1,6 MPa

(1 MPa = 10 bar = 147 PSI)

Recommended hot water temp.: max 80° C

Recommended hot water temp.: 60° C

Hansgrohe single lever mixers can be used together with hydraulically and thermally controlled continuous flow heaters if the flow pressure is at least 0,15 MPa.

If the continuous water heater causes any problems or there is not enough flow of water, the waterdimmer® (5a) located behind the aerator must be removed.

To adjust the hot water limiter on single lever mixers, please see page 8.

No adjustment is necessary when using a continuous flow water heater.

Spare parts see page 5

1	handle	33091000
1.1	screw cover	94191000
2	flange	94192000
	Cap, gold	94192990
3	nut	94194000
4	cartridge cpl.	92730000
5	aerator cpl. (10)	13912000
	aerator cpl. gold	94980990
	aerator cpl. (6 l/min)	96788000
6	pull rod	92620000
	pull rod gold plated	92620990
7	fixing set	96016000
8	connection hose	95001000
9	connection hose	97206000

Special accessories

X special tool set 58085000
(order as an extra)

Test certificate

	DVGW	P-IX	SVGW	ACS	NF	WRAS	KIWA
33001000	X	P-IX 8388/IA	X			X	X
33002XXX	X	P-IX 8388/IA	X		X		X
33006000	X	P-IX 8388/IA	X				X
33007000							
33008000	X	P-IX 8388/IA	X		X		X
33011000							
33200XXX	X	P-IX 8388/IA	X			X	X
33202XXX	X	P-IX 8388/IA	X		X		X
33208000	X	P-IX 8388/IA	X		X		X

Hot water limiter: hot water temperature 60 C, cold water temperature 10 C, flow rate 0,3 MPa.

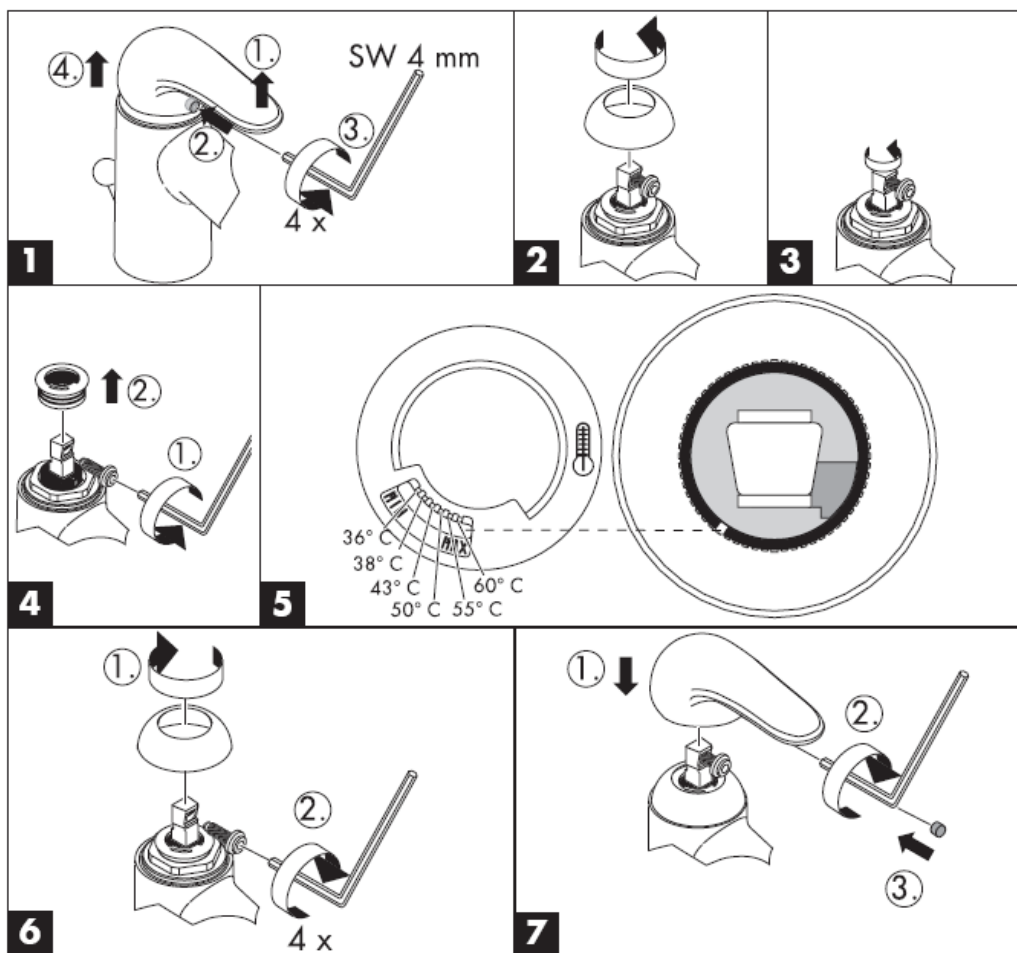

Cleaning

The Rubit® cleaning function only needs a small manual rub over to remove the lime scale from the spray channels.



hansgrohe

Hansgrohe · Postfach 1145 · D-77761 Schiltach · Telefon +49 (0) 78 36/51-1282 · Telefax +49 (0) 7836/511440
E-Mail: info@hansgrohe.com · Internet: www.hansgrohe.com

05/2006
9.07956.04
English

Istruzioni per Installazione



Talis E

33001000/33002XXX/33006000
33007000/33008000/33011000



Talis E

33200XXX/33202XXX/32208000

hansgrohe

33001000

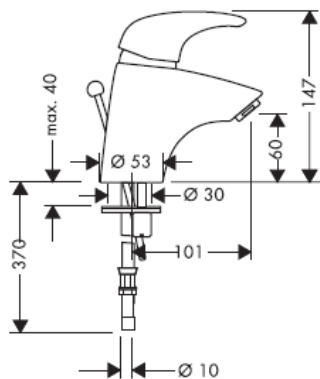

33200XXX

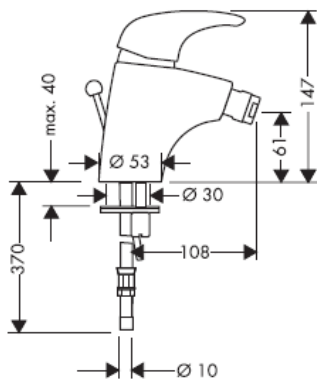

33002XXX

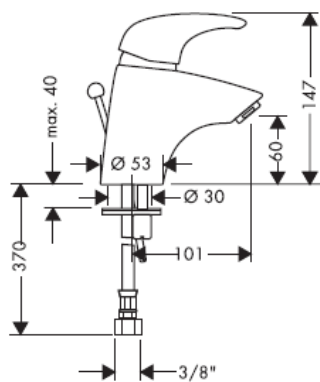

33202XXX

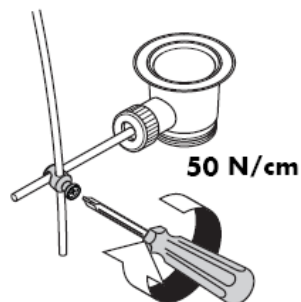
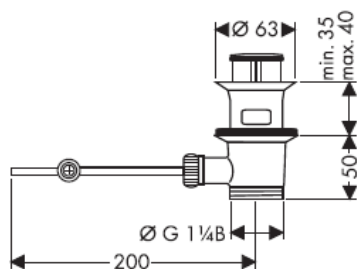
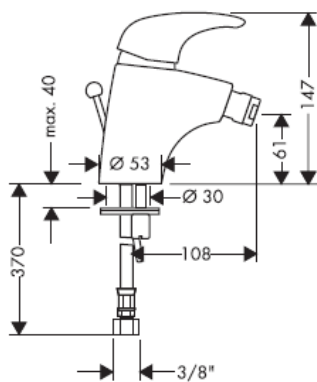

33008000

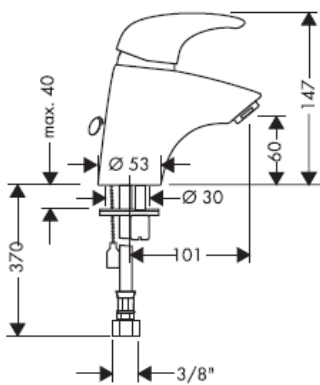

33208000

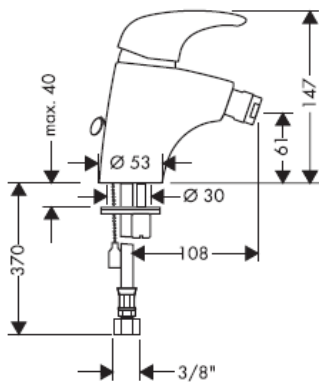

33006000

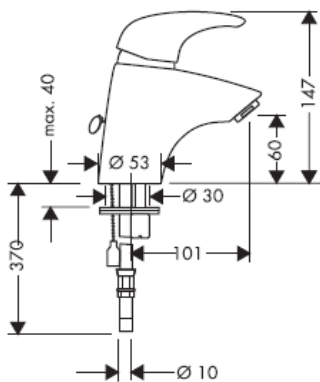

33007000

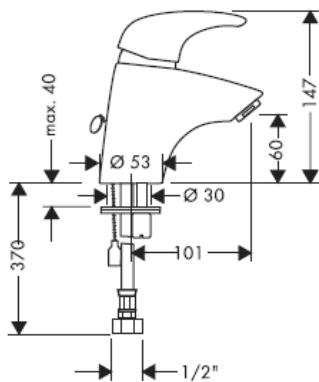

33011000

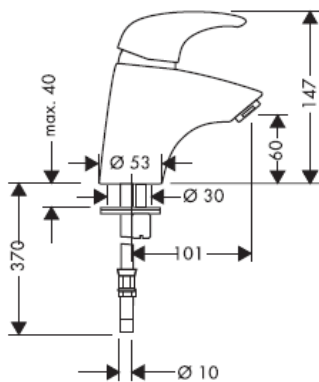

Montaggio flessibile

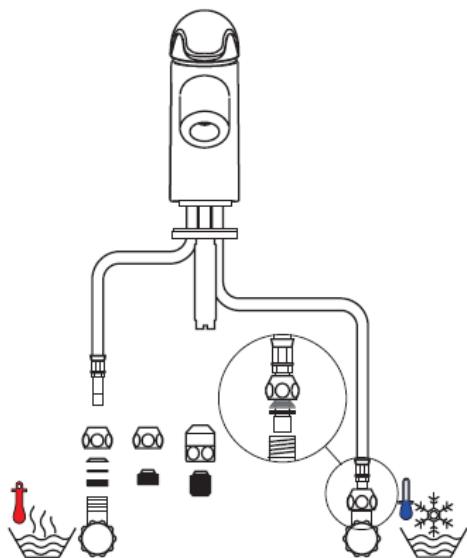
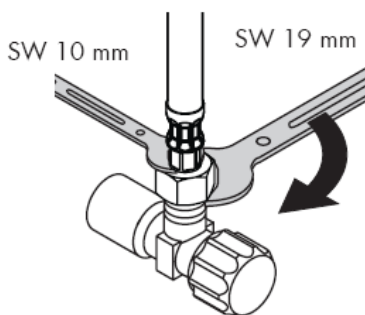
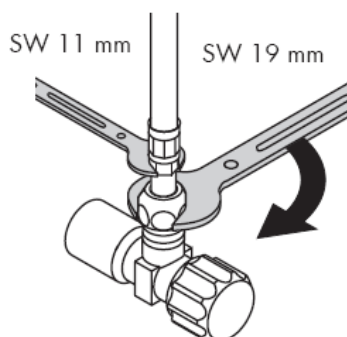
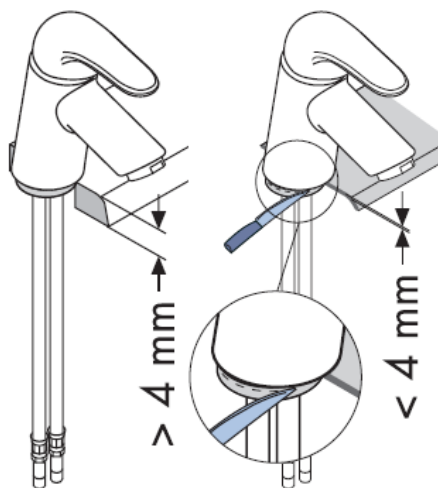
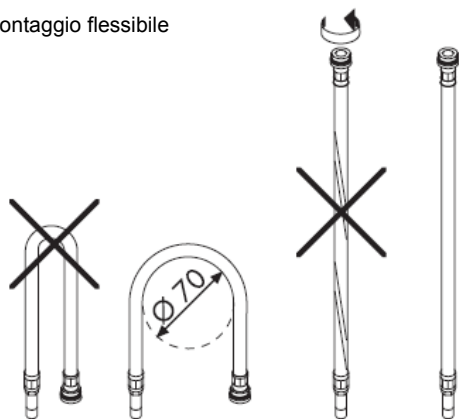

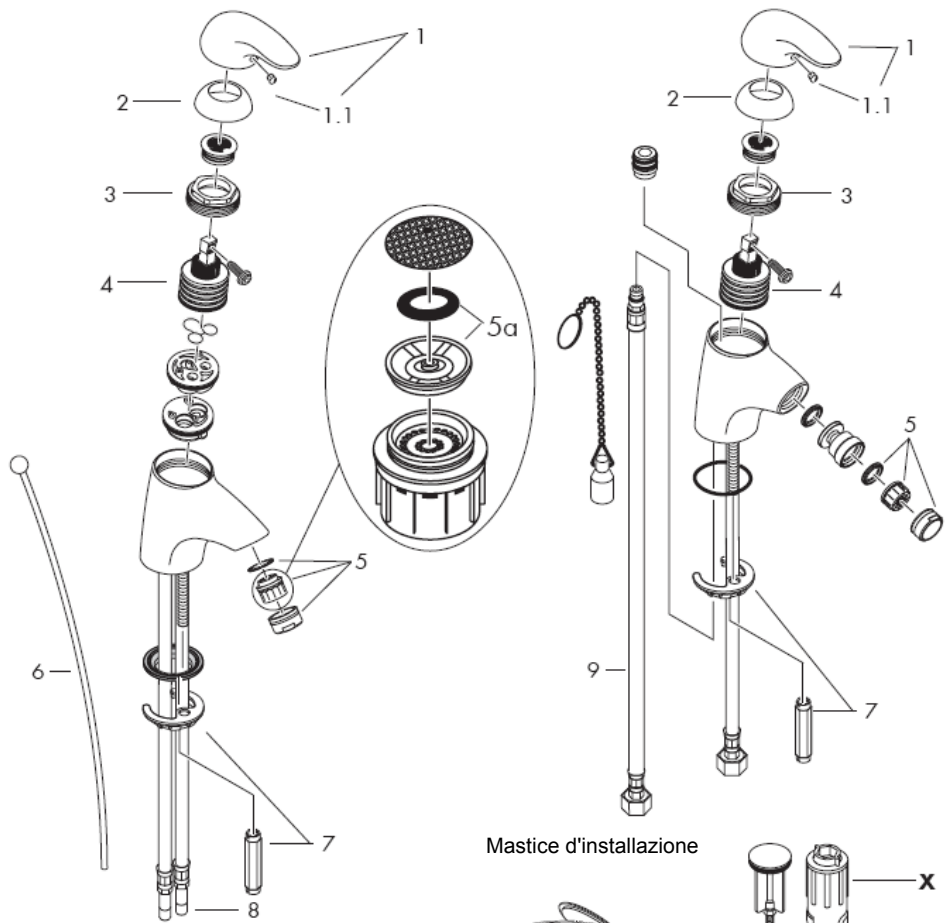

Mastice d'installazione

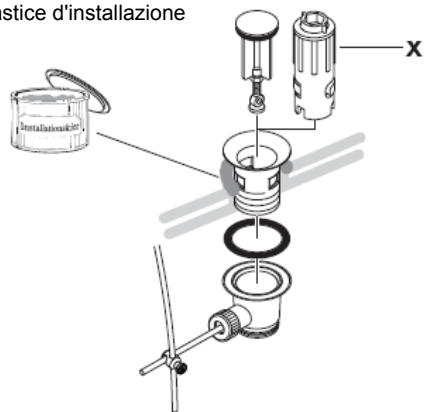

Attenzione! La rubinetteria deve essere installata, pulita e testata secondo le istruzioni riportate!

Montaggio

- 1 Collegare le uscite principali.
- 2 Inserire il rubinetto con spessore ne lavabo / bidet.
- 3 Inserire la rosetta scorrevole e la rosetta di appoggio sopra i tubi ed avvitare il dado.
- 4 Collegare i tubi collegamento alle valvole ad angolo.
- 5 Freddo a destra - caldo a sinistra.
- 6 33001000/32002XXX/33200XXX/
33202XXX: Collegare la barra di trazione alle valvola di scarico.

Attenzione! Compensare le differenze di pressione tra i collegamenti dell'acqua fredda e dell'acqua calda.

Procedura

Il miscelatore é azionato dal sollevamento della leva.

Girando a sinistra = acqua calda.

Girando a destra = acqua fredda.

Dati tecnici

Questo miscelatore è dotato di serie del waterdimmer® (limitatore di flusso).

Potenza di erogaz. con waterdimmer:

7 l/min 0,3 MPa

Potenza di erogaz. senza waterdimmer:

12 l/min 0,3 MPa

Pressione d'uso: max. 1 MPa

Pressione d'uso consigliata: 0,1 – 0,5 MPa

Pressione di prova: 1,6 MPa

(1 MPa = 10 bar = 147 PSI)

Temp. dell'acqua calda consigliata: max 80° C

Temp. dell'acqua calda consigliata: 60° C

I miscelatori Hansgrohe possono venire usati con caldaie a "bassa pressione" se la pressione del flusso è almeno di 0,15 MPa.

Nel caso di problemi con lo scaldacqua oppure nel caso si desiderasse più erogazione, si può eliminare il waterdimmer® (limitatore di flusso 5a) dietro la valvola di aerazione.

Regolazione del limitatore di erogazione di acqua calde dei miscelatori monocomando, vedere pagina 8.

In combinazione con le caldaie istantanee, il limitatore di erogazione di acqua calda non è necessario.

Parti di ricambio vedi pagg. 5

1	maniglia	33091000
1.1	tappino	94191000
2	cappuccio	94192000
	Cappuccio oro	94192990
3	ghiera di fissaggio	94194000
4	cartuccia completa	92730000
5	rompigetto compl. (10)	13912000
	rompigetto compl. gold	94980990
	rompigetto compl. (6 l/min)	96788000
6	asta salterello	92620000
	asta salterello dorato ottica	92620990
7	set di fissaggio	96016000
8	raccordo flessibile	95001000
9	raccordo flessibile	97206000

Accessori speciali

X chiave per montaggio 58085000
(non compresi)

Segno di verifica

	DVGW	P-IX	SVGW	ACS	NF	WRAS	KIWA
33001000	X	P-IX 8388/IA	X			X	X
33002XXX	X	P-IX 8388/IA	X		X		X
33006000	X	P-IX 8388/IA	X				X
33007000							
33008000	X	P-IX 8388/IA	X		X		X
33011000							
33200XXX	X	P-IX 8388/IA	X			X	X
33202XXX	X	P-IX 8388/IA	X		X		X
33208000	X	P-IX 8388/IA	X		X		X

Limitatore di acqua calda: temperatura dell'acqua calda 60 C, temperatura dell'acqua fredda 10 C, pressione 0,3 MPa.

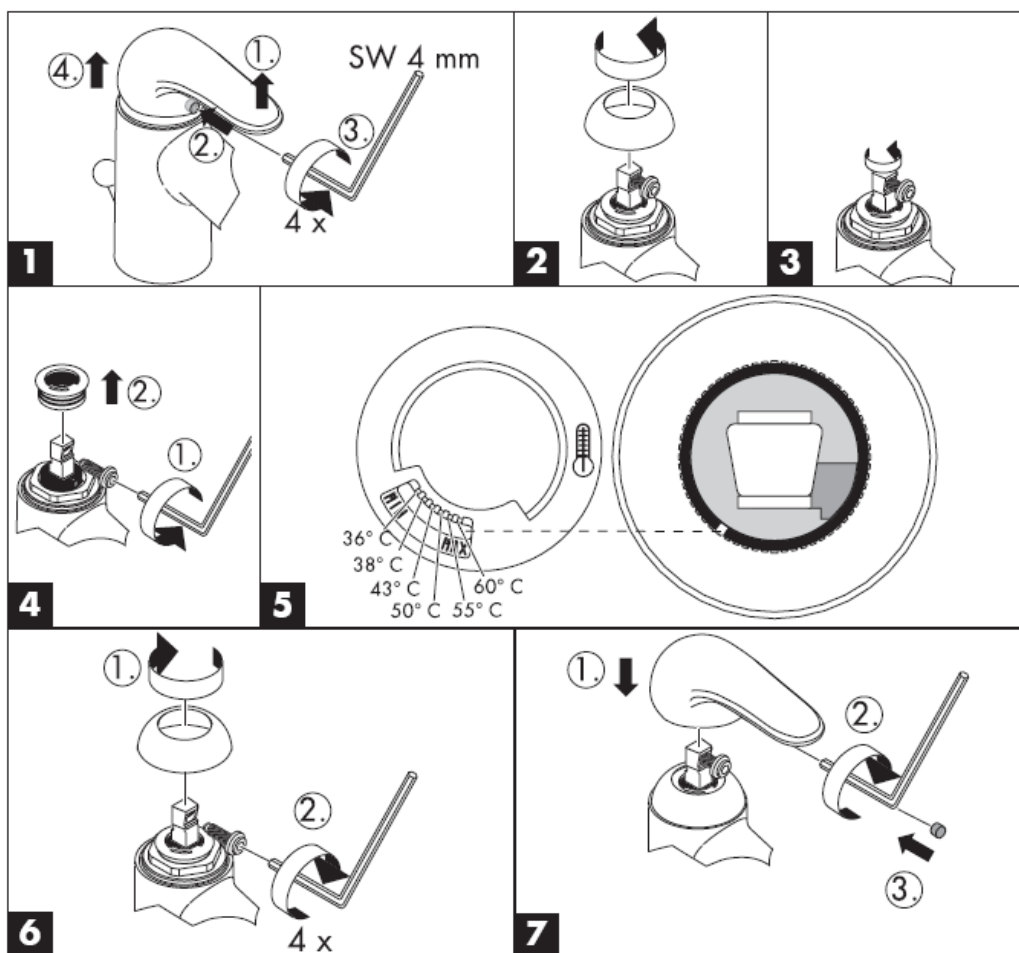

Pulitura

Con Rubit®, la funzione anticalcare manuale, i diffusori del getto possono essere liberati da calcare con un semplice strofinamento.



hansgrohe

Hansgrohe · Postfach 1145 · D-77761 Schiltach · Telefon +49 (0) 78 36/51-1282 · Telefax +49 (0) 7836/511440
E-Mail: info@hansgrohe.com · Internet: www.hansgrohe.com

05/2006
9.07956.04
Italiano

Instrucciones de montaje



Talis E

33001000/33002XXX/33006000
33007000/33008000/33011000



Talis E

33200XXX/33202XXX/33208000

hansgrohe

33001000

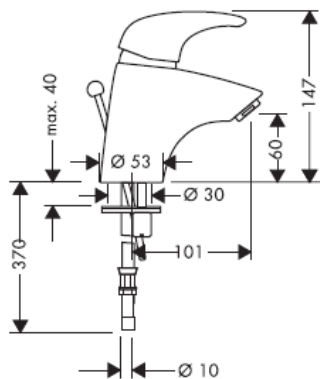

33200XXX

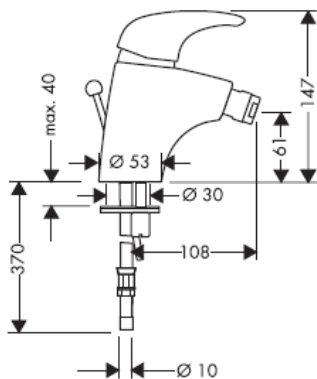

33002XXX

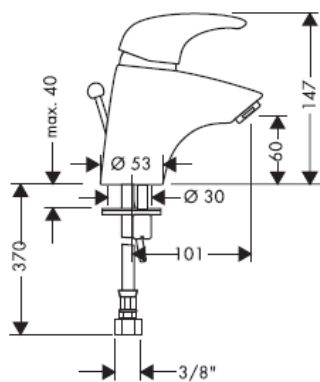

33202XXX

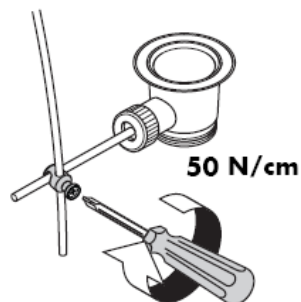
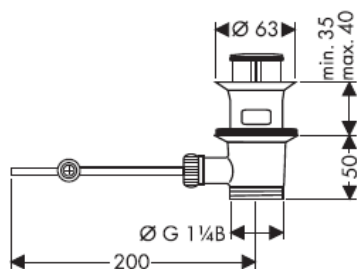
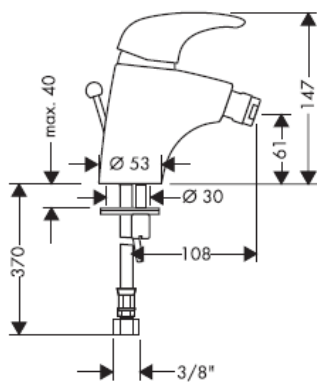

33008000

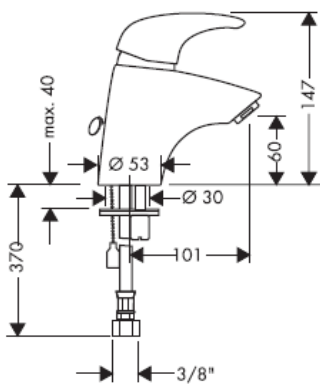

33208000

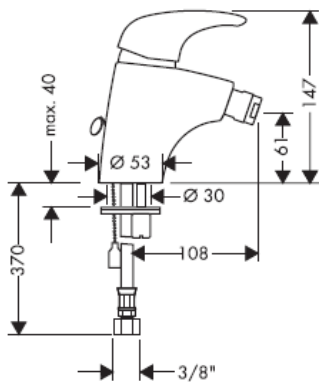

33006000

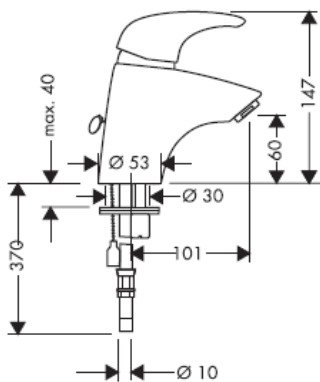

33007000

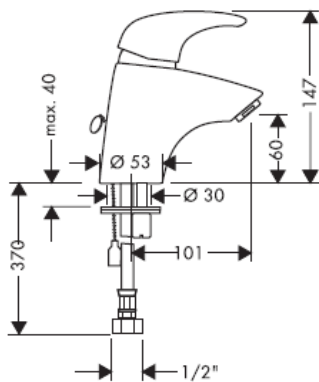

33011000

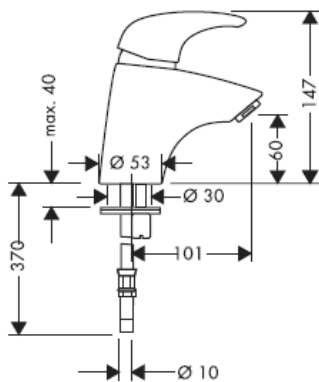

Montaje conexión flexible

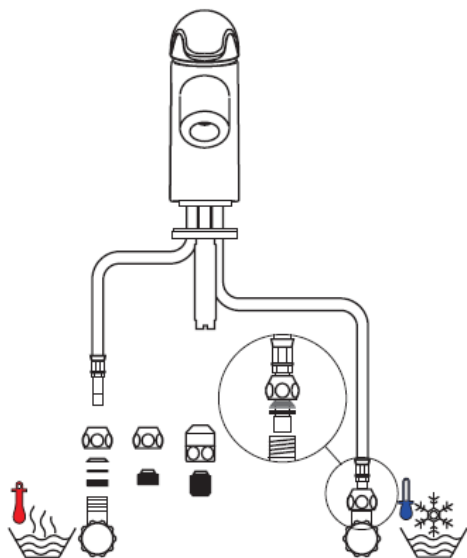
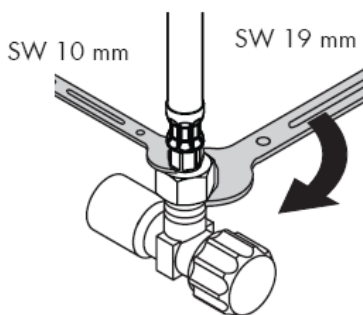
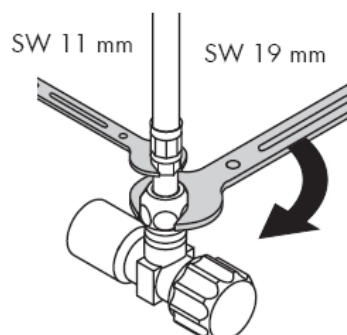
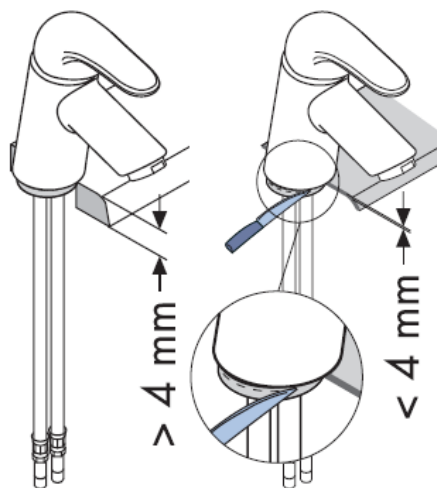
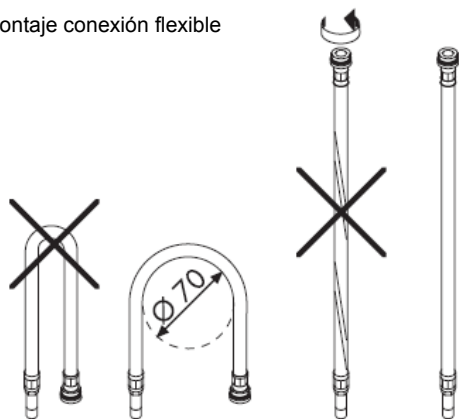

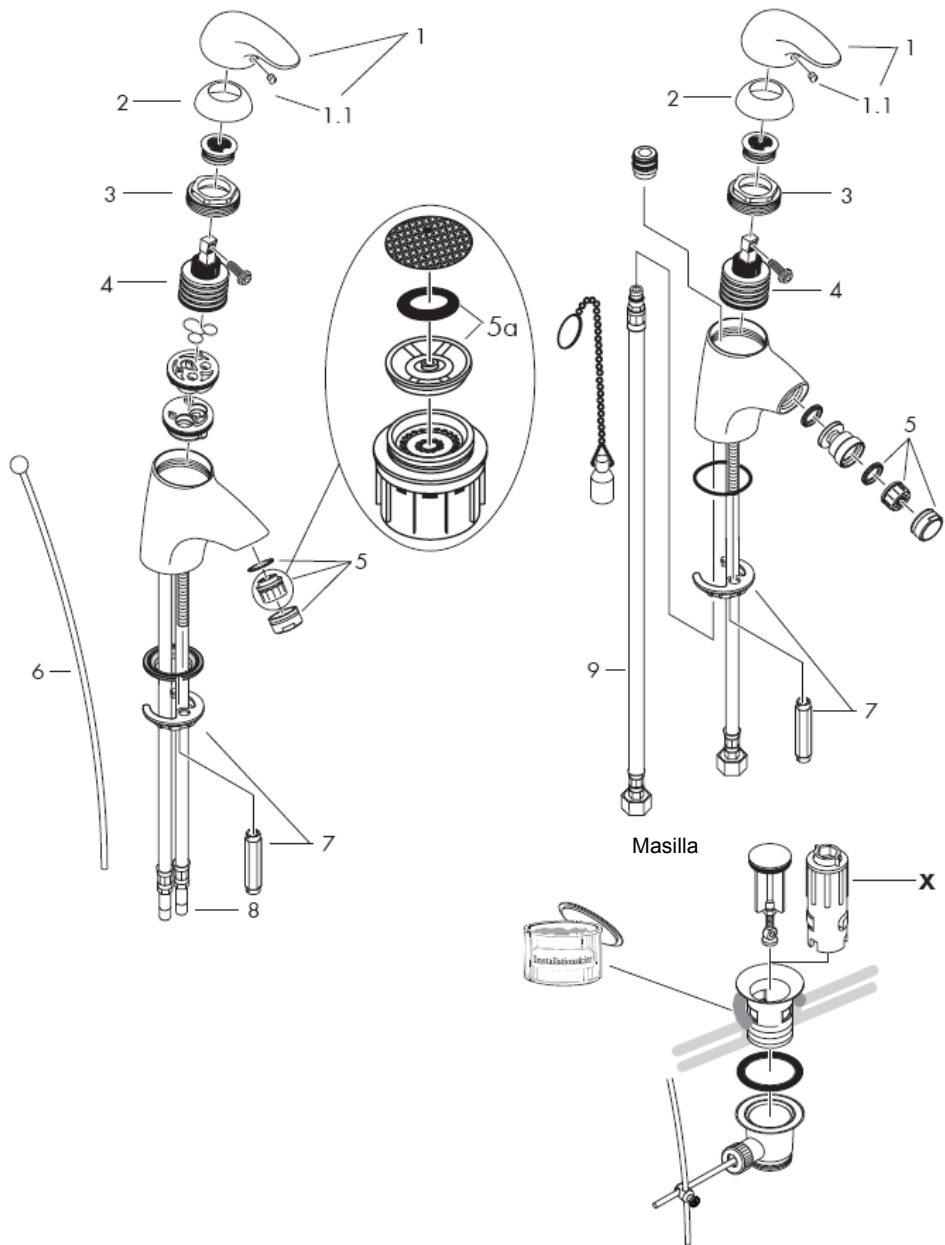

¡Atención! El grifo tiene que ser instalado, probado y testado, según las normas en vigor.

Montaje

- 1 Purgar las tuberías de afluencia.
- 2 Colocar la grifería en el lavabo / bide junto con el elemento intermedio de goma.
- 3 Poner el anillo de deslizamiento y la arandela metálica sobre la pieza roscada y apretar la tuerca.
- 4 Empalmar los tubos de unión con las llaves de escuadra.
- 5 Frío hacia la derecha, caliente hacia la izquierda.
- 6 33001000/32002XXX/33200XXX/
33202XXX: Unir el tirador con la válvula automática.

Grandes diferencias de presión entre los empalmes de agua fría y agua caliente deben equilibrarse.

Manejo

El mezclador se abre levantando la manecilla hacia arriba.

Giro hacia la izquierda = agua caliente,
giro hacia la derecha = agua fría.

Datos técnicos

Grifo con recuctor de caudal de serie Waterdimmer®.

Caudal máximo con waterdimmer:

7 l/min 0,3 MPa

Caudal máximo sin waterdimmer:

12 l/min 0,3 MPa

Presión en servicio: max. 1 MPa

Presión recomendada en servicio: 0,1 – 0,5 MPa

Presión de prueba: 1,6 MPa

(1 MPa = 10 bar = 147 PSI)

Temp. recomendada del agua caliente: max 80°

C

Temp. recomendada del agua caliente: 60° C

Los mezcladores Hansgrohe pueden ser utilizado junto con calentadores continuos de agua que sean manejados de manera hidráulica o térmica, siempre que la presión del caudal ascienda a un mínimo de 0,15 MPa.

En caso de problemas con el calentador instantáneo o cuando se deseen más caudal de agua puede quitarse el waterdimmer® (limitador del caudal 5a), situado detrás del aireador.

Mezclador monomando con limitación del caudal de agua caliente; ajuste ver pagina 8.

En combianción con calentadores instantáneos no es necesario una limitación del caudal de agua caliente.

Repuestos ver página 5

1	Mando	33091000
1.1	Tapón	94191000
2	Florón	94192000
	Florón color oro	94192990
3	Tuerca	94194000
4	Cartucho completo	92730000
5	Aireador completo (10)	13912000
	Aireador completo gold	94980990
	Aireador completo (6 l/min)	96788000
6	Tirador	92620000
	Tirador oro óptica	92620990
7	Set de fijación	96016000
8	Conexión flexible	95001000
9	Conexión flexible	97206000

Opcional

X Llave de montaje 58085000
(no incluido)

Español

Marca de verificación

	DVGW	P-IX	SVGW	ACS	NF	WRAS	KIWA
33001000	X	P-IX 8388/IA	X			X	X
33002XXX	X	P-IX 8388/IA	X		X		X
33006000	X	P-IX 8388/IA	X				X
33007000							
33008000	X	P-IX 8388/IA	X		X		X
33011000							
33200XXX	X	P-IX 8388/IA	X			X	X
33202XXX	X	P-IX 8388/IA	X		X		X
33208000	X	P-IX 8388/IA	X		X		X

Limitación del agua caliente: temperature del agua caliente 60 C, temperatura del agua fria 10 C, presión dinámica 0,3 MPa.

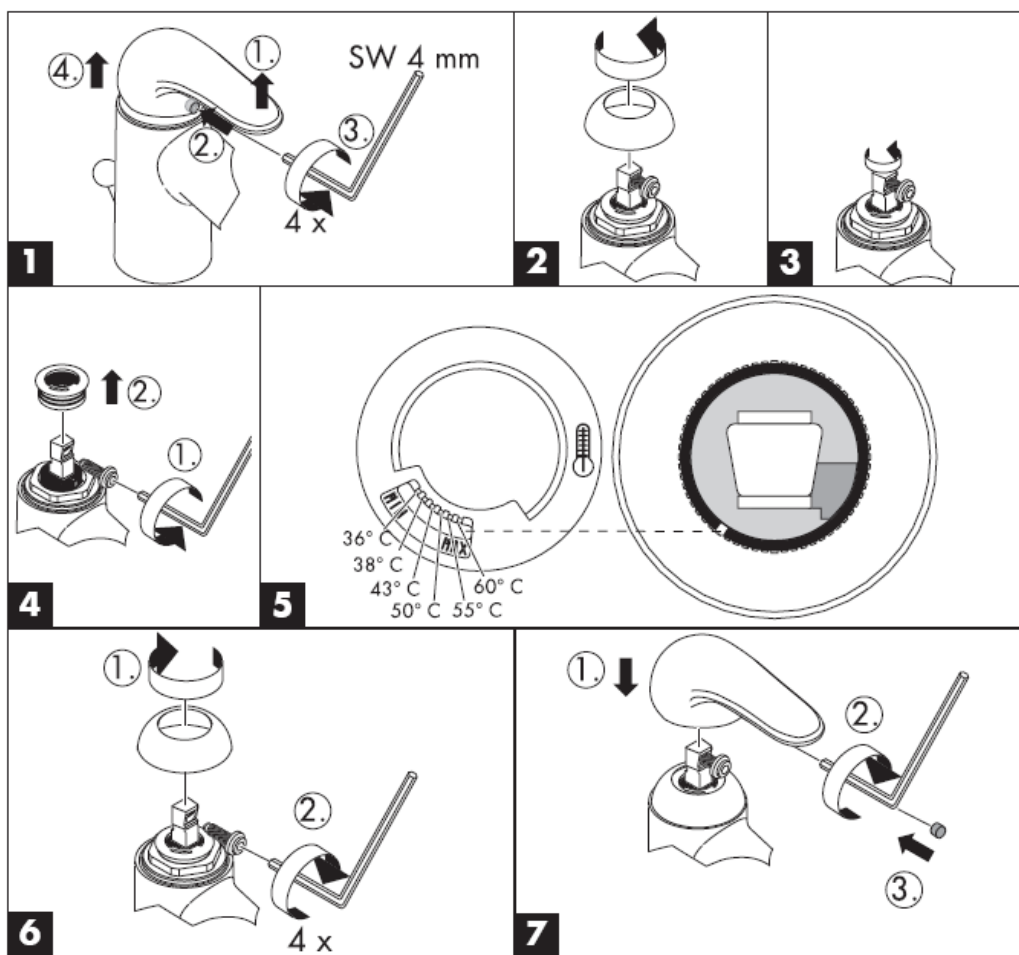

Limpiar

Rubit®, la función de limpieza manual, permite quitar la cal simplemente frotando los ejectores.



hansgrohe

Hansgrohe · Postfach 1145 · D-77761 Schiltach · Telefon +49 (0) 78 36/51-1282 · Telefax +49 (0) 7836/511440
E-Mail: info@hansgrohe.com · Internet: www.hansgrohe.com

05/2006
9.07956.04
Español

Handleiding



Talis E

33001000/33002XXX/33006000
33007000/33008000/33011000



Talis E

33200XXX/33202XXX/33208000

hansgrohe

33001000

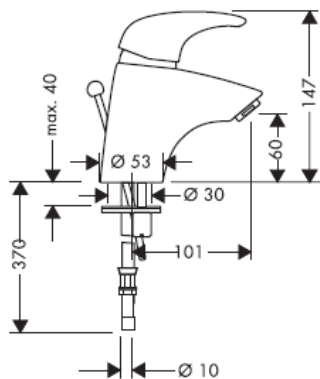

33200XXX

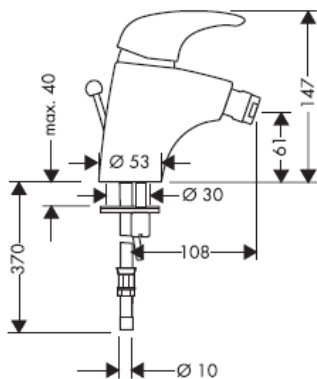

33002XXX

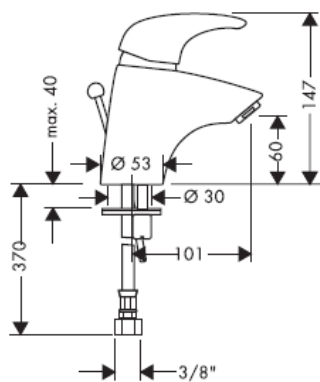

33202XXX

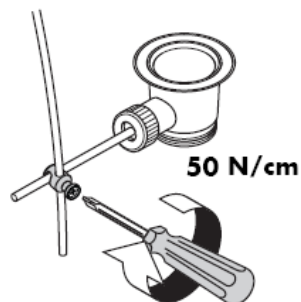
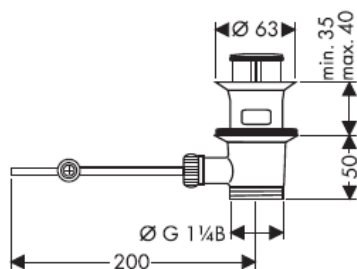
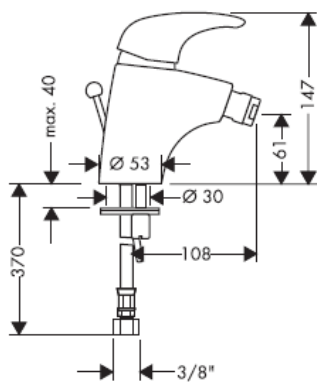

33008000

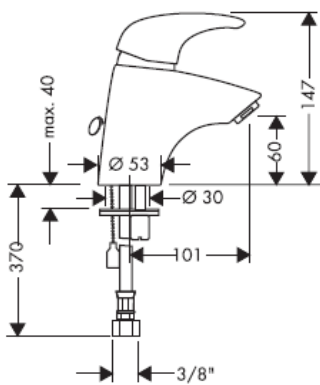

33208000

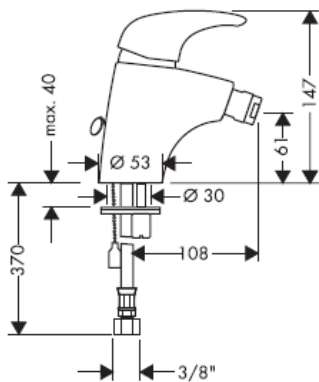

33006000

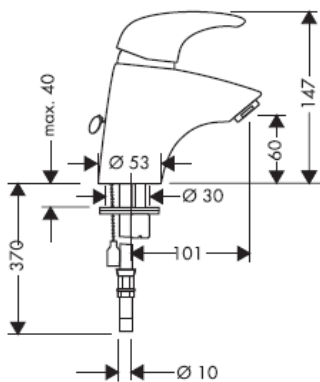

33007000

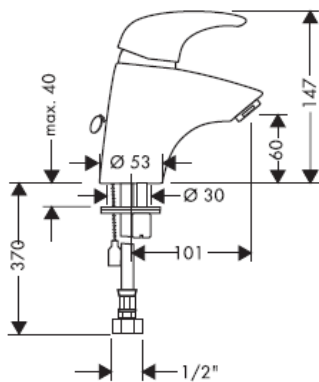

33011000

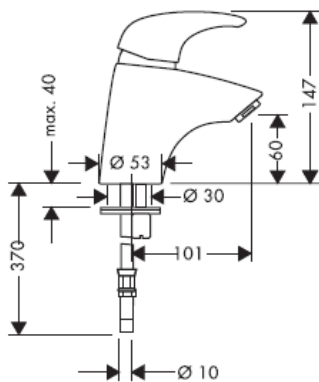

Montage aansluitingslangen

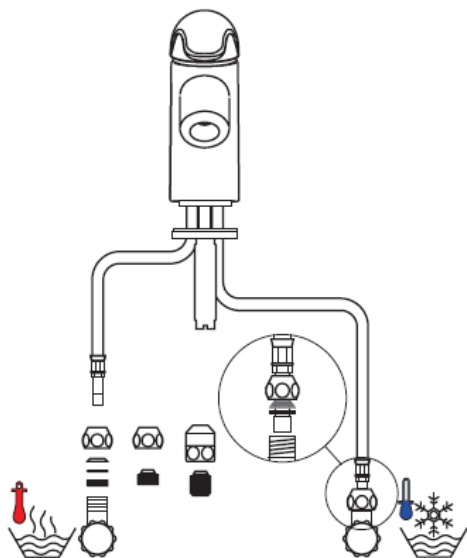
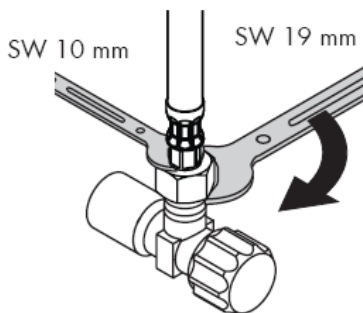
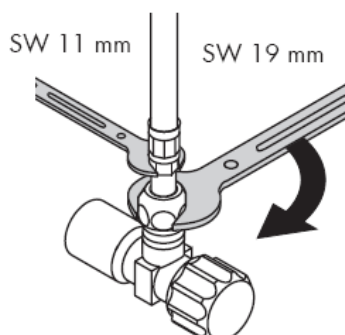
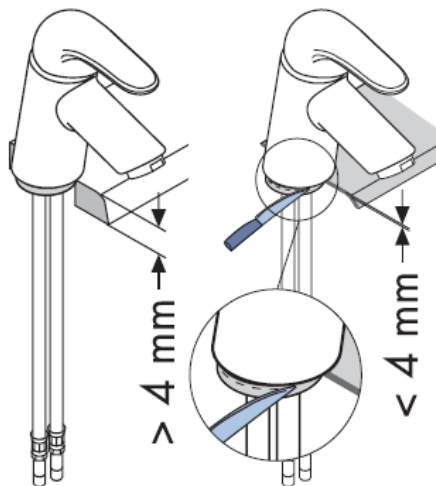
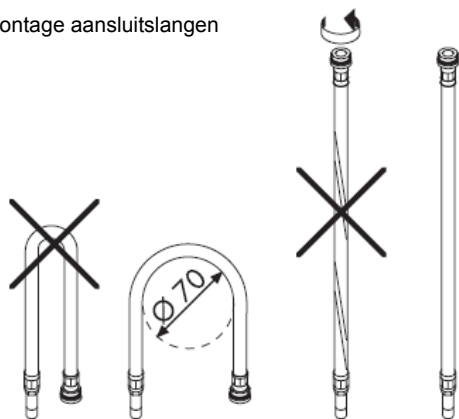

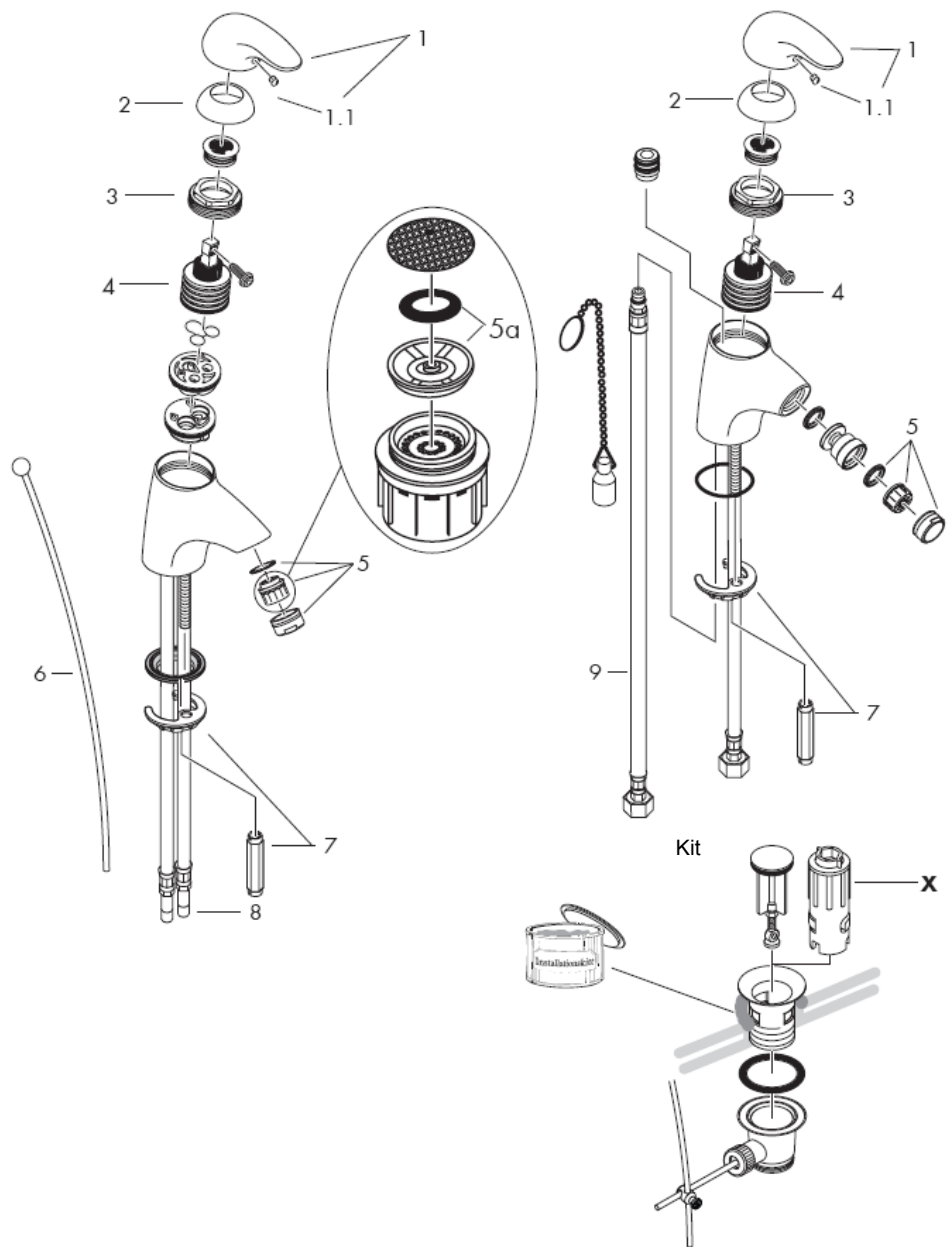

Attentie! Leidingen doorspoelen volgens Norm. De mengkraan vervolgens monteren en controleren!

Montage

- 1 Toevoerleidingen vakkundig doorspoelen.
- 2 Kraan met afdichtingsring in de wastafel / bidet monteren en schroeve aandraaien.
- 3 Kraan met afdichtingsring in de wastafel monteren en schroeve aandraaien. Aansluitslangen aan hoekstopkranen aansluiten.
- 4 Aansluitpijpjes aan hoekstopkranen aansluiten.
- 5 Links = warm water, rechts = koud water.
- 6 33001000/32002XXX/33200XXX/
33202XXX: Trekstang aan de afvoerplug bevestigen.

Grote drukverschillen tussen de kouden warm wateraansluitingen dienen vermeden te worden.

Bediening

Door het bedienen van de beugelgreep wordt de mengkraan geopend.

Naar links bewegen = warm water,
naar rechts = koud water.

Technische gegevens

Kraan met Waterdimmer® (doorstroombegrenzer).

Doorstroomcapaciteit met waterdimmer:
7 l/min 0,3 MPa

Doorstroomcap. zonder waterdimmer:
12 l/min 0,3 MPa

Werkdruk: max. max. 1 MPa

Aanbevolen werkdruk: 0,1 – 0,5 MPa

Getest bij: 1,6 MPa

(1 MPa = 10 bar = 147 PSI)

Aanbevolen warm water temp.: max 80° C

Aanbevolen warm water temp.: 60° C

Hansgrohe ééngreepsmengkranen kunnen samen met hydraulisch en thermisch gestuurde geisers gebruikt worden indien de uitstroomdruk min. 0,15 MPa bedraagt.

Bij problemen met doorstroomtoestellen of wanneer een grotere waterdoorstroom gewenst is, kan men de waterdimmer® (doorstroomregelaar 5a) die achter de perlator is gemonteerd, eenvoudig verwijderen.

Eéngreepsmengkranen met warmwaterbegrenzing, instelling zie blz. 8. In combinatie met geisers is een warmwaterbegrenzing niet noodzakelijk.

Service onderdelen zie blz. 5

1	greep	33091000
1.1	greepstopje	94191000
2	afdekkap	94192000
	afdekkap goud	94192990
3	moer	94194000
4	kardoes kompl.	92730000
5	perlator kompl. (10)	13912000
	perlator kompl. gold	94980990
	perlator kompl. (6 l/min)	96788000
6	trekstang	92620000
	trekstang verguld-look	92620990
7	schachtbevestigingsset	96016000
8	aansluitslang	95001000
9	aansluitslang	97206000

Toebehoren

X afvoer montagesleutel 58085000
(Wordt niet meegeleverd)

Nederlands

Keurmerk

	DVGW	P-IX	SVGW	ACS	NF	WRAS	KIWA
33001000	X	P-IX 8388/IA	X			X	X
33002XXX	X	P-IX 8388/IA	X		X		X
33006000	X	P-IX 8388/IA	X				X
33007000							
33008000	X	P-IX 8388/IA	X		X		X
33011000							
33200XXX	X	P-IX 8388/IA	X			X	X
33202XXX	X	P-IX 8388/IA	X		X		X
33208000	X	P-IX 8388/IA	X		X		X

Warmwaterbegrenzing: Warmwatertemperatuur 60 C, Koudwatertemperatuur 10 C, stroomdruk 0,3 MPa.

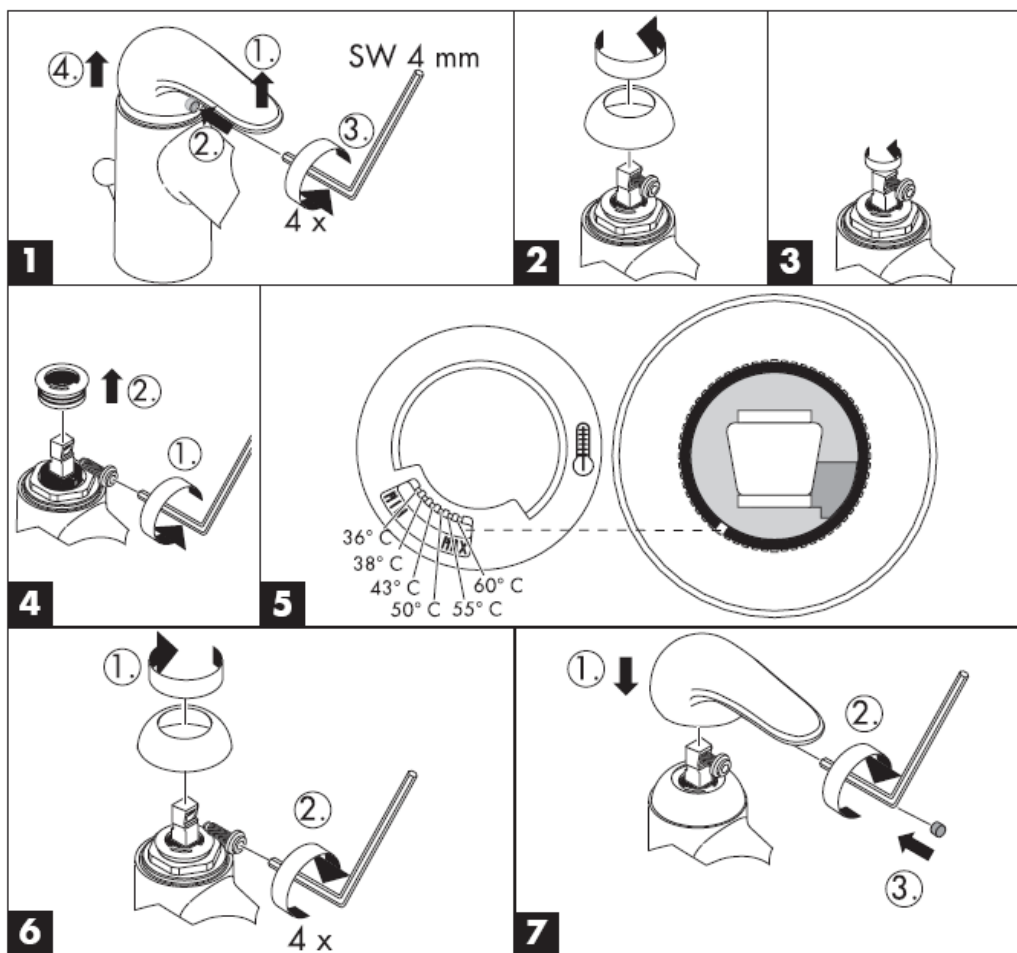

Reinigen

Met Rubit®, de handmatige reinigingsfunctie, kunnen de straalopeningen door het met de hand wegwrijven van kalk, gereinigd worden.



hansgrohe

Hansgrohe · Postfach 1145 · D-77761 Schiltach · Telefon +49 (0) 78 36/51-1282 · Telefax +49 (0) 7836/511440
E-Mail: info@hansgrohe.com · Internet: www.hansgrohe.com

05/2006
9.07956.04
Nederlands

Monteringsvejledning



Talis E

33001000/33002XXX/33006000
33007000/33008000/33011000



Talis E

33200XXX/33202XXX/32208000

hansgrohe

33001000

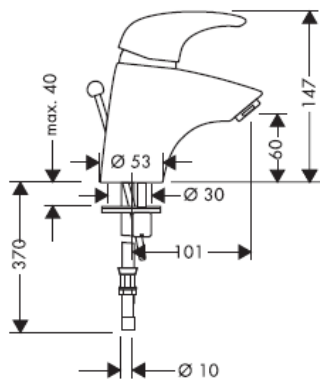

33200XXX

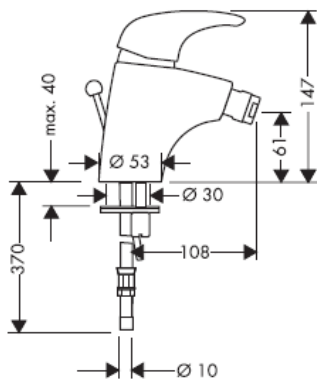

33002XXX

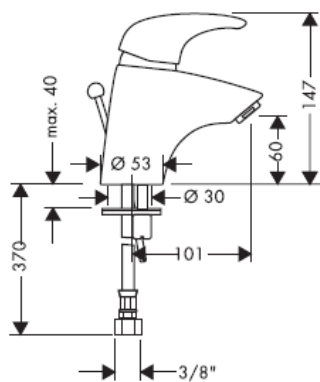

33202XXX

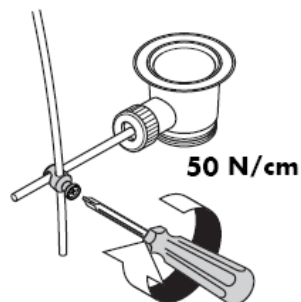
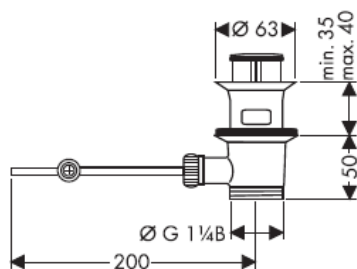
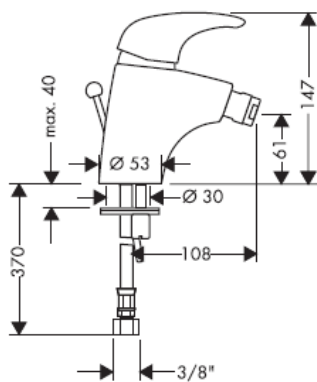

33008000

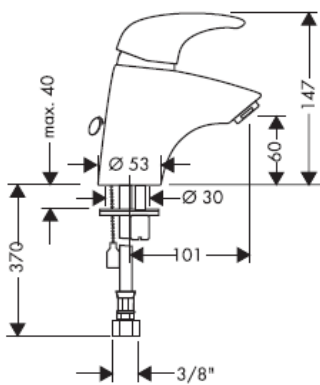

33208000

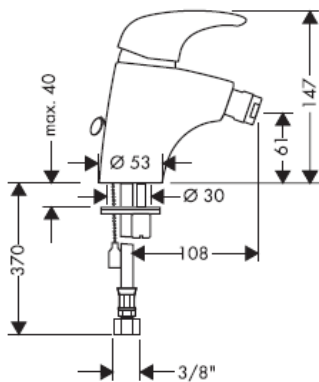

33006000

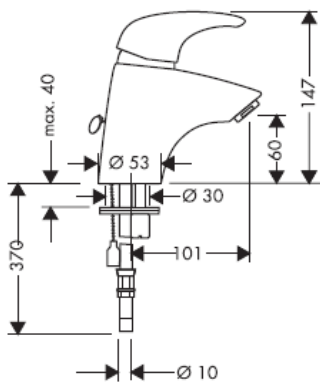

33007000

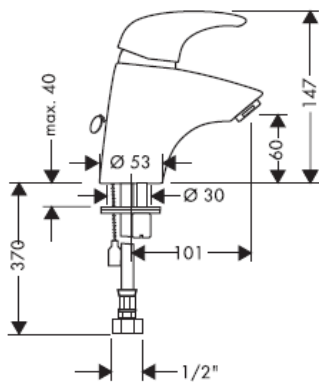

33011000

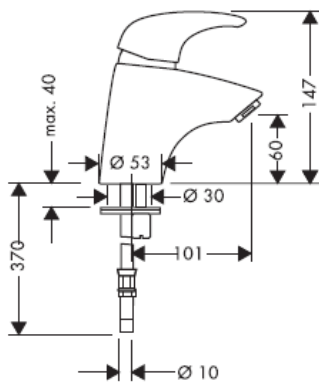

Montering tilslutningslangerne

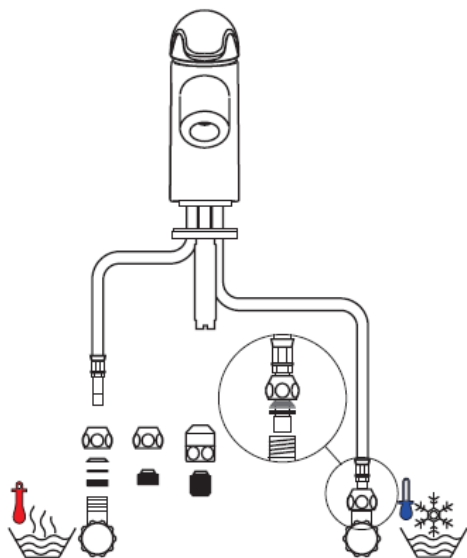
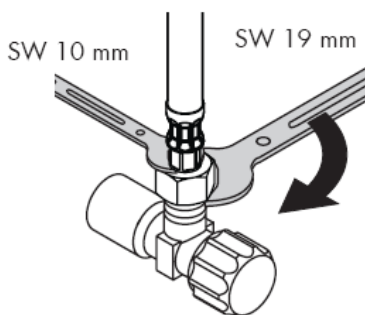
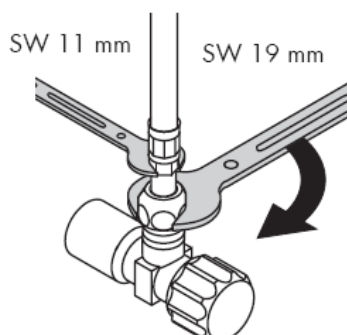
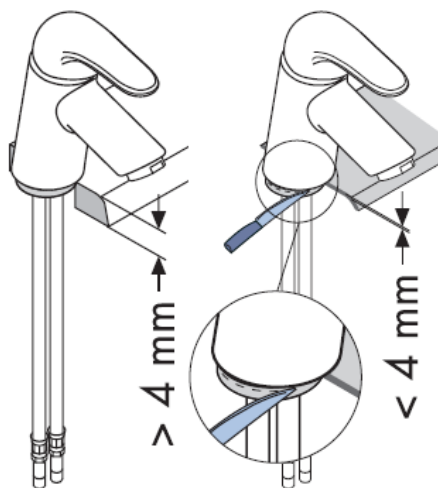
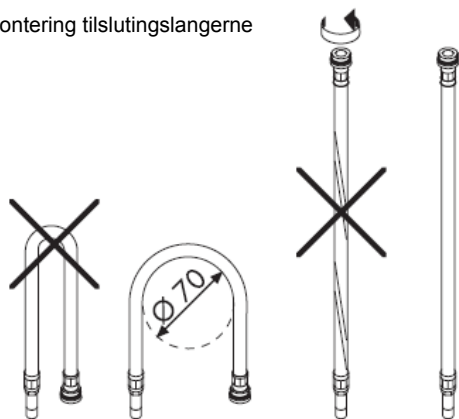

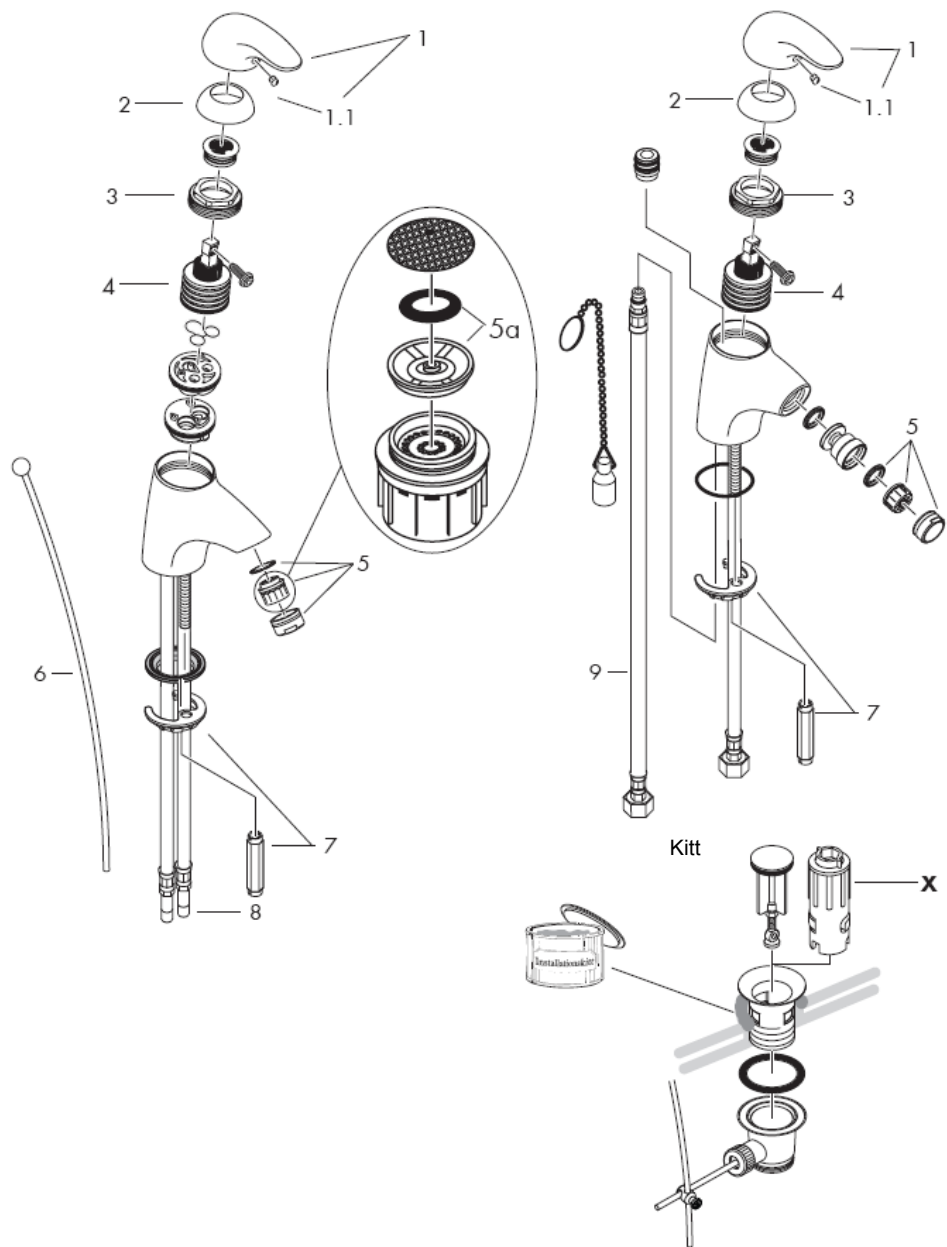

Advarsel! Ifølge gældende regler, skal armaturet monteres, skylles igennem og afprøves.

Montering

- 1 Skyl tilførselsledningene grundig.
- 2 Montér armaturen i servanten / bidéet med mellemlagsskive.
- 3 Skyd skive og mellemlagsskive over gevindstussen og trekk til skrueerne.
- 4 Kobbelt tilslutningsslange til stopventilerne.
- 5 Koldt højre, varmt venstre.
- 6 33001000/32002XXX/33200XXX/
33202XXX: Montér løftop-stangen til afløbsventilen.

Større trykforskelle mellem koldt og varmt vand bør udjævnes.

Brugsanvisning

Ved at hæve bøjlegrebet åbnes for vandet.
Drejning til venstre = varmt vand,
drejning til højre = koldt vand.

Tekniske data

Armaturet er forsynet med Waterdimmer® (gennemstrømningsbegrænser).

Gennemstrømningskap. med waterdimmer:
7 l/min 0,3 MPa

Gennemstrømningskap. uden waterdimmer:
12 l/min 0,3 MPa

Driftstryk: max. 1 MPa

Anbefalet driftstryk: 0,1 – 0,5 MPa

Prøvetryk: 1,6 MPa

(1 MPa = 10 bar = 147 PSI)

Anbefalet varmtvandstemperatur: max 80° C

Anbefalet varmtvandstemperatur: 60° C

Hansgrohe etgrebsarmaturer kan anvendes i forbindelse med hydraulisk- og termiskstyrede gennemstrømningsvandvarmere ved et vandtryk på 0,15 MPa.

Ved problemer med gennemløbsvandvarmer eller hvis der ønskes mere vandgennemstrømning, kan waterdimmer® (gennemstrømningsbegrænseren 5a), der sidder i perlatoren, fjernes.

Etgrebsarmaturer med varmtvandsbegrænsning, justering se side 8.

I forbindelse med gennemstrømningsvandvarmer er en varmtvandsbegrænsning ikke nødvendig.

Reserve dele se s. 5

1	Greb	33091000
1.1	Dækknap til greb	94191000
2	Dækskive	94192000
	Dækskive guld	94192990
3	Møtrik	94194000
4	Indmad	92730000
5	Perlator kpl. (10)	13912000
	perlator kompl. gold	94980990
	Perlator kpl. (6 l/min)	96788000
6	Løftop-stang	92620000
	Løftop-stang Guld optic	92620990
7	Festedel	96016000
8	Tilslutningsslange	95001000
9	Tilslutningsslange	97206000

Specialtilbehør

X Monteringsnøgle-sæt 58085000
(leveres ikke)

Dansk

Godkendelse

	DVGW	P-IX	SVGW	ACS	NF	WRAS	KIWA
33001000	X	P-IX 8388/IA	X			X	X
33002XXX	X	P-IX 8388/IA	X		X		X
33006000	X	P-IX 8388/IA	X				X
33007000							
33008000	X	P-IX 8388/IA	X		X		X
33011000							
33200XXX	X	P-IX 8388/IA	X			X	X
33202XXX	X	P-IX 8388/IA	X		X		X
33208000	X	P-IX 8388/IA	X		X		X

Varmtvandsbegrænsning: Varmtvandstemperatur 60o C, koldtvandstemperatur 10o C, vandtryk 0,3 MPa.

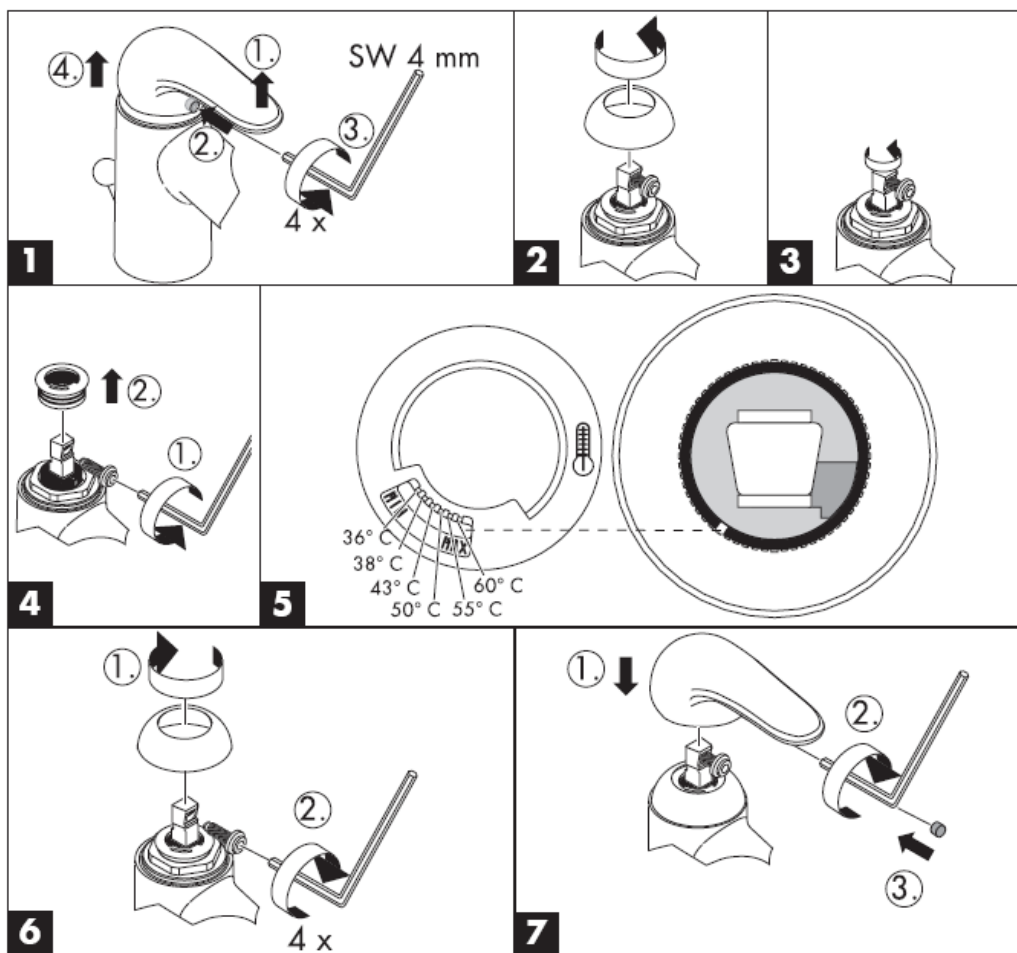

Rengøring

Med Rubit®, den manuelle rengøringsfunktion kan strålekanalerne let renses for kalk - der skal blot gnubbes!



hansgrohe

Hansgrohe · Postfach 1145 · D-77761 Schiltach · Telefon +49 (0) 78 36/51-1282 · Telefax +49 (0) 7836/511440
E-Mail: info@hansgrohe.com · Internet: www.hansgrohe.com

05/2006
9.07956.04
Dansk

Manual de Instalación



Talis E

33001000/33002XXX/33006000
33007000/33008000/33011000



Talis E

33200XXX/33202XXX/32208000

hansgrohe

33001000

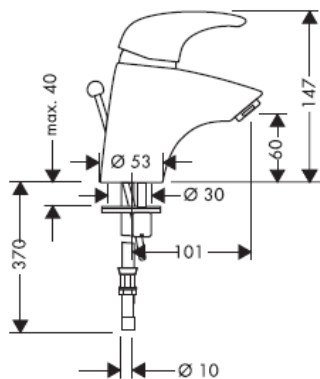

33200XXX

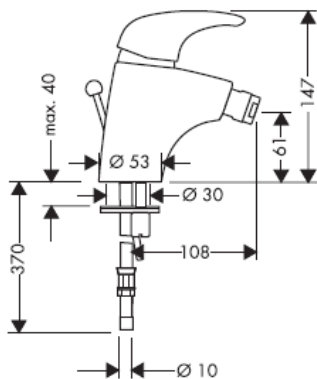

33002XXX

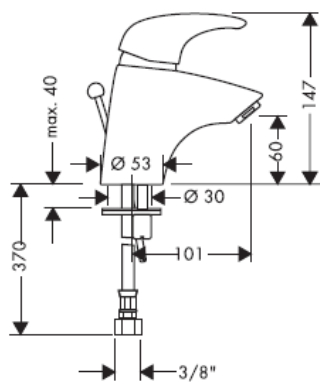

33202XXX

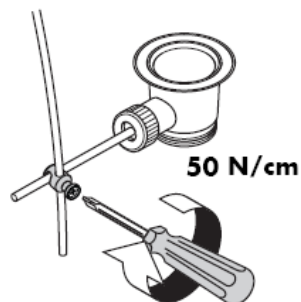
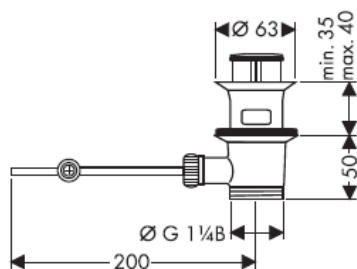
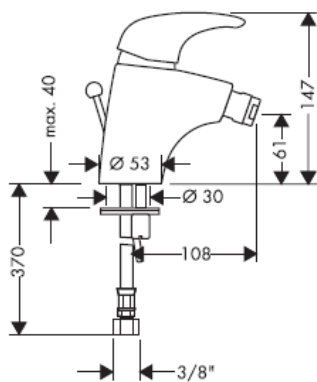

33008000

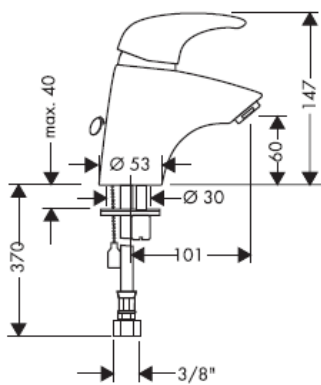

33208000

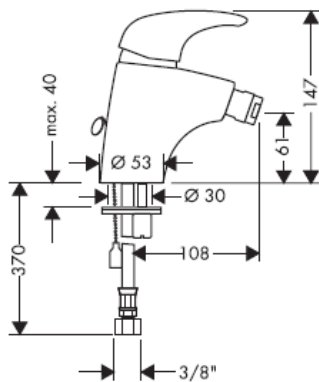

33006000

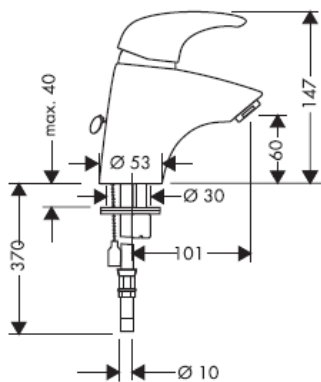

33007000

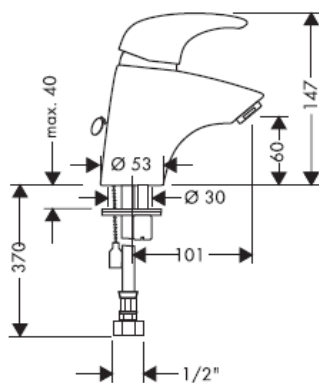

33011000

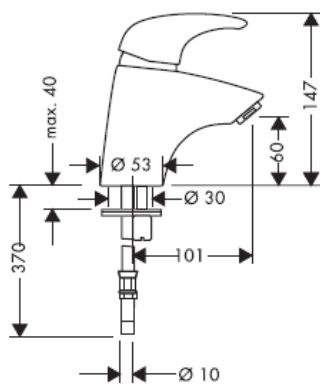

Montagem tubo flexível

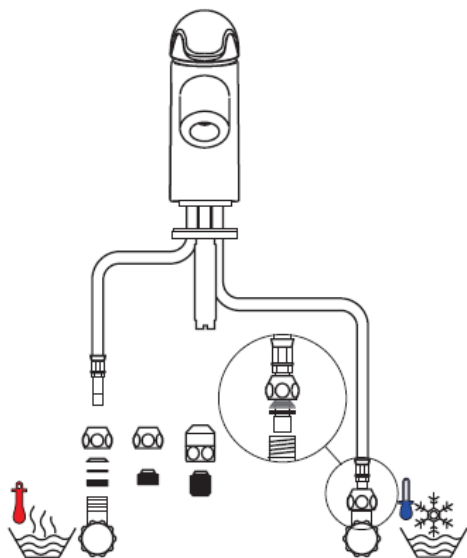
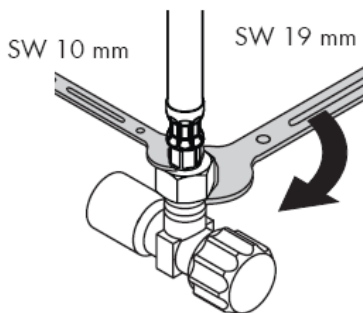
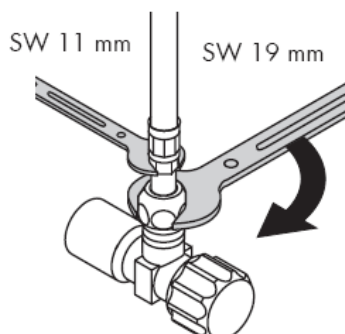
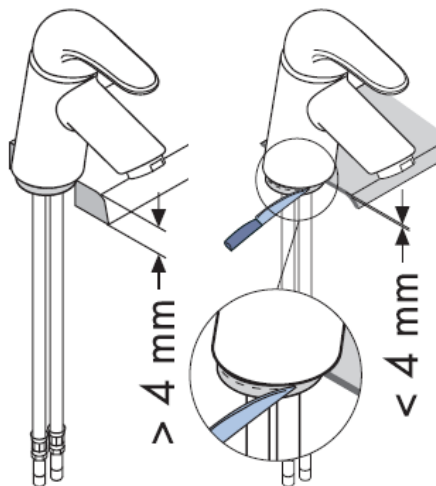
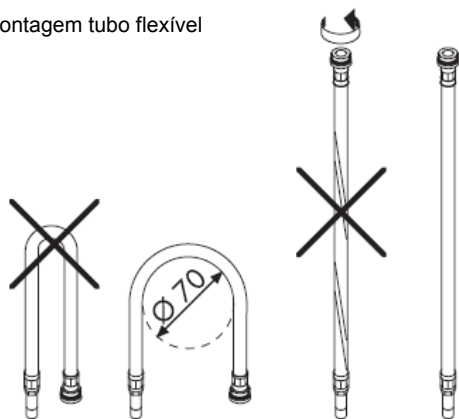

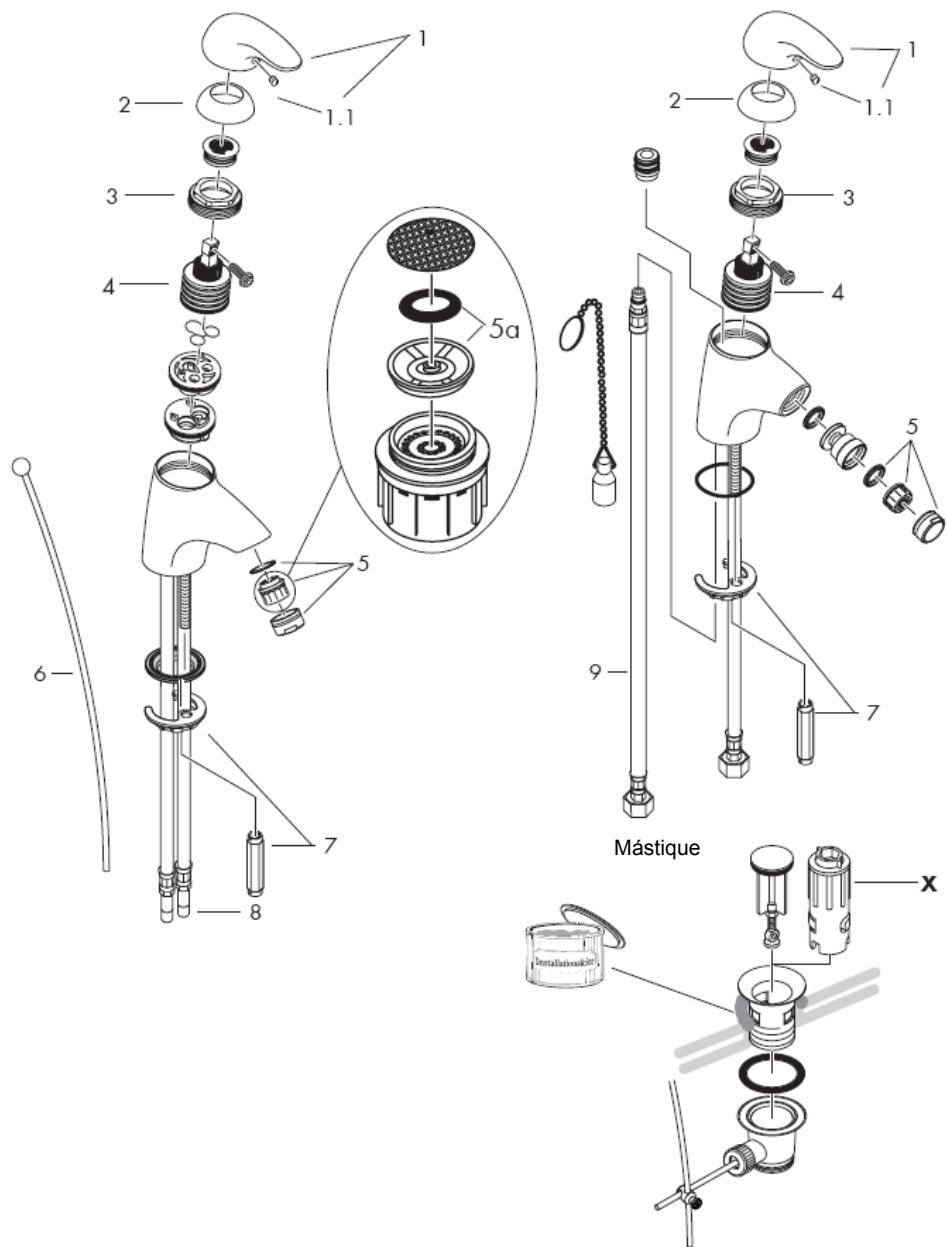

Atenção! A misturadora deve ser instalada, purgada e testada de acordo com as normas em vigor!

Montagem

- 1 Purgue a canalização.
- 2 Colocar a misturadora com o vedante no lavatório / bidé.
- 3 Enfiar os vedantes e a porca de aperto e apertar as porcas.
- 4 Ligar os tubos de alimentação da misturadora às torneiras de esquadria.
- 5 Fria à direita - quente à esquerda.
- 6 33001000/32002XXX/33200XXX/
33202XXX: Ligar a vareta à alavanca da válvula automática.

Grandes diferenças entre as pressões das águas quente e fria devem ser compensadas.

Funcionamento

A misturadora é aberta levantando o manípulo de alavanca.

Rodando para a esquerda = água quente.

Rodando para a direita = água fria.

Dados Técnicos

Misturadoras produzidas em série com Waterdimmer® (limitador de caudal).

Caudal com waterdimmer:

7 l/min 0,3 MPa

Caudal sem waterdimmer:

12 l/min 0,3 MPa

Pressão de funcionamento: max. 1 MPa

Pressão de func. recomendada: 0,1 – 0,5 MPa

Pressão testada: 1,6 MPa

(1 MPa = 10 bar = 147 PSI)

Temp. água quente recomendada: max 80° C

Temp. água quente recomendada: 60° C

As misturadoras monocomando Hansgrohe podem ser utilizadas com esquentadores (de controlo térmico ou hidráulico) desde que a pressão de utilização seja, no mínimo, de 0,15 MPa.

Neste caso o waterdimmer® (limitador de caudal 5a) existente por trás do emulsor deverá ser retirado.

Misturadora monocomando equipada com limitador de temperatura (vide pág.8).

Em combinação com caldeira ou esquentador instantâneo o limitador de água quente não se aplica.

Peças de substituição ver página 5

1	Manípulo	33091000
1.1	Tampa de parafuso	94191000
2	Espelho	94192000
	Espelho, ouro	94192990
3	Porca	94194000
4	Cartucho (completo)	92730000
5	Emulsor compl. (10)	13912000
	Emulsor compl. gold	94980990
	Emulsor compl. (6 l/min)	96788000
6	Vareta	92620000
	Vareta ouro ótica	92620990
7	Porca de fixação	96016000
8	Tubo flexível	95001000
9	Tubo flexível	97206000

Acessórios especiais

X chave especial 58085000
(não vem incluído)

Português

Marca de controlo

	DVGW	P-IX	SVGW	ACS	NF	WRAS	KIWA
33001000	X	P-IX 8388/IA	X			X	X
33002XXX	X	P-IX 8388/IA	X		X		X
33006000	X	P-IX 8388/IA	X				X
33007000							
33008000	X	P-IX 8388/IA	X		X		X
33011000							
33200XXX	X	P-IX 8388/IA	X			X	X
33202XXX	X	P-IX 8388/IA	X		X		X
33208000	X	P-IX 8388/IA	X		X		X

Limitador de água quente: Temperatura da água quente 60 C, Temperatura da água fria 10 C, Pressão 0,3 MPa.

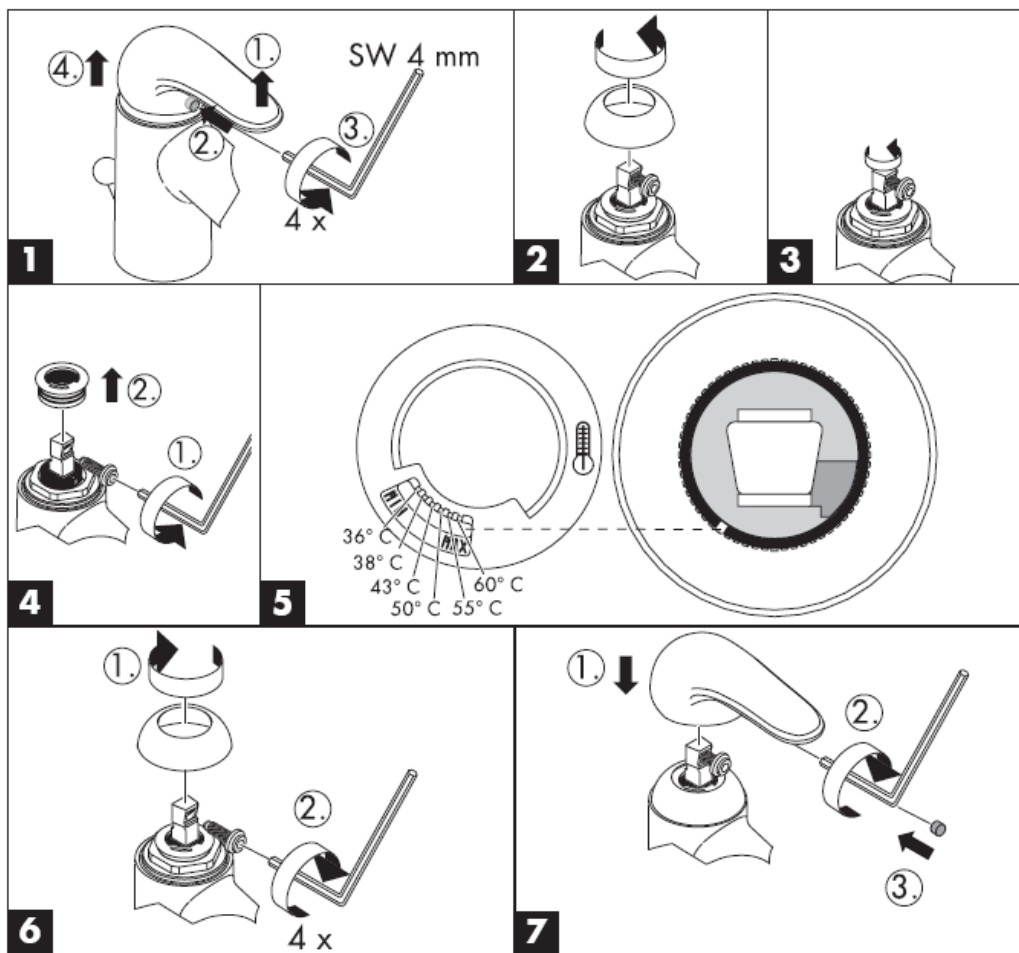

Limpeza

O sistema de limpeza Rubit® requer apenas uma ligeira passagem com a mão para remover os depósitos de calcário do emulsor.



hansgrohe

Hansgrohe · Postfach 1145 · D-77761 Schiltach · Telefon +49 (0) 78 36/51-1282 · Telefax +49 (0) 7836/511440
E-Mail: info@hansgrohe.com · Internet: www.hansgrohe.com

05/2006
9.07956.04
Português

Instrukcija montažu



Talis E

33001000/33002XXX/33006000
33007000/33008000/33011000



Talis E

33200XXX/33202XXX/32208000

hansgrohe

33001000

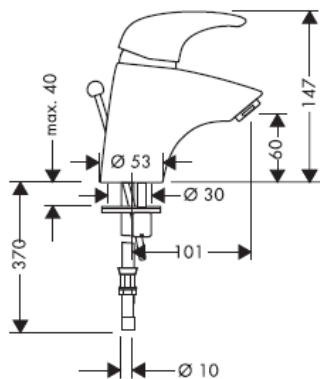

33200XXX

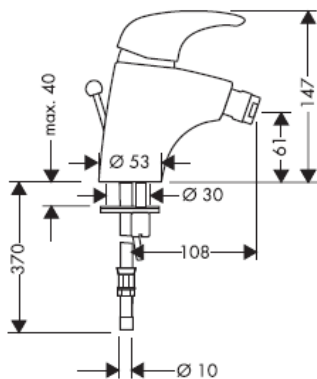

33002XXX

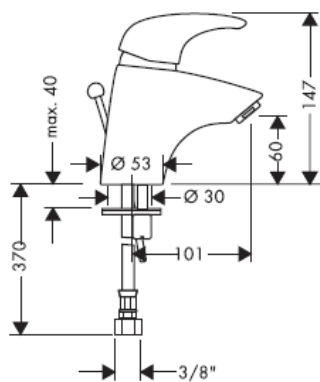

33202XXX

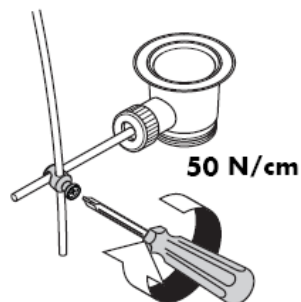
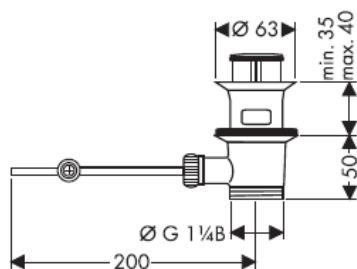
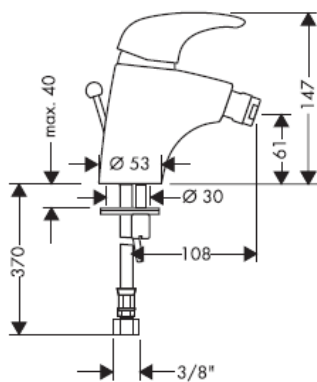

33008000

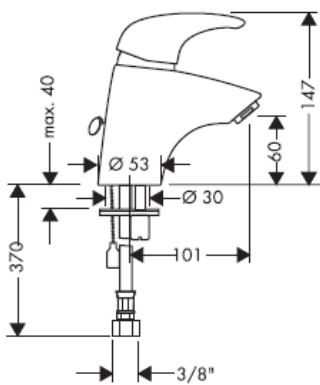

33208000

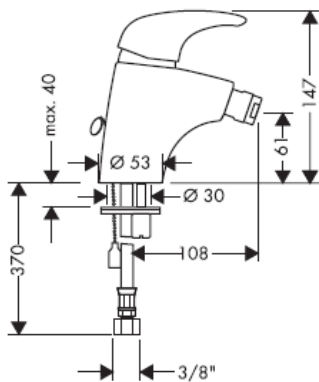

33006000

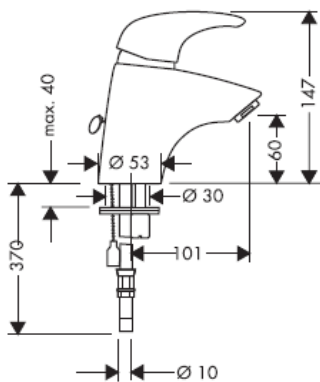

33007000

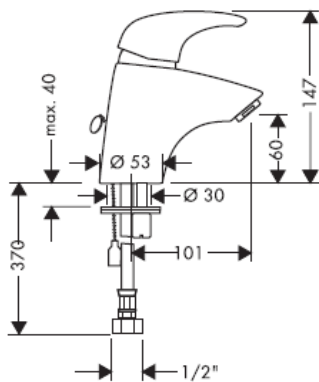

33011000

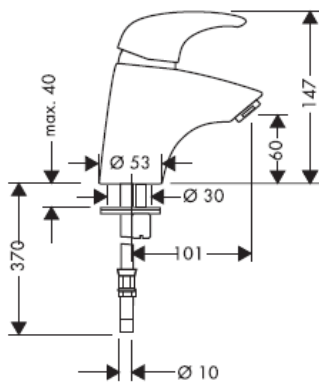

Montaż węży przyłączeniowych

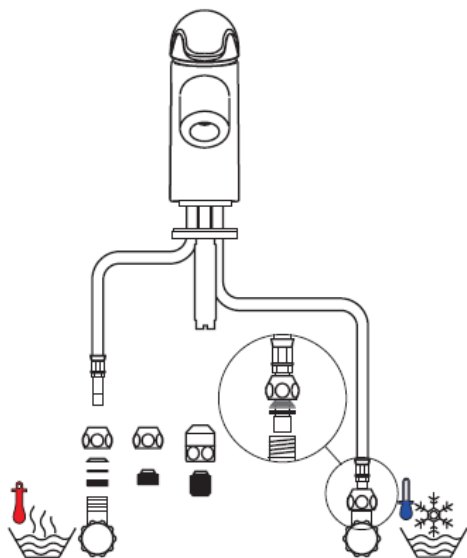
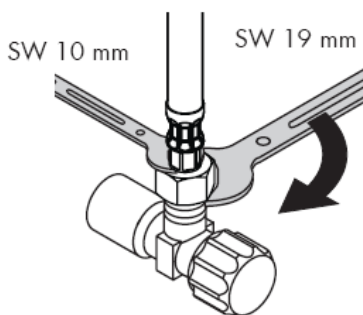
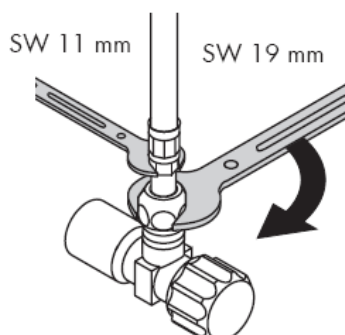
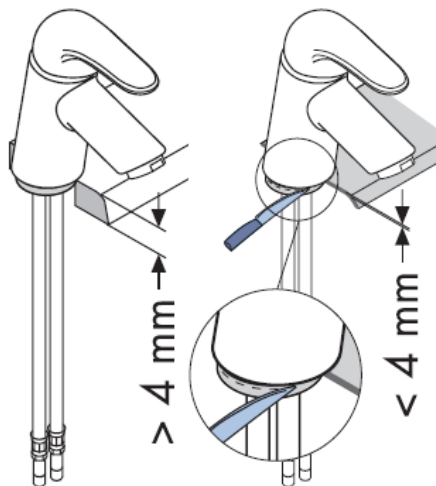
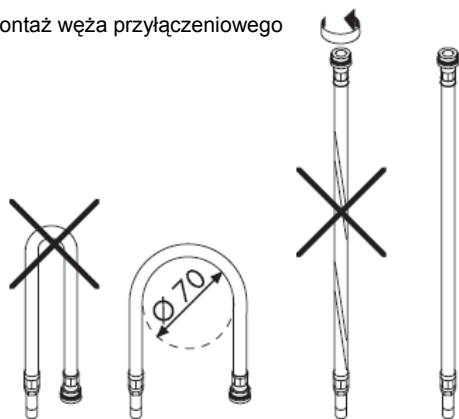

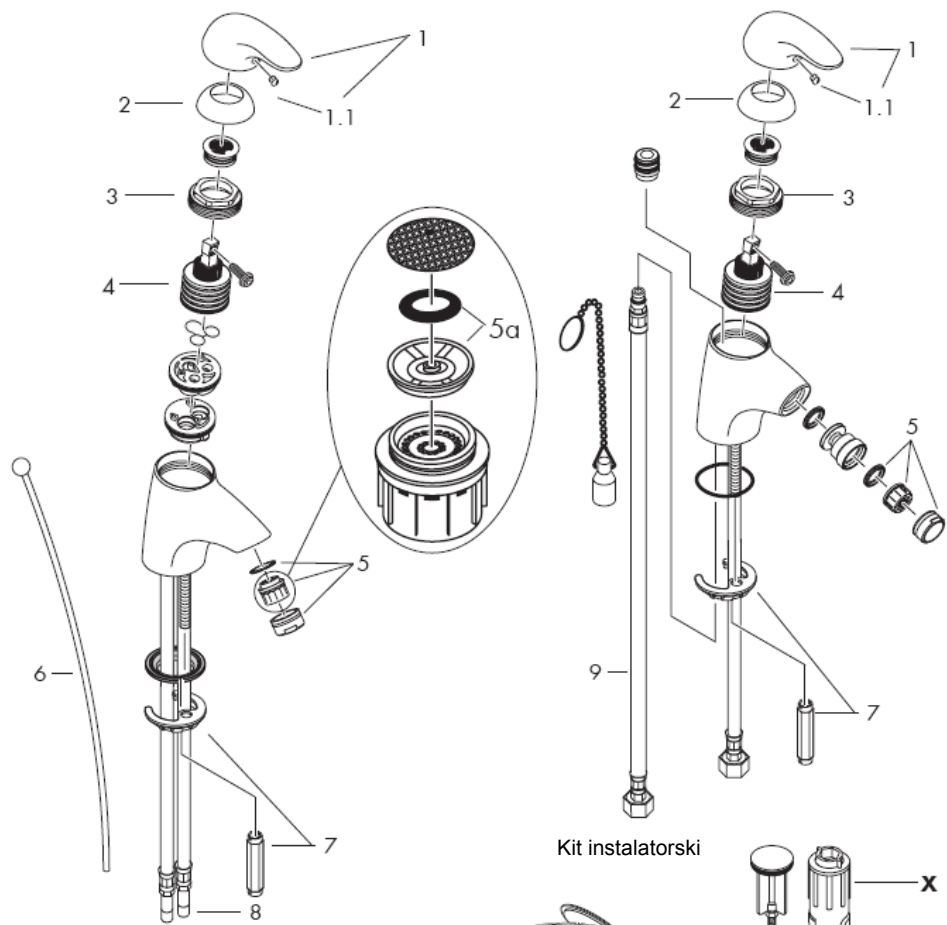

Kit instalatorski

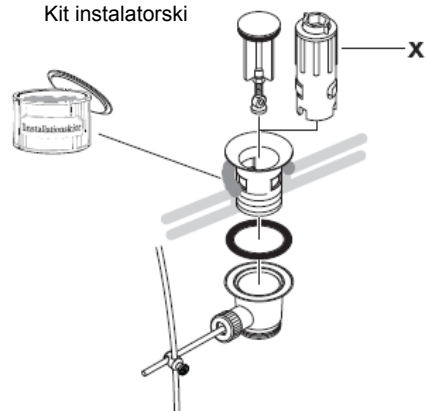

Uwaga! Armatura musi być zamontowana, przepłukana i wypróbowana według obowiązujących norm!

Montaż

- 1 Przepłukać instalację
- 2 Armaturę z podkładką izolującą umieścić w umywalce / bidetcie.
- 3 Nasunąć podkładkę i płytkę mocującą przez rurki przyłączeniowe i trzpień gwintowany i dokręcić nakrętką.
- 4 Podłączyć wężyki do zaworków kątowych, zimna prawo - ciepła lewo.
- 5 33001000/32002XXX/33200XXX/33202XXX: Podłączyć ściągno z zaworem odpływowym.

Znaczne różnice ciśnień na dopływach ciepłej i zimnej wody muszą zostać wyrównane.

Obsługa

Przez skierowanie uchwytu do góry następuje jego uruchomienie.

Obrót uchwytu w lewo = ciepła woda,

Obrót uchwytu w prawo = zimna woda.

Dane techniczne

Armatura produkowana seryjnie z funkcją Waterdimmer® (ogranicznik przepływu).

Wydajność przepływu z ogranicznikiem przepływu Waterdimmer:

7 l/min 0,3 MPa

Wydajność przepływu bez ogranicznika przepływu Waterdimmer:

12 l/min 0,3 MPa

Ciśnienie robocze: max. 1 MPa

Zalecane ciśnienie robocze: 0,1 – 0,5 MPa

Ciśnienie próbne: 1,6 MPa

(1 MPa = 10 bary = 147 PSI)

Zalecana temperatura wody gorącej: max 80° C

Zalecana temperatura wody gorącej: 60° C

Mieszacze jednouchwytowe Hansgrohe mogą być stosowane w połączeniu z przepływowymi podgrzewaczami wody, sterowanymi hydraulicznie i termicznie, gdy ciśnienie wody wynosi co najmniej 0,15 MPa.

W przypadku problemów z przepływowymi podgrzewaczami wody lub jeśli chce się uzyskać większy przepływ wody, można usunąć Waterdimmer® (ogranicznik przepływu 5a) znajdujący się za napowietrzaczem.

Mieszacz jednouchwytowy z ogranicznikiem temperatury wody, ustawianie, patrz str. 8. W połączeniu z przepływowym podgrzewaczem wody ogranicznik temperatury wody nie jest konieczny.

Części serwisowe patrz strona 5

1	Uchwyt	33091000
1.1	Zaślepka uchwyt	94191000
2	Rozeta kulowa	94192000
	Złota rozeta kulowa	94192990
3	Nakrętka	94194000
4	Wkład kpl.	92730000
5	Napowietrzacz kpl. (10)	13912000
	Napowietrzacz kpl. gold	94980990
	Napowietrzacz kpl. (6 l/min)	96788000
6	Ściągno	92620000
	Ściągno złoty szlachetna	92620990
7	Mocowanie	96016000
8	Wąż przyłączeniowy	95001000
9	Wąż przyłączeniowy	97206000

Wyposażenie specjalne

X zestaw kluczy montażowych 58085000 (nie jest częścią dostawy)

Polski

Znak jakości

	DVGW	P-IX	SVGW	ACS	NF	WRAS	KIWA
33001000	X	P-IX 8388/IA	X			X	X
33002XXX	X	P-IX 8388/IA	X		X		X
33006000	X	P-IX 8388/IA	X				X
33007000							
33008000	X	P-IX 8388/IA	X		X		X
33011000							
33200XXX	X	P-IX 8388/IA	X			X	X
33202XXX	X	P-IX 8388/IA	X		X		X
33208000	X	P-IX 8388/IA	X		X		X

Ogranicznik ciepłej wody: Temperatura ciepłej wody 60 C, temperatura zimnej wody 10 C, ciśnienie przepływu 0,3 MPa.

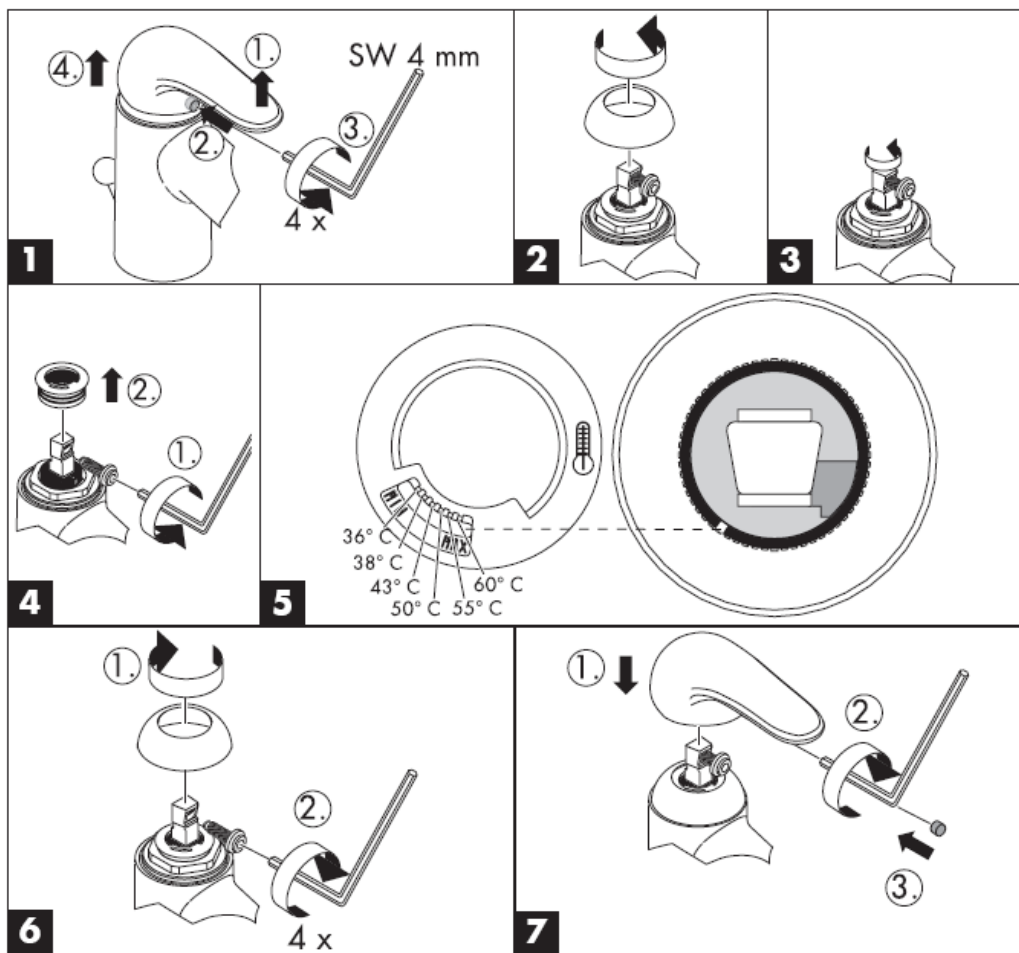

Czyszczenie

Funkcja Rubit® wymaga jedynie delikatnego potarcia dłonią, aby usunąć ewentualne osady kamienia wapiennego.



hansgrohe

Hansgrohe · Postfach 1145 · D-77761 Schiltach · Telefon +49 (0) 78 36/51-1282 · Telefax +49 (0) 7836/511440
E-Mail: info@hansgrohe.com · Internet: www.hansgrohe.com

05/2006
9.07956.04
Polski

Montážní návod



Talis E

33001000/33002XXX/33006000
33007000/33008000/33011000



Talis E

33200XXX/33202XXX/33208000

hansgrohe

33001000

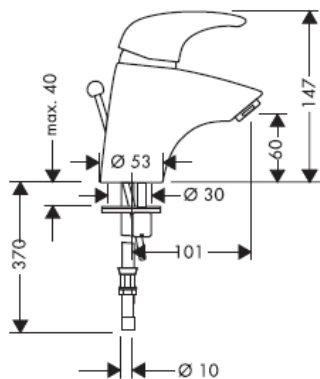

33200XXX

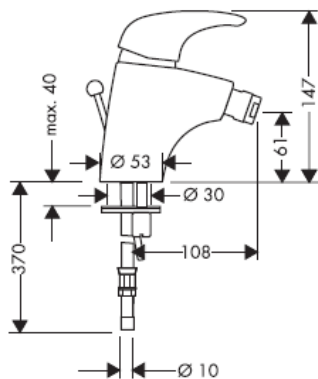

33002XXX

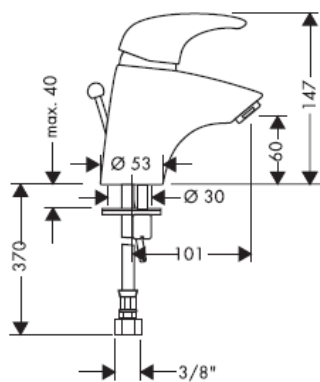

33202XXX

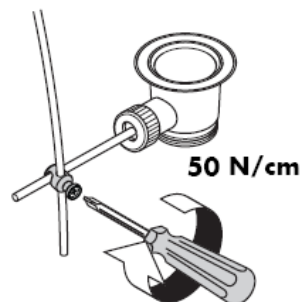
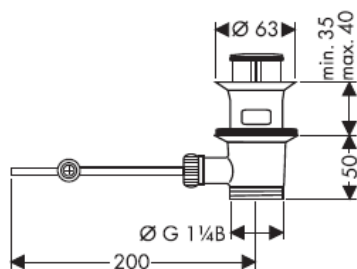
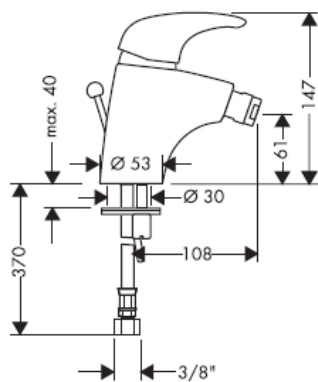

33008000

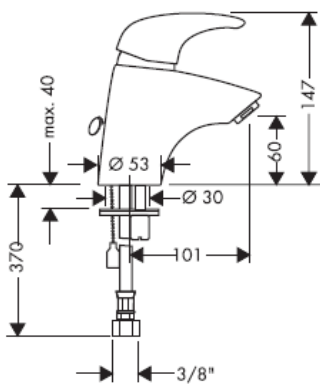

33208000

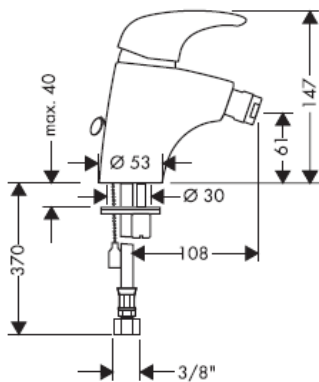

33006000

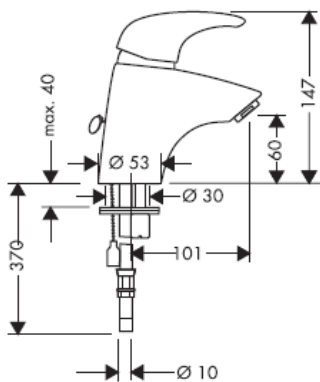

33007000

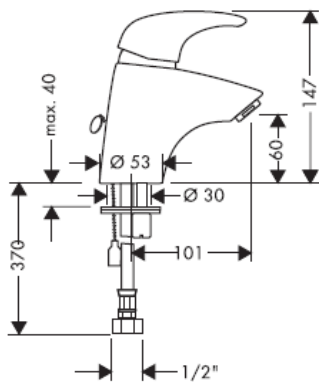

33011000

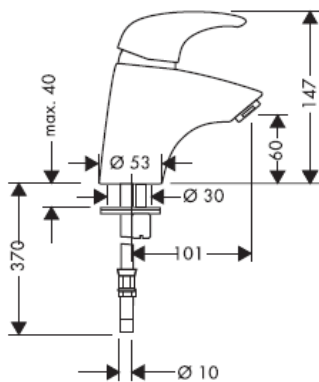

Montáž připojovací hadičky

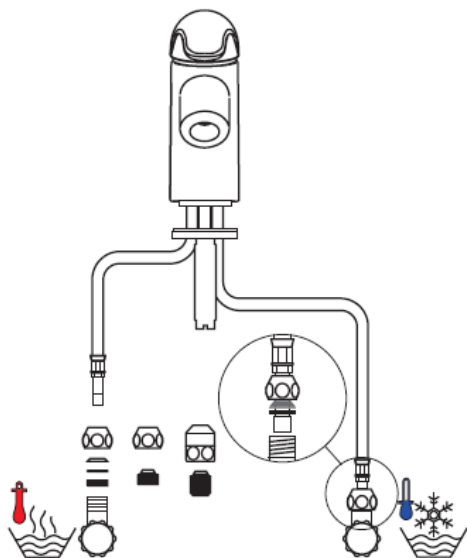
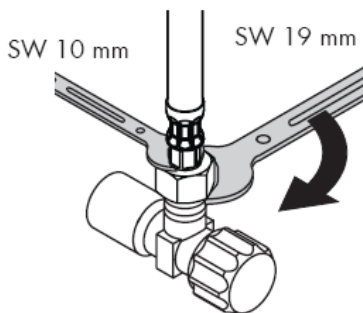
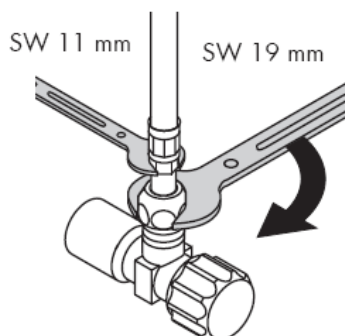
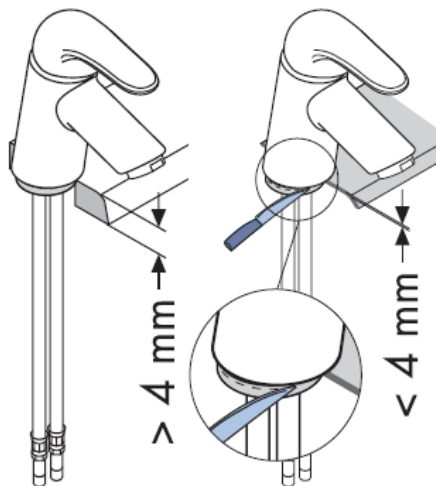
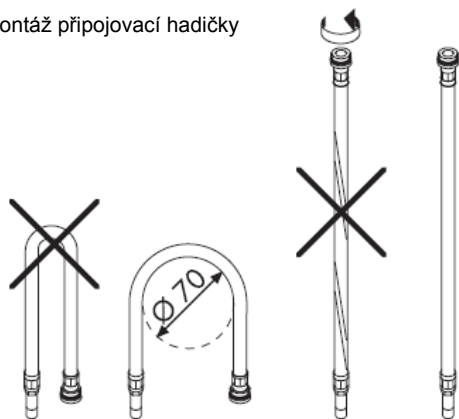

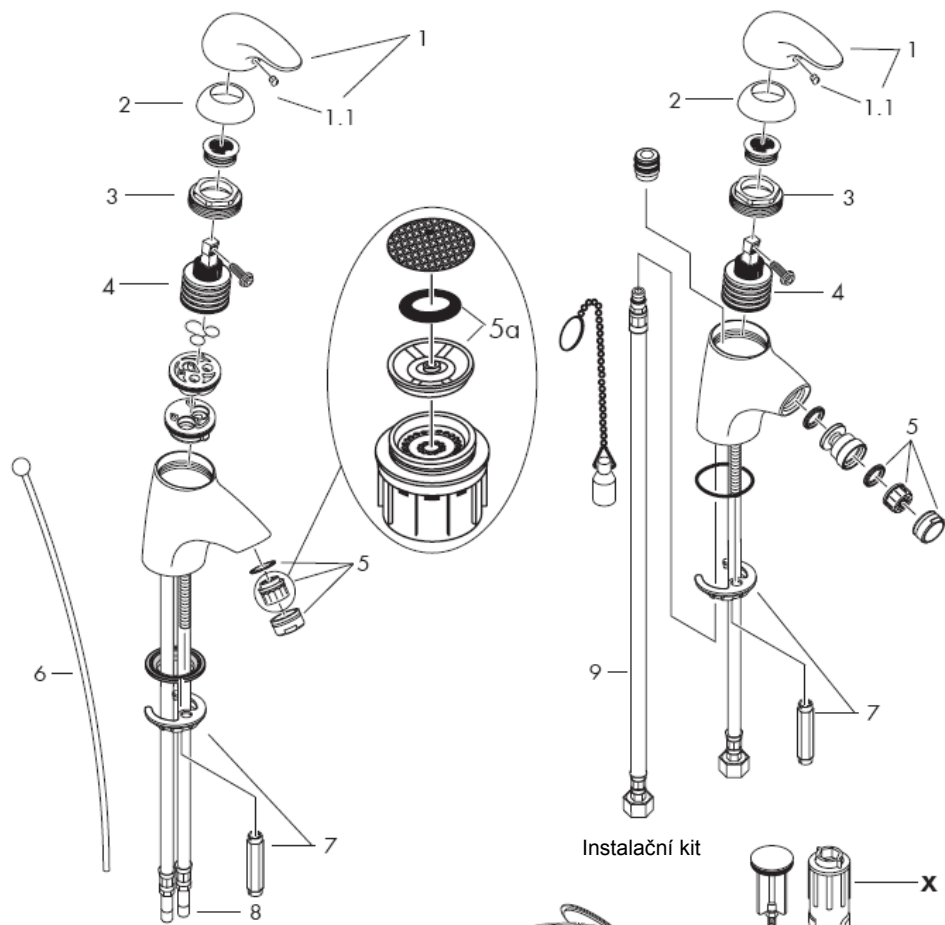

Instalační kit

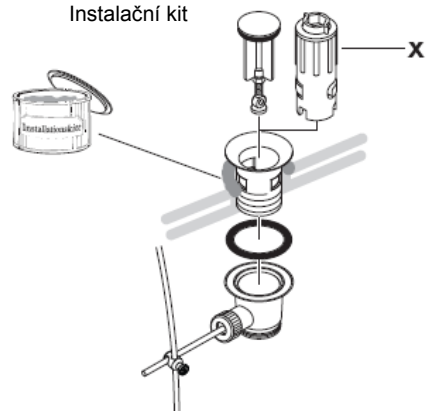

Pozor! Armatura se musí montovat, proplachovat a testovat podle platných norem!

Montáž

- 1 Přívodní trubky odborně propláchnout.
- 2 Armaturu s vložkou nasadit do umyvadla/bidetu.
- 3 Podložku a upevňovací podložku posunout přes přípojovací hadičky a stavěcí šrouby se zářezy a maticemi pevně utáhnout.
- 4 Přípojovací hadičky připojit na rohové ventily,
- 5 studená vpravo, teplá vlevo.
- 6 33001000/32002XXX/33200XXX/
33202XXX: Táhlo spojit s odtokovým ventilem.

Je nutné vyrovnat velké rozdíly tlaku mezi přípoji studené a teplé vody.

Ovládání

Baterie se otevírá zvednutím rukojeti.
Otočení doleva = teplá voda,
otočení doprava = studená voda.

Technické údaje

Armatura je sériově vybavena omezovačem průtoku (Waterdimmer®).

Průtok s omezovačem průtoku:

7 l/min 0,3 MPa

Průtok bez omezovače průtoku:

12 l/min 0,3 MPa

Provozní tlak: max. 1 MPa

Doporučený provozní tlak: 0,1 – 0,5 MPa

Zkušební tlak: 1,6 MPa

(1 MPa = 10 bar = 147 PSI)

Doporučená teplota horké vody: max 80° C

Doporučená teplota horké vody: 60° C

Pákové baterie Hansgrohe mohou být používány ve spojení s hydraulicky nebo tepelně řízenými průtokovými ohřivači, pokud tlak při průtoku je alespoň 0,15 MPa.

Při problémech s průtokovým ohřivačem, nebo když je požadován větší průtok, může být odstraněn omezovač průtoku (5a), který je umístěn za perlátorem.

Páková baterie s omezením horké vody, seřízení viz. str. 8.

Ve spojení s průtokovými ohřivači není uzavěr teplé vody nutný.

Servisní díly viz strana 5

1	rukojeť	33091000
1.1	krytka šroubu	94191000
2	krytka	94192000
	krytka zlato	94192990
3	matka	94194000
4	kartuše kompl.	92730000
5	perlátor (10)	13912000
	perlátor gold	94980990
	perlátor (6 l/min)	96788000
6	Táhlo	92620000
	Táhlo zlato ocel	92620990
7	Upevnění dříky	96016000
8	Přípojovací hadička	95001000
9	Přípojovací hadička	97206000

Zvláštní příslušenství

X Sada montážních klíčů 58085000
(není součástí dodávky)

Česky

zkušební značka

	DVGW	P-IX	SVGW	ACS	NF	WRAS	KIWA
33001000	X	P-IX 8388/IA	X			X	X
33002XXX	X	P-IX 8388/IA	X		X		X
33006000	X	P-IX 8388/IA	X				X
33007000							
33008000	X	P-IX 8388/IA	X		X		X
33011000							
33200XXX	X	P-IX 8388/IA	X			X	X
33202XXX	X	P-IX 8388/IA	X		X		X
33208000	X	P-IX 8388/IA	X		X		X

Omezení teplé vody: teplota vody (teplé) 60 C, teplota studené vody 10 C, tlak proudu 0,3 MPa.

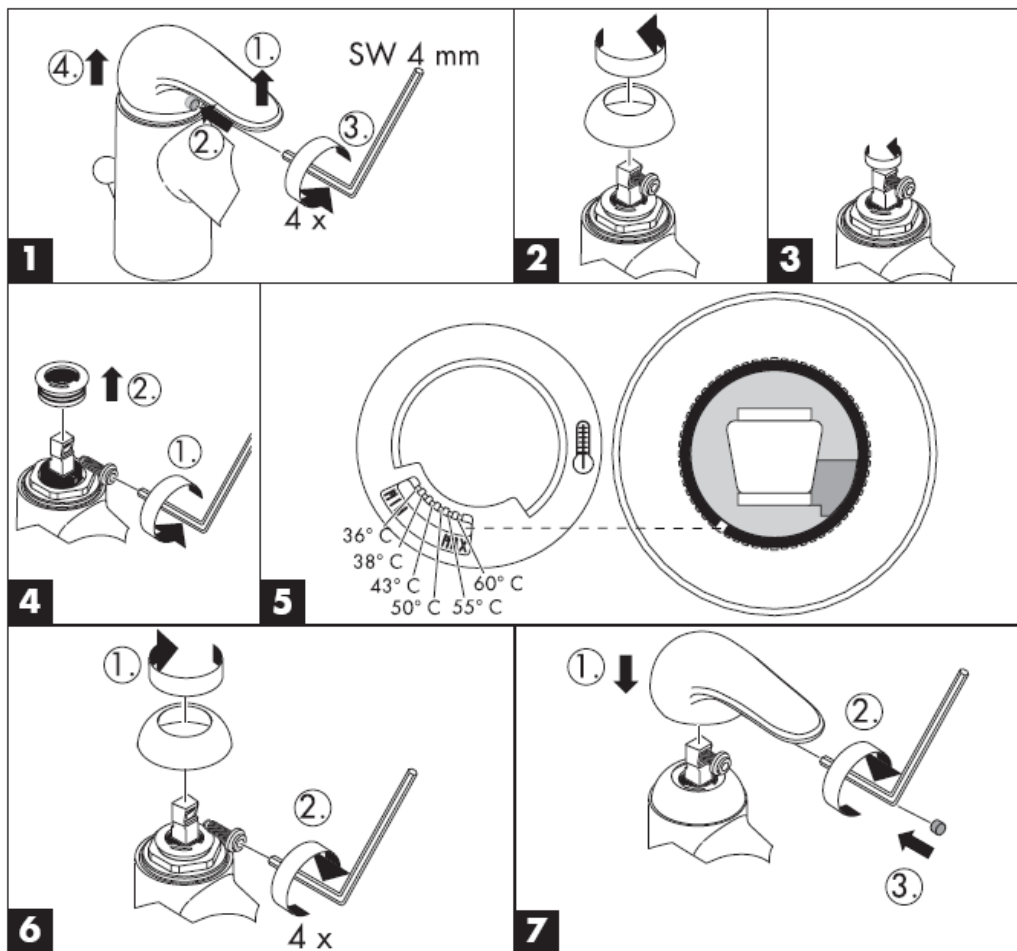

Čištění

S ruční čisticí funkcí Rubit® stačí jednoduché odstranění vodního kamene prsty z trysek kotouče tvarujícího proud vody.



hansgrohe

Hansgrohe · Postfach 1145 · D-77761 Schiltach · Telefon +49 (0) 78 36/51-1282 · Telefax +49 (0) 7836/511440
E-Mail: info@hansgrohe.com · Internet: www.hansgrohe.com

05/2006
9.07956.04
Česky

Montážny návod



Talis E

33001000/33002XXX/33006000
33007000/33008000/33011000



Talis E

33200XXX/33202XXX/33208000

hansgrohe

33001000

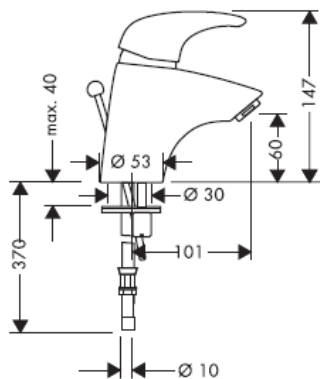

33200XXX

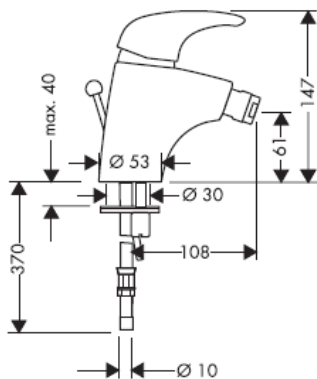

33002XXX

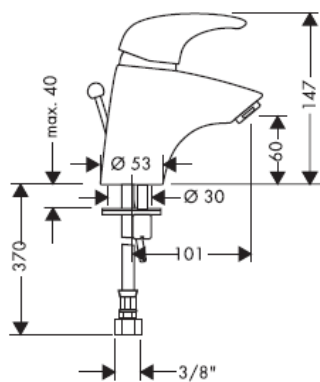

33202XXX

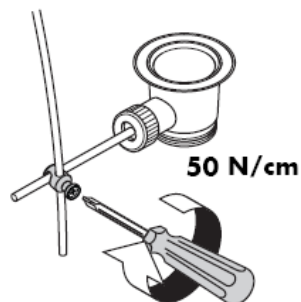
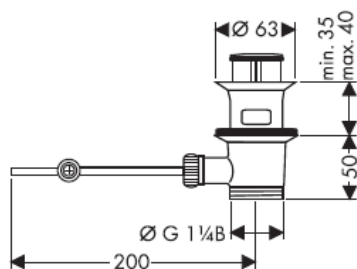
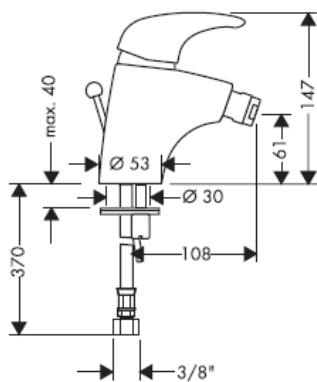

33008000

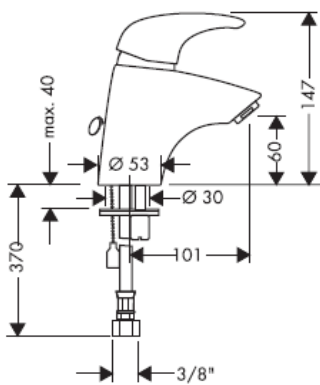

33208000

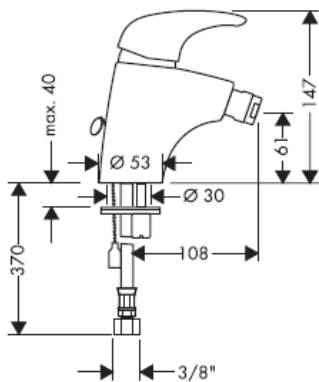

33006000

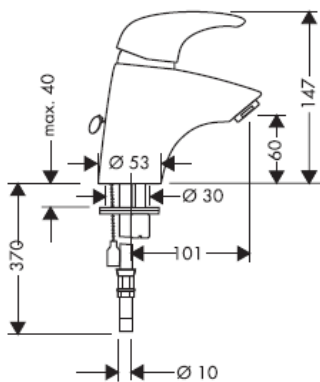

33007000

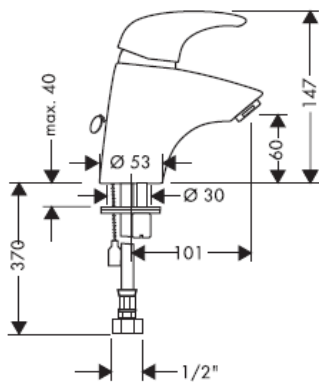

33011000

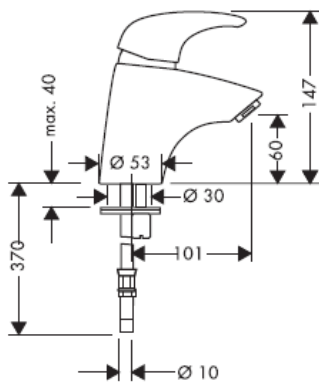

Montáž pripojovacej hadičky

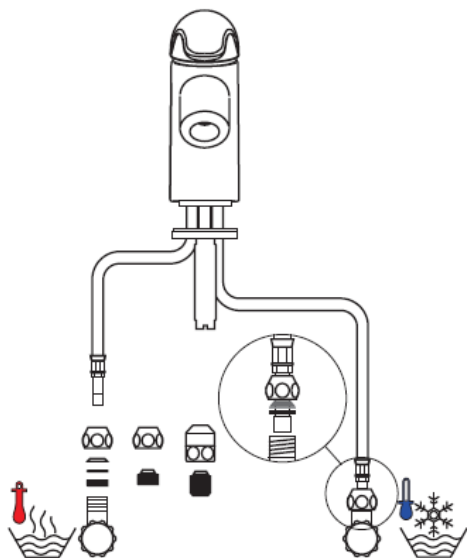
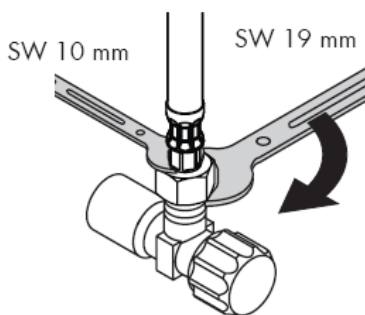
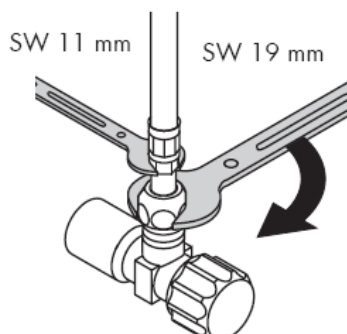
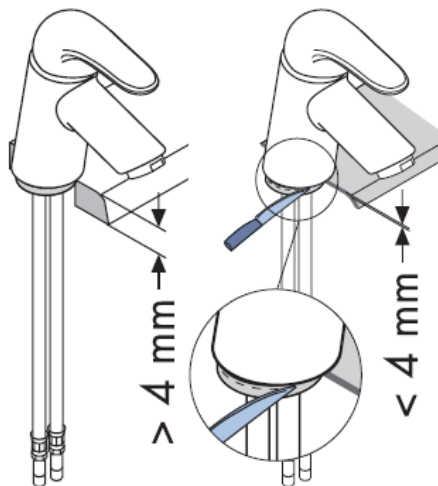
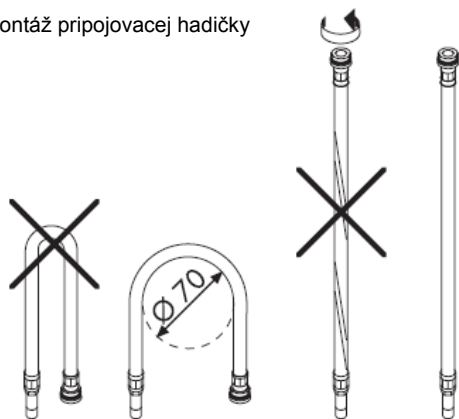

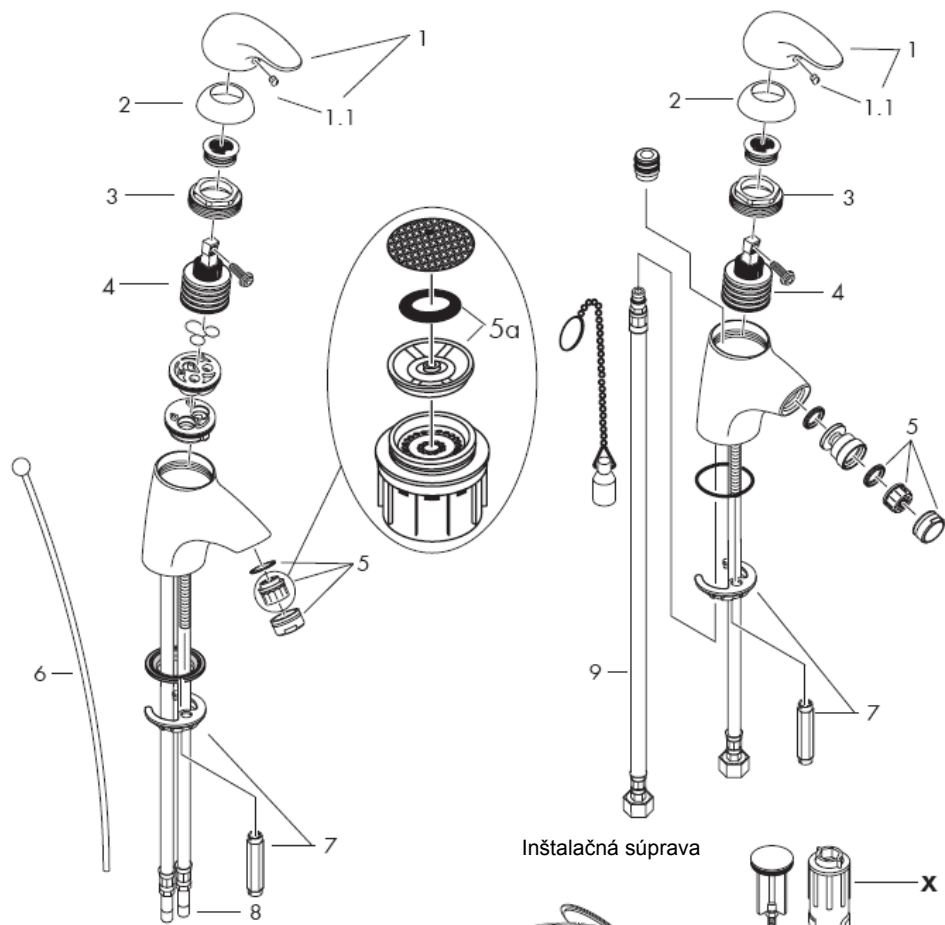

Inštalčná súprava

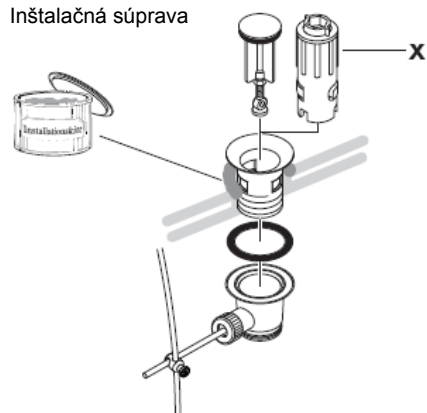

Pozor! Batéria sa musí montovať, preplachovať a testovať podľa platných noriem!

Montáž

- 1 Prívodné trubky odborne prepláchnuť.
- 2 Batériu umiestniť spolu s tesniacou podložkou na umývadlo alebo bidet.
- 3 Podložku a upevňovaciu podložku nasunúť cez pripojovacie hadičky a nastavovacie skrutky. Maticu dotiahnuť.
- 4 Pripojiť pripájacie hadičky na rohové ventily, studený vpravo - teplý vľavo
- 5 33001000/32002XXX/33200XXX/33202XXX: Ťažnú tyč spojiť s odtokovým entilom.

Veľké rozdiely v tlaku medzi prípojkami studenej a teplej vody musia byť vyrovnané.

Obsluha

Nadvihnutím páky sa zmiešavacia batéria otvorí. Otočenie páky vľavo = teplá voda. Otočenie páky vpravo = studená voda.

Technické údaje

Sériovo vyrábaná batéria s waterdimmer® (prietokový ventil).

Prietokové množstvo s prietokovým ventilom waterdimmer:

7 l/min 0,3 MPa

Prietokové množstvo bez prietokového ventilu waterdimmer:

12 l/min 0,3 MPa

Prevádzkový tlak: max. 1 MPa

Doporučený prevádzkový tlak: 0,1 – 0,5 MPa

Skúšobný tlak: 1,6 MPa

(1 MPa = 10 bar = 147 PSI)

Doporučená teplota teplej vody: max 80° C

Doporučená teplota teplej vody: 60° C

Pákové batérie firmy Hansgrohe môžu byť používané v spojení s hydraulicky a tepelne riadenými prietokovými ohrievačmi, pokiaľ je tlak prúdu aspoň 0,15 MPa.

Pri problémoch s prietokovým ohrievačom alebo ak je požadovaný väčší prietok vody, môže sa demontovať prietokový ventil (5a) waterdimmer®, ktorý je umiestnený za perlátorom.

Páková batéria s obmedzením teplej vody, nastavenie viď.str. 8.

V spojení s prietokovými ohrievačmi nie je uzáver teplej vody nutný.

Servisné diely viď strana 5

1	rukoväť	33091000
1.1	kryt skrutky	94191000
2	krytka	94192000
	krytka zlato	94192990
3	matica	94194000
4	kartuša kompl.	92730000
5	perlátor (10)	13912000
	perlátor gold	94980990
	perlátor (6 l/min)	96788000
6	ťažná tyč	92620000
	ťažná tyč zlato ocel	92620990
7	upevnenie pomocou kolíka	96016000
8	pripájacia hadička	95001000
9	pripájacia hadička	97206000

Zvláštne príslušenstvo

X Sada montážnych kľúčov 58085000 (nie je súčasťou dodávky)

Slovensky

Osvedčenie o skúške

	DVGW	P-IX	SVGW	ACS	NF	WRAS	KIWA
33001000	X	P-IX 8388/IA	X			X	X
33002XXX	X	P-IX 8388/IA	X		X		X
33006000	X	P-IX 8388/IA	X				X
33007000							
33008000	X	P-IX 8388/IA	X		X		X
33011000							
33200XXX	X	P-IX 8388/IA	X			X	X
33202XXX	X	P-IX 8388/IA	X		X		X
33208000	X	P-IX 8388/IA	X		X		X

Obmedzenie teplej vody: teplota teplej vody 60 C, teplota studené vody 10 C, tlak prúdu 0,3 MPa.

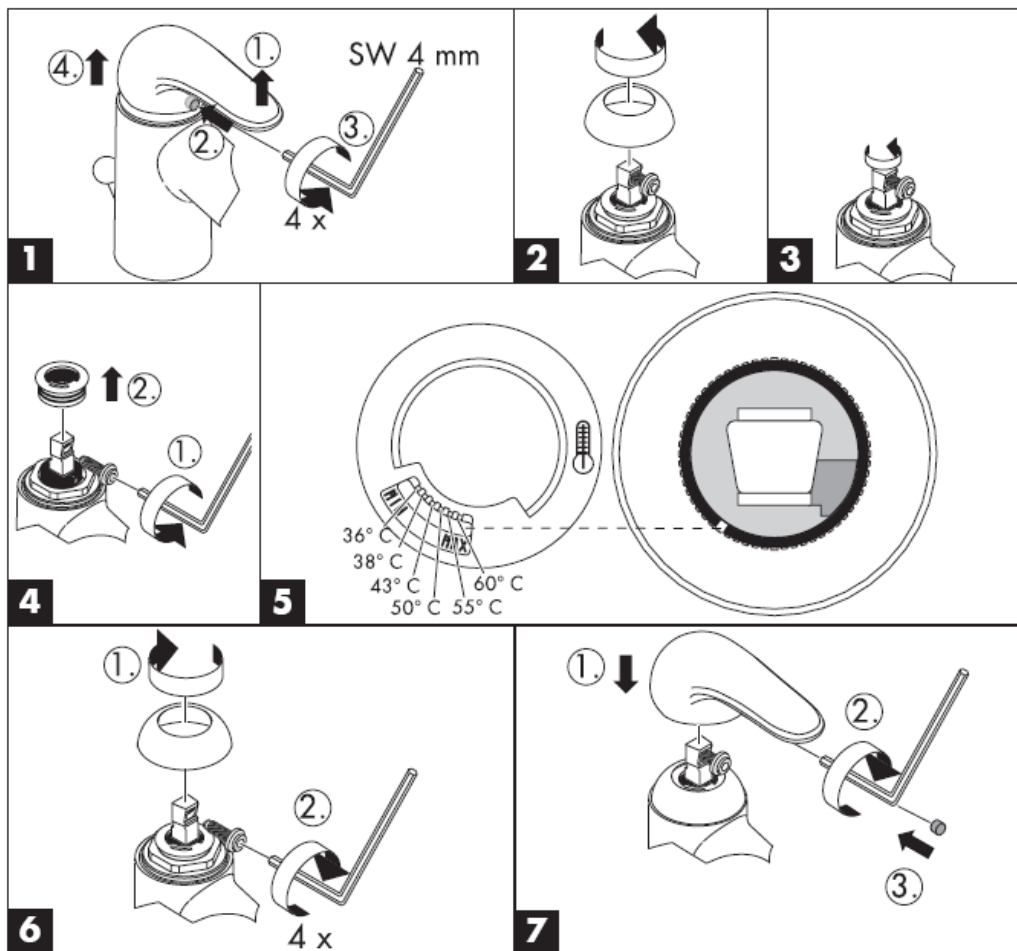

Čištění

Čistiaca funkcia Rubit, stačí na jednoduché odstránenie vodného kameňa prstami z trysiek kotúča tvarujúceho prúd vody.



hansgrohe

Hansgrohe · Postfach 1145 · D-77761 Schiltach · Telefon +49 (0) 78 36/51-1282 · Telefax +49 (0) 7836/511440
E-Mail: info@hansgrohe.com · Internet: www.hansgrohe.com

05/2006
9.07956.04
Slovensky

组装说明



Talis E

33001000/33002XXX/33006000
33007000/33008000/33011000



Talis E

33200XXX/33202XXX/33208000

hansgrohe

33001000

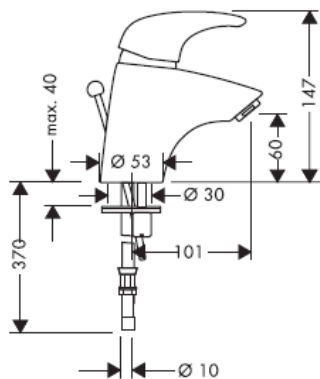

33200XXX

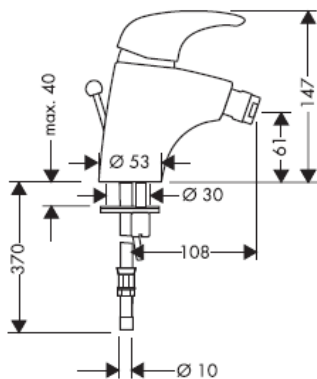

33002XXX

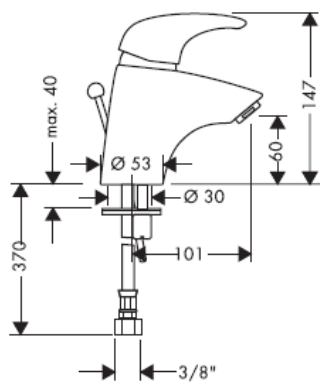

33202XXX

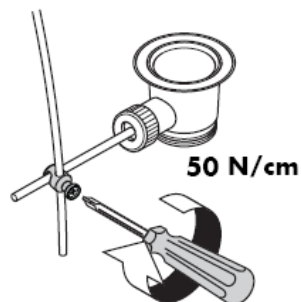
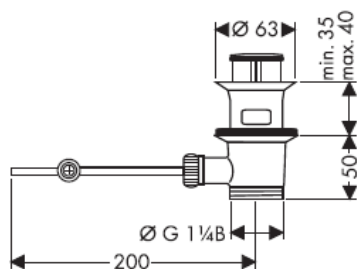
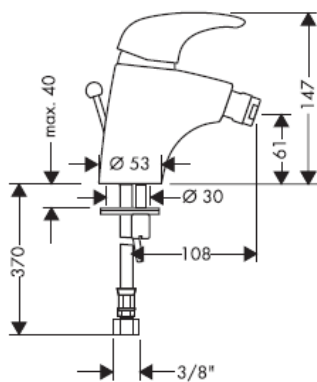

33008000

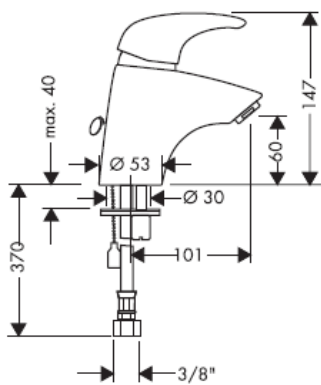

33208000

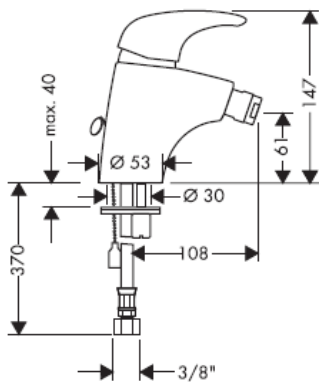

33006000

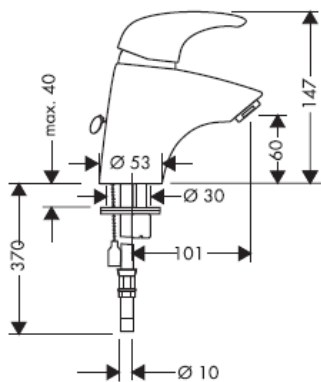

33007000

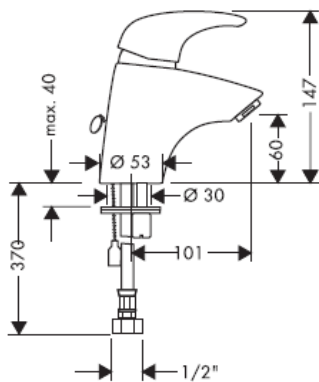

33011000

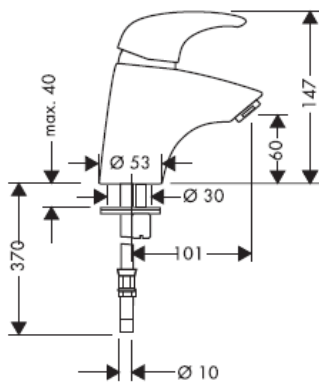

安装连接软管

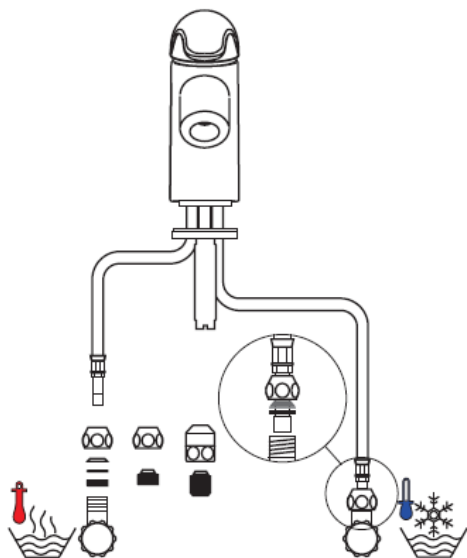
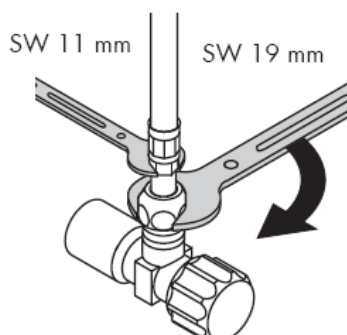
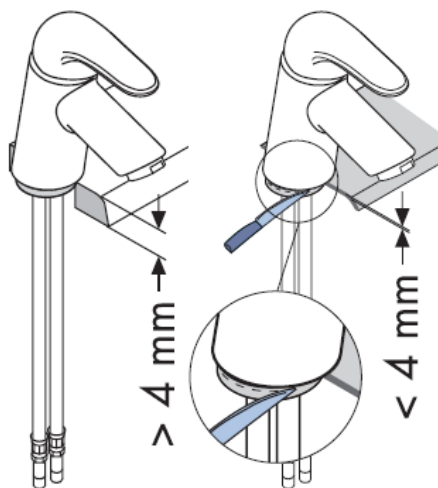
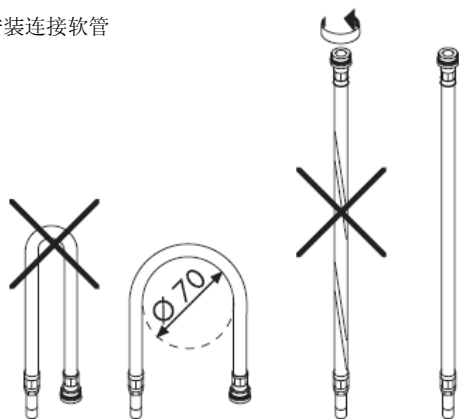

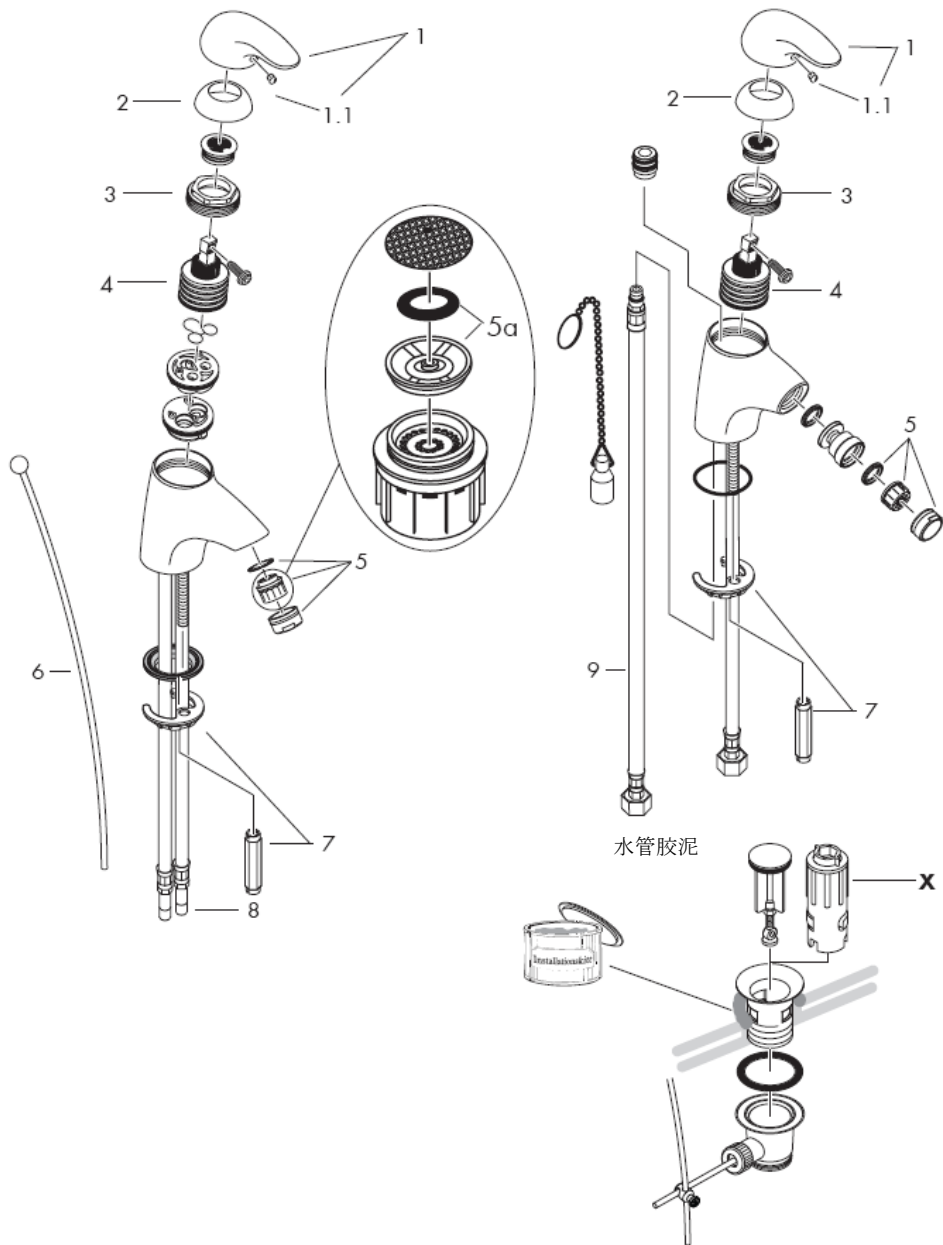

注意！

必须按照现行的规定安装，冲洗和测试产品！

安装

- 1 将进水管洗净。
- 2 将龙头和垫圈装在盥洗台/坐浴盆上。
- 3 将垫圈和固定片套到软管和螺销上，并用螺母固定。
- 4 连接三角阀和连接软管：左热右冷。
- 5 33001000/32002XXX/33200XXX/
33202XXX: 连接拉杆和排水阀。

冷热水管间过大的压力差必须予以平衡。

操作

提起手柄，龙头开启。

向左偏转：热水

向右偏转：冷水

技术参数

本产品配有Waterdimmer®（流量限制装置）

带有节流器时的流速：

7 l/min 0,3 MPa

不带节流器时的流速：

12 l/min 0,3 MPa

工作压强：

max. 1 MPa

推荐工作压强：

0,1 – 0,5 MPa

测试压强：

1,6 MPa

(1 MPa = 10 bar = 147 PSI)

推荐热水温度：

max 80° C

推荐热水温度：

60° C

如果水压达到1.5

bar以上，汉斯格雅单手柄龙头可以和液压式或热控制式直流式热水器一起使用。

如果使用直流式热水器有问题，或要求更大的水流量，可以把位于水波器后面的流量限制器（5a）拆除。

带有热水控制器的单手柄龙头的调节方法，参见第8页。

如果与连续流热水器一起使用，则不必作任何调节。

备用零件 参见第页 5

1	手柄	33091000
1.1	螺钉帽	94191000
2	法兰	94192000
	镀金法兰	94192990
3	螺母	94194000
4	阀体	92730000
5	水波器 (10)	13912000
	水波器 gold	94980990
	水波器 (6 l/min)	96788000
6	提拉杆	92620000
	提拉杆 金色	92620990
7	固定件	96016000
8	连接软管	95001000
9	连接软管	97206000

选装附件

X 安装工具 58085000
(不在供货范围内)

检验标记

	DVGW	P-IX 8388/IA	SVGW	ACS	NF	WRAS	KIWA
33001000	X	P-IX 8388/IA	X			X	X
33002XXX	X	P-IX 8388/IA	X		X		X
33006000	X	P-IX 8388/IA	X				X
33007000							
33008000	X	P-IX 8388/IA	X		X		X
33011000							
33200XXX	X	P-IX 8388/IA	X			X	X
33202XXX	X	P-IX 8388/IA	X		X		X
33208000	X	P-IX 8388/IA	X		X		X

热水限制：热水温度60 C，冷水温度10 C，流动压力3 bar

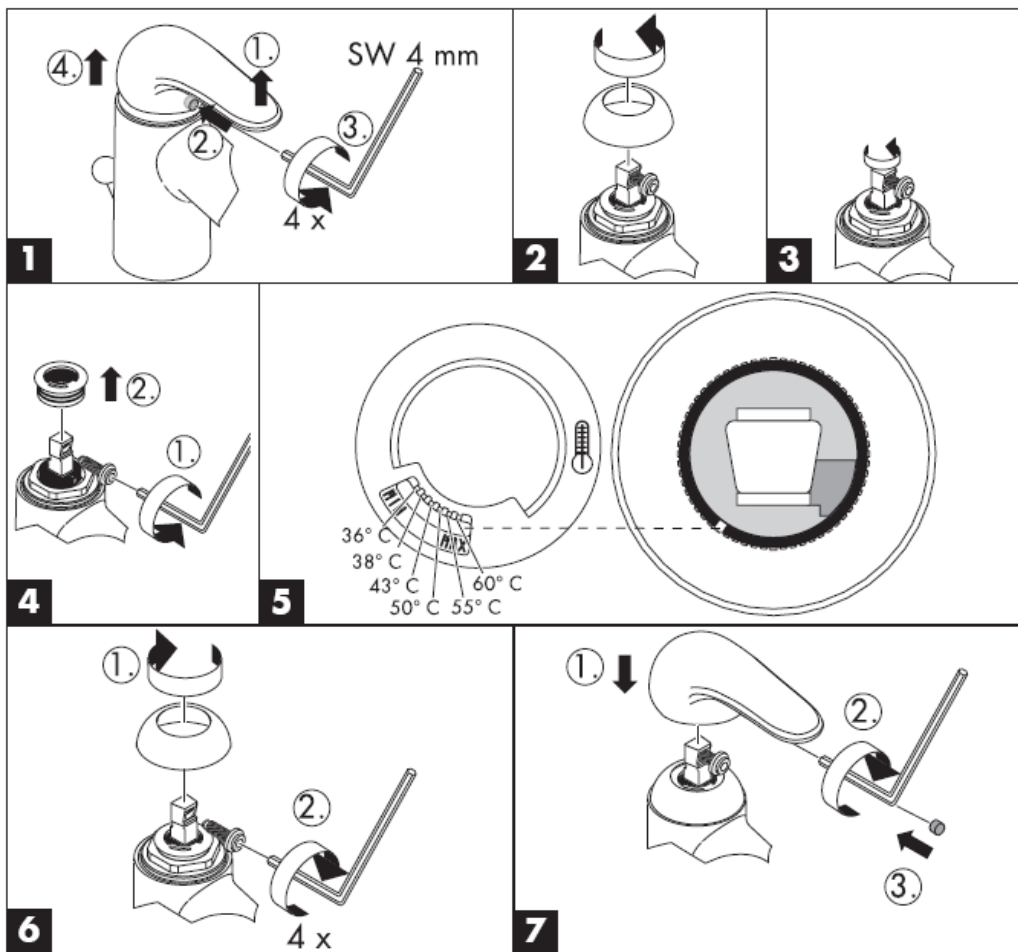

清洗

有了Rubit®, 手工清洁功能, 要去掉喷头上的水垢, 只需简单地搓除即可。



hansgrohe

Hansgrohe · Postfach 1145 · D-77761 Schiltach · Telefon +49 (0) 78 36/51-1282 · Telefax +49 (0) 7836/511440
E-Mail: info@hansgrohe.com · Internet: www.hansgrohe.com

05/2006
9.07956.04
中文

Инструкция по монтажу



Talis E

33001000/33002XXX/33006000
33007000/33008000/33011000



Talis E

33200XXX/33202XXX/33208000

hansgrohe

33001000

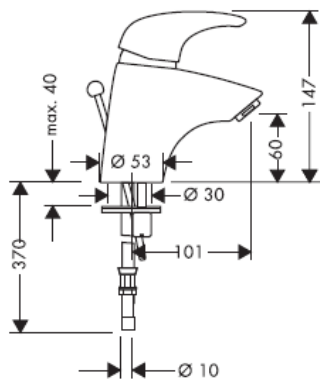

33200XXX

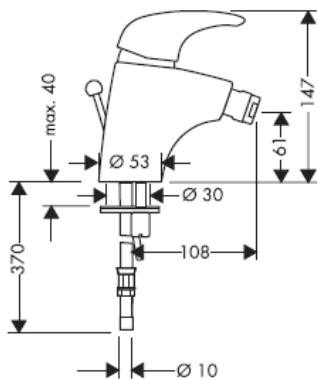

33002XXX

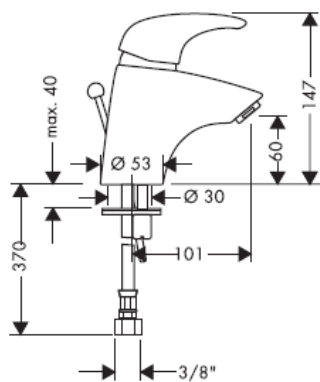

33202XXX

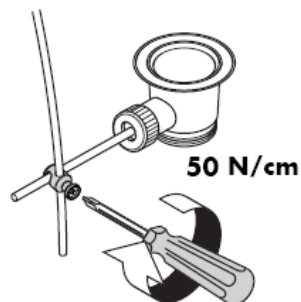
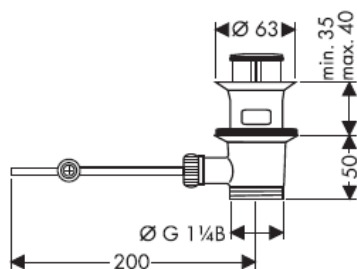
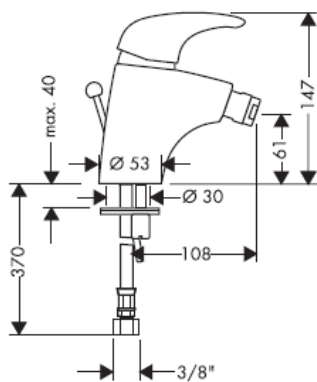

33008000

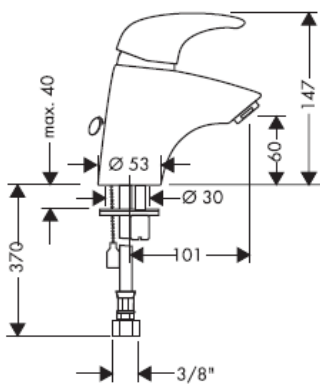

33208000

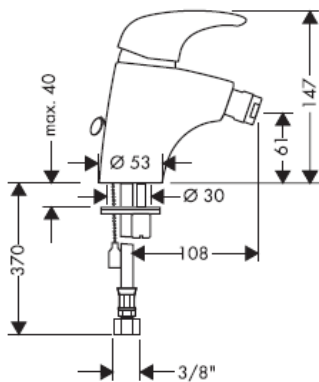

33006000

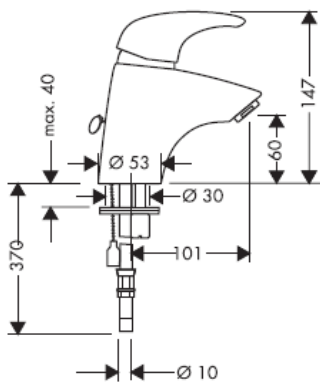

33007000

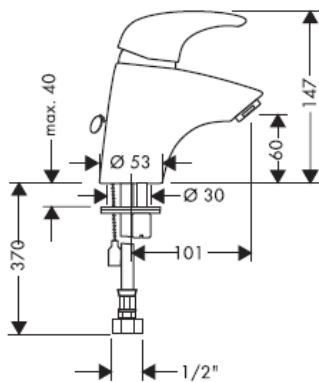

33011000

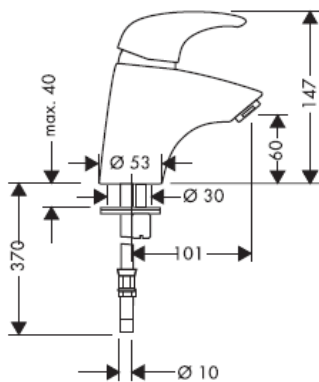

Монтаж подводки

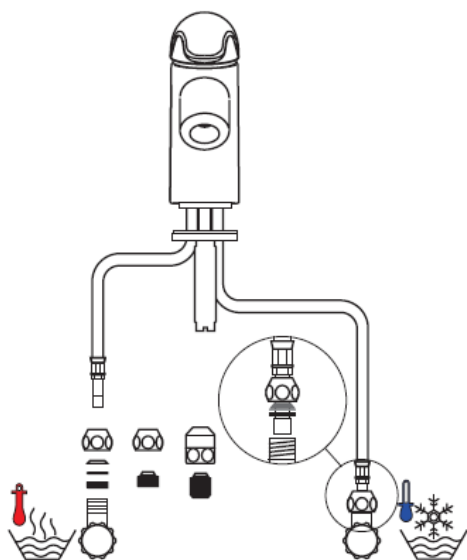
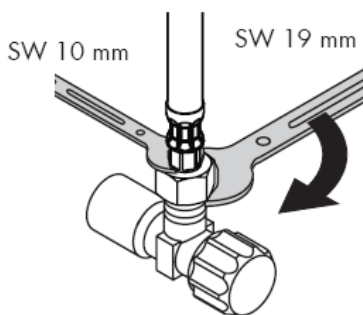
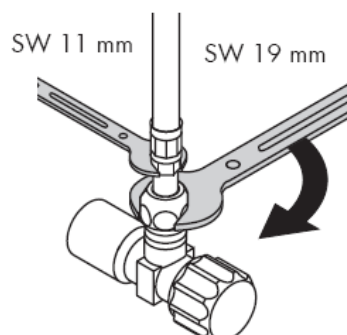
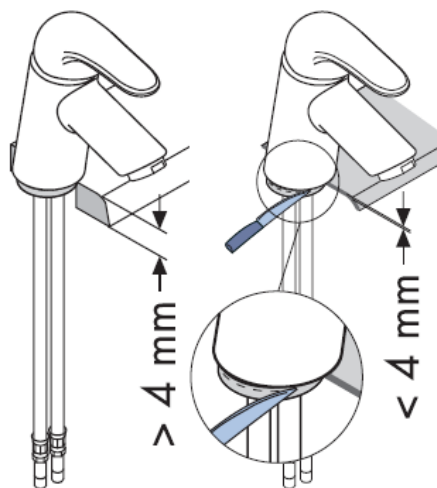

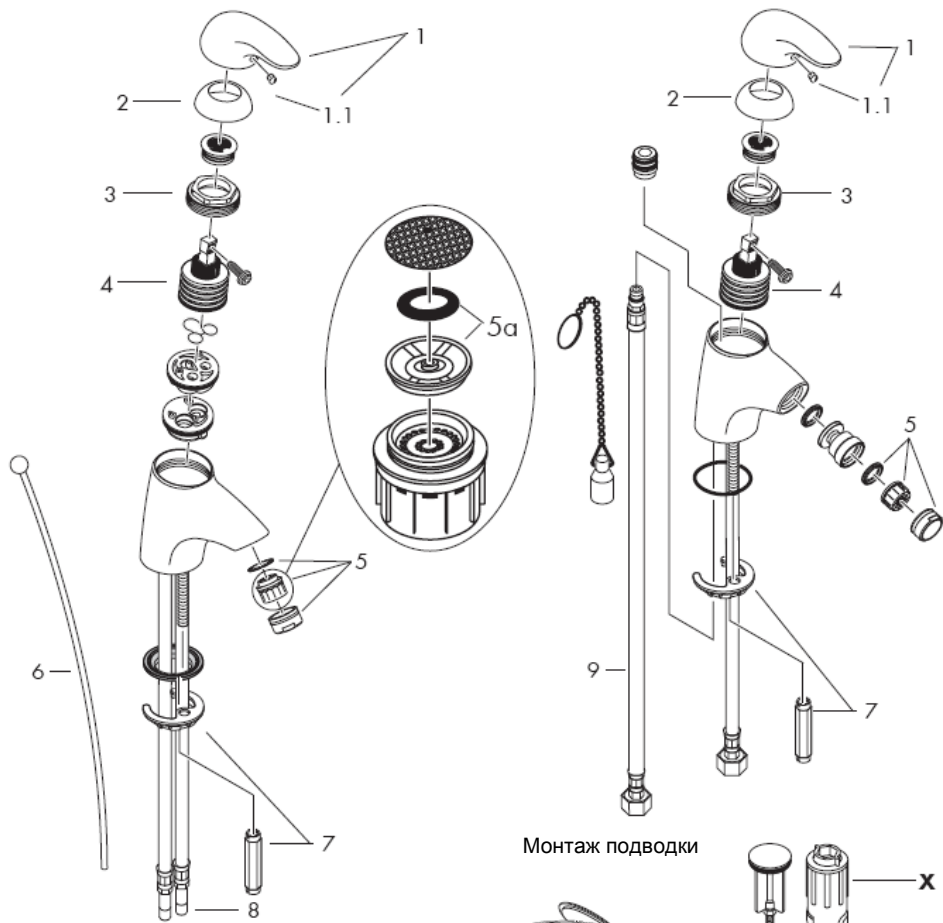

Монтаж подводки

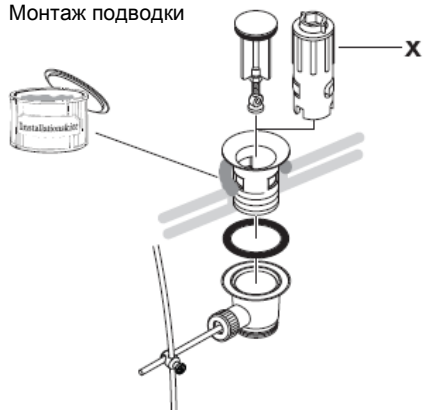

Осторожно! Смеситель должен быть смонтирован по действующим нормам и в соответствии с настоящей инструкцией, проверен на герметичность и безупречность работы

MPa
 Давление: 1,6 MPa
 (1 MPa = 10 bar = 147 PSI)
 Рекомендуемая темп. гор. воды: max 80° C
 Рекомендуемая темп. гор. воды: 60° C

Монтаж

- 1 тщательно промыть водопроводные трубы, спустив некоторое количество воды;
- 2 Арматуру с прокладкой вставьте в раковину / биде.
- 3 надеть прокладку и крепежный диск снизу на соединительные шланги, завернуть гайки рукой и затянуть винты отверткой;
- 4 присоединить шланги к угловым клапанам с цанговыми зажимами: холодный = справа, горячий = слева (шланг для горячей воды помечен красным цветом);
- 5 33001000/32002XXX/33200XXX/
33202XXX: присоединить тяги открытия и закрытия;

донного клапа. Перед установкой смесителя необходимо регулировочными кранами выровнять давление холодной и горячей воды при помощи вентилей регулирующих подачу воды в квартиру.

Эксплуатация

смеситель открывается поднятием рычага. Поворот рычага налево открывает горячую воду; поворот рычага направо открывает холодную воду.

Технические данные

Смесители этой серии оснащены ограничителем потока воды (Waterdimmer®)

Пропускная способность:

7 l/min 0,3 MPa

Пропускная способность без ограничителя потока воды (Waterdimmer):

12 l/min 0,3 MPa

Рабочее давление:

max. 1 MPa

Однорычажные смесители фирмы HANSGROHE можно использовать с электроводонагревателями бойлерного типа при минимальном давлении 0,15 МПа.

Если появятся проблемы с бойлером или потребуется увеличить расход воды (5а), который находится в подводке смесителя.

Однорычажный смеситель имеет ограничитель расхода горячей воды (см. Стр. 8: юстировка).

Комплект см. стр. 5

1	Рукоятка	33091000
1.1	Пробка декоративная	94191000
2	сферический колпачок	94192000
	золотистый колпачок	94192990
3	Гайка	94194000
4	картридж	92730000
5	аэратор (10)	13912000
	аэратор gold	94980990
	аэратор (6 l/min)	96788000
6	тяга	92620000
	тяга глянцевое золото	92620990
7	крепеж	96016000
8	Подводка	95001000
9	Подводка	97206000

Специальные принадлежности

специальный ключ для сборки\разборки смесителя, в комплект поставки не входит

Знак технического контроля

	DVGW	P-IX	SVGW	ACS	NF	WRAS	KIWA
33001000	X	P-IX 8388/IA	X			X	X
33002XXX	X	P-IX 8388/IA	X		X		X
33006000	X	P-IX 8388/IA	X				X
33007000							
33008000	X	P-IX 8388/IA	X		X		X
33011000							
33200XXX	X	P-IX 8388/IA	X			X	X
33202XXX	X	P-IX 8388/IA	X		X		X
33208000	X	P-IX 8388/IA	X		X		X

Ограничение расхода горячей воды: температура горячей воды 60 С, температура холодной воды 10 С, давление 0,3 МПа.

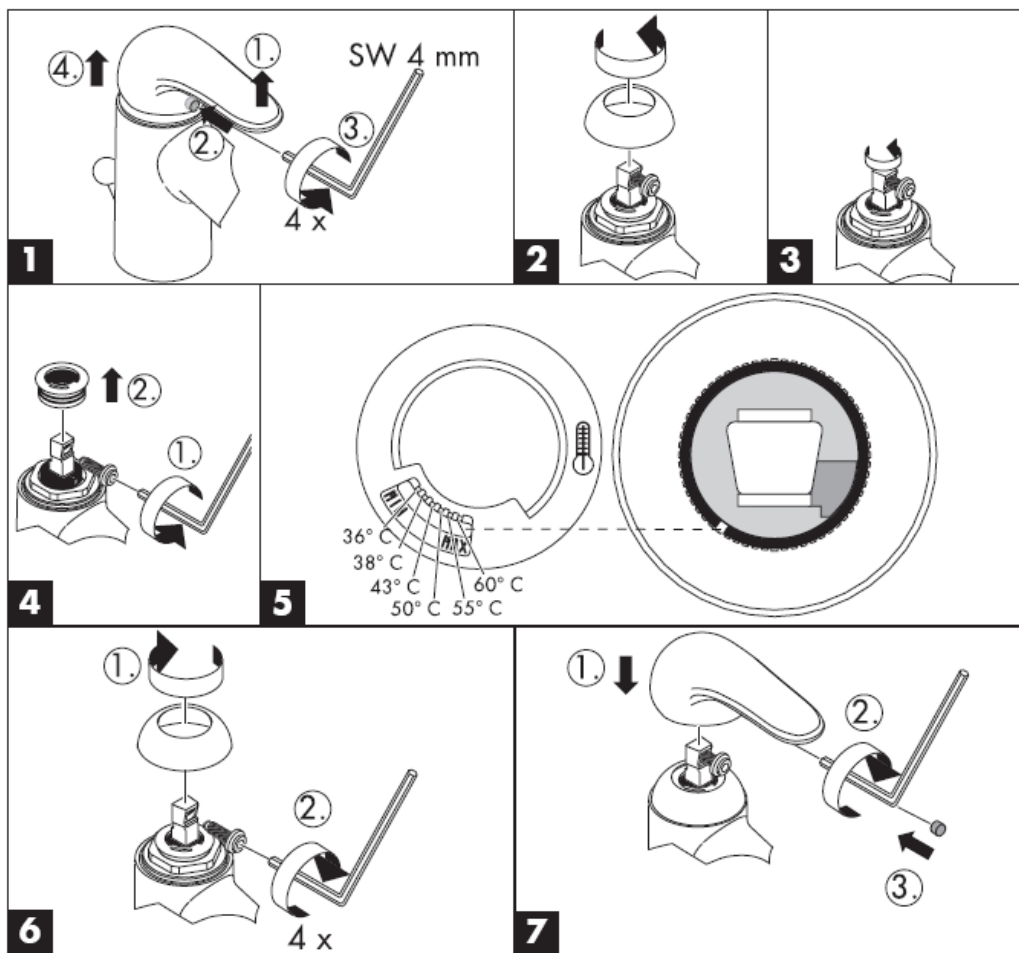

Очистка

система Rubit® позволяет удалять известковые отложения, достаточно провести по эластичной поверхности аэратора пальцем, как известковые отложения будут удалены.



hansgrohe

Hansgrohe · Postfach 1145 · D-77761 Schiltach · Telefon +49 (0) 78 36/51-1282 · Telefax +49 (0) 7836/511440
E-Mail: info@hansgrohe.com · Internet: www.hansgrohe.com

05/2006
9.07956.04
Русский

Szerelési útmutató



Talis E

33001000/33002XXX/33006000
33007000/33008000/33011000



Talis E

33200XXX/33202XXX/32208000

hansgrohe

33001000

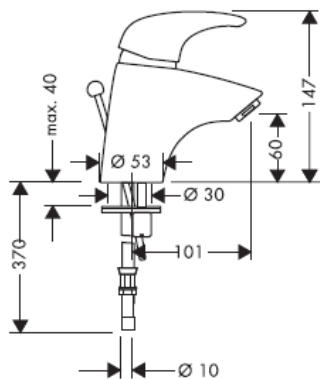

33200XXX

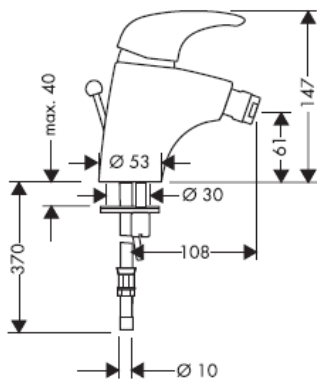

33002XXX

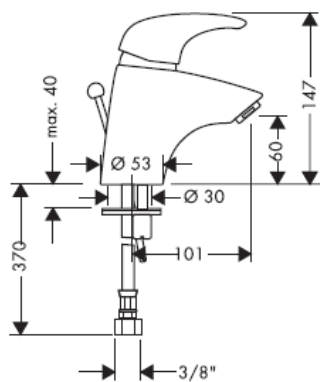

33202XXX

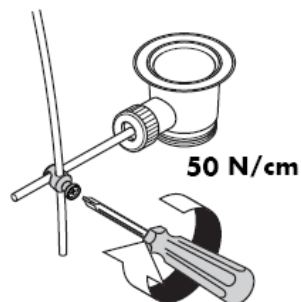
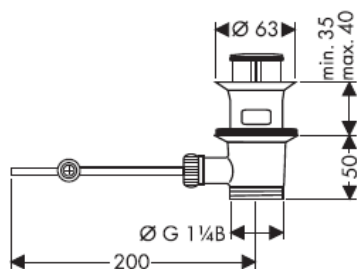
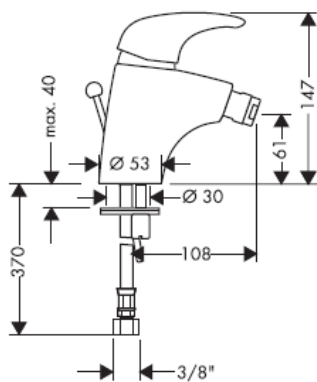

33008000

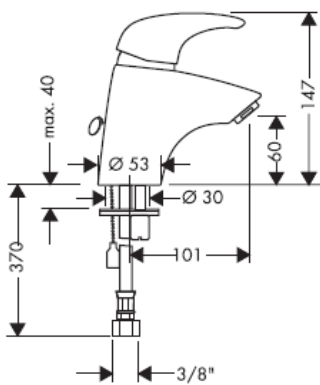

33208000

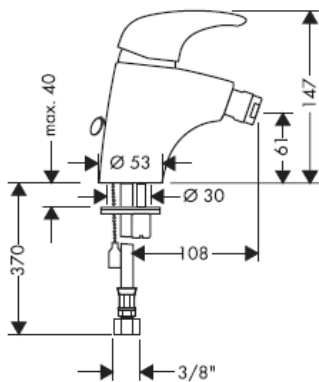

33006000

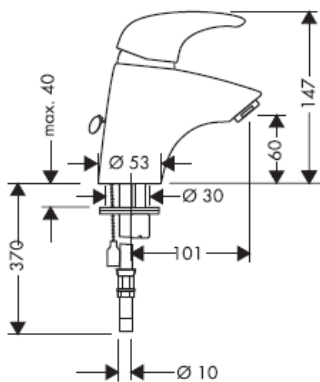

33007000

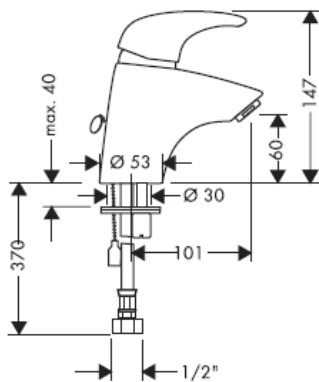

33011000

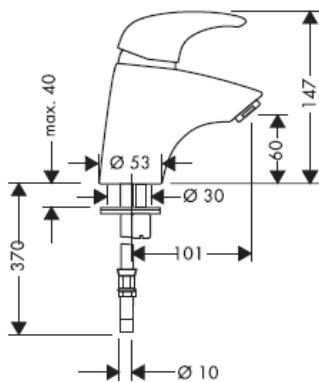

bekötőcső összeszerelése

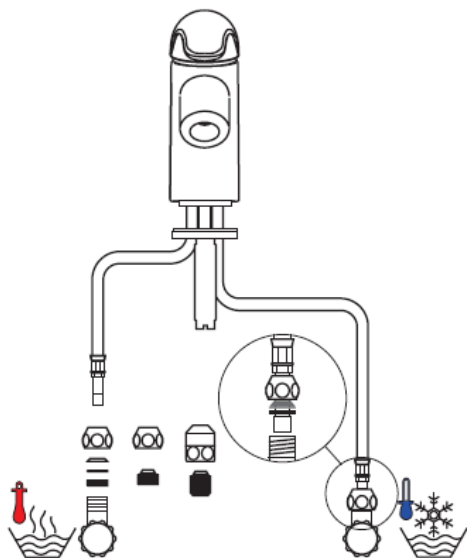
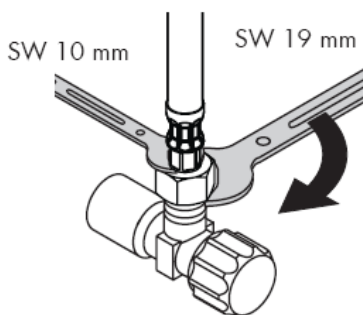
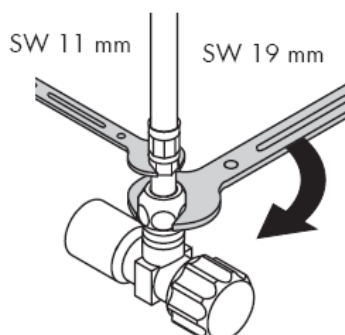
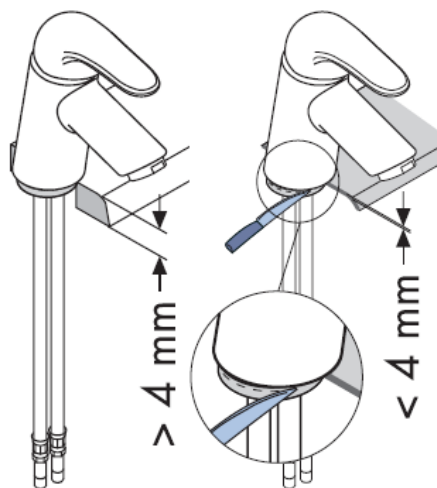
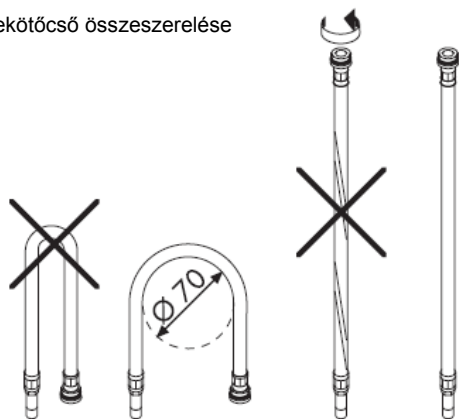

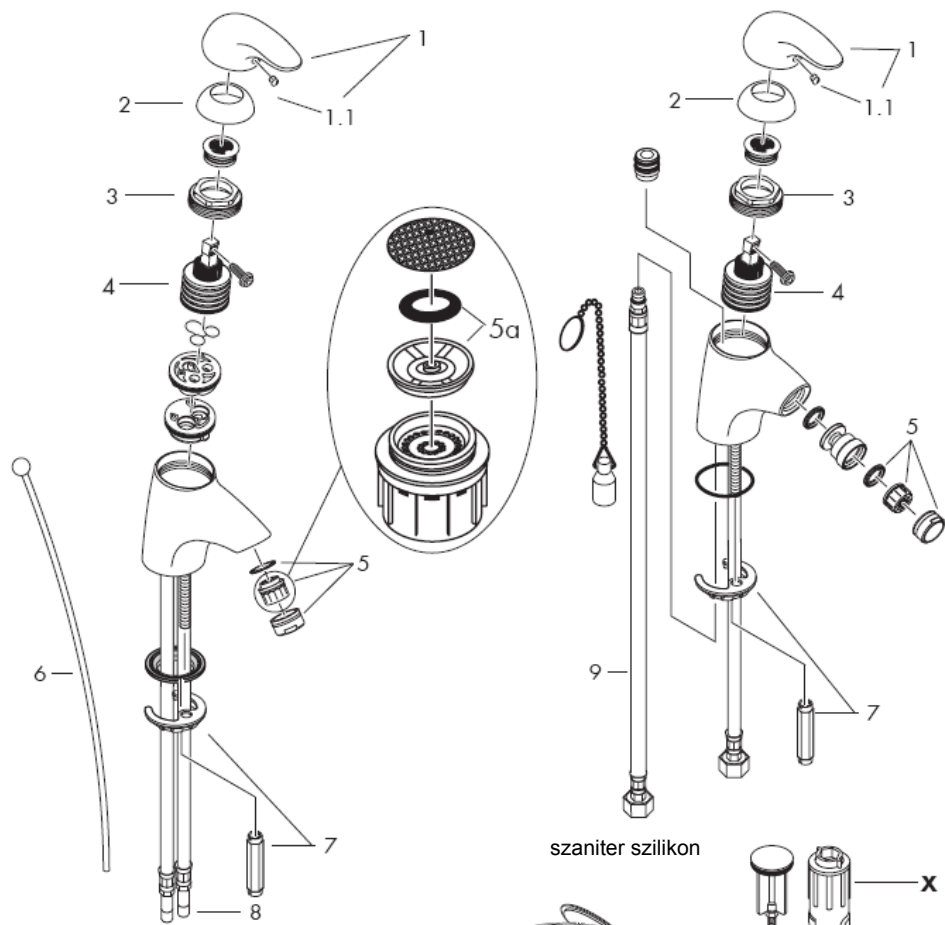

szaniter szilikon

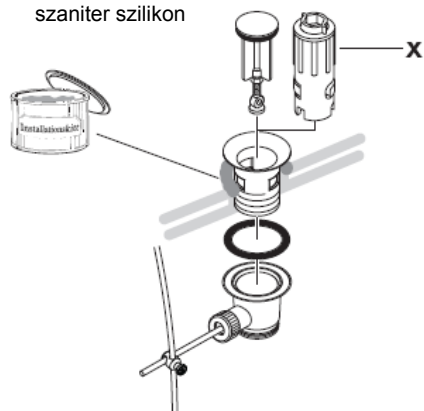

Figyelem! A csaptelepet az érvényben lévő előírásoknak megfelelően kell felszerelni, átöblíteni és ellenőrizni!

Szerelés

- 1 A vezetékeket gondosan átöblítjük.
- 2 A csaptelepet az alátétekkel a mosdóba ill. bidébe beállítjuk.
- 3 Az alsó alátétet és a rögzítő alátétet a bekötőcsövekre és a menetesrúdra felhúzzuk, majd az anyával rögzítjük.
- 4 A bekötőcsöveket rácsatlakoztatjuk a sarokszelepekre (hideg jobbra, meleg balra)
- 5 33001000/32002XXX/33200XXX/
33202XXX: A leeresztő rudat kössük össze a leeresztő szeleppel.

A hidegvíz- és a melegvíz-csatlakozások közötti nagy nyomáskülönbséget kikell egyenlíteni!

Használat

A keverőcsapot a fogantyú emelésével nyitjuk ki. Balra csavarva meleg víz, jobbra csavarva hideg víz folyik.

Műszaki adatok

A csaptelep szériakivitelben el van látva Waterdimmer® (átfolyás-határoló) berendezéssel.

átfolyó vízmennyiség vízkorlátozóval:

7 l/min 0,3 MPa

Átfolyási teljesítmény, Waterdimmer nélkül:

12 l/min 0,3 MPa

Üzemi nyomás: max. 1 MPa

Ajánlott üzemi nyomás: 0,1 – 0,5 MPa

Nyomáspróba: 1,6 MPa

(1 MPa = 10 bar = 147 PSI)

Forróvíz javasolt hőmérséklete: max 80° C

Forróvíz javasolt hőmérséklete: 60° C

A Hansgrohe egykaros keverő csaptelepek beépíthetők hidraulikus- és hőszabályozással ellátott átfolyós vízmelegítőknél egyaránt, ha a víznyomás legalább 0,15 MPa.

Ha problémák adódnak az átfolyós vízmelegítővel vagy nagyobb átfolyó vízmennyiségre van szükség, eltávolítható a Waterdimmer® (átfolyás- korlátozó 5a) a perlátor mögül.

Az egykaros, melegvíz-korlátozóval ellátott keverő csaptelep beállítását lásd a 8. oldalon. Az átfolyó rendszerű vízmelegítőknél nem szükséges a melegvíz-korlátozó.

Tartozékok lásd a oldalon 5

1	Fogantyú	33091000
1.1	Takaródugó a csavarhoz	94191000
2	Golyórozetta	94192000
	Arany sapka	94192990
3	Anyá	94194000
4	Betét	92730000
5	Perlátor (10)	13912000
	Perlátor gold	94980990
	Perlátor (6 l/min)	96788000
6	leeresztő rúd	92620000
	leeresztő rúd arany-hatású	92620990
7	Alsó rögzítőrész	96016000
8	Bekötőcső	95001000
9	Bekötőcső	97206000

Egyéb tartozék

X szerelőkulcs-készlet 58085000
(nem része az alapsomagnak)

Magyar

Vizsgajel

	DVGW	P-IX	SVGW	ACS	NF	WRAS	KIWA
33001000	X	P-IX 8388/IA	X			X	X
33002XXX	X	P-IX 8388/IA	X		X		X
33006000	X	P-IX 8388/IA	X				X
33007000							
33008000	X	P-IX 8388/IA	X		X		X
33011000							
33200XXX	X	P-IX 8388/IA	X			X	X
33202XXX	X	P-IX 8388/IA	X		X		X
33208000	X	P-IX 8388/IA	X		X		X

Melegvíz-korlátozás: melegvíz-hőmérséklet 60 C, hidegvíz-hőmérséklet 10 C, víznyomás 0,3 MPa.

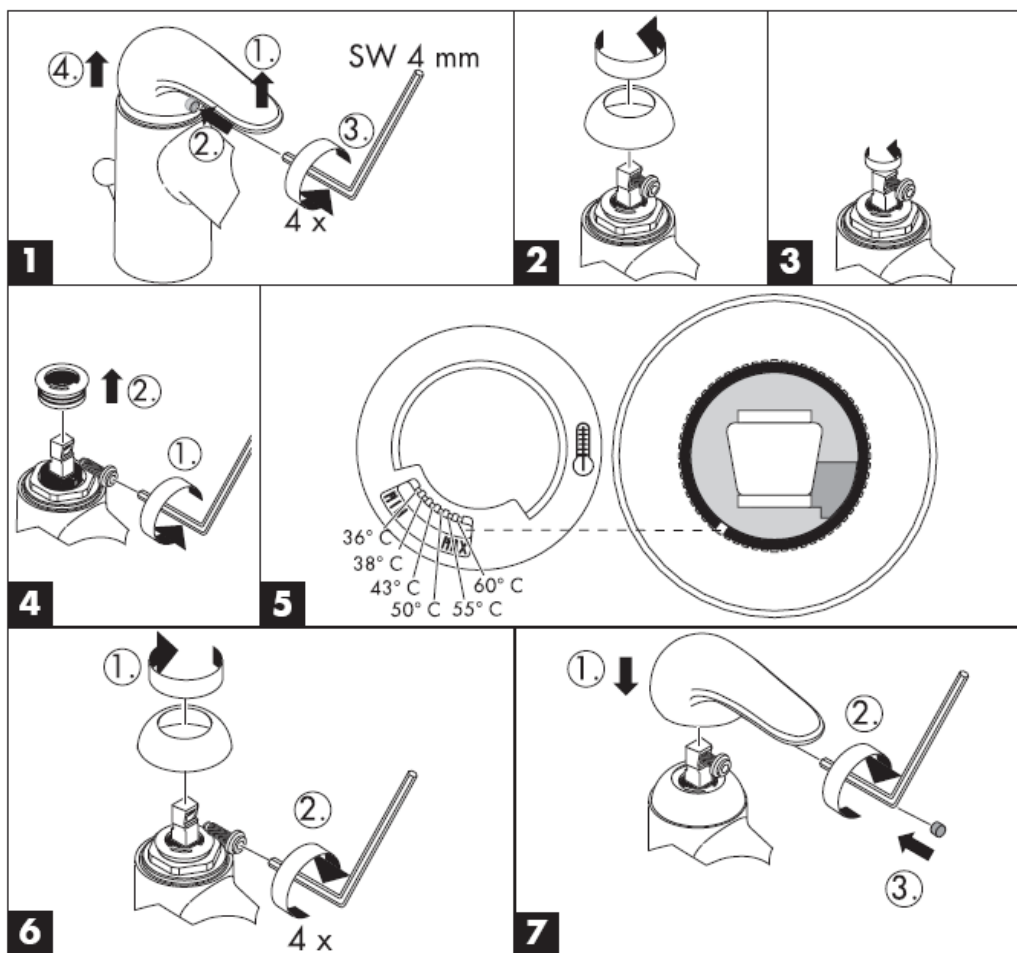

Tisztítás

A Rubit® manuális tisztítófunkciónak köszönhetően a vízsugárnylások egyszerű ledörzsöléssel megtisztíthatóak a vízkőtől.



hansgrohe

Hansgrohe · Postfach 1145 · D-77761 Schiltach · Telefon +49 (0) 78 36/51-1282 · Telefax +49 (0) 7836/511440
E-Mail: info@hansgrohe.com · Internet: www.hansgrohe.com

05/2006
9.07956.04
Magyar

Asennusohje



Talis E

33001000/33002XXX/33006000
33007000/33008000/33011000



Talis E

33200XXX/33202XXX/33208000

hansgrohe

33001000

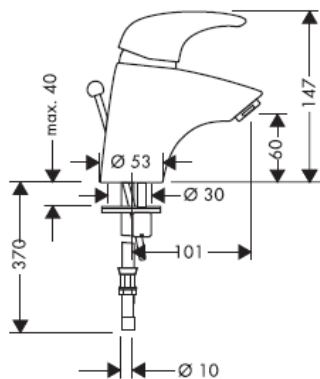

33200XXX

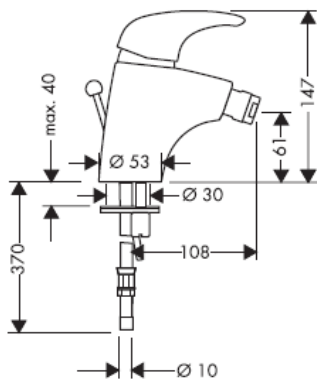

33002XXX

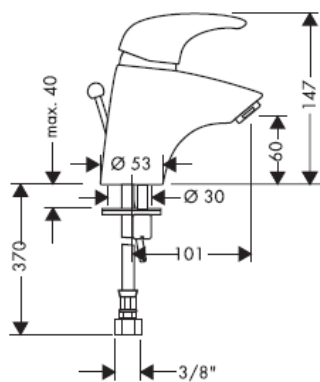

33202XXX

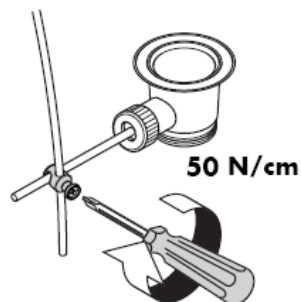
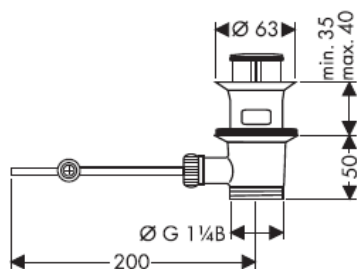
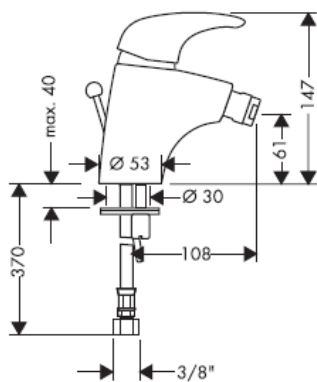

33008000

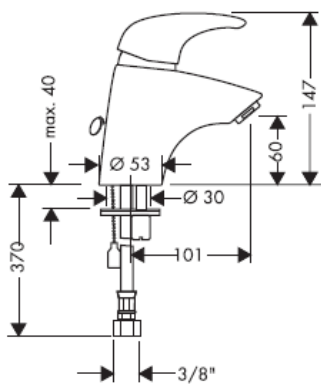

33208000

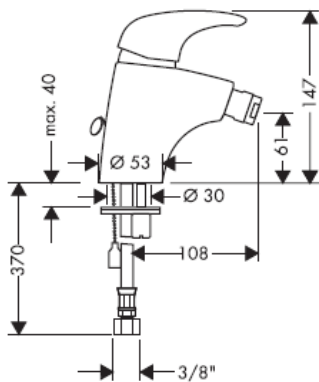

33006000

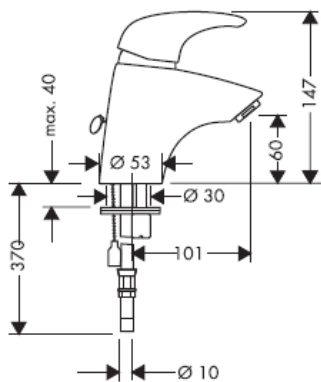

33007000

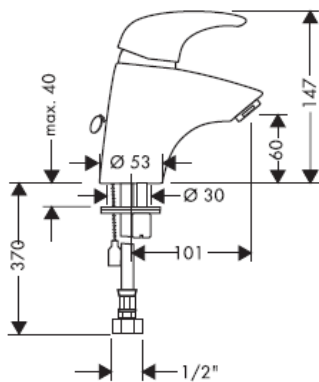

33011000

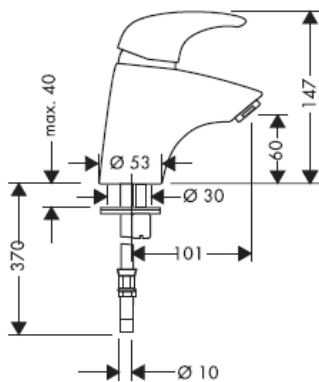

Liitäntäletkun asennus

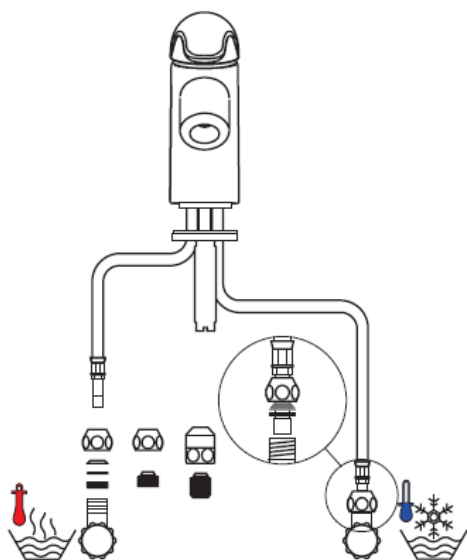
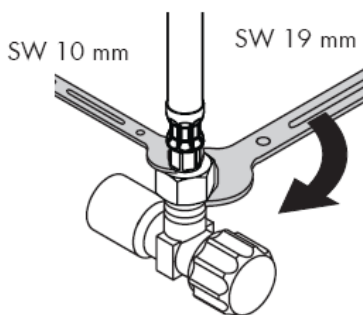
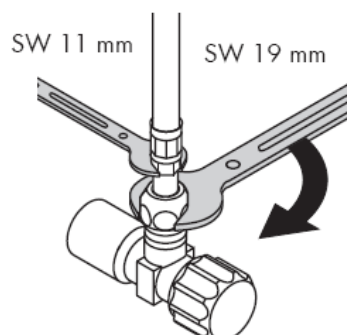
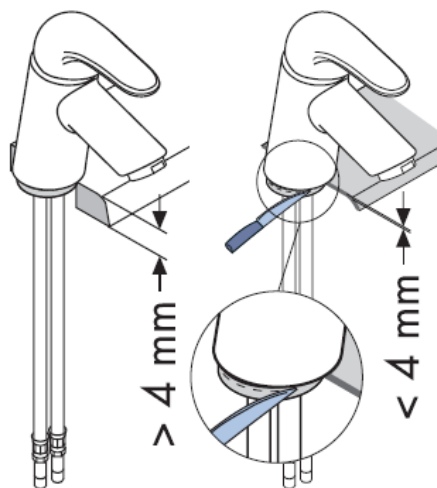
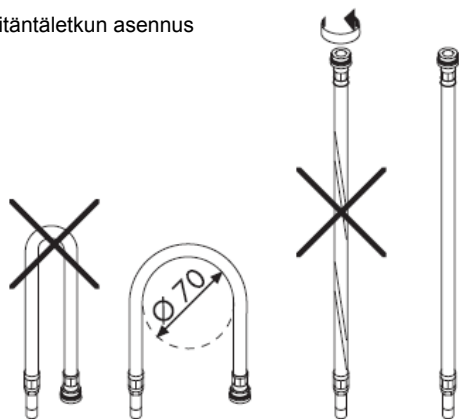

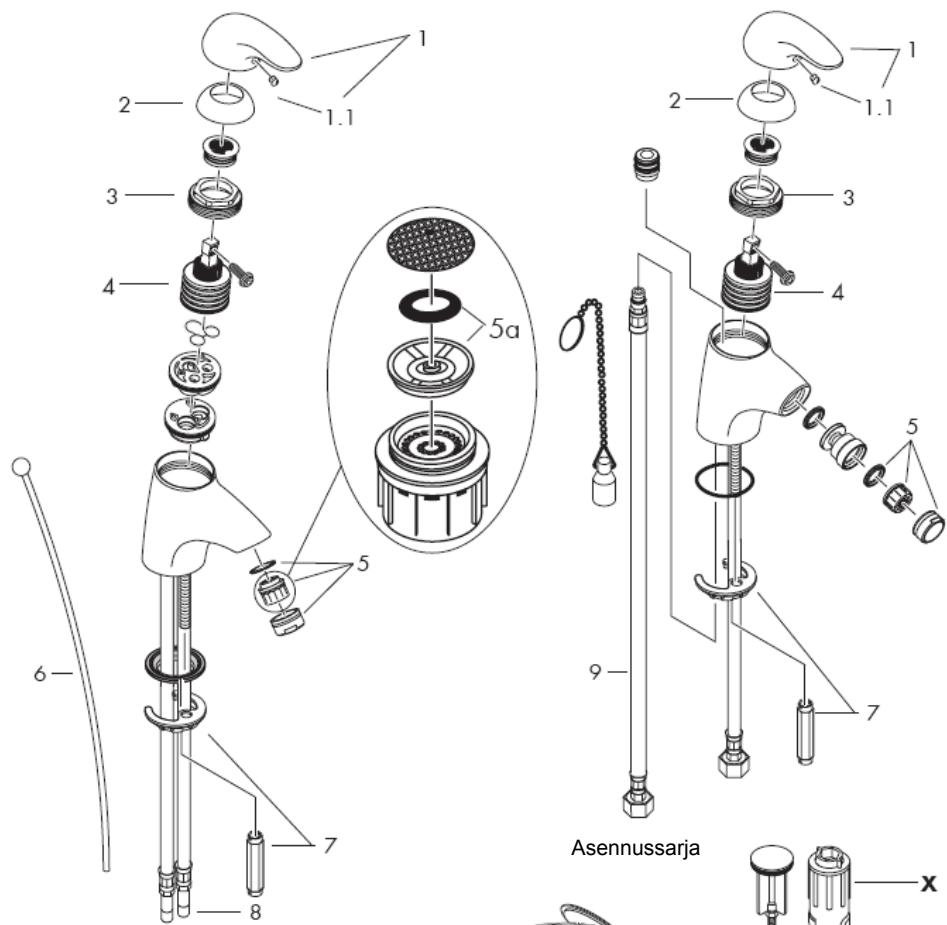

Asennussarja

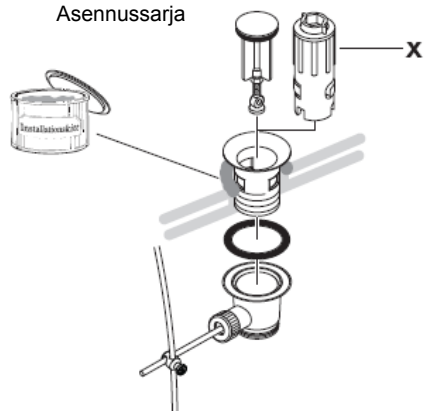

Huomio! Kaluste on asennettava, huuhdeltava ja tarkastettava voimassa olevien määräysten mukaisesti!

Asennus

- 1 Huuhtelee syöttöputken asianmukaisesti.
- 2 Aseta kaluste tiivisteeseen kanssa paikalleen pesupöytään / bideeseen.
- 3 Aseta aluslevy ja kiinnityslevy putkiliitosten ja kierretapin päälle ja kiristä mutterilla.
- 4 Liitä liitinletkut kulmaventtiileihin; kylmä oikealle - kuuma vasemmalle.
- 5 33001000/32002XXX/33200XXX/33202XXX: Yhdistä vetotanko pohjaventtiiliin.

Suuret paine-erot kylmä- ja kuumavesiliitännöiden välillä on tasattava.

Käyttö

Sekoittaja avataan kahvaa nostamalla.

Kääntö oikealle = kylmä vesi,

kääntö vasemmalle = lämmin vesi.

Tekniset tiedot

Kaluste on vakiona varustettu

Waterdimmer®:illä (virtauksen rajoittimella)

Läpivirtausmäärä Waterdimmer:iä käytettäessä:
7 l/min 0,3 MPa

Läpivirtausmäärä ilman Waterdimmer:iä:

12 l/min 0,3 MPa

Käyttöpaine: max. 1 MPa

Suosittelut käyttöpaine: 0,1 – 0,5 MPa

Koestuspaine: 1,6 MPa

(1 MPa = 10 bar = 147 PSI)

Kuuman veden suosituslämpötila: max 80° C

Kuuman veden suosituslämpötila: 60° C

Hansgrohe yksivipuisia sekoittimia voi käyttää hydraulisesti tai termisesti ohjattujen läpivirtauskuumentimien yhteydessä, jos virtauspaine on vähintään 0,15 MPa.

Jos läpivirtauskuumentimen kanssa on ongelmia tai, jos halutaan suurempaa veden virtausmäärää, voidaan poreenmuodostajan takana oleva Waterdimmer® (virtauksenrajoitin 5a) poistaa.

Yksivipuinen sekoittaja lämpimän veden rajoituksella, katso säätö sivulta 8. Lämpimän veden rajoitusta ei tarvita läpivirtauskuumentimen yhteydessä.

Varaosat katso sivu 5

1	Kahva	33091000
1.1	Kahvatulppa	94191000
2	Suojakuppi	94192000
	Suojakuppi kulta	94192990
3	Mutteri	94194000
4	Panos, täydellinen	92730000
5	Poresuutin, täydellinen (10)	13912000
	Poresuutin, täydellinen gold	94980990
	Poresuutin, täydellinen (6 l/min)	96788000
6	Vetotanko	92620000
	Vetotanko kultaoptiikka	92620990
7	Kiristyslevy ja mutteri	96016000
8	Liitinletku	95001000
9	Liitinletku	97206000

Erityisvaruste

X asennusavainsetti 58085000 (ei kuulu toimitukseen)

Suomi

Koestusmerkki

	DVGW	P-IX	SVGW	ACS	NF	WRAS	KIWA
33001000	X	P-IX 8388/IA	X			X	X
33002XXX	X	P-IX 8388/IA	X		X		X
33006000	X	P-IX 8388/IA	X				X
33007000							
33008000	X	P-IX 8388/IA	X		X		X
33011000							
33200XXX	X	P-IX 8388/IA	X			X	X
33202XXX	X	P-IX 8388/IA	X		X		X
33208000	X	P-IX 8388/IA	X		X		X

Kuumanveden rajoitin: kuuman veden lämpötila 60 C, kylmän veden lämpötila 10 C, virtauspaine 0,3 MPa.

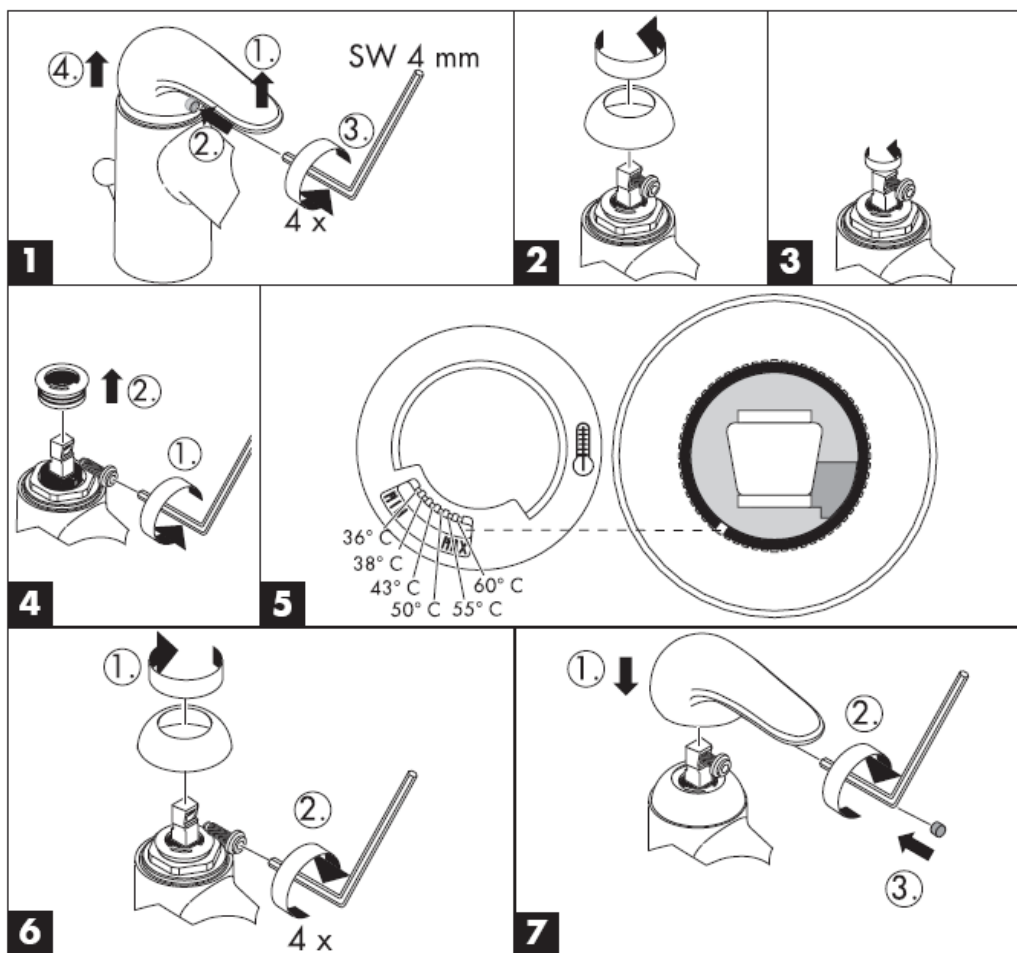

Puhdistus

Rubit® –käsitoiminen kalkinpoistojärjestelmä on helppo käyttää: hiero sormella ja vedentulo on taas esteetön.



hansgrohe

Hansgrohe · Postfach 1145 · D-77761 Schiltach · Telefon +49 (0) 78 36/51-1282 · Telefax +49 (0) 7836/511440
E-Mail: info@hansgrohe.com · Internet: www.hansgrohe.com

05/2006
9.07956.04
Suomi

Monteringsanvisning



Talis E

33001000/33002XXX/33006000
33007000/33008000/33011000



Talis E

33200XXX/33202XXX/32208000

hansgrohe

33001000

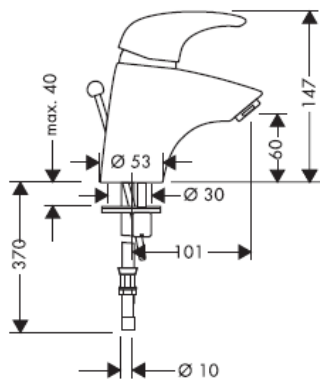

33200XXX

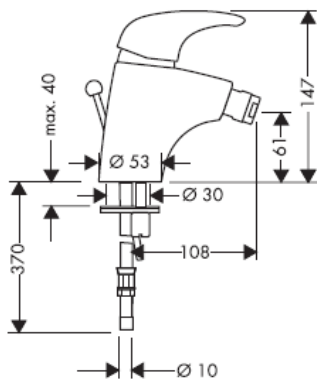

33002XXX

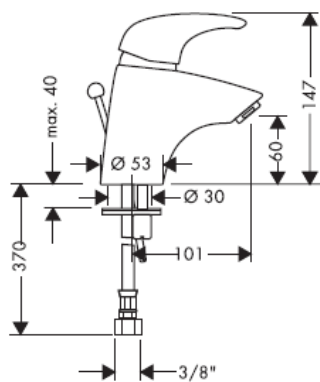

33202XXX

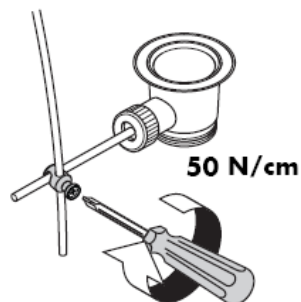
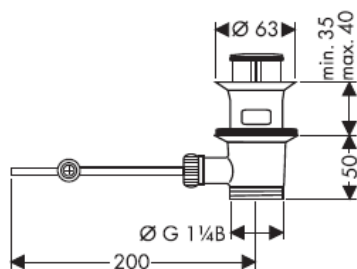
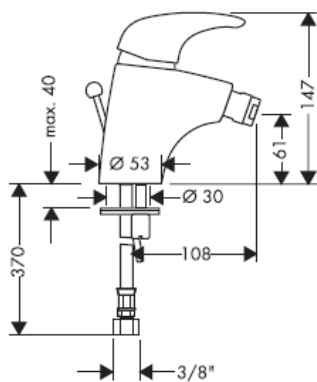

33008000

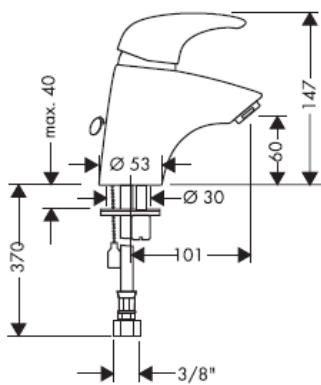

33208000

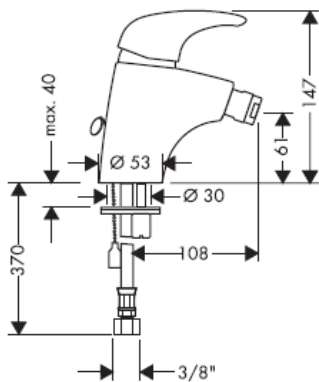

33006000

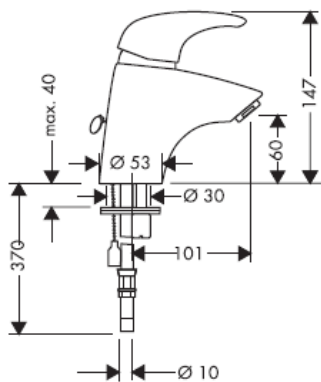

33007000

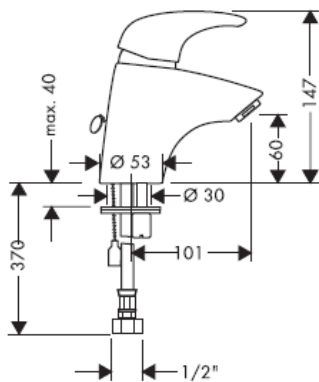

33011000

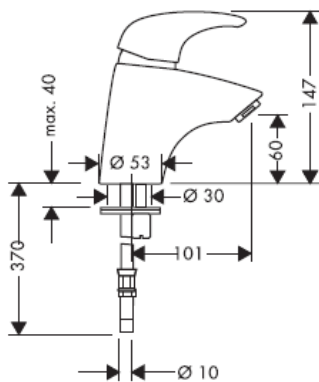

Montering anslutningslang

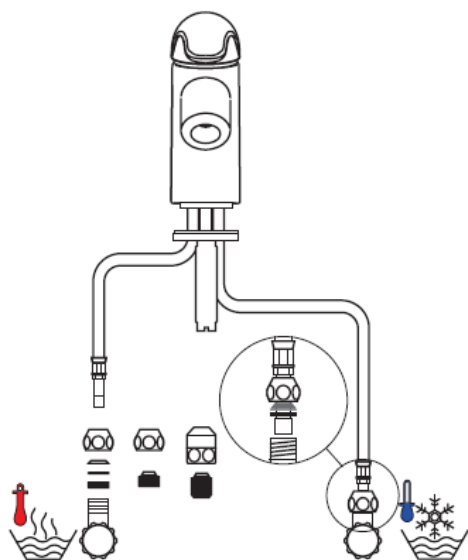
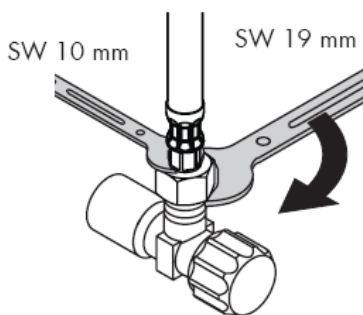
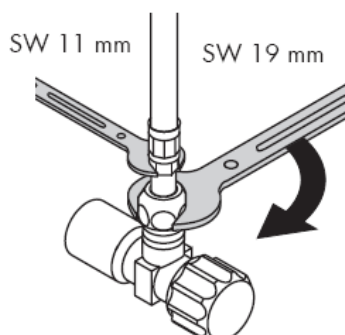
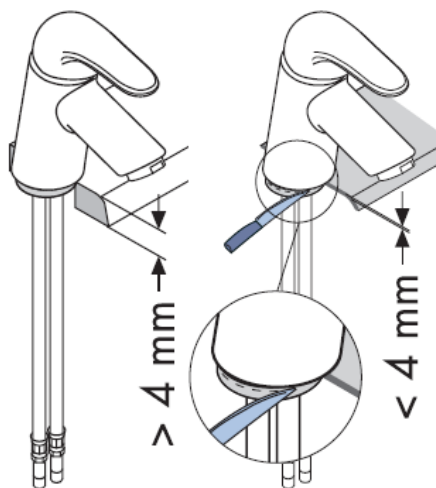
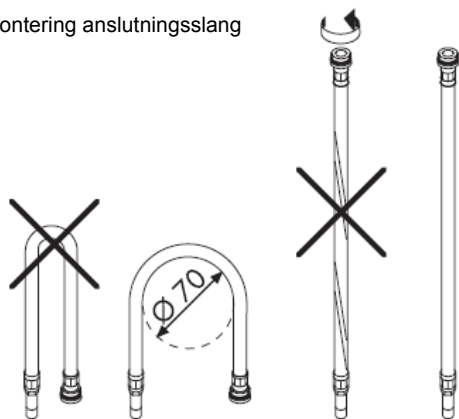

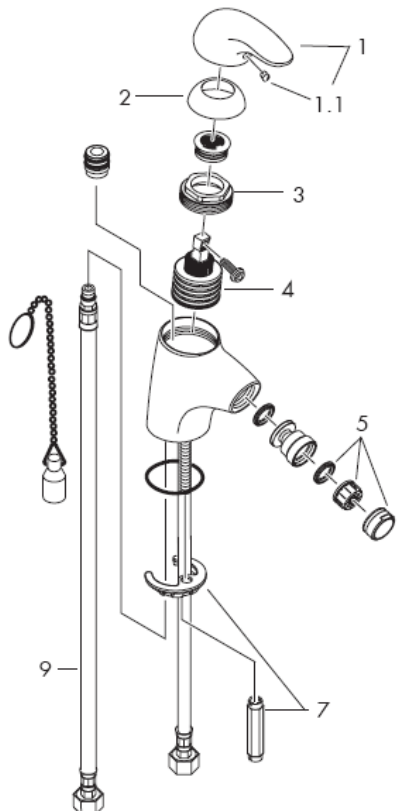
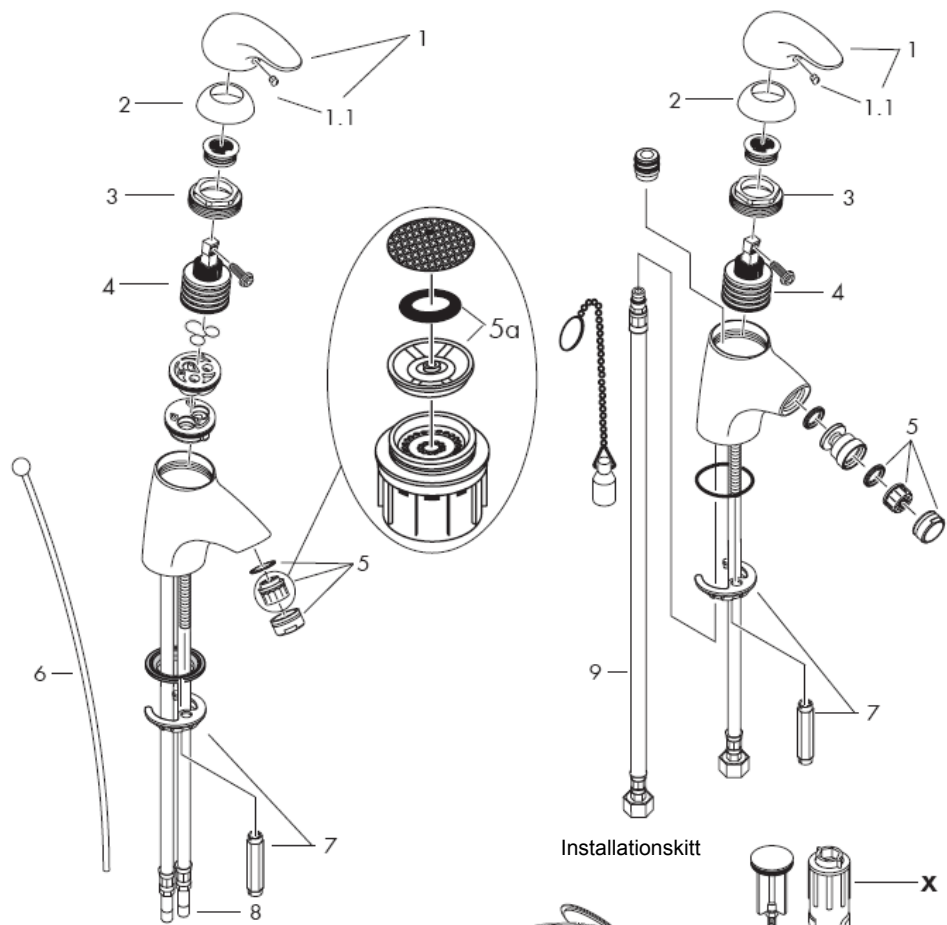

Installationskit

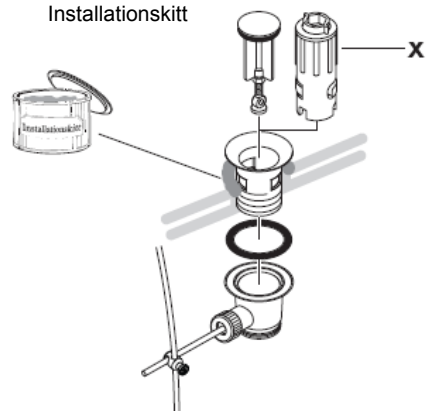

OBS! Blandaren måste installeras, genomspolas och testas enligt gällande föreskrifter.

Montering

- 1 Sköj tillförselledningarna noga.
- 2 Placera blandare med mellanläggsbricka i tvättställ / bidé.
- 3 Skjut mellanläggsbricka och fästbricka över anslutningsrör och gängstift och drag fast med mutter.
- 4 Koppla anslutningsslangar till hörnventiler, kallt höger – varmt vänster.
- 5 33001000/32002XXX/33200XXX/
33202XXX: Förbind dragstång med tömningsventil.

Stora tryckskillnader mellan anslutningarna för varmt och kallt vatten måste utjämnas.

Hantering

Genom att lyfta på greppet öppnas blandaren.
Sväng till höger = varmt vatten
Sväng till vänster = kallt vatten

Tekniska data

Blandare seriemässigt med Waterdimmer® (flödeskontroll).

Genomströmningsskapacitet med Waterdimmer:
7 l/min 0,3 MPa

Genomströmningsskapacitet utan Waterdimmer:
12 l/min 0,3 MPa

Driftstryck: max. 1 MPa

Rek. driftstryck: 0,1 – 0,5 MPa

Tryck vid provtryckning: 1,6 MPa

(1 MPa = 10 bar = 147 PSI)

Rek. varmvattentemp.: max 80° C

Rek. varmvattentemp.: 60° C

Hansgrohe enhandsblandare kan användas tillsammans med hydrauliskt och termiskt styrda varmvattenberedare när flödestrycket uppgår till minst 0,15 MPa.

Om det är problem med vattenberedaren eller om större vattenflöde önskas kan Waterdimmer® (flödeskontroll 5a) som sitter bakom perlatorn tas bort.

Enhandsblandare med varmvattenreglering, justering se sidan 8. Vid användning tillsammans med varmvattenberedare behövs ingen varmvattenreglering.

Reservdelar se sidan 5

1	Grepp	33091000
1.1	Greppstopp	94191000
2	Skydd	94192000
	Skydd guld	94192990
3	Mutter	94194000
4	Patron kompl.	92730000
5	Komplett perlator (10)	13912000
	Komplett perlator gold	94980990
	Komplett perlator (6 l/min)	96788000
6	Dragstång	92620000
	Dragstång	92620990
7	Stagmontering	96016000
8	Anslutningsslang	95001000
9	Anslutningsslang	97206000

Specialtillbehör

X monteringsnyckelset 58085000
(medföljer inte leveransen)

Svenska

Testsigill

	DVGW	P-IX	SVGW	ACS	NF	WRAS	KIWA
33001000	X	P-IX 8388/IA	X			X	X
33002XXX	X	P-IX 8388/IA	X		X		X
33006000	X	P-IX 8388/IA	X				X
33007000							
33008000	X	P-IX 8388/IA	X		X		X
33011000							
33200XXX	X	P-IX 8388/IA	X			X	X
33202XXX	X	P-IX 8388/IA	X		X		X
33208000	X	P-IX 8388/IA	X		X		X

Varmvattenreglering: Varmvattentemperatur 60 C, Kallvattentemperatur 10 C, flödestryck 0,3 MPa.

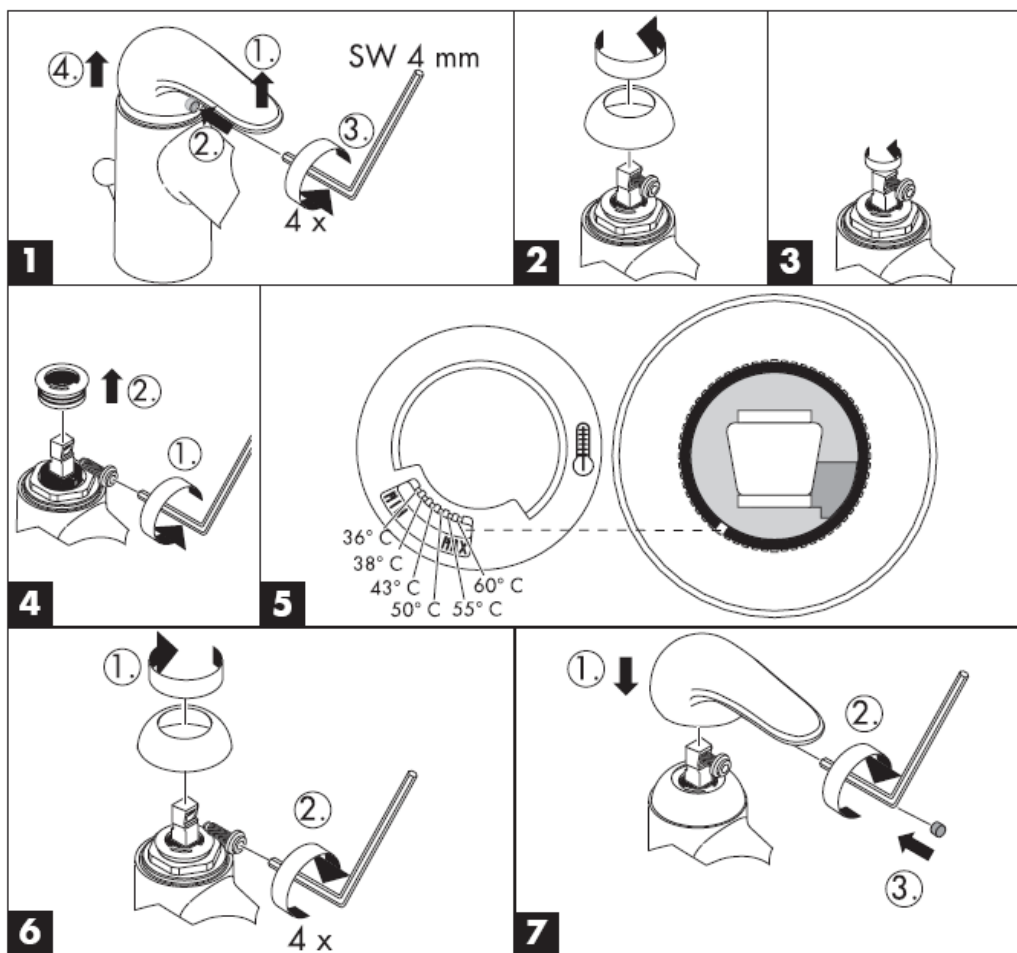

Rengöring

Med Rubit®, den manuella rengöringsfunktionen, är det lätt att befria strålkanalerna från kalk - de ska bar gnuggas.



hansgrohe

Hansgrohe · Postfach 1145 · D-77761 Schiltach · Telefon +49 (0) 78 36/51-1282 · Telefax +49 (0) 7836/511440
E-Mail: info@hansgrohe.com · Internet: www.hansgrohe.com

05/2006
9.07956.04
Svenska

Montavimo instrukcijos



Talis E

33001000/33002XXX/33006000
33007000/33008000/33011000



Talis E

33200XXX/33202XXX/33208000

hansgrohe

33001000

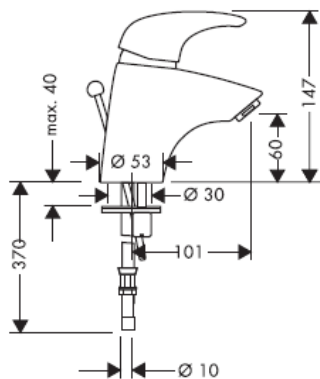

33200XXX

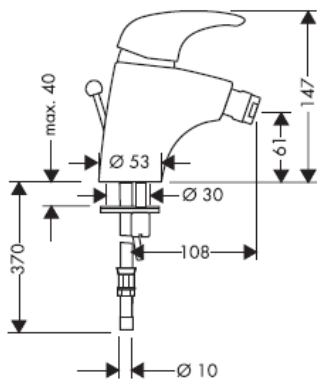

33002XXX

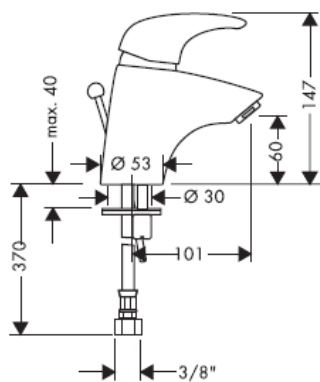

33202XXX

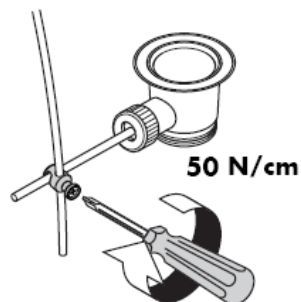
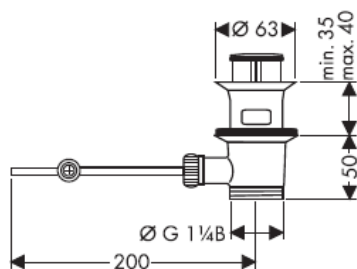
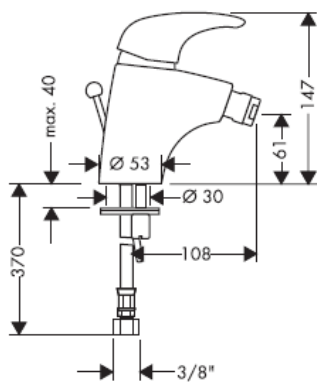

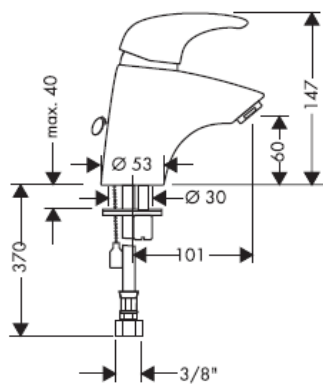
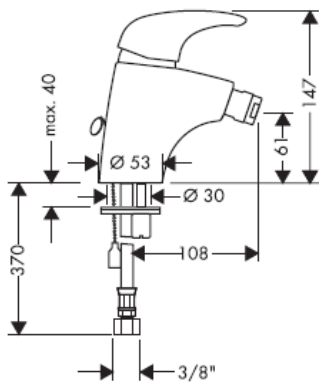
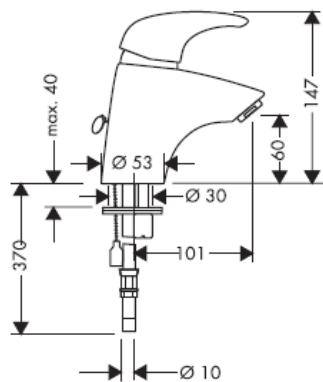
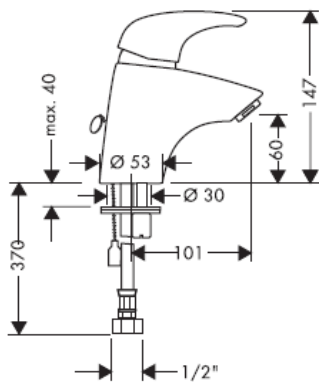
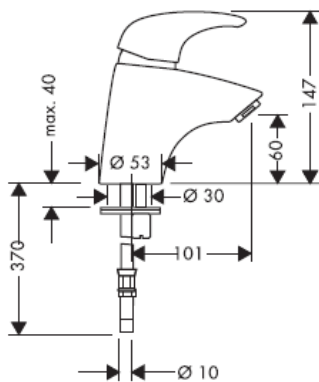
33008000**33208000****33006000****33007000****33011000**

Prijungimo žarnų montavimas

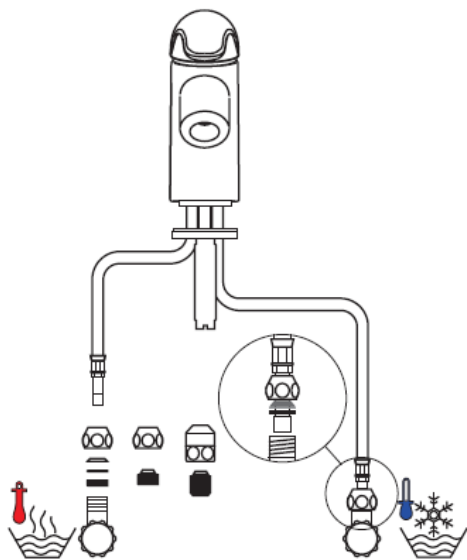
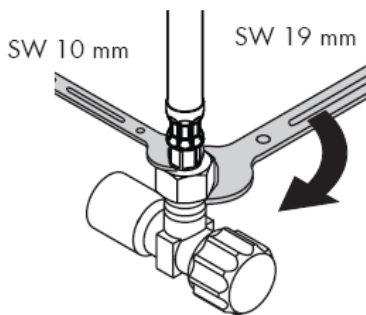
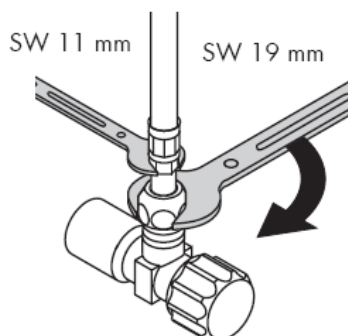
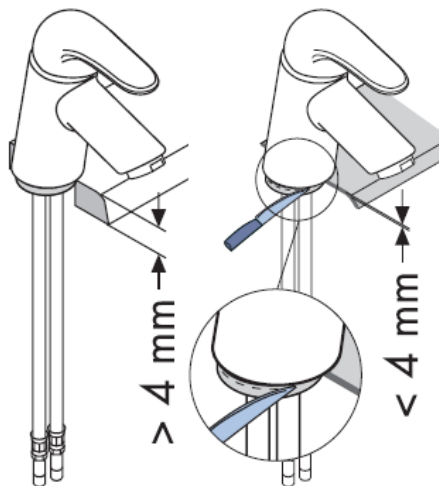
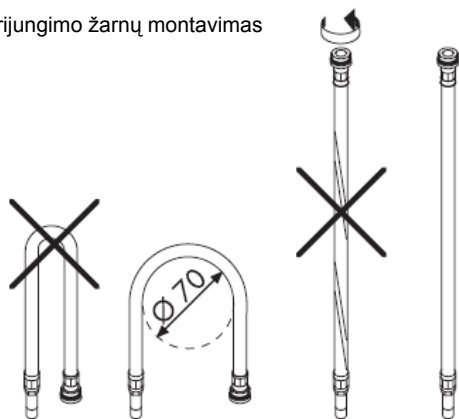

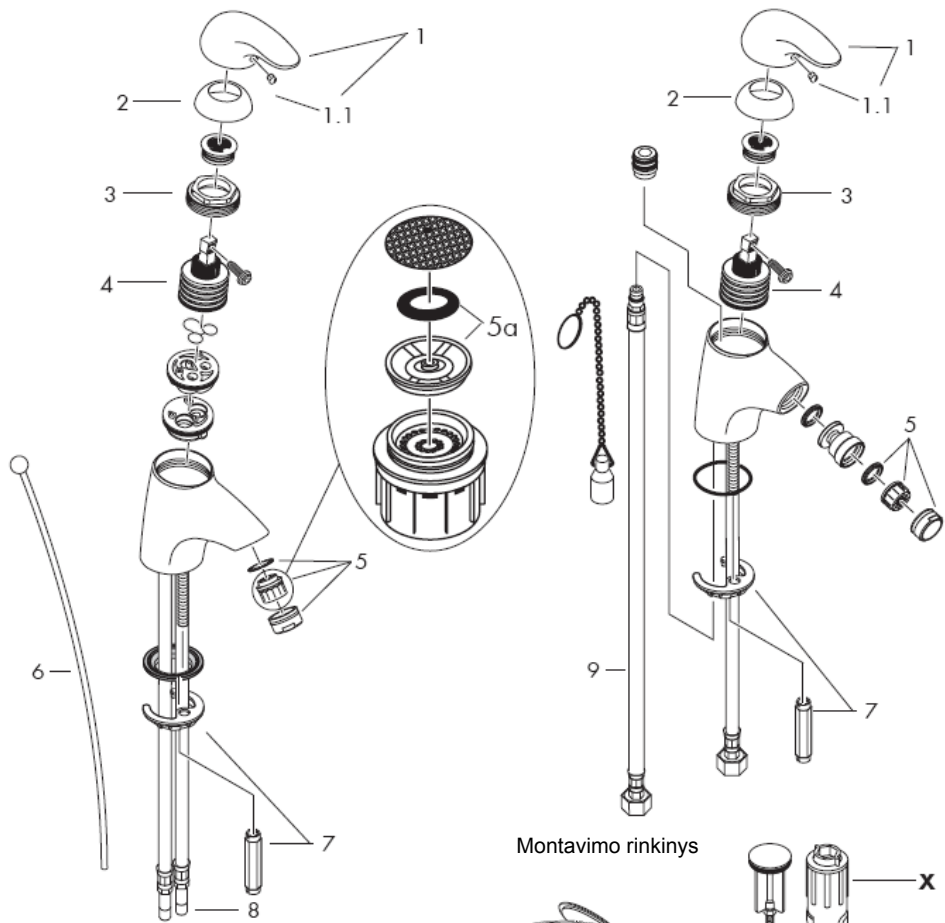

Montavimo rinkinys

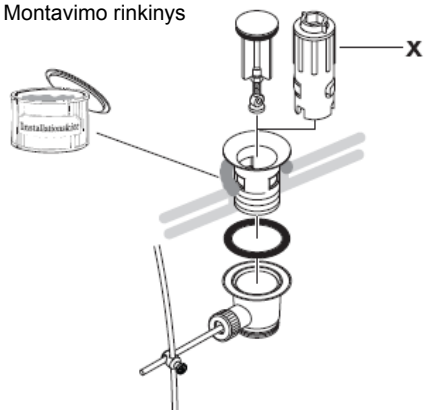

Dėmesio! Maišytuvas privalo būti montuojamas, išleidžiamas ir patikrinamas pagal galiojančias normas!

Montavimas

- 1 Išplauti vamzdžius.
- 2 Maišytuvą su tarpine įstatykite į kriauklę arba bide.
- 3 Uždėti sandariklį su veržle iš apačios ir prisukti.
- 4 Prijungimo žarnas prijunkite prie kampinių vožtuvų - šaltą dešinėje, karštą kairėje.
- 5 33001000/32002XXX/33200XXX/
33202XXX: Prijungti strypelį prie uždarymo vožtuvo.

Turi būti išlyginti šalto ir karšto slėgio nelygumai.

Eksplotacija

Maišytuvas atidaromas pakėlus rankenėlę. Pasukus rankenėlę į kairę, įjungiamas karštas vanduo; į dešinę - šaltas.

Techniniai duomenys

Šios serijos maišytuvai turi vandens tekėjimo ribotuvą "Waterdimmer®".

Vandens pralaidumas su oro kompresoriumi:
7 l/min 0,3 MPa

Vandens pralaidumas be oro kompresoriaus:
12 l/min 0,3 MPa

Darbinis slėgis: max. 1 MPa

Rekomenduojamas slėgis: 0,1 – 0,5 MPa

Bandomasis slėgis: 1,6 MPa

(1 MPa = 10 barų = 147 PSI)

Rekomenduojama karšto vandens temperatūra:
max 80° C

Rekomenduojama karšto vandens temperatūra:
60° C

"Hansgrohe" vienos rankenėlės maišytuvai gali būti naudojami su hidrauliškai ir termiškai reguliuojamais momentiniais šildikliais, kai vandens slėgis mažesnis kaip 0,15 MPa.

Jei yra problemų su momentiniu vandens šildikliu ar neužtenka vandens srauto, turi būti pašalintas už oro kompresoriaus esantis ribotuvas "Waterdimmer®" (5a).

Vienos rankenėlės maišytuvas turi karšto vandens ribotuvą (nustatymą žr. psl. 8). Naudojant momentinį šildiklį karšto vandens ribotuvus nebūtinai.

Atsarginės dalys žr. psl. 5

1	Rankenėlė	33091000
1.1	Dangtis	94191000
2	dangtis	94192000
	auksinis dangtis	94192990
3	veržlė	94194000
4	kasetė	92730000
5	oro kompresorius (10)	13912000
	oro kompresorius gold	94980990
	oro kompresorius (6 l/min)	96788000
6	Strypelis	92620000
	Strypelis aukso optika	92620990
7	fiksavimo rinkinys	96016000
8	Prijungimo žarna	95001000
9	Prijungimo žarna	97206000

Specialūs priedai

X specialus raktas maišytuvų remontui 58085000 (nekomplektuojamas)

Lietuviškai

Bandymo pažyma

	DVGW	P-IX	SVGW	ACS	NF	WRAS	KIWA
33001000	X	P-IX 8388/IA	X			X	X
33002XXX	X	P-IX 8388/IA	X		X		X
33006000	X	P-IX 8388/IA	X				X
33007000							
33008000	X	P-IX 8388/IA	X		X		X
33011000							
33200XXX	X	P-IX 8388/IA	X			X	X
33202XXX	X	P-IX 8388/IA	X		X		X
33208000	X	P-IX 8388/IA	X		X		X

Karšto vandens ribotuvas: karšto vandens temperatūra 60 C, šalto vandens - 10 C, slėgis 0,3 MPa..

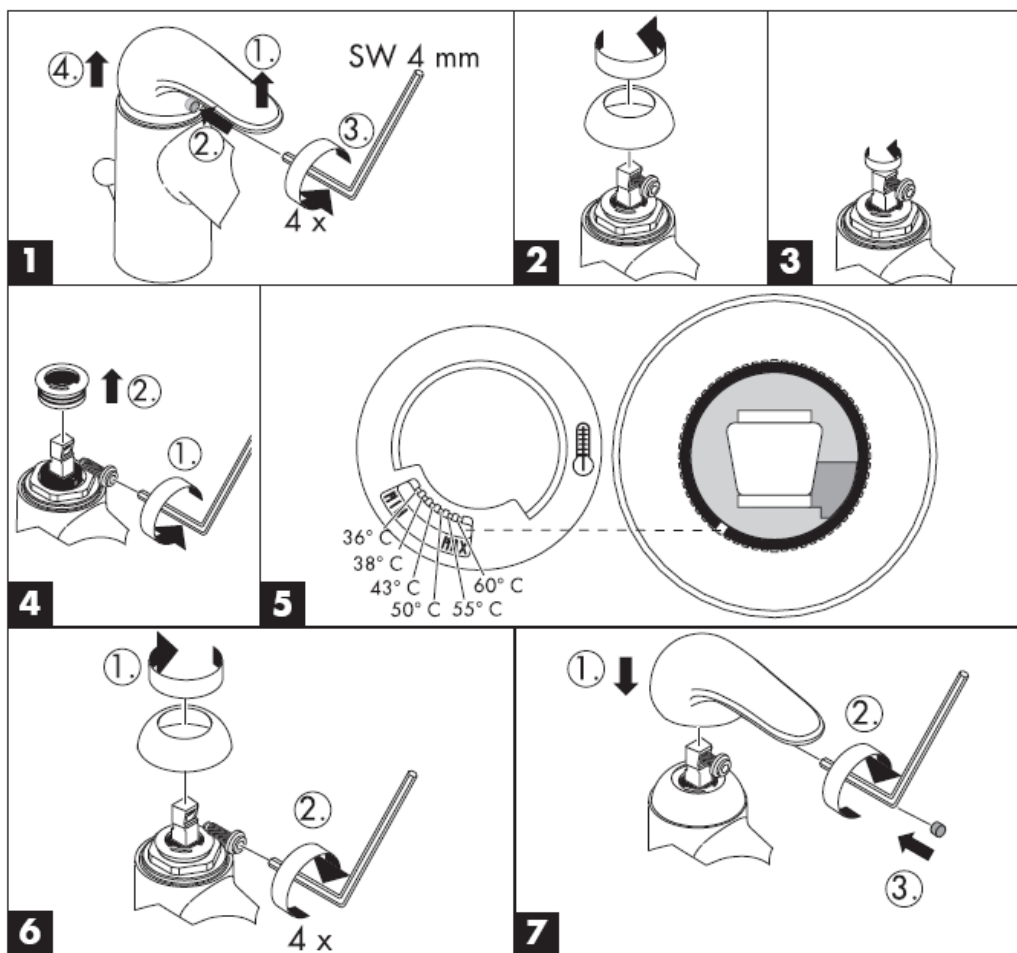

Valymas

"Rubit®" valymo funkcija apsaugo nuo apkalkėjimo.
Užtenka pirštu nubraukti atsiradusius nešvarumus
nuo srovės angų.



hansgrohe

Hansgrohe · Postfach 1145 · D-77761 Schiltach · Telefon +49 (0) 78 36/51-1282 · Telefax +49 (0) 7836/511440
E-Mail: info@hansgrohe.com · Internet: www.hansgrohe.com

05/2006
9.07956.04
Lietuviškai

Uputstva za instalaciju



Talis E

33001000/33002XXX/33006000
33007000/33008000/33011000



Talis E

33200XXX/33202XXX/33208000

hansgrohe

33001000

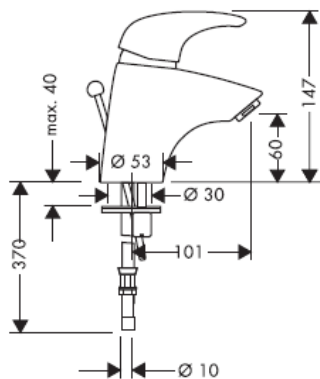

33200XXX

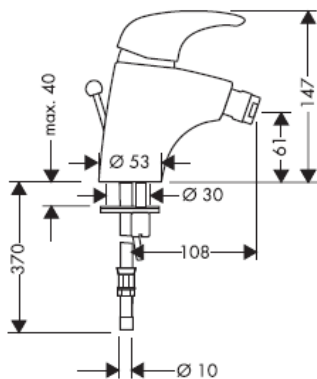

33002XXX

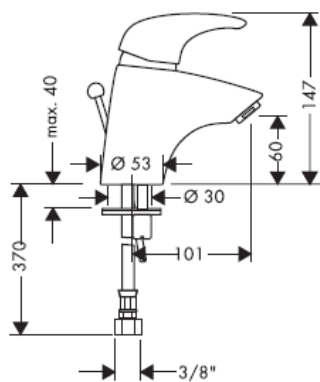

33202XXX

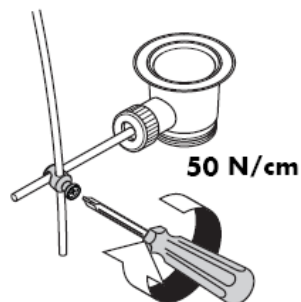
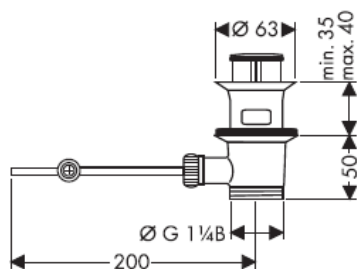
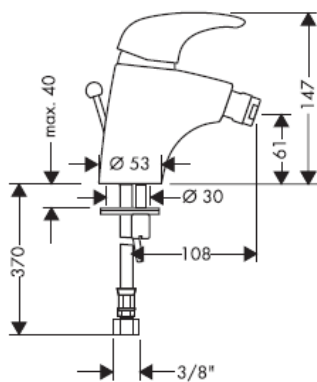

33008000

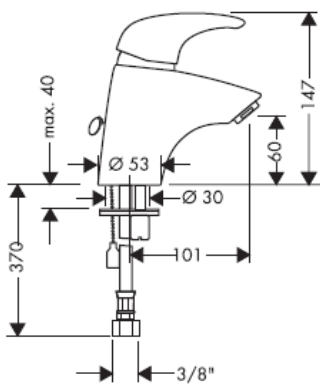

33208000

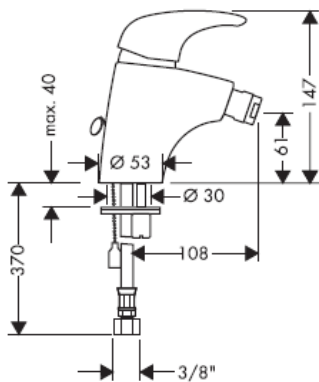

33006000

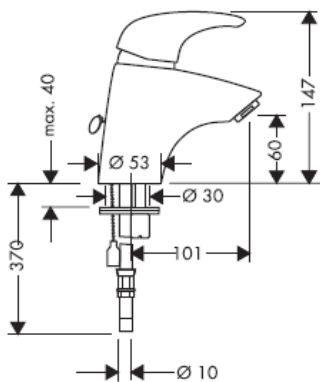

33007000

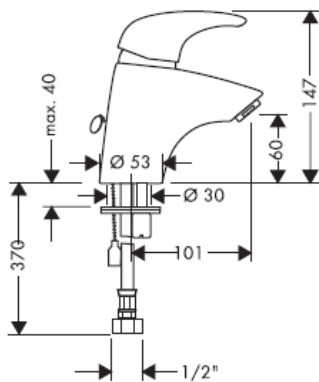

33011000

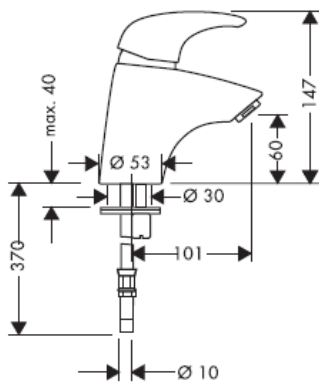

montaža priključne cijevi

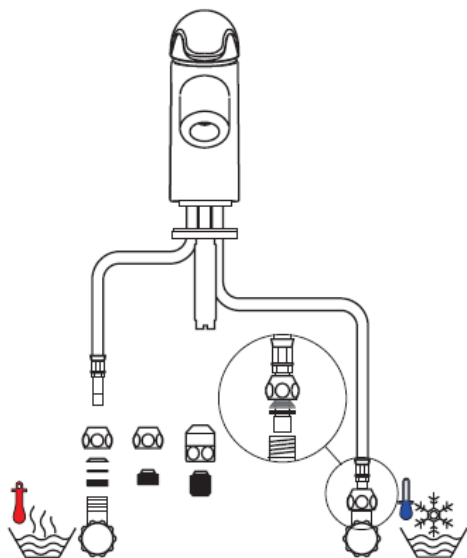
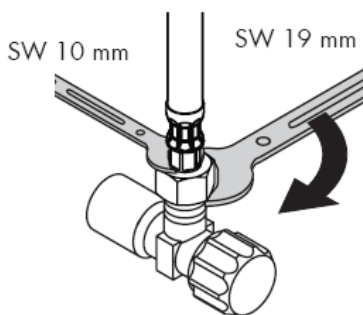
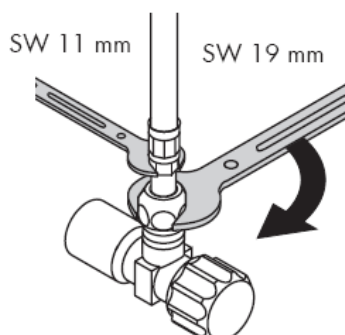
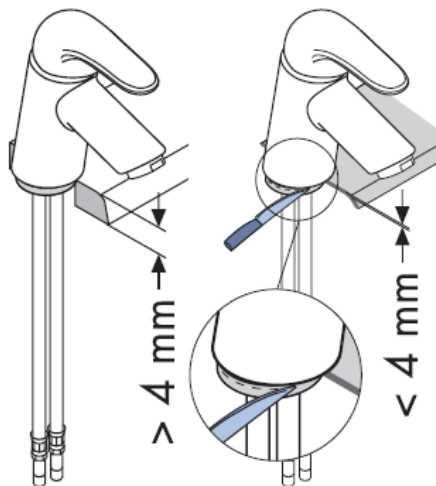
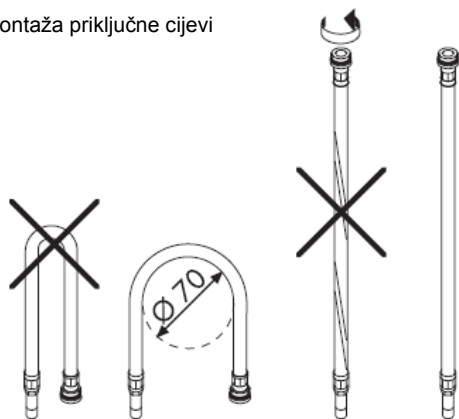

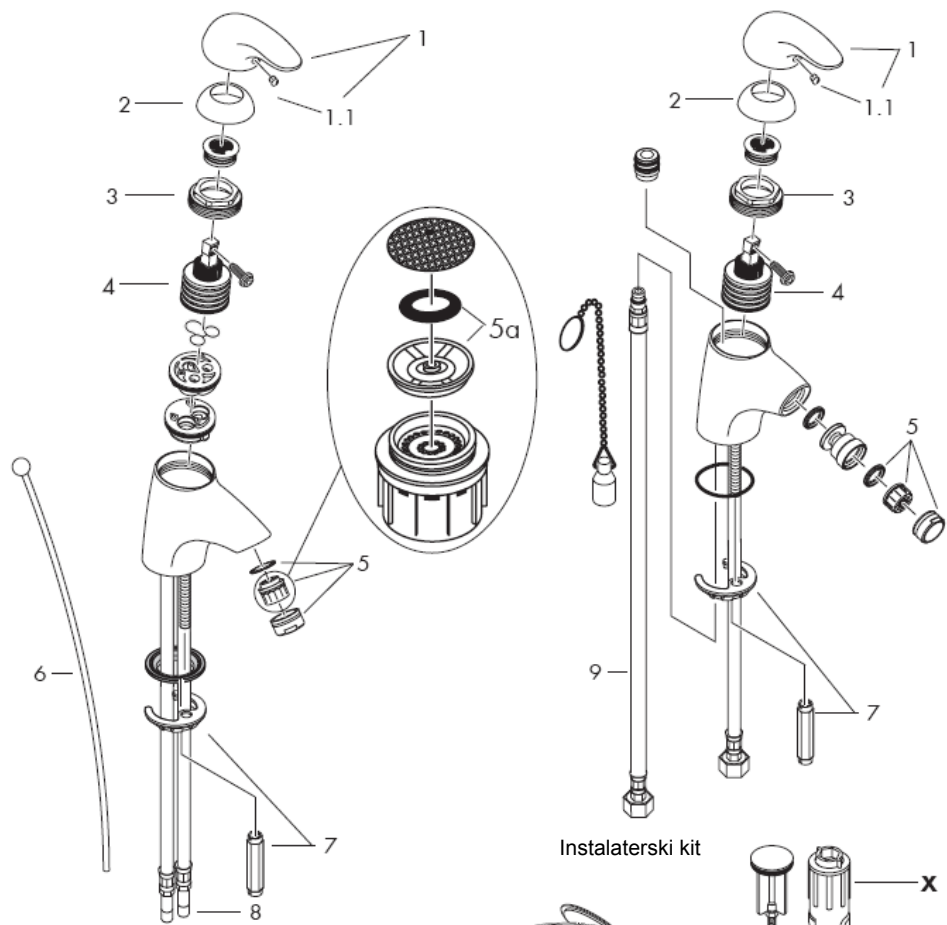

Instalaterski kit

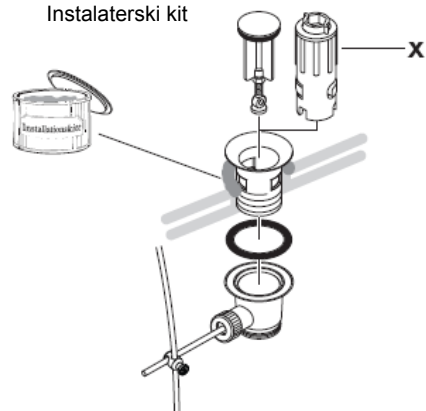

Pažnja! Cijevi moraju biti postavljene, isprane i testirane prema važećim normama!

Sastavljanje

- 1 Isperite cijevi dovoda.
- 2 Postavite slavinu uključujući i gumenu brtvu na umivaonik/bide.
- 3 Postavite dio za fiksiranje slavine i stegnite maticu.
- 4 Spojite fleksibilne dovodne cijevi na kutne ventile; hladna desno – vruća lijevo.
- 5 33001000/32002XXX/33200XXX/
33202XXX: Spojite šipku za zatvaranje dovoda na sifon.

Velika razlika u pritisku između vruće i hladne vode mora biti izbalansirana.

Upotreba

Slavina se otvara podizanjem ručice.
Okretanje ulijevo = vruća voda
Okretanje udesno = hladna voda

Tehnički podatci

Ova serija jednoručnih miješalica ima ugrađen limitator protoka vode.

Protok vode sa waterdimmer-om: 7 l/min 0,3 MPa

Protok vode bez waterdimmer-a: 12 l/min 0,3 MPa

Najveći dopušteni tlak: max. 1 MPa

Preporučeni tlak: 0,1 – 0,5 MPa

Probni tlak: 1,6 MPa

(1 MPa = 10 bar = 147 PSI)

Preporučena temperatura vruće vode: max 80° C

Preporučena temperatura vruće vode: 60° C

Hansgrohe jednoručne slavine se mogu koristiti sa hidrauličnim i termički kontroliranim protočnim bojlerima ako je tlak najmanje 0,15 MPa.

Ako dolazi do problema sa protočnim bojlerima ili ne izlazi dovoljno vode, waterdimmer® (5a) lociran iza perlatora mora biti uklonjen.

Da bi podesili limiter vruće vode na jednoručnim slavinama molimo Vas da pogledate stranicu 8. Podešavanje nije potrebno ako koristite protočni bojler.

Rezervni djelovi pogledaj stranicu 5

1	Ručica	33091000
1.1	Poklopac vijka	94191000
2	Zaštita mehanizma	94192000
	Pozlaćena zaštita mehanizma	94192990
3	Matica	94194000
4	Uložak	92730000
5	Aerator pozlaćeni (10)	13912000
	Aerator pozlaćeni gold	94980990
	Aerator pozlaćeni (6 l/min)	96788000
6	Šipka za zatvaranje odvoda	92620000
	Šipka za zatvaranje odvoda optika zlato	92620990
7	Matica za učvršćivanje slavine	96016000
8	Dovodna cijev	95001000
9	Dovodna cijev	97206000

Posebni pribor

X set instalacijskih ključeva 58085000 (nije sadržano u isporuci)

Hrvatski

Oznaka testiranja

	DVGW	P-IX	SVGW	ACS	NF	WRAS	KIWA
33001000	X	P-IX 8388/IA	X			X	X
33002XXX	X	P-IX 8388/IA	X		X		X
33006000	X	P-IX 8388/IA	X				X
33007000							
33008000	X	P-IX 8388/IA	X		X		X
33011000							
33200XXX	X	P-IX 8388/IA	X			X	X
33202XXX	X	P-IX 8388/IA	X		X		X
33208000	X	P-IX 8388/IA	X		X		X

Limitér vruće vode: temperatura vruće vode 60 C, temperatura hladne vode 10 C, tlak 0,3 MPa.

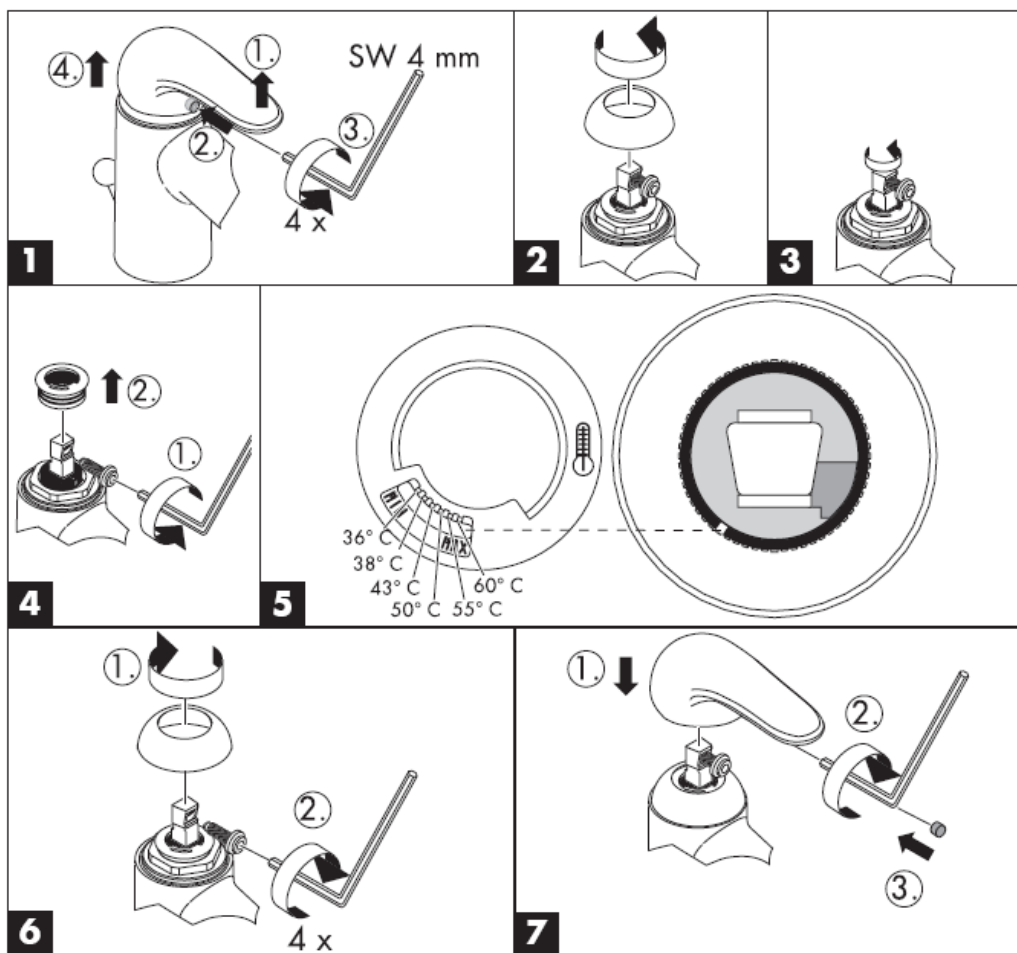

Čišćenje

Rubit® - ručni sustav za čišćenje omogućuje jednostavnim trljanjem odstranjivanje kamenca sa rupica prskalice tuša.



hansgrohe

Hansgrohe · Postfach 1145 · D-77761 Schiltach · Telefon +49 (0) 78 36/51-1282 · Telefax +49 (0) 7836/511440
E-Mail: info@hansgrohe.com · Internet: www.hansgrohe.com

05/2006
9.07956.04
Hrvatski

Montaj kılavuzu



Talis E

33001000/33002XXX/33006000
33007000/33008000/33011000



Talis E

33200XXX/33202XXX/33208000

hansgrohe

33001000

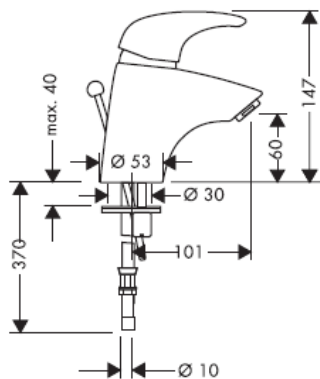

33200XXX

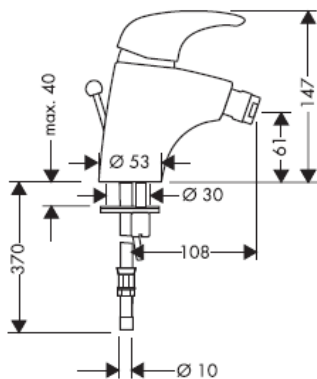

33002XXX

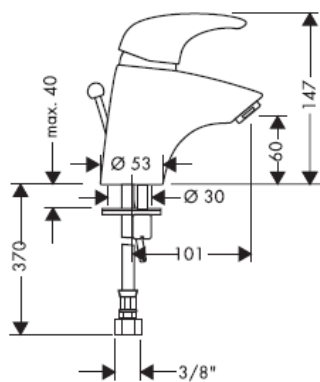

33202XXX

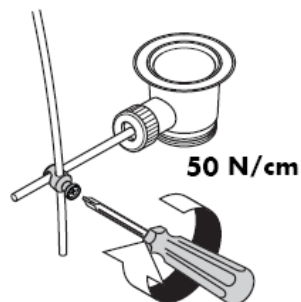
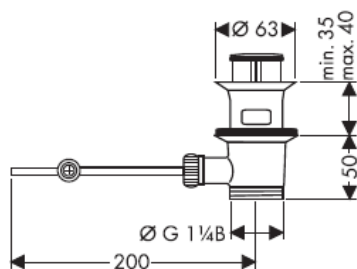
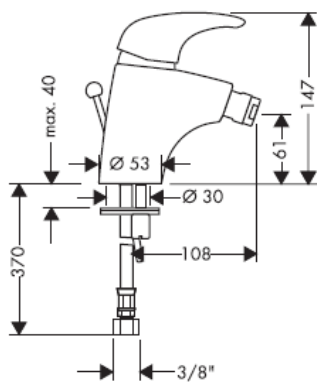

33008000

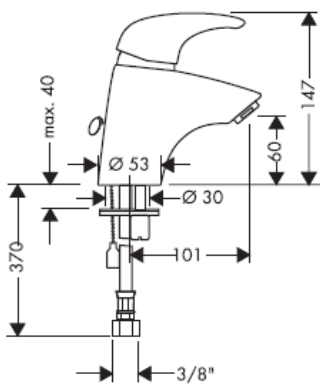

33208000

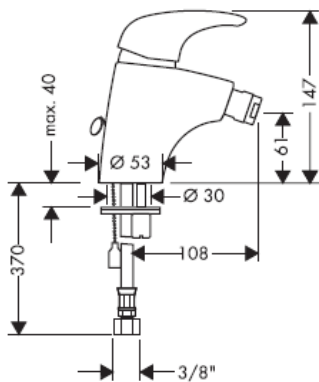

33006000

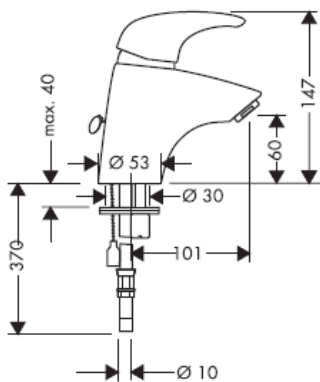

33007000

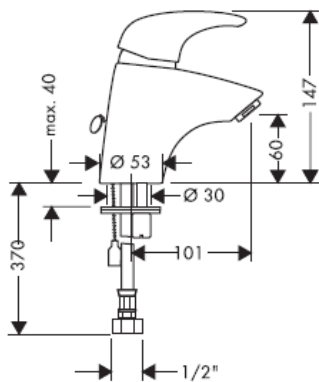

33011000

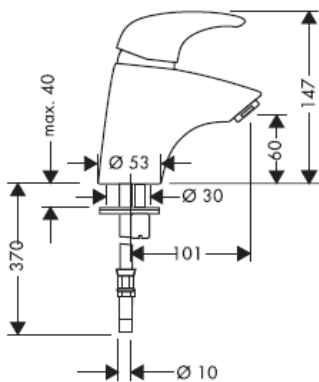

Bağlantı hortumunun montajı

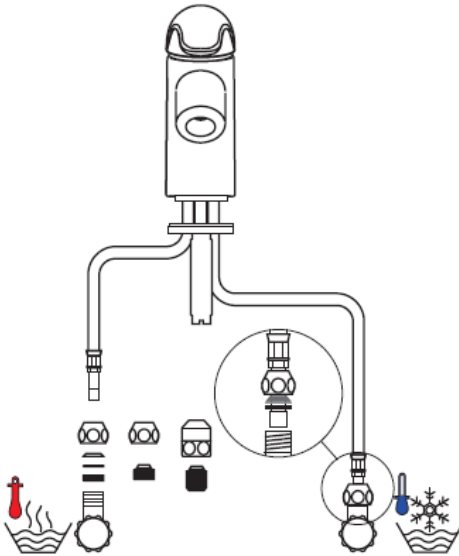
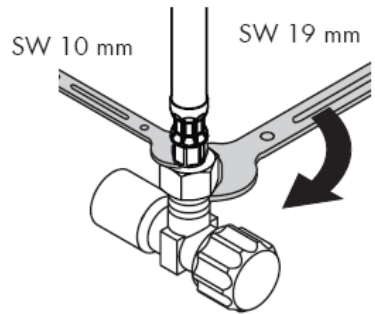
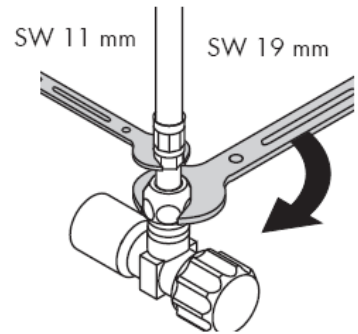
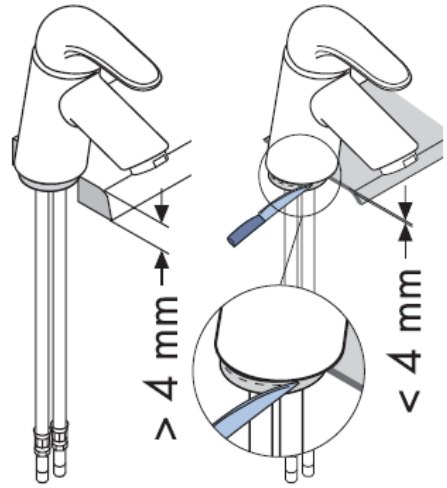
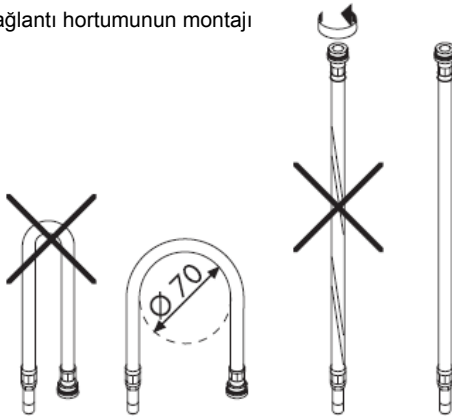

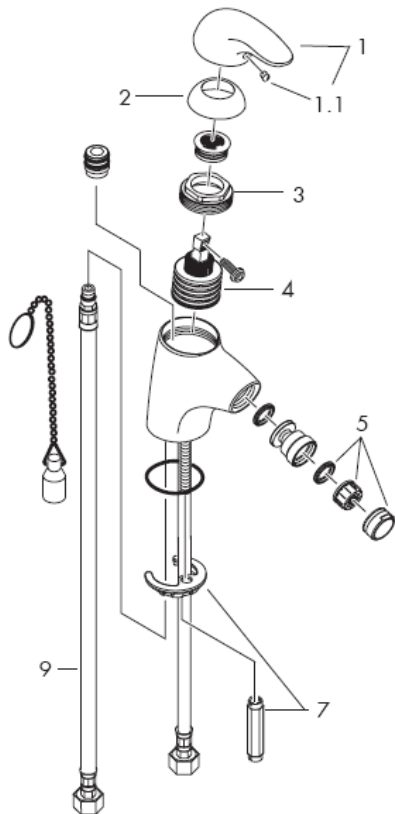
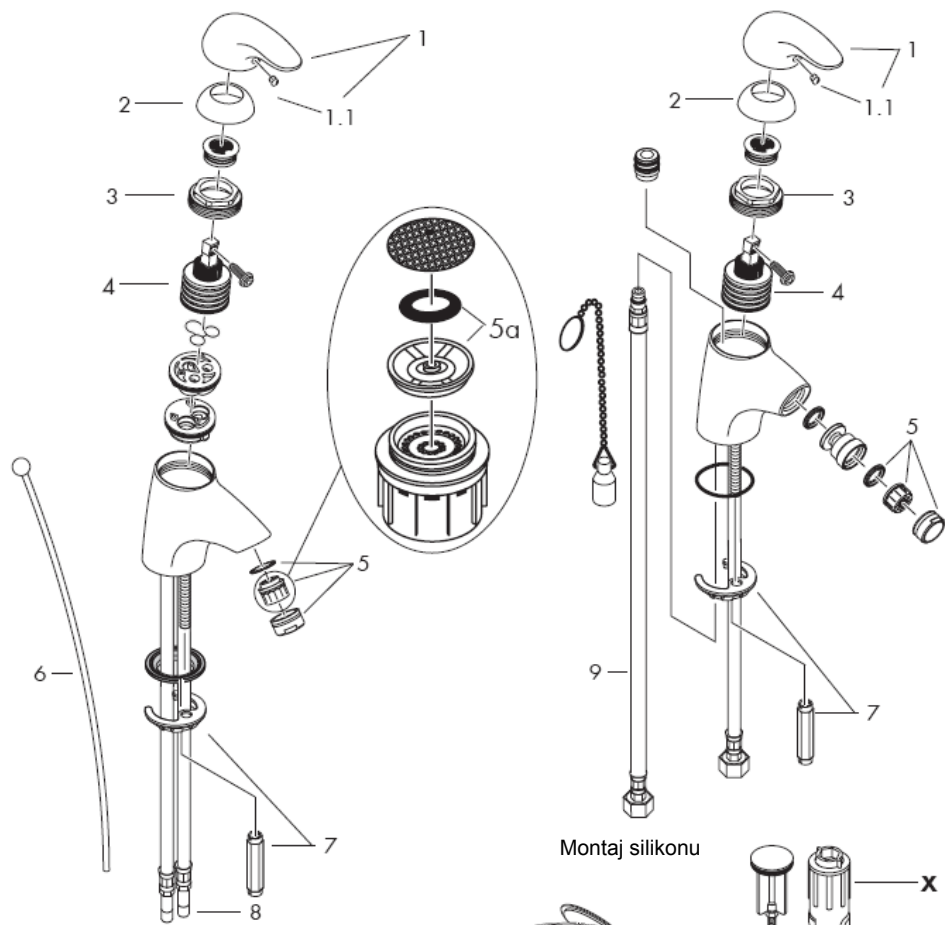

Montaj silikonu

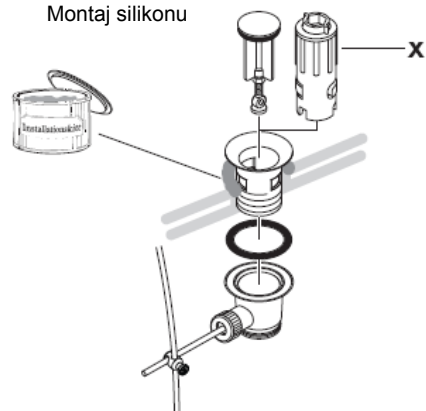

Önemli! Batarya geçerli normlara göre monte edilmeli, yıkanmalı ve kontrol edilmelidir!

Montajı

- 1 Su giriş hatlarından su akıtarak boruları iyice temizleyiniz.
- 2 Bataryayı ara birim ile birlikte lavaboya / küvete / bideye monte ediniz.
- 3 Sızdırmazlık contasını ve montaj pulunu bağlantı hortumlarının ve dişli vida pimin üzerinden geçirin ve somun ile iyice sıkınız.
- 4 Bağlantı hortumlarını ara musluklara bağlayınız. Soğuk sağ tarafa sıcak sol tarafa.
- 5 33001000/32002XXX/33200XXX/33202XXX: Tıkaç kumanda çubuğunu sifona bağlayınız.

Sıcak ve soğuk su bağlantıları arasında büyük basınç farklılıkları varsa, bu basınç farklılıklarının dengelenmesi gerekir.

Kullanımı

Musluk kolunu yukarıya doğru kaldırıncaya mikser batarya açılır.
Gövdede ki kolu sola çevrildiğinde = sıcak su,
Gövdede ki kolu sağa çevrildiğinde = soğuk su.

Teknik bilgiler

Batarya dizi halinde waterdimmer® (akış sınırlayıcısı)

Debisi (akış sınırlayıcısı ile):

7 l/min 0,3 MPa

Debisi (akış sınırlayıcısız):

12 l/min 0,3 MPa

İşletme basıncı: max. 1 MPa

Tavsiye edilen işletme basıncı: 0,1 – 0,5 MPa

Kontrol basıncı: 1,6 MPa

(1 MPa = 10 bar = 147 PSI)

Tavsiye edilen su ısı: max 80° C

Tavsiye edilen su ısı: 60° C

Su akış basıncı en azından 0,15 MPa olan yerlerde Hansgrohe tek kollu bataryalarını, hidrolik ve termik kumandalı şofbenlerle birlikte kullanabilirsiniz.

Sürekli akışlı su ısıtıcıları ile birlikte kullanımında problemler söz konusu ise veya akan su miktarının daha fazla olması isteniyorsa, perlatörün arka tarafındaki akış sınırlayıcısı (5a) sökülüp çıkarılabilir.

Sıcak su sınırlayıcı özelliğine sahip tek kollu bataryanın ayarlanması için 8. sayfaya bakınız. Bir sürekli akışlı su ısıtıcısı ile birlikte kullanılırsa sıcak su sınırlayıcısına gerek kalmaz.

Yedek Parçalar Bakınız sayfa 5

1	Kumanda kolu	33091000
1.1	Vida tıpası	94191000
2	Ayna	94192000
	Ayna Altın	94192990
3	Somun	94194000
4	Kartuş	92730000
5	Perlatör (10)	13912000
	Perlatör gold	94980990
	Perlatör (6 l/min)	96788000
6	Kumanda Çubuğu	92620000
	Kumanda Çubuğu altın-optik	92620990
7	Montaj elemanı	96016000
8	Bağlantı hortumu	95001000
9	Bağlantı hortumu	97206000

Özel aksesuarlar

X Montaj için anahtar Seti 58085000
(Teslimat kapsamına dahil değildir)

Türkçe

Kontrol işareti

	DVGW	P-IX	SVGW	ACS	NF	WRAS	KIWA
33001000	X	P-IX 8388/IA	X			X	X
33002XXX	X	P-IX 8388/IA	X		X		X
33006000	X	P-IX 8388/IA	X				X
33007000							
33008000	X	P-IX 8388/IA	X		X		X
33011000							
33200XXX	X	P-IX 8388/IA	X			X	X
33202XXX	X	P-IX 8388/IA	X		X		X
33208000	X	P-IX 8388/IA	X		X		X

Sıcak su sınırlaması: Sıcak su sıcaklığı 60 C, soğuk su sıcaklığı 10 C, akma basıncı 0,3 MPa.

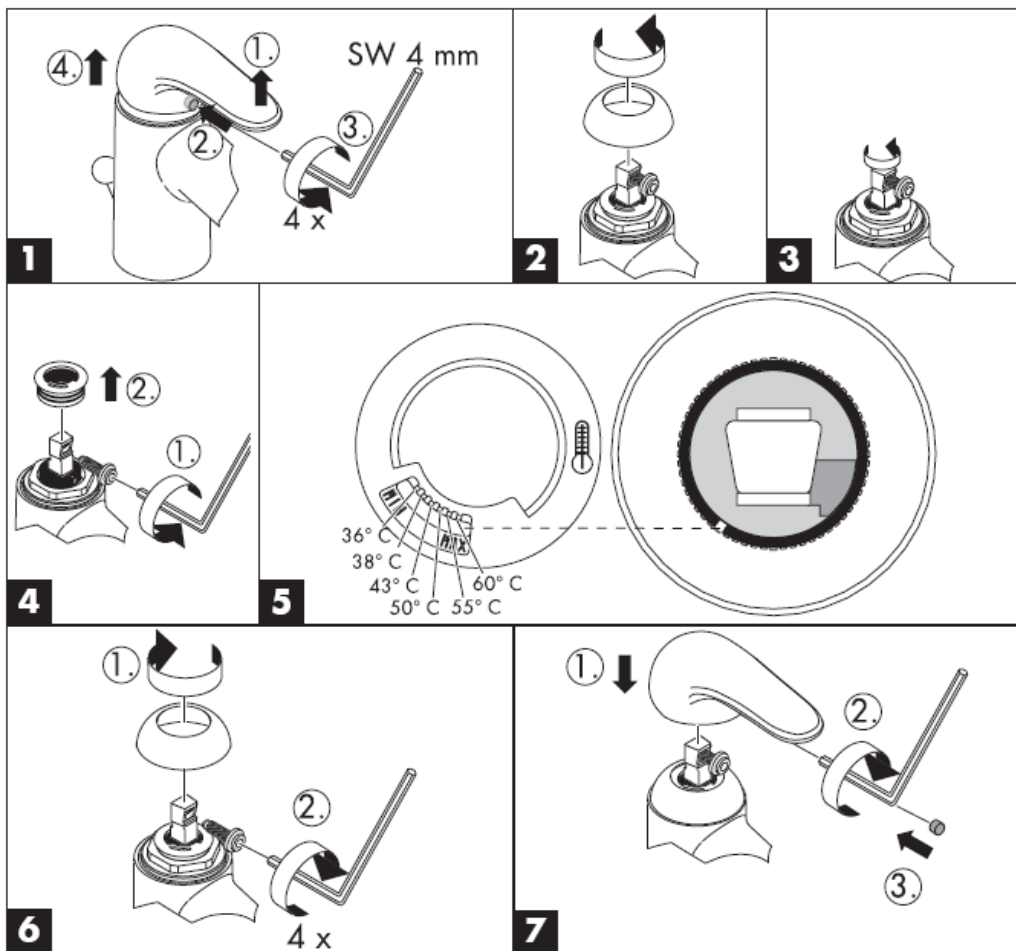

Temizleme

Rubit®, üründe bulunan bir temizleme fonksiyonudur. Basit bir ovuşturma ile sprey modüllerdeki kireci çözer.



hansgrohe

Hansgrohe · Postfach 1145 · D-77761 Schiltach · Telefon +49 (0) 78 36/51-1282 · Telefax +49 (0) 7836/511440
E-Mail: info@hansgrohe.com · Internet: www.hansgrohe.com

05/2006
9.07956.04
Türkçe

Instrucțiuni de montare



Talis E

33001000/33002XXX/33006000
33007000/33008000/33011000



Talis E

33200XXX/33202XXX/33208000

hansgrohe

33001000

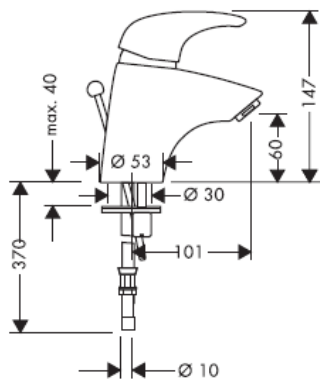

33200XXX

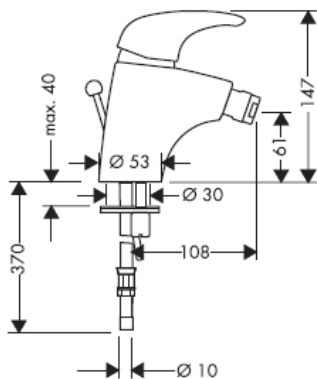

33002XXX

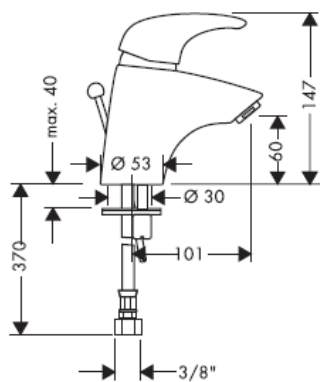

33202XXX

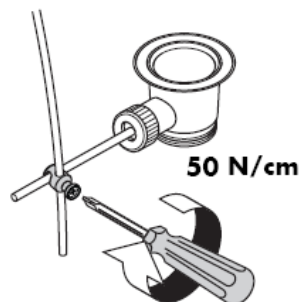
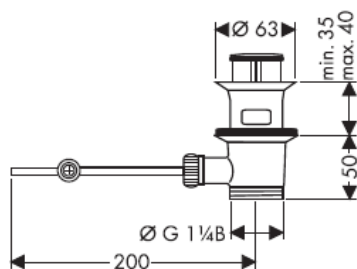
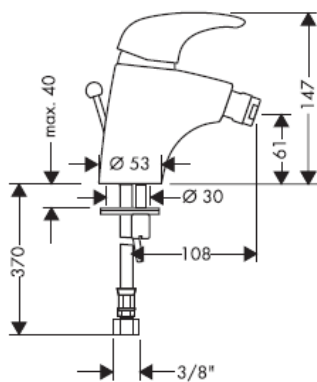

33008000

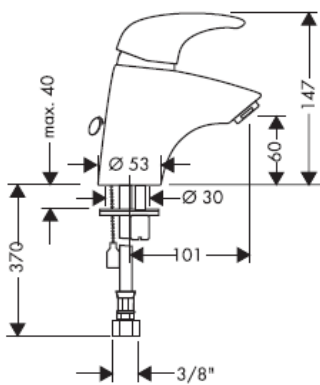

33208000

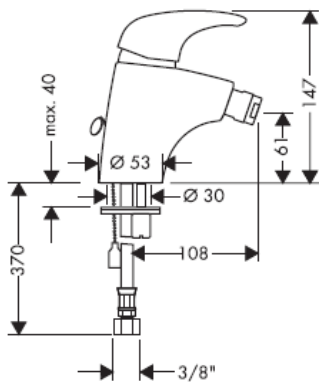

33006000

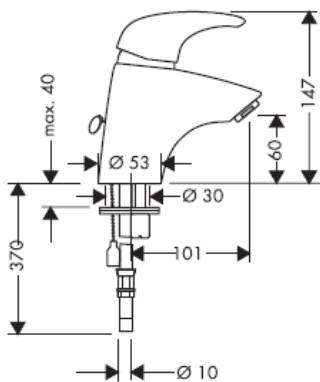

33007000

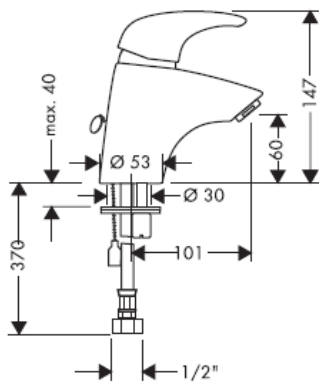

33011000

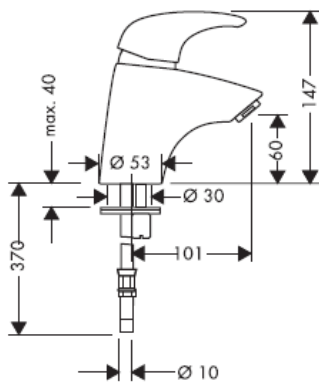

Montarea furtunului de racord

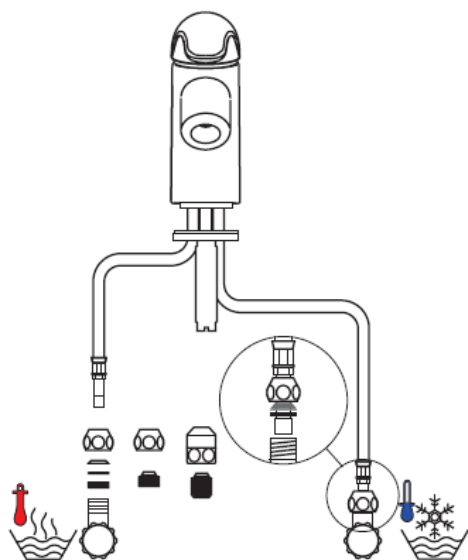
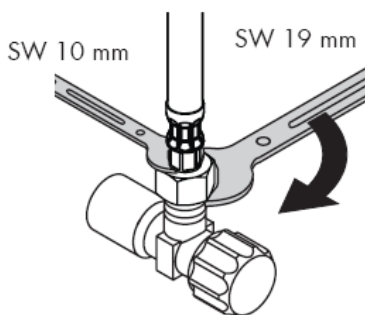
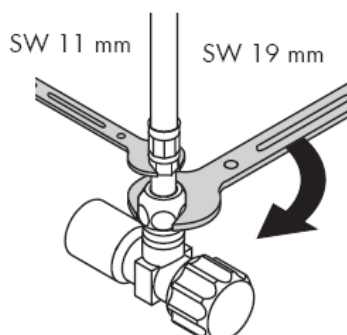
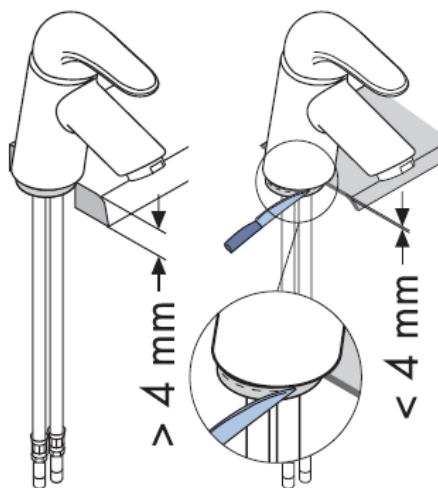
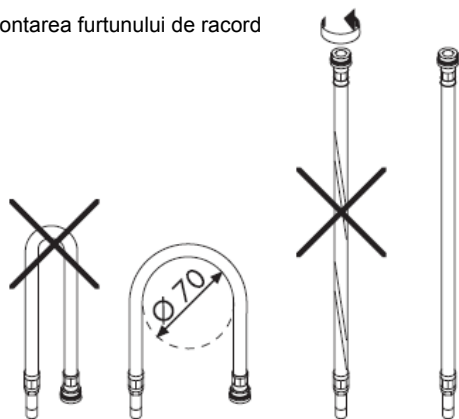

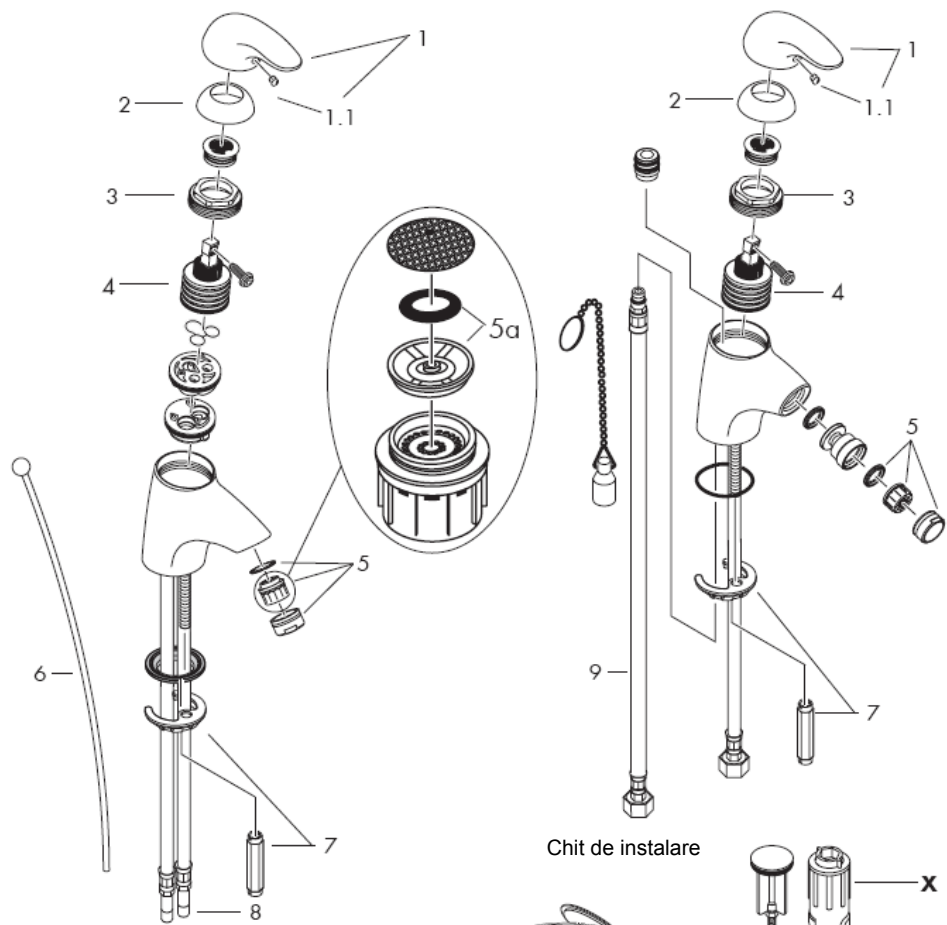

Chit de instalare

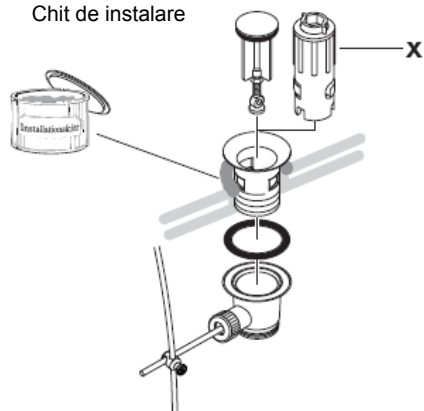

Atenție! Bateria trebuie montată, clătită și verificată conform normelor în vigoare.

Montare

- 1 Clătiți conductele de alimentare în mod profesional.
- 2 Așezați bateria cu garnitura din cauciuc pe lavoar / bideu.
- 3 Puneți garnitura și inelul de fixare pe țevile de conectare și știftul filetat și strângeți piulița.
- 4 Conectați furtunurile de racordare la ventilele de colț: cald - stânga / rece - dreapta.
- 5 33001000/32002XXX/33200XXX/
33202XXX: Conectați maneta de tragere cu ventilul de scurgere.

Diferențele de presiune mari între alimentarea cu apă rece și apă caldă trebuie echilibrate.

Utilizare

Deschideți bateria prin ridicarea manetei.
Rotire spre stânga = apă caldă,
rotire spre dreapta = apă rece.

Date tehnice

Bateria este dotată în serie cu reductor de debit Waterdimmer®.

Debit de apă cu Waterdimmer: 7 l/min 0,3 MPa

Debit de apă fără Waterdimmer: 12 l/min 0,3 MPa

Presiune de funcționare: max. 1 MPa

Presiune de funcționare recomandată: 0,1 – 0,5 MPa

Presiune de verificare: 1,6 MPa
(1 MPa = 10 bar = 147 PSI)

Temperatura recomandată a apei calde: max 80° C

Temperatura recomandată a apei calde: 60° C

Bateriile monocomadă Hansgrohe pot fi utilizate cu boiler instant cu comandă termică sau hidraulică dacă presiunea apei de alimentare este de min. 0,15 MPa.

Dacă apar probleme cu boilerul instant sau dacă doriți un debit de apă mai mare, puteți să demontați unitatea Waterdimmer® (reductor de debit 5a), care se află în spatele suflătorului de aer.

Bateria monocomadă cu limitarea apei calde, pentru reglare vezi pag. 8.

Dacă conectați bateria la un boiler instant nu este necesară instalarea unui opritor de apă caldă.

Piese de schimb vezi pag. 5

1	Mâner	33091000
1.1	Dop filetat	94191000
2	capac	94192000
	capac auriu	94192990
3	Piuliță	94194000
4	Cartuș cpl.	92730000
5	Pulverizator aer cpl. (10)	13912000
	Pulverizator aer cpl. gold	94980990
	Pulverizator aer cpl. (6 l/min)	96788000
6	Manetă de tragere	92620000
	Manetă de tragere auriu optic	92620990
7	Sistem de fixare	96016000
8	Furtun de racordare	95001000
9	Furtun de racordare	97206000

Accesorii opționale

Set cheie montare X 58085000
(nu este inclus în pachetul livrat)

Română

Certificat de testare

	DVGW	P-IX	SVGW	ACS	NF	WRAS	KIWA
33001000	X	P-IX 8388/IA	X			X	X
33002XXX	X	P-IX 8388/IA	X		X		X
33006000	X	P-IX 8388/IA	X				X
33007000							
33008000	X	P-IX 8388/IA	X		X		X
33011000							
33200XXX	X	P-IX 8388/IA	X			X	X
33202XXX	X	P-IX 8388/IA	X		X		X
33208000	X	P-IX 8388/IA	X		X		X

Limitator pentru apă caldă: Temperatură apă caldă: 60 C, temperatură apă rece: 10 C, presiune de curgere: 0,3 MPa.

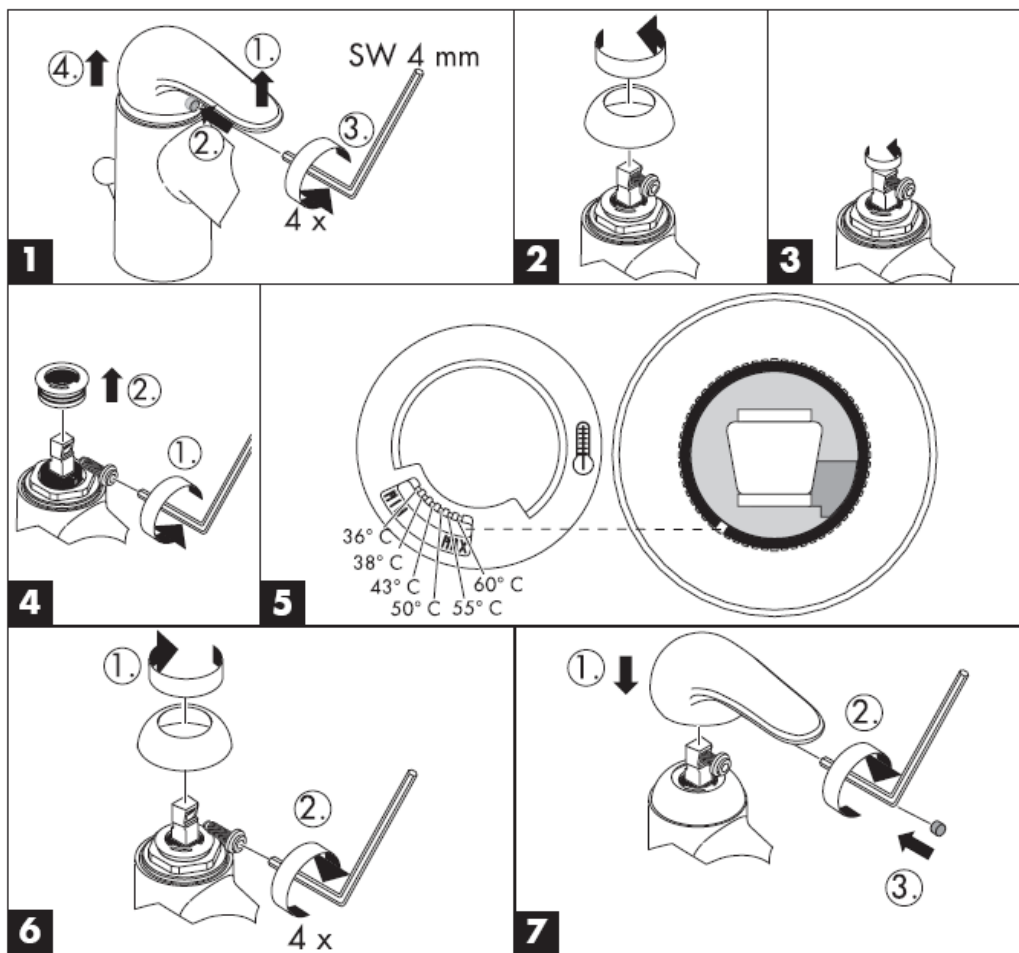

Curățare

Cu ajutorul sistemului Rubit® puteți să îndepărtați depunerile de calcar de pe diferitele duze de jet de apă prin frecare.



hansgrohe

Hansgrohe · Postfach 1145 · D-77761 Schiltach · Telefon +49 (0) 78 36/51-1282 · Telefax +49 (0) 7836/511440
E-Mail: info@hansgrohe.com · Internet: www.hansgrohe.com

05/2006
9.07956.04
Română

Οδηγία συναρμολόγησης



Talis E

33001000/33002XXX/33006000
33007000/33008000/33011000



Talis E

33200XXX/33202XXX/33208000

hansgrohe

33001000

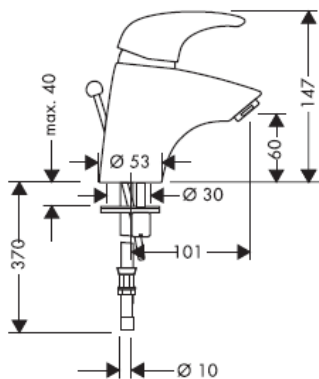

33200XXX

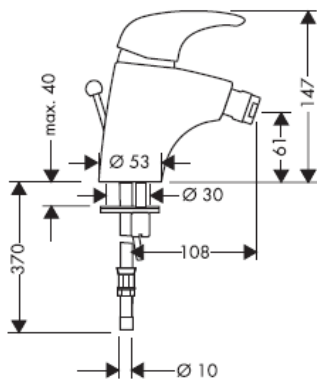

33002XXX

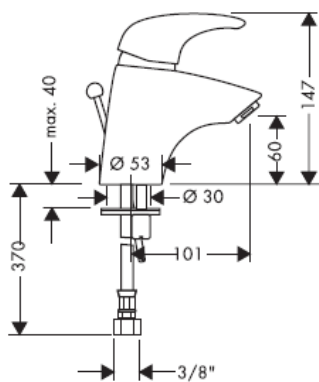

33202XXX

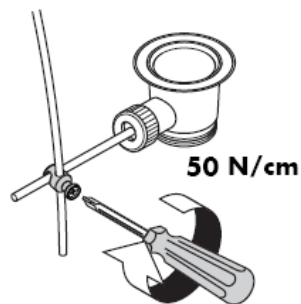
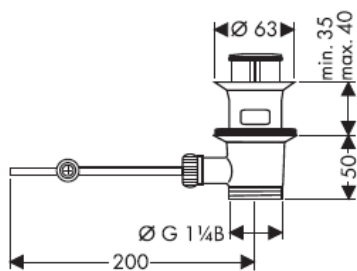
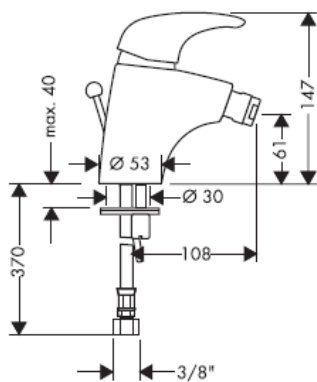

33008000

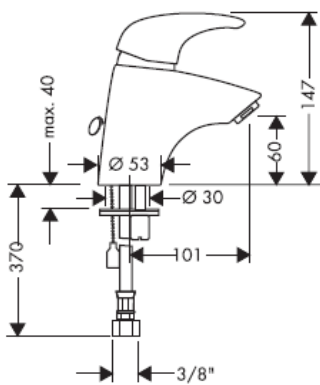

33208000

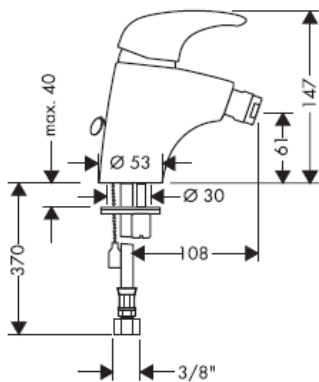

33006000

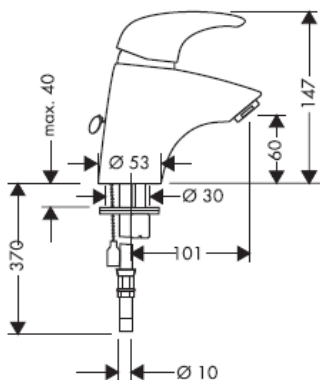

33007000

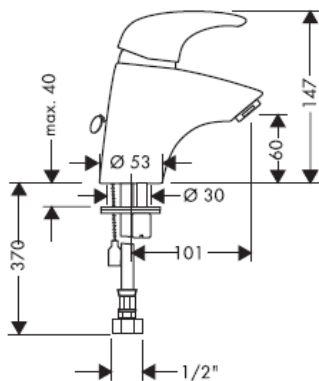

33011000

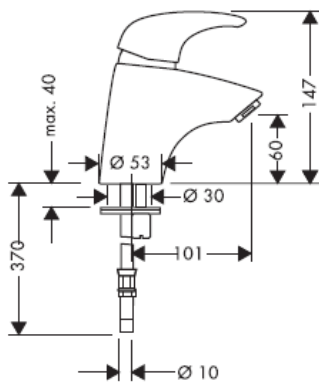

Συναρμολόγηση σωλήνα
σύνδεσης

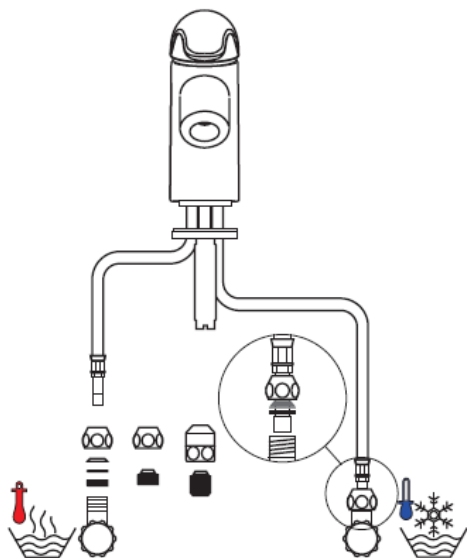
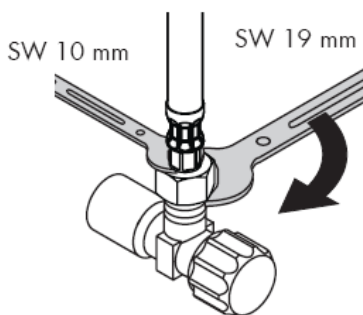
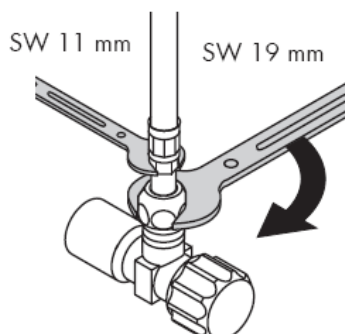
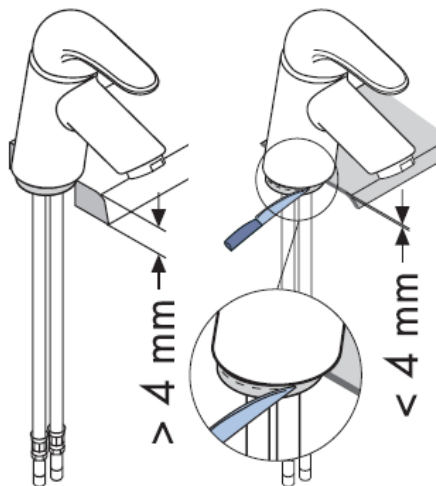
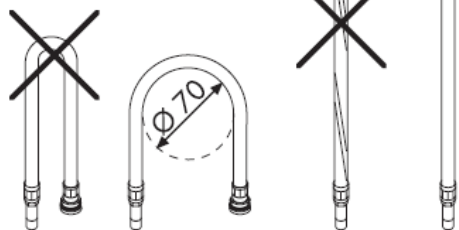

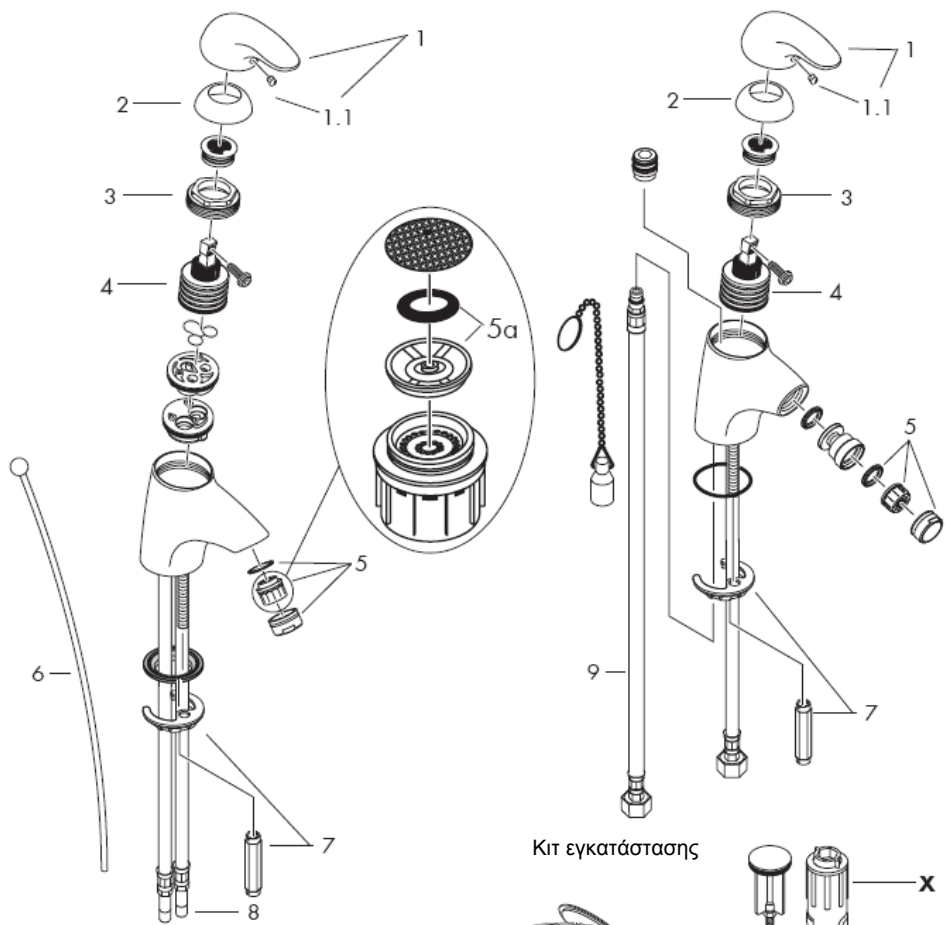

Κιτ εγκατάστασης

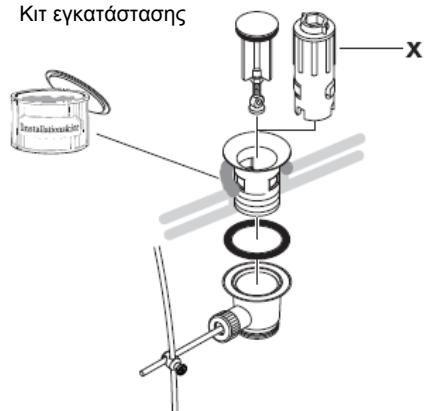

Προσοχή! Η κεντρική βάνα πρέπει να τοποθετηθεί, να πλυθεί και να ελεγχθεί με βάση τους ισχύοντες κανόνες υδραυλικής τέχνης!

Συναρμολόγηση

- 1 Πλένετε καλά τις σωληνώσεις σύνδεσης.
- 2 Τοποθετήστε την κεντρική βάνα με οπή στο νιππήρα / το μπινιτέ.
- 3 Περάστε τη ροδέλα στήριξης σωλήνα και το δίσκο στερέωσης μέσω των σωλήνων σύνδεσης και τους βιδωτούς αξονίσκους και σφίξτε γερά με το παξιμάδι.
- 4 Συνδέστε τους εύκαμπτους σωλήνες παροχής με τις γωνιακές βαλβίδες, κρύο δεξιά - ζεστό αριστερά.
- 5 33001000/32002XXX/33200XXX/
33202XXX: Συνδέετε τη ράβδο έλξης με τη βαλβίδα εκροής.

Οι διαφορές της πίεσης μεταξύ της σύνδεσης κρύου και ζεστού νερού θα πρέπει να αντισταθμίζονται.

Χειρισμός

Η μπαταρία λειτουργεί σηκώνοντας την κεντρική λαβή.

Γυρνώντας στα αριστερά = ζεστό νερό,
Γυρνώντας στα δεξιά = κρύο νερό.

Τεχνικά Χαρακτηριστικά

Τυποποιημένη κεντρική βάνα με ελαχιστοποιητή νερού (Waterdimmer®) (περιοριστική διάταξη νερού)

Κατανάλωση νερού με ελαχιστοποιητή νερού:
7 l/min 0,3 MPa
Κατανάλωση νερού χωρίς ελαχιστοποιητή νερού:
12 l/min 0,3 MPa
Λειτουργία πίεσης: max. 1 MPa
Συνιστώμενη λειτουργία πίεσης: 0,1 – 0,5 MPa
Πίεση ελέγχου: 1,6 MPa
(1 MPa = 10 bar = 147 PSI)
Συνιστώμενη θερμοκρασία ζεστού νερού: max 80° C
Συνιστώμενη θερμοκρασία ζεστού νερού: 60° C

Οι αναμεικτικές μπαταρίες Hansgrohe μπορούν να λειτουργούν και σε συνδυασμό με ταχυθερμοσίφωνα θερμικού ή υδραυλικού ελέγχου, εφόσον η ελάχιστη πίεση ροής είναι 0,15 MPa.

Εάν παρουσιαστεί πρόβλημα με τον ταχυθερμοσίφωνα ή όταν απαιτείται περισσότερο νερό, μπορεί να απομακρυνθεί ο ελαχιστοποιητής νερού (Waterdimmer®), (μειωτής ροής 5a), ο οποίος βρίσκεται πίσω από το φίλτρο.

Για να προσαρμόσετε το δοσομετρητή ζεστού νερού σε αναμεικτικές μπαταρίες, παρακαλούμε δείτε τη ρύθμιση στη σελ. 8.

Δεν είναι απαραίτητη η διάταξη φραγής ζεστού νερού σε συνδυασμό με ταχυθερμοσίφωνα.

Ανταλλακτικά βλ. Σελίδα 5

1	Λαβή	33091000
1.1	πώμα λαβής	94191000
2	Καλύπτρα	94192000
	Καλύπτρα επιχρυσωμένη	94192990
3	Παξιμάδι	94194000
4	Φυσίγγιο, πλήρες	92730000
5	Φίλτρο, πλήρες (10)	13912000
	Φίλτρο, πλήρες gold	94980990
	Φίλτρο, πλήρες (6 l/min)	96788000
6	Ράβδος έλξης	92620000
	Ράβδος έλξης οπτική χρυσού	92620990
7	Σταθεροποίηση κορμού, πλήρης	96016000
8	Εύκαμπτος σωλήνας παροχής	95001000
9	Εύκαμπτος σωλήνας παροχής	97206000

Ειδικά αξεσουάρ

X Σετ κλειδιών συναρμολόγησης 58058000 (δεν περιλαμβάνονται στον παραδοτέο εξοπλισμό)

Ελληνικά

Σήμα ελέγχου

	DVGW	P-IX	SVGW	ACS	NF	WRAS	KIWA
33001000	X	P-IX 8388/IA	X			X	X
33002XXX	X	P-IX 8388/IA	X		X		X
33006000	X	P-IX 8388/IA	X				X
33007000							
33008000	X	P-IX 8388/IA	X		X		X
33011000							
33200XXX	X	P-IX 8388/IA	X			X	X
33202XXX	X	P-IX 8388/IA	X		X		X
33208000	X	P-IX 8388/IA	X		X		X

Διάταξη περιορισμού ζεστού νερού: θερμοκρασία ζεστού νερού 60 °C, θερμοκρασία κρύου νερού 10 °C, πίεση ροής 0,3 MPa.

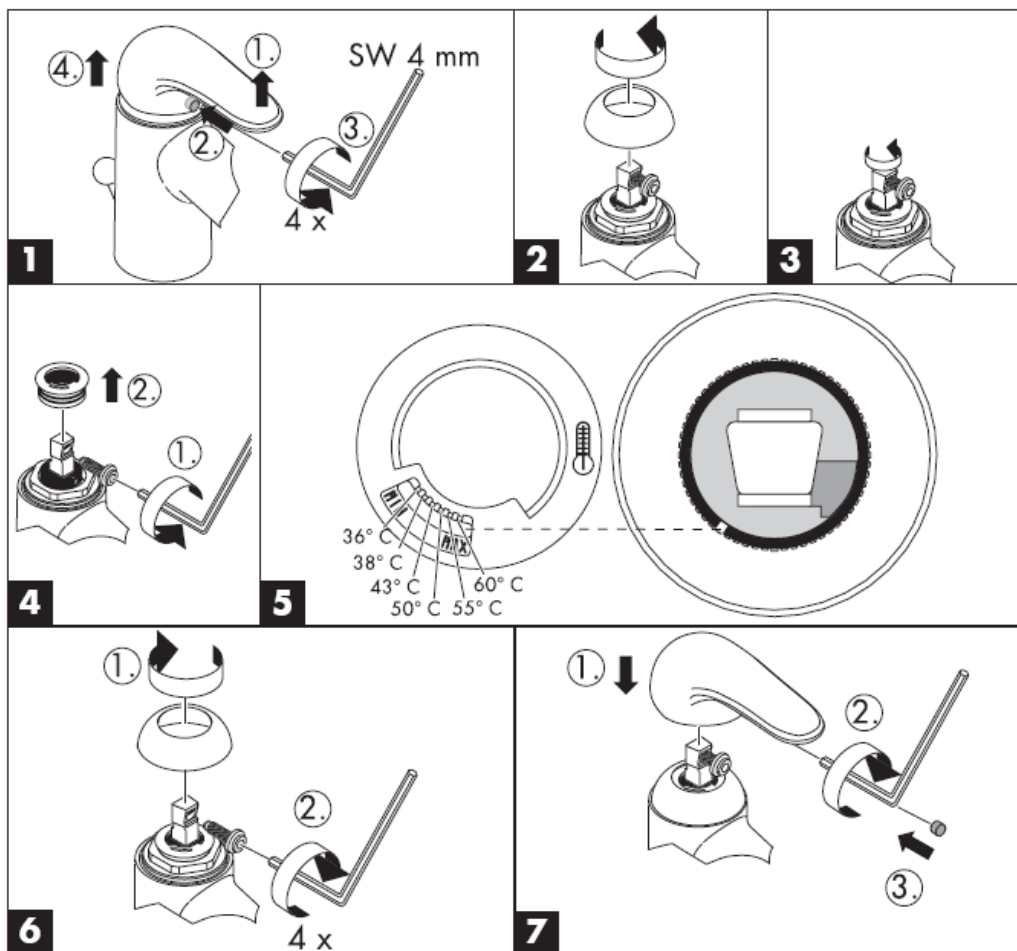

Καθαρισμός

Με Rubit®, τη λειτουργία καθαρισμού με το χέρι, μπορούν να απομακρυνθούν με απλό τρίψιμο τα άλατα από τα κανάλια του καταιονιστήρα.



hansgrohe

Hansgrohe · Postfach 1145 · D-77761 Schiltach · Telefon +49 (0) 78 36/51-1282 · Telefax +49 (0) 7836/511440
E-Mail: info@hansgrohe.com · Internet: www.hansgrohe.com

05/2006
9.07956.04
Ελληνικά

تعليمات التجميع



Talis E

33001000/33002XXX/33006000
33007000/33008000/33011000



Talis E

33200XXX/33202XXX/32208000

hansgrohe

33001000

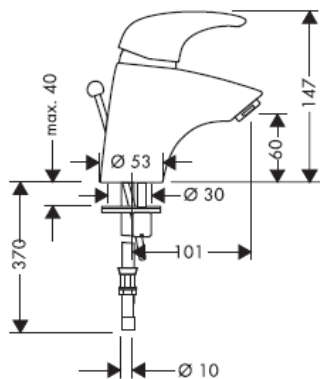

33200XXX

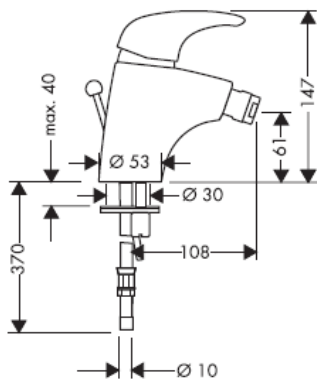

33002XXX

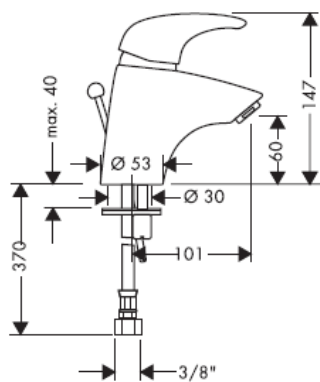

33202XXX

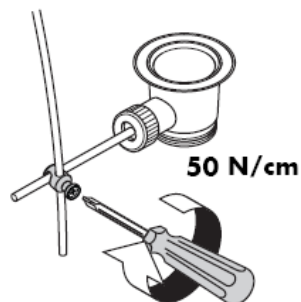
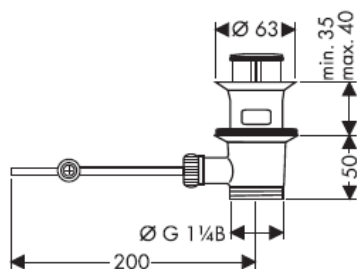
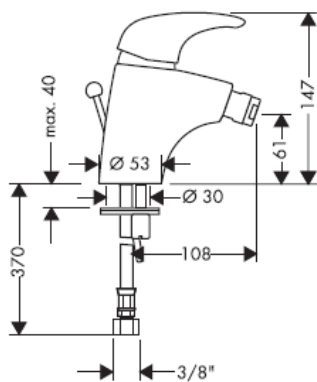

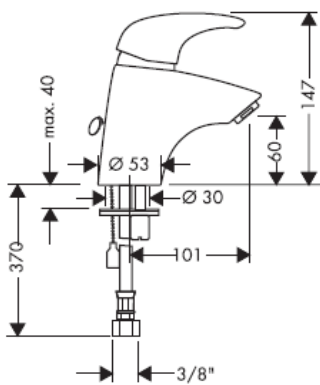
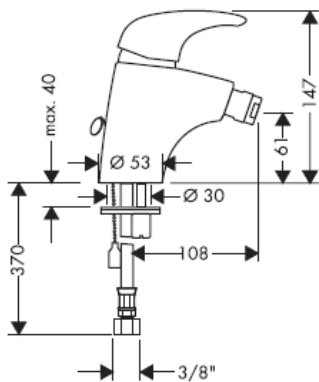
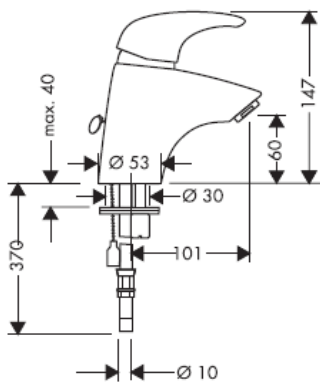
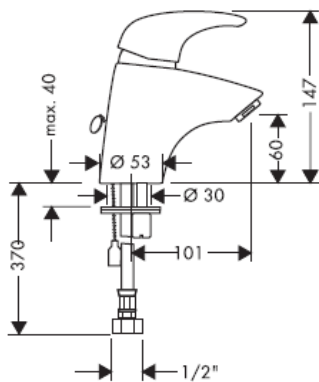
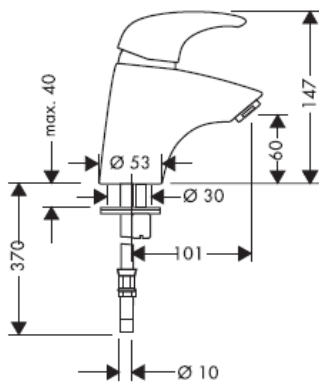
33008000**33208000****33006000****33007000****33011000**

تجميع خرطوم التوصيل

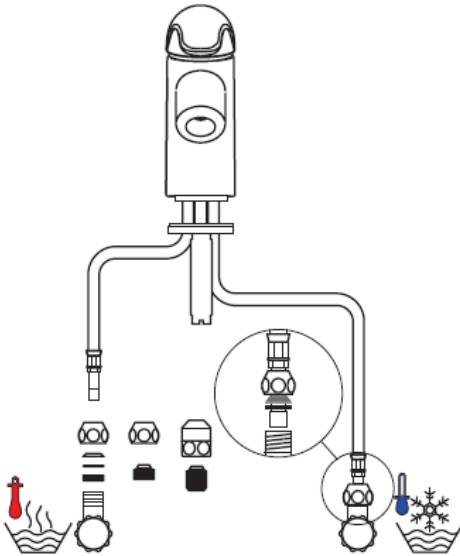
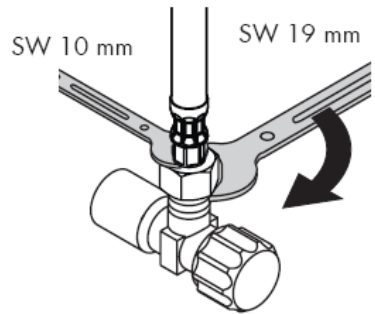
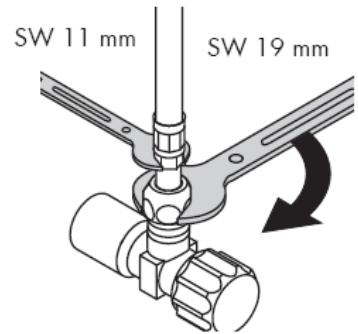
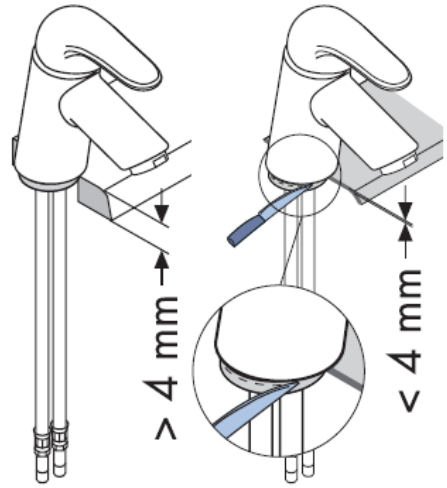
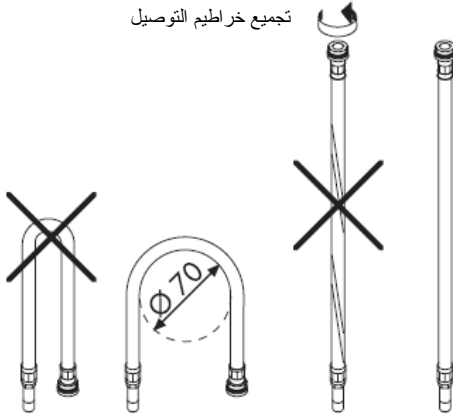

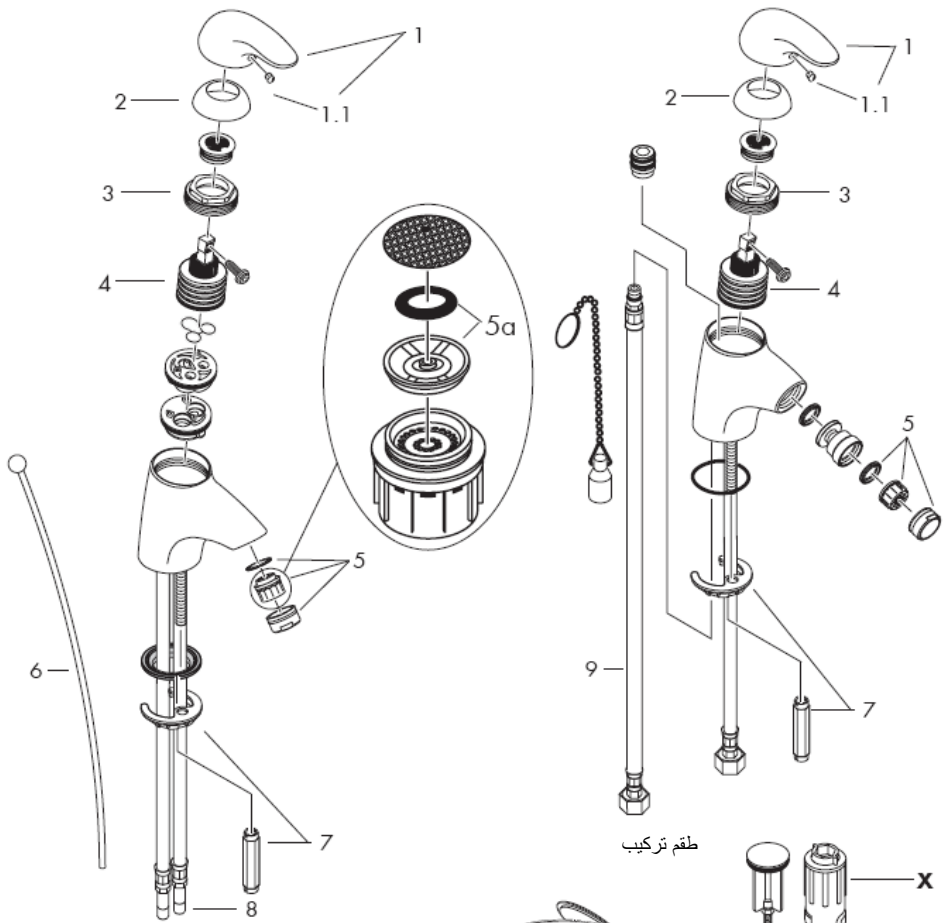

طاقم تركيب

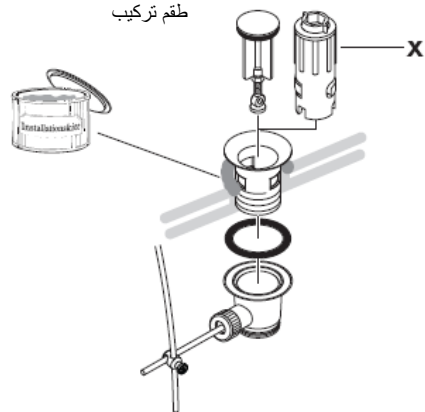

تنبيه! يجب تركيب الوصلة، وغمرها بالماء واختبارها وفقاً للمعايير السارية!

التركيب

يمكن استخدام خلطات هانزجرهه أحادية المقيض مع سخانات تدفق الماء ذات التحكم الهيدروليكي أو الحراري، مع ضغط تدفق لا يقل عن 1.5 بار.

إذا تجاوز ضغط الماء 5 بار، قم بتركيب صمام خافض للضغط. إذا تسبب سخان الماء المستمر في أية مشكلات أو في حال عدم وجود تدفق كافٍ للماء، يجب فك محدد تدفق المياه (® waterdimmer 5a) الموجود خلف تجهيزة التهوية.

لضبط محدد الماء الساخن في الخلطات ذات الرافعة الأحادية، يرجى الرجوع إلى صفحة 8. ولا يلزم إجراء أي ضبط عند استخدام سخان مياه ذي تدفق مستمر.

قطع الغيار راجع صفحة 5

33091000	1	مقيض
94191000	1.1	غطاء ملولب
94192000	2	فلانشة (شفة)
94192990		غطاء ذهبي
94194000	3	صمولة
92730000	4	خرطوشة
13912000	5	تجهيزة تهوية(10)
94980990		تجهيزة تهويةgold
96788000		تجهيزة تهوية(6 l/min)
92620000	6	قضيب السحب
92620990		قضيب السحب لون ذهبي
96016000	7	طقم التثبيت
95001000	8	خرطوم التوصيل
97206000	9	خرطوم التوصيل

ملحقات خاصة

طقم أدوات خاصة على شكل حرف X 58085000
(يتم طلبها كجزء إضافي)

- 1 قم بدفع المياه خلال مواسير الإمداد.
- 2 ضع الخلاط وحلقة منع التسرب في موضعهما بحوض الغسيل / البيديه.
- 3 قم بتحريك قطعة التثبيت مع وضع الحلقات على المسامير الملولة، ثم قم بربط الصواميل.
- 4 قم بتوصيل مواسير الإمداد بالصمامات الجانبية؛ الماء البارد جهة اليمين - الماء الساخن جهة اليسار.
- 5 33001000/32002XXX/33200XXX/
333202XXX: قم بتوصيل قضيب السحب بامسورة الصرف.

يجب أن يكون تيار الماء الساخن والماء البارد متعادلين في الضغط.

التشغيل

يتم تنشيط الخلاط من خلال رفع مقيض الرافعة. التدوير إلى اليسار = ماء أكثر سخونة، والتدوير إلى اليمين = ماء أكثر برودة.

المواصفات الفنية

تم إنتاج هذه الخلاط في سلسلة واحدة مع ®waterdimmer (محدد تدفق المياه).

معدل تدفق المياه باستخدام مخفف المياه: 7 لتر / الدقيقة عند ضغط 3 بار

7 l/min 0,3 MPa

معدل تدفق المياه بدون استخدام مخفف المياه: 14 لتر / دقيقة عند ضغط 3 بار

12 l/min 0,3 MPa

max. 1 MPa

0,1 – 0,5 MPa

1,6 MPa

ضغط التشغيل:

ضغط التشغيل الموصى به:

ضغط الاختبار:

(1 MPa = 147 PSI = 10 بار)

max 80° C

60° C

درجة الحرارة الموصى بها للماء الساخن:

درجة الحرارة الموصى بها للماء الساخن:

	DVGW	P-IX	SVGW	ACS	NF	WRAS	KIWA
33001000	X	P-IX 8388/IA	X			X	X
33002XXX	X	P-IX 8388/IA	X		X		X
33006000	X	P-IX 8388/IA	X				X
33007000							
33008000	X	P-IX 8388/IA	X		X		X
33011000							
33200XXX	X	P-IX 8388/IA	X			X	X
33202XXX	X	P-IX 8388/IA	X		X		X
33208000	X	P-IX 8388/IA	X		X		X

محدد الماء الساخن: درجة حرارة الماء الساخن 60 مئوية، درجة حرارة الماء البارد تبلغ 10 مئوية، ضغط التدفق 3 بار.

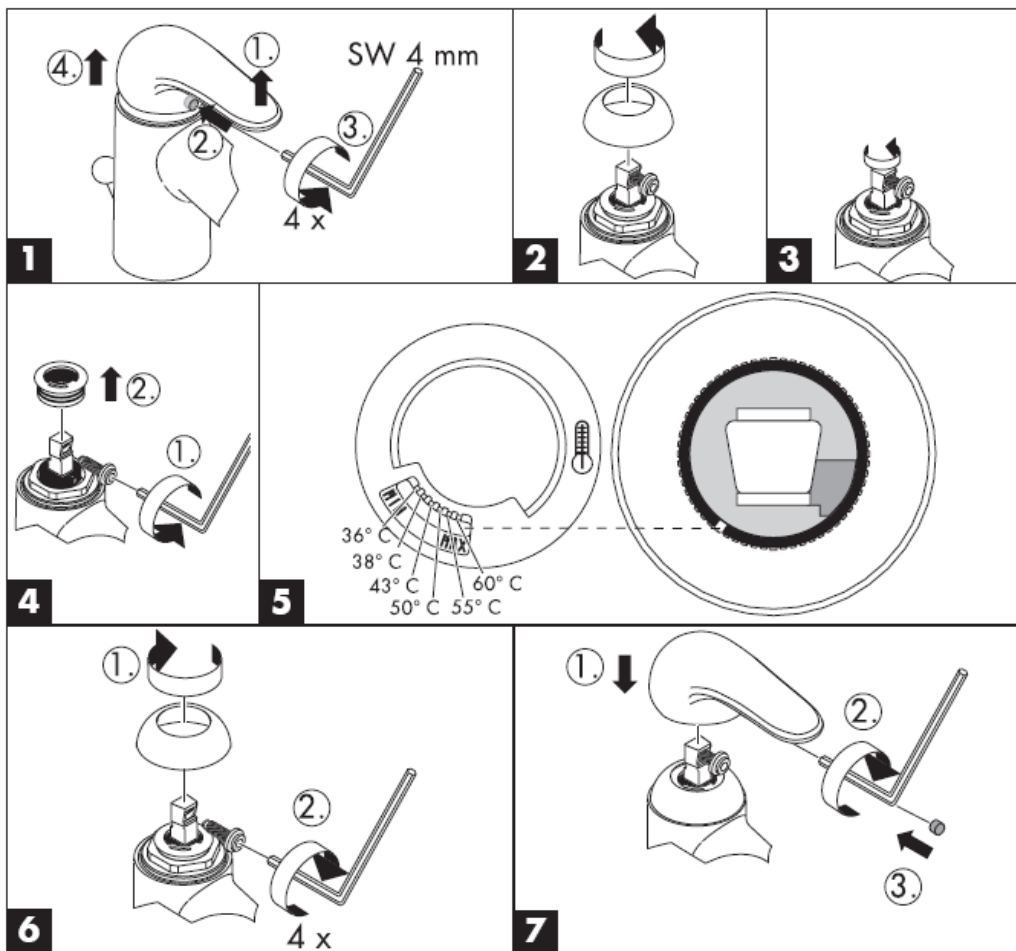

لا تحتاج وظيفة تنظيف سوى قدر بسيط من الفك باليد لإزالة القشور الجيرية من قنوات الرشاش.



Navodila za montažo



Talis E

33001000/33002XXX/33006000
33007000/33008000/33011000



Talis E

33200XXX/33202XXX/33208000

hansgrohe

33001000

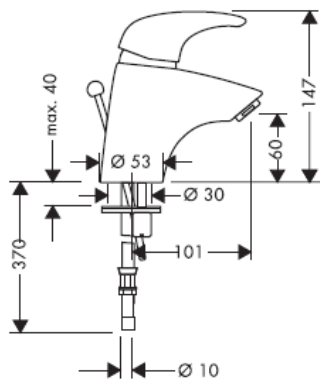

33200XXX

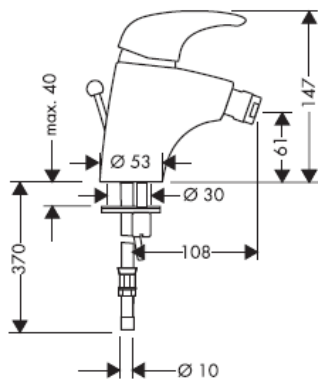

33002XXX

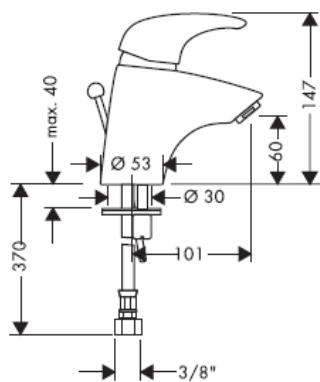

33202XXX

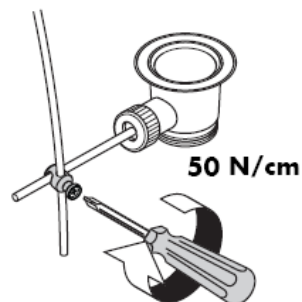
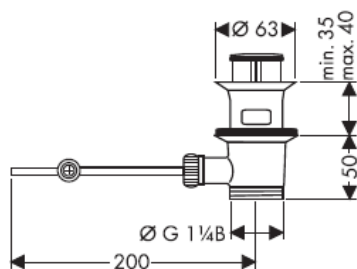
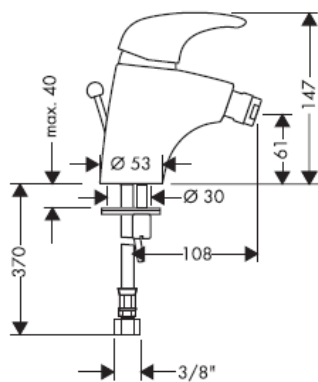

33008000

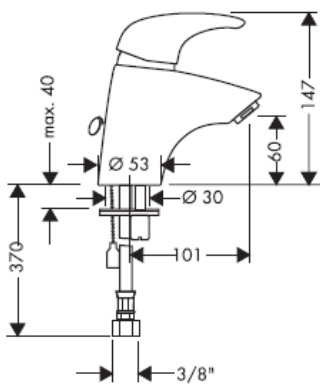

33208000

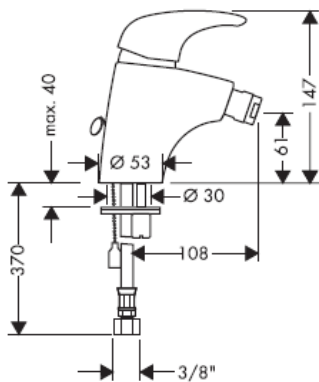

33006000

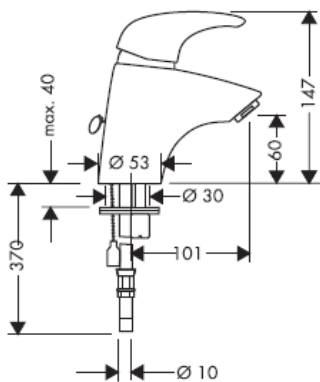

33007000

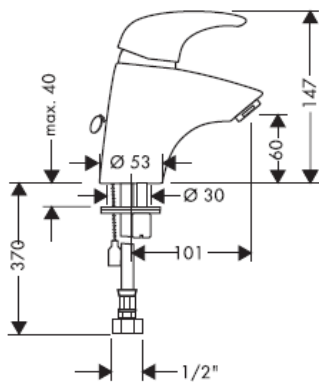

33011000

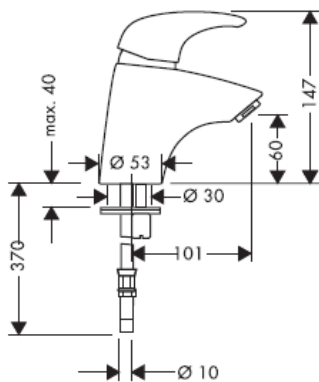

Montaža priključne gibke cevi

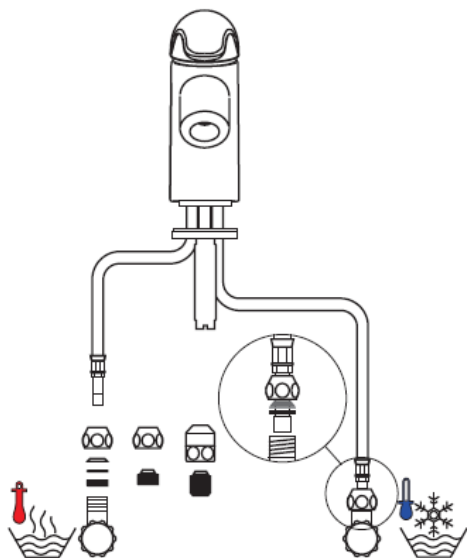
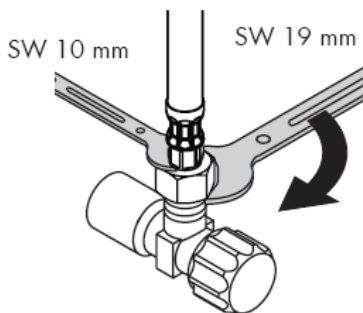
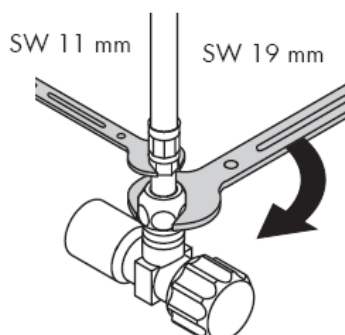
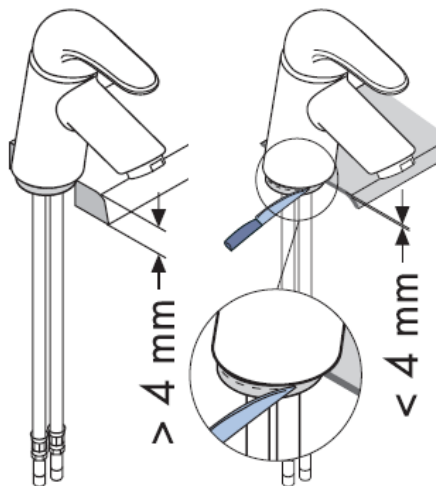
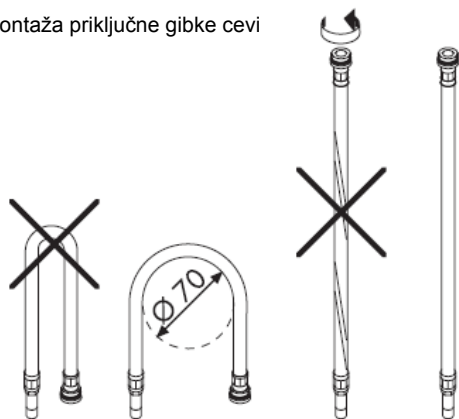

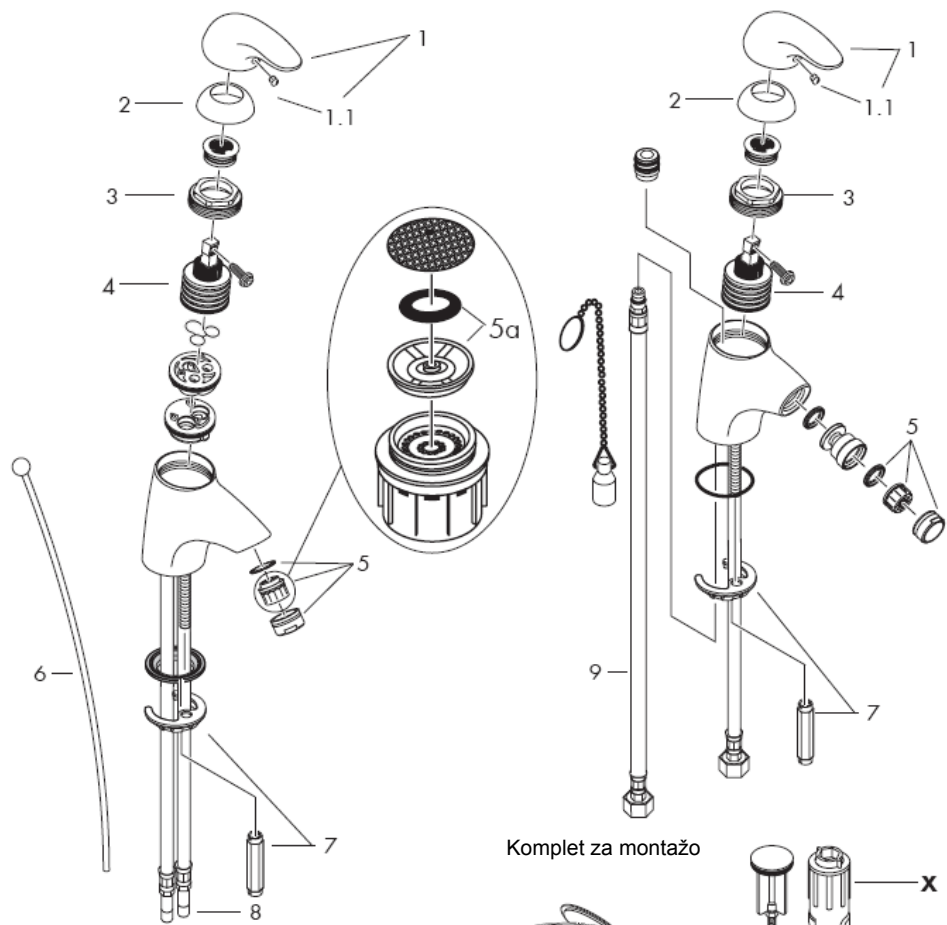

Komplet za montažo

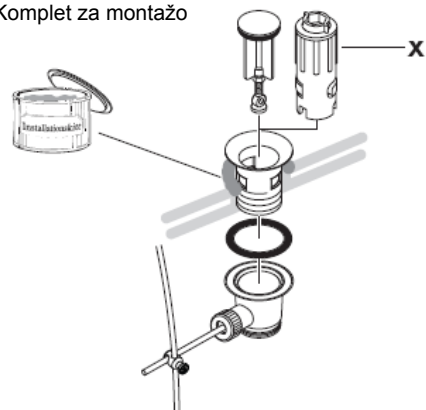

Pozor! La robinetterie doit être installée, rincée et contrôlée conformément aux normes valables!

Montaža

- 1 Strokovno izplaknite dovodne cevi.
- 2 Vstavite armaturo s tesnilnim obročkom v umivalnik/bide.
- 3 Potisnite podložko in pritrdilno ploščico prek priključnih cevi in navojnega nastavka in zatisnite z matico.
- 4 Priključite dovodne cevi na kotne ventile, mrzla desno - topla levo.
- 5 33001000/32002XXX/33200XXX/
33202XXX: Povežite vlečni drog z odtočnim ventilom.

Velike razlike v tlaku med priključkom za mrzlo in priključkom za toplo vodo je potrebno izravnati.

Upravljanje

Z dvigom ročke mešalno baterijo odprete. Zasak v levo = topla voda, zasak v desno = mrzla voda.

Tehnični podatki

Ta serija armatur je opremljena z waterdimmerjem® (omejevalnikom pretoka vode)

Pretok vode z waterdimmerjem (omejevalnikom pretoka):

7 l/min 0,3 MPa

Pretok vode brez waterdimmerja (omejevalnika pretoka)

12 l/min 0,3 MPa

Delovni tlak: max. 1 MPa

Priporočeni delovni tlak: 0,1 – 0,5 MPa

Preskusni tlak: 1,6 MPa

(1 MPa = 10 bar = 147 PSI)

Priporočena temperatura tople vode: max 80° C

Priporočena temperatura tople vode: 60° C

Enoročne mešalne baterije Hansgrohe lahko uporabljate v povezavi s hidravlično in termično uravnanimi pretočnimi grelniki, če je pretočni tlak najmanj 0,15 MPa.

Če imate probleme s pretočnim grelnikom ali če želite večji pretok vode, lahko odstranite waterdimmer® (omejevalnik pretoka vode 5a), ki se nahaja za perlatorjem.

Enoročne mešalne baterije z omejevalnikom tople vode, za justiranje glejte stran 8. V povezavi s pretočnimi grelniki zapora tople vode ni potrebna.

Rezervni deli glejte stran 5

1	Ročka	33091000
1.1	Pokrov/čep	94191000
2	Prirobnica	94192000
	Prirobnica zlata	94192990
3	Matica	94194000
4	Vložek	92730000
5	Perlator kpl. (10)	13912000
	Perlator kpl. gold	94980990
	Perlator kpl. (6 l/min)	96788000
6	Vlečni drog	92620000
	Vlečni drog pozlačena	92620990
7	Pritrdilni	96016000
8	Priključna gibka cev	95001000
9	Priključna gibka cev	97206000

Poseben pribor

X komplet ključev za montažo 58085000 (potrebno naročiti posebej)

Slovenski

Preskusni znak

	DVGW	P-IX	SVGW	ACS	NF	WRAS	KIWA
33001000	X	P-IX 8388/IA	X			X	X
33002XXX	X	P-IX 8388/IA	X		X		X
33006000	X	P-IX 8388/IA	X				X
33007000							
33008000	X	P-IX 8388/IA	X		X		X
33011000							
33200XXX	X	P-IX 8388/IA	X			X	X
33202XXX	X	P-IX 8388/IA	X		X		X
33208000	X	P-IX 8388/IA	X		X		X

Omejitev tople vode: temperatura tople vode 60 C, temperatura mrzle vode 10 C, pretočni tlak 0,3 MPa.

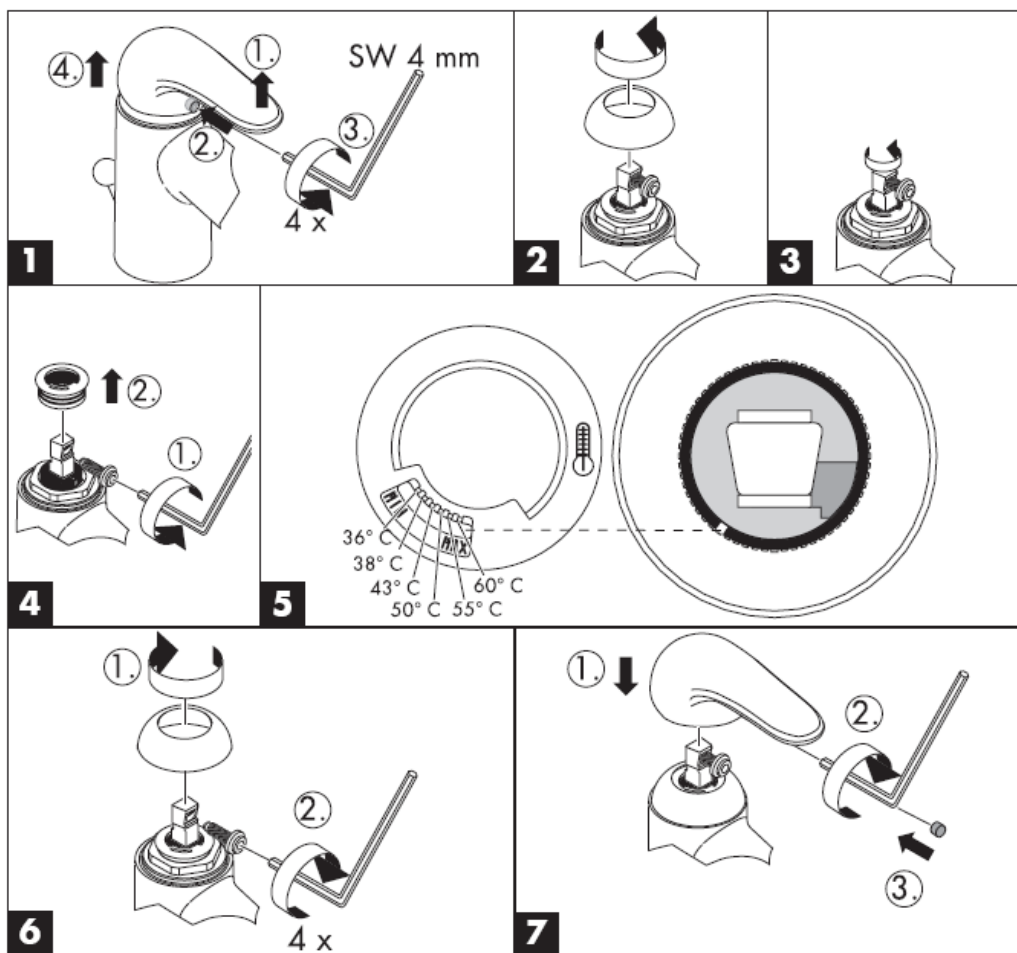

Čiščenje

Z Rubit®, ročno čistilno funkcijo, lahko s šob očistimo vodni kamen tako, da šobe enostavno podrgnemo.



hansgrohe

Hansgrohe · Postfach 1145 · D-77761 Schiltach · Telefon +49 (0) 78 36/51-1282 · Telefax +49 (0) 7836/511440
E-Mail: info@hansgrohe.com · Internet: www.hansgrohe.com

05/2006
9.07956.04
Slovenski

Paigaldusjuhend



Talis E

33001000/33002XXX/33006000
33007000/33008000/33011000



Talis E

33200XXX/33202XXX/32208000

hansgrohe

33001000

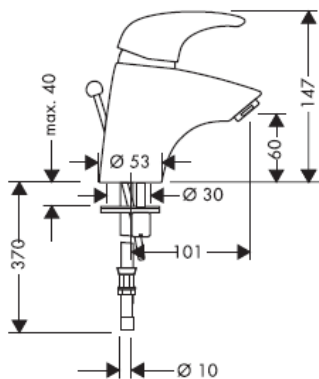

33200XXX

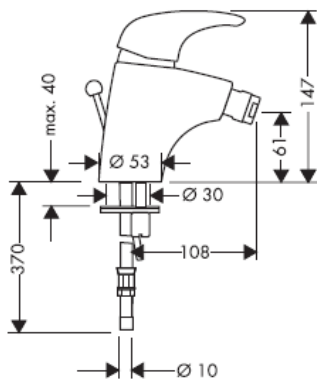

33002XXX

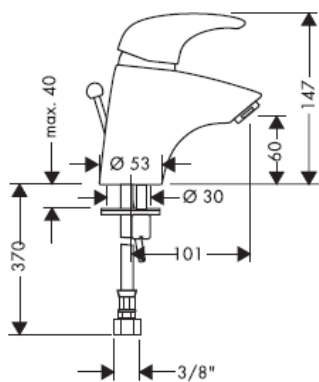

33202XXX

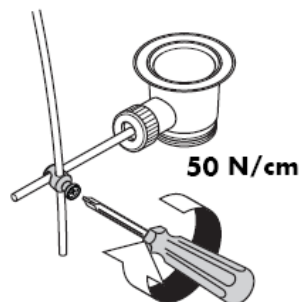
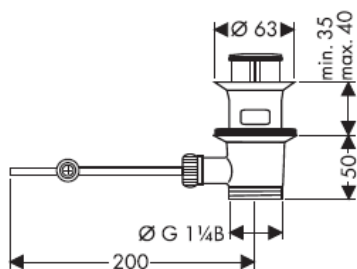
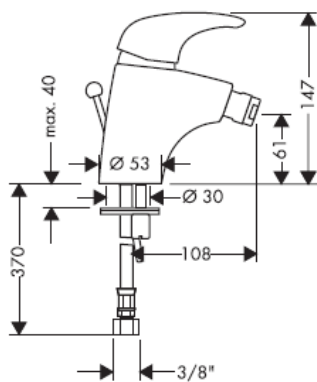

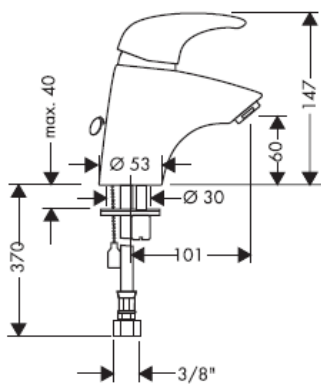
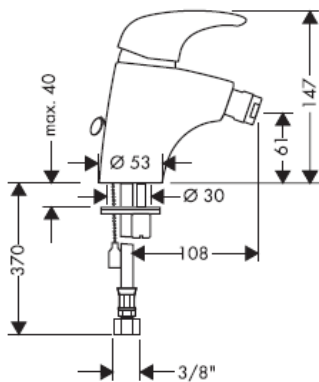
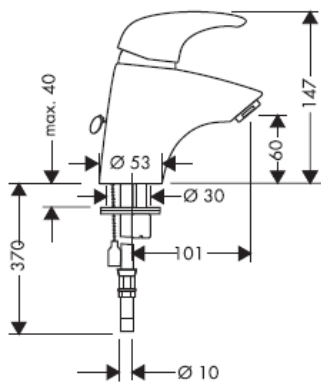
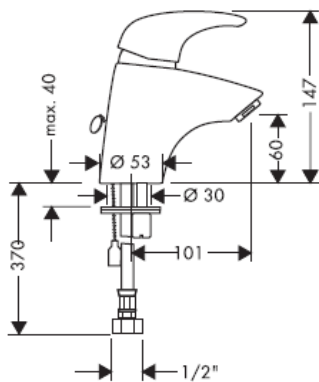
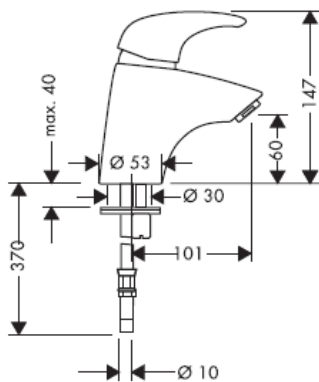
33008000**33208000****33006000****33007000****33011000**

Ühendusvooliku paigaldamine

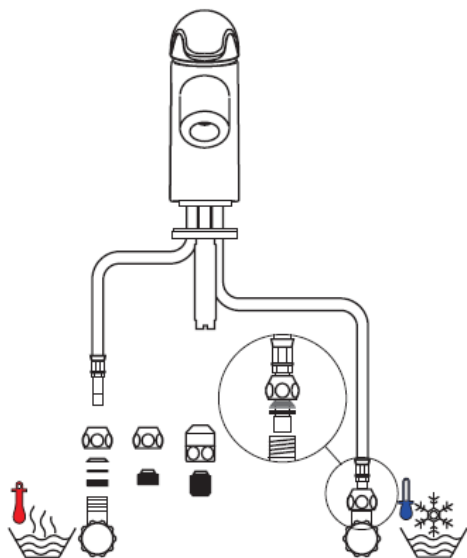
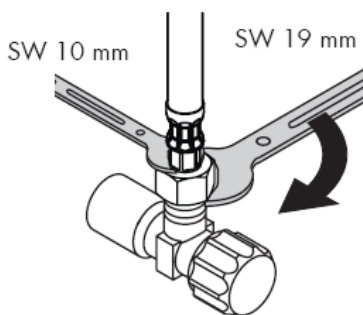
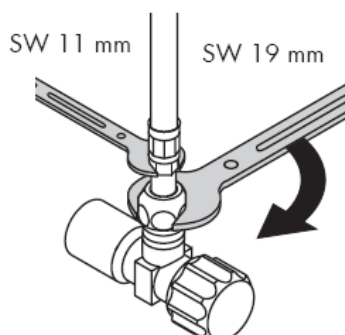
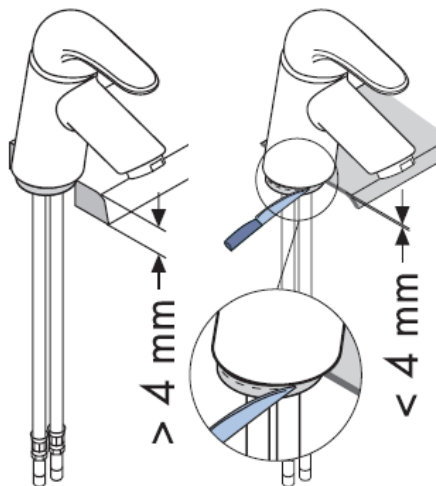
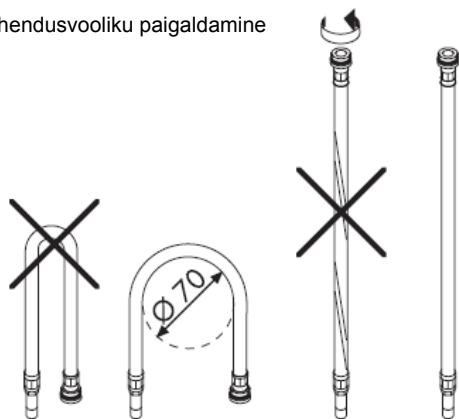

Tähelepanu! Segisti paigaldamine, loputamine ja kontroll peab toimuma vastavalt kehtivatele normidele!

Paigaldamine

- 1 Peske etteandetorud läbi.
- 2 Asetage segisti koos vahetihendiga valamule/bideele.
- 3 Lükake alusseib ja kinnitusseib üle ühendustorude ja keermetihvti ning kinnitage mutriga.
- 4 Ühendage ühendusvoolikud veevarustuse nurgaklappidega, külm paremale, kuum vasakule.
- 5 33001000/32002XXX/33200XXX/33202XXX: Ühendage tõmbekang äravooluklapiga.

Kui külma ja kuuma vee ühenduste surve on väga erinev, tuleb need tasakaalustada.

Kasutamine

Segisti avaneb kangi ülestõstmisel. Vasakule pöörates = kuum vesi, paremale pöörates = külm vesi.

Tehnilised andmed

Segistisari on toodetud koos Waterdimmer® veehulgapiirajaga

Läbivool Waterdimmer'i korral:

7 l/min 0,3 MPa

Läbivool ilma Waterdimmer'ita:

12 l/min 0,3 MPa

Töörõhk max. 1 MPa

Soovitav töörõhk: 0,1 – 0,5 MPa

Kontrollsurve: 1,6 MPa

(1 MPa = 10 baari = 147 PSI)

Soovitav kuuma vee temperatuur: max 80° C

Soovitav kuuma vee temperatuur: 60° C

Hansgrohe ühekäe segisteid võib kasutada koos hüdrauliselt ja termiliselt juhitavate boileritega, kui vee rõhk on vähemalt 0,15 MPa.

Kui esineb probleeme läbivooluhooleiga või kui soovitakse, et vee läbivool oleks suurem, tuleks sõela taga asuv Waterdimmer® (veehulgapiiraja 5a) eemaldada.

Ühe juhtkangiga segisti kuuma vee piiraja reguleerimise kohta vt lk 8. Läbivoolu boilerite puhul pole reguleerimine vajalik.

Varuosad vt lk 5

1	käepide	33091000
1.1	käepideme kaas	94191000
2	äärrik	94192000
	äärrik, kuldne	94192990
3	mutter	94194000
4	tööelement	92730000
5	õhustaja kpl (10)	13912000
	õhustaja kpl gold	94980990
	õhustaja kpl (6 l/min)	96788000
6	tõmbekang	92620000
	tõmbekang kuld optik	92620990
7	kinnituskomplekt	96016000
8	ühendusvoolik	95001000
9	ühendusvoolik	97206000

Spetsiaalne lisavarustus

X montaaživõtmete komplekt 58085000 (eritellimusel)

Estonia

Kontrollsertifikaat

	DVGW	P-IX	SVGW	ACS	NF	WRAS	KIWA
33001000	X	P-IX 8388/IA	X			X	X
33002XXX	X	P-IX 8388/IA	X		X		X
33006000	X	P-IX 8388/IA	X				X
33007000							
33008000	X	P-IX 8388/IA	X		X		X
33011000							
33200XXX	X	P-IX 8388/IA	X			X	X
33202XXX	X	P-IX 8388/IA	X		X		X
33208000	X	P-IX 8388/IA	X		X		X

Kuuma vee piiraja: kuum vesi 60 C, külm vesi 10 C, rõhk 0,3 MPa.

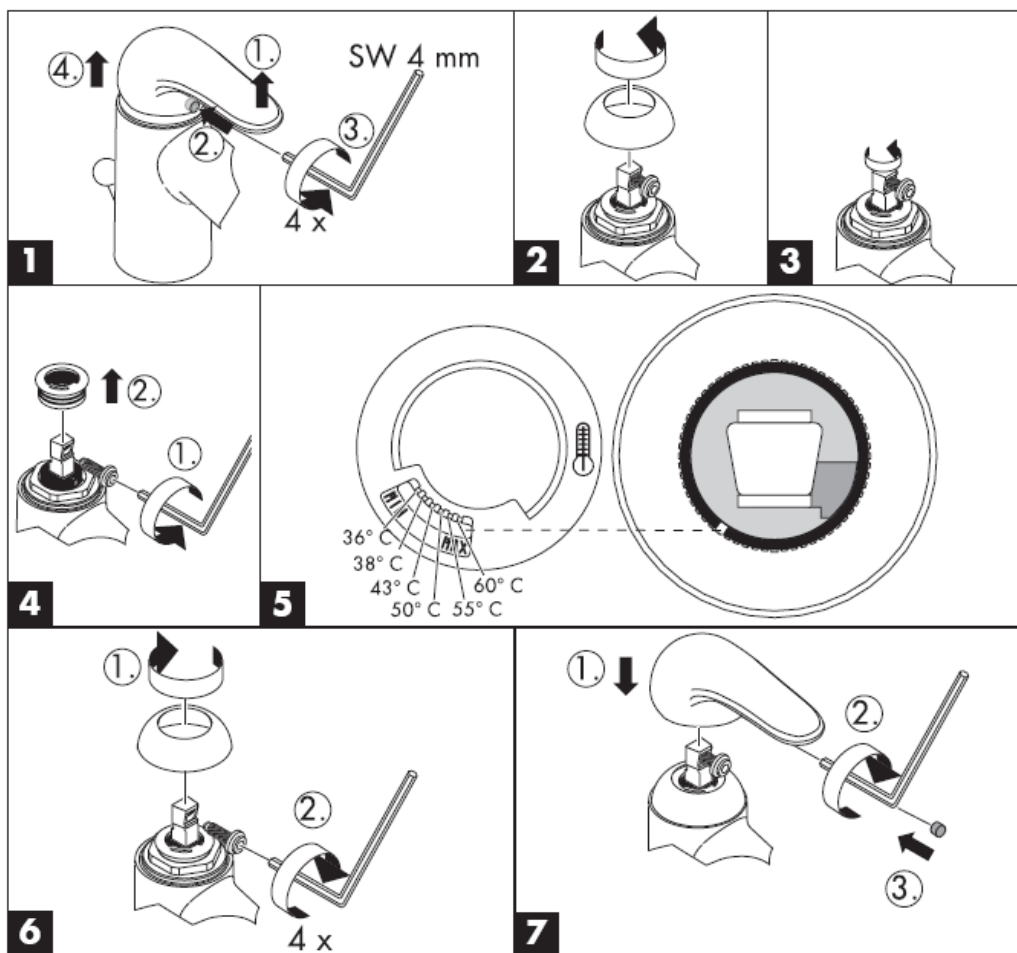

Puhastamine

Käsitsi puhastamise funktsiooni Rubit® puhul on vajalik vaid kerge ülehõõrumine, eemaldamaks dušikanalitest katlakivi.



hansgrohe

Hansgrohe · Postfach 1145 · D-77761 Schiltach · Telefon +49 (0) 78 36/51-1282 · Telefax +49 (0) 7836/511440
E-Mail: info@hansgrohe.com · Internet: www.hansgrohe.com

05/2006
9.07956.04
Estonia

Montāžas instrukcija



Talis E

33001000/33002XXX/33006000
33007000/33008000/33011000



Talis E

33200XXX/33202XXX/33208000

hansgrohe

33001000

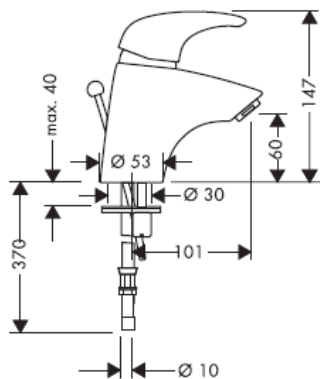

33200XXX

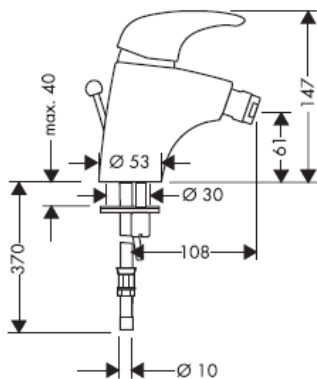

33002XXX

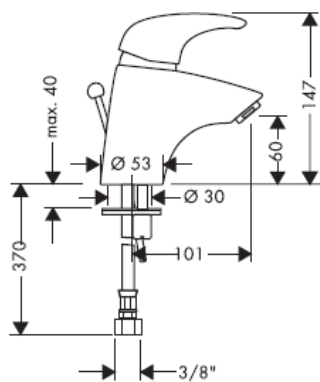

33202XXX

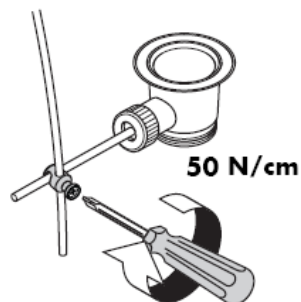
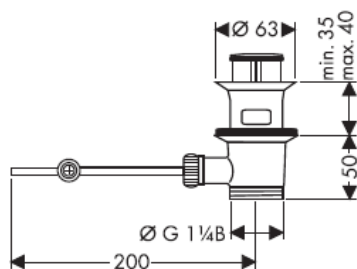
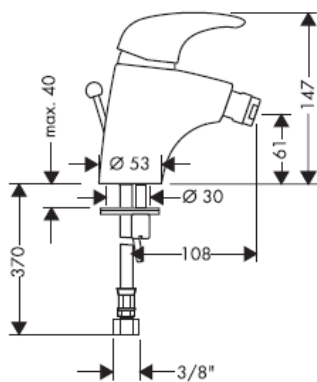

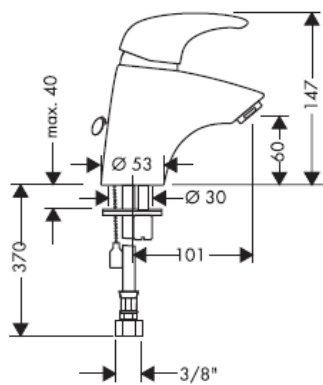
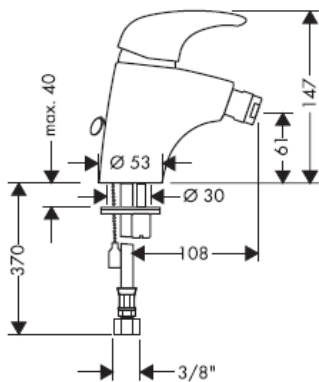
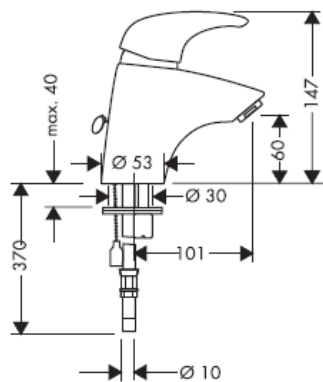
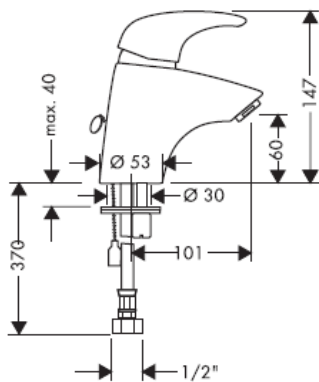
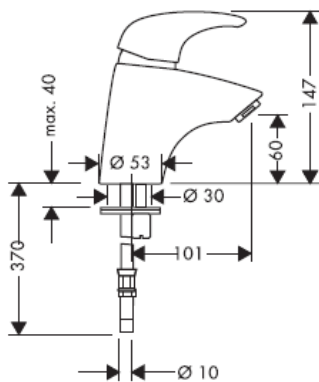
33008000**33208000****33006000****33007000****33011000**

Pieslēguma šļūtenes montāža

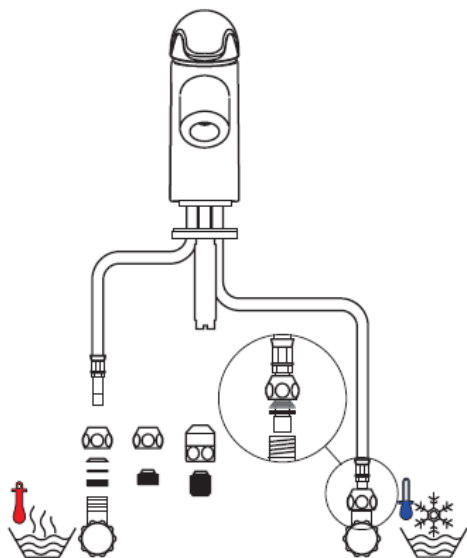
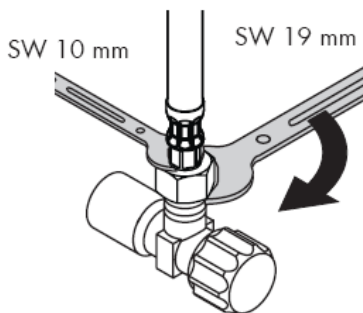
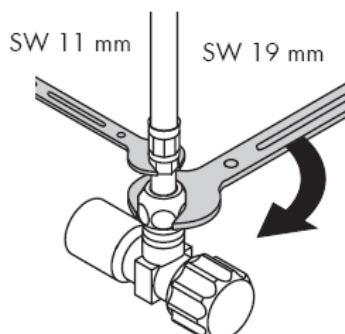
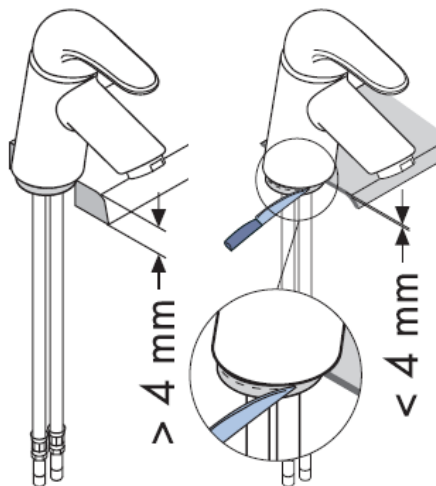
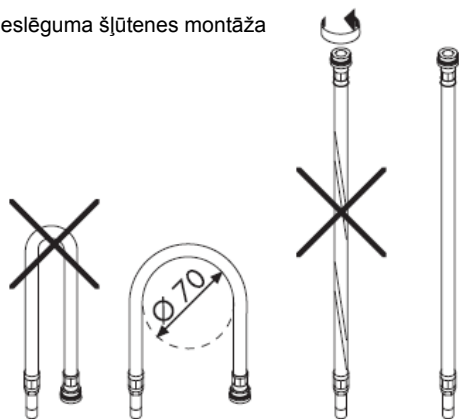

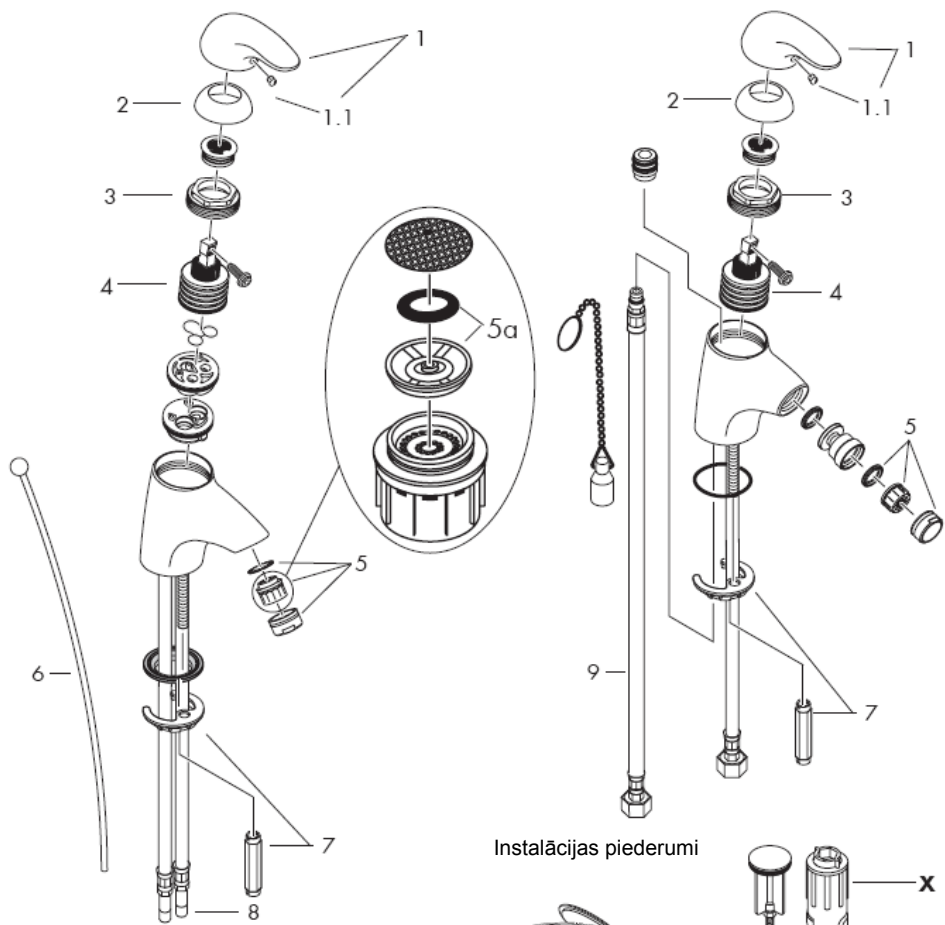

Instalācijas piederumi

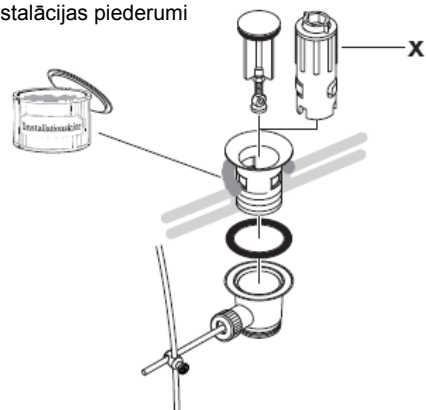

Uzmanību! Armatūra jāuzstāda, jāzskalo un jāpārbauda atbilstoši spēkā esošajām normām!

Montāža

- 1 Atbilstoši izskatot pievadus.
- 2 Jaucējkrānu ar blīvi iestiprina izlietnē / bidē.
- 3 Pāri savienotājcaurulei un vītnes tapām pārvelk paliekamo paplāksni un stiprinājuma plāksni un pievelk ar uzgriezni.
- 4 Pievienot pie stūra ventīļiem pieslēguma šļūtenes; auksto pa labi - karsto pa kreisi.
- 5 33001000/32002XXX/33200XXX/
33202XXX: Savienot izvelkamo stieni ar noplūdes vārstu.

Jāizlīdzina spiediena atšķirības starp aukstā un karstā ūdens pievadiem.

Lietošana

Paceļot rokturi, jaucējkrāns tiek atvērts. Pavirzot to pa kreisi = karstāks ūdens, pavirzot pa labi = aukstāks ūdens.

Tehniskie dati

Jaucējkrāns tiek ražots kopā ar

Waterdimmer® (caurteces ierobežotājs)

Caurteces intensitāte ar Waterdimmer:
7 l/min 0,3 MPa
Caurteces intensitāte bez Waterdimmer:

12 l/min 0,3 MPa

Darba spiediens:
max. 1 MPa
Ieteicamais darba spiediens: 0,1 – 0,5 MPa
Pārbaudes spiediens: 1,6 MPa
(1 MPa = 10 bar = 147 PSI)

Ieteicamā karstā ūdens temperatūra: max 80° C
Ieteicamā karstā ūdens temperatūra: 60° C

Hansgrohe viensvires jaucējkrānus var izmantot kombinācijā ar hidrauliski un termiski vadāmiem caurteces sildītājiem, ja plūsmas spiediens ir vismaz 0,15 MPa.

Ja rodas problēmas ar caurteces sildītāju vai arī ja nav pietiekama ūdens plūsma, jānoņem Waterdimmer® (caurteces ierobežotājs 5a), kur atrodas aiz aeratora.

Viensvires jaucējkrāns ar siltā ūdens ierobežošanu, ieregulēšanu skat. 8. lpp. Kombinācijā ar caurteces sildītāju karstā ūdens ierobežošana nav nepieciešama.

Rezerves daļas skat. lpp. 5

1	rokturis	33091000
1.1	dekoratīvs aizbāznis	94191000
2	vāciņš	94192000
	vāciņš zeltīts	94192990
3	uzgrieznis	94194000
4	Kartuša, kompl.	92730000
5	Aeratora kompl. (10)	13912000
	Aeratora kompl. gold	94980990
	Aeratora kompl. (6 l/min)	96788000
6	Izvelkamais stienis	92620000
	Izvelkamais stienis zelta	92620990
7	Stiprinājuma elementu	96016000
8	Pieslēguma šļūtene	95001000
9	Pieslēguma šļūtene	97206000

Speciāli aksesuāri

X montāžas atslēgu komplekts 58085000 (netiek piedāvāts komplektācijā)

Latviski

Pārbaudes zīme

	DVGW	P-IX	SVGW	ACS	NF	WRAS	KIWA
33001000	X	P-IX 8388/IA	X			X	X
33002XXX	X	P-IX 8388/IA	X		X		X
33006000	X	P-IX 8388/IA	X				X
33007000							
33008000	X	P-IX 8388/IA	X		X		X
33011000							
33200XXX	X	P-IX 8388/IA	X			X	X
33202XXX	X	P-IX 8388/IA	X		X		X
33208000	X	P-IX 8388/IA	X		X		X

Karstā ūdens ierobežotājs: karstā ūdens temperatūra 60 C, aukstā ūdens temperatūra 10 C, plūsmas spiediens 0,3 MPa.

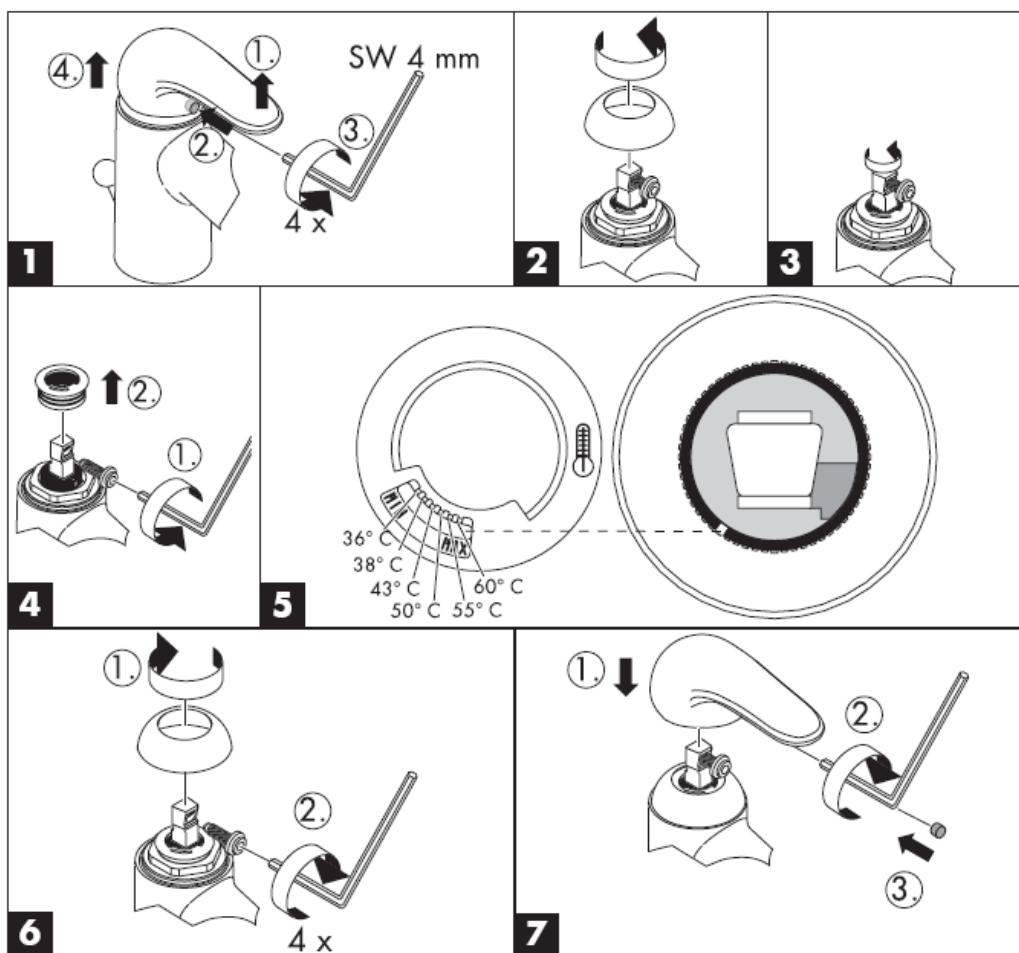

Tīrīšana

Rubit® attīrīšanas funkcija - strūklas kanāliņi vienkāršas manuālas berzes rezultātā tiek attīrīti no kaļķa.



hansgrohe

Hansgrohe · Postfach 1145 · D-77761 Schiltach · Telefon +49 (0) 78 36/51-1282 · Telefax +49 (0) 7836/511440
E-Mail: info@hansgrohe.com · Internet: www.hansgrohe.com

05/2006
9.07956.04
Latviski

Uputstvo za montažu



Talis E

33001000/33002XXX/33006000
33007000/33008000/33011000



Talis E

33200XXX/33202XXX/33208000

hansgrohe

33001000

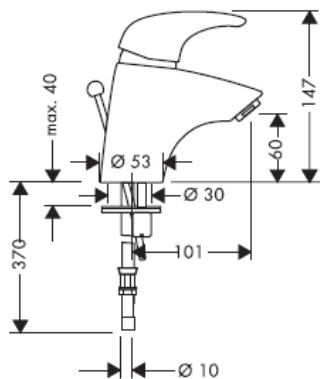

33200XXX

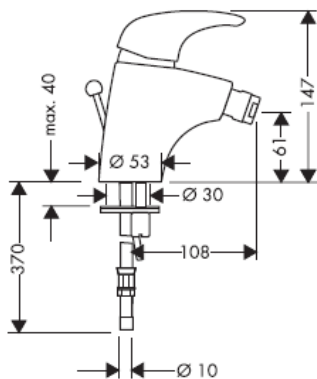

33002XXX

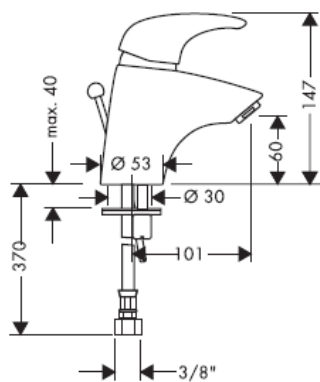

33202XXX

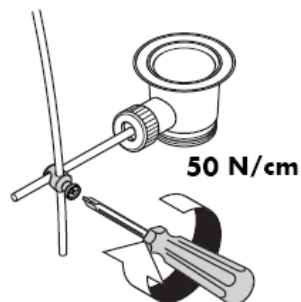
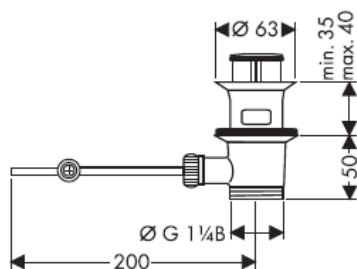
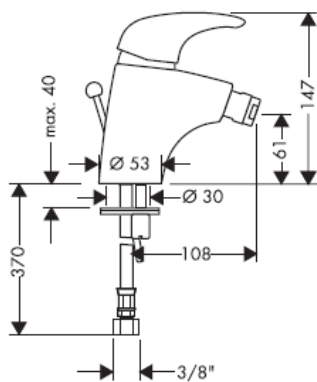

33008000

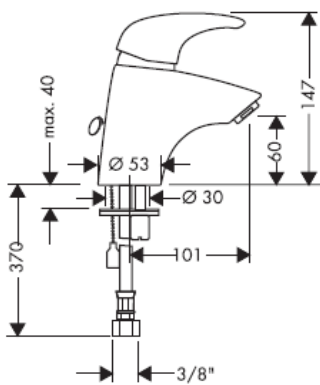

33208000

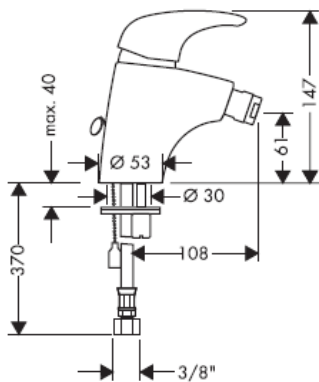

33006000

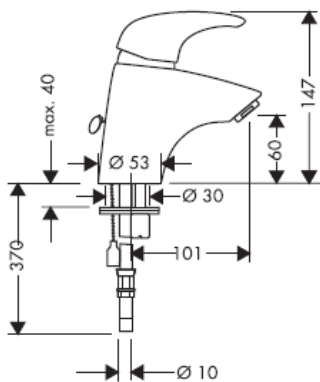

33007000

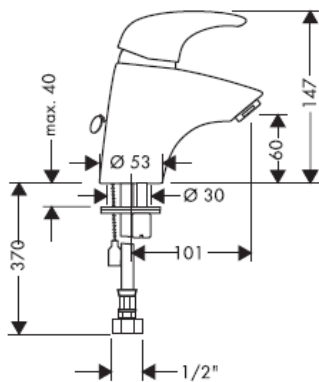

33011000

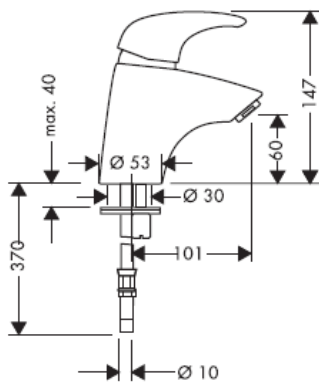

Montaža priključne cevi

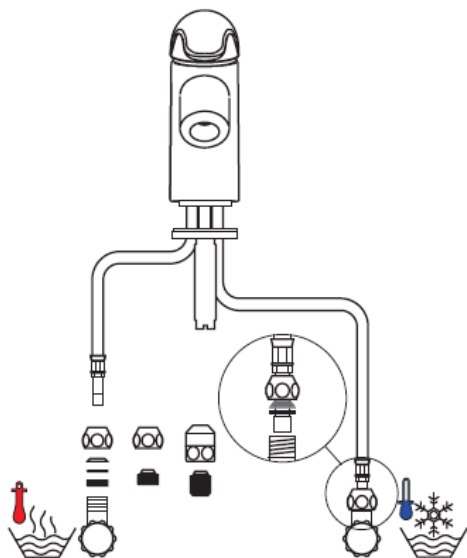
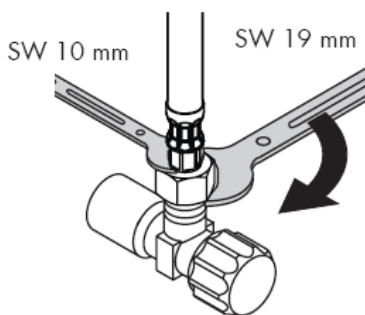
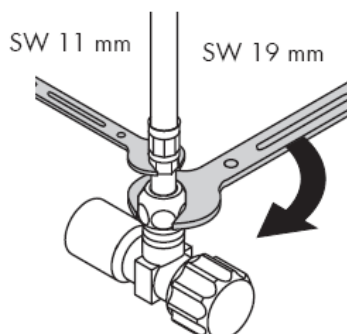
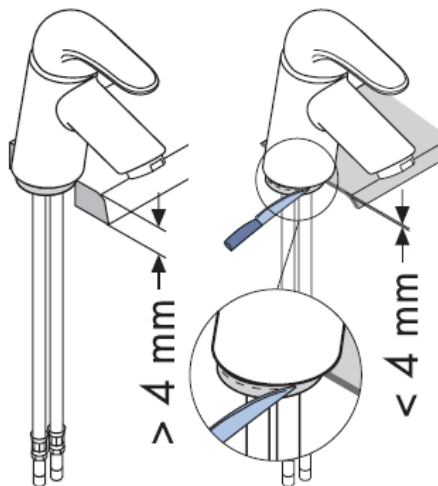
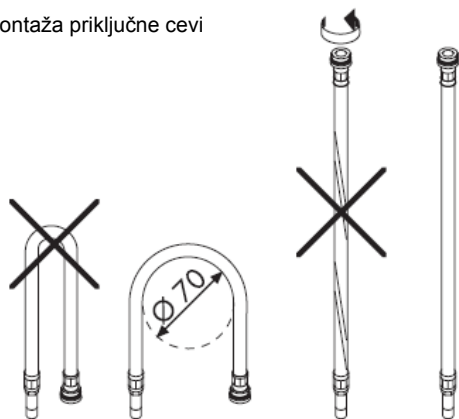

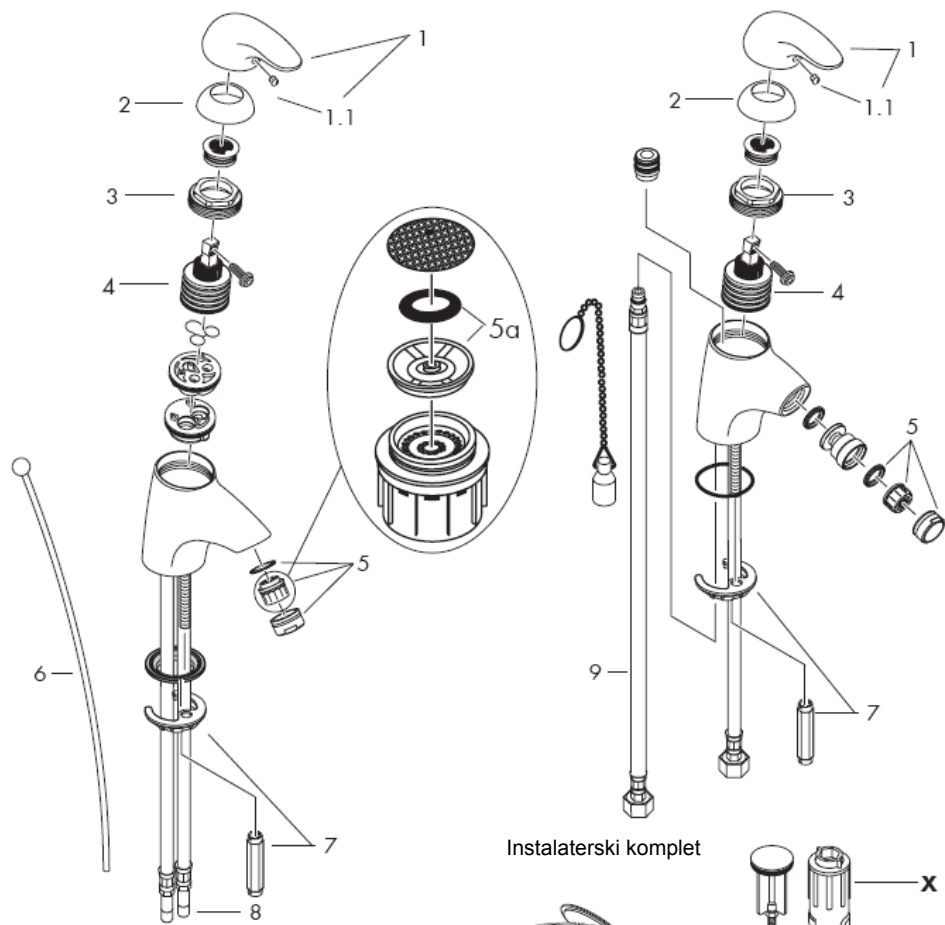

Instalaterski komplet

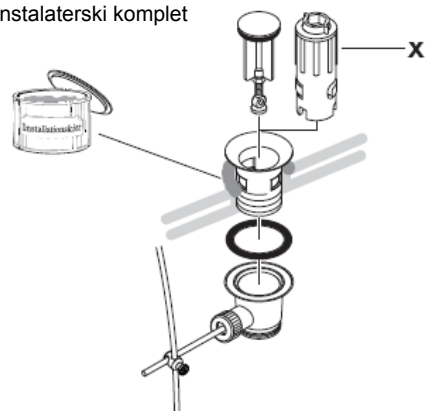

Pažnja! Armatura mora biti postavljena, isprana i testirana prema važećim normama!

Montaža

- 1 Isperite cevi dovoda.
- 2 Postavite armaturu uključujući zaptivnu podlošku na umivaonik / bide.
- 3 Podlošku i stezni disk postavite preko priključne cevi i klina s navojima, pa pričvrstite navrtkom.
- 4 Spojite priključna creva na ugaone ventile; hladna voda desno – vruća levo.
- 5 33001000/32002XXX/33200XXX/33202XXX: Spojite vučnu šipku s odvodnim ventilom.

Velika razlika u pritisku između vruće i hladne vode mora biti izbalansirana.

Rukovanje

Mešač se otvara podizanjem ručice.
Okretanje ulevo = vruća voda,
Okretanje udesno = hladna voda.

Tehnički podaci

Ove armature imaju serijski ugrađen waterdimmer® (ograničavač protoka vode).

Protok vode sa waterdimmer-om: 7 l/min 0,3 MPa

Protok vode bez waterdimmer-a: 12 l/min 0,3 MPa

Radni pritisak: max. 1 MPa

Preporučeni radni pritisak: 0,1 – 0,5 MPa

Probni pritisak: 1,6 MPa

(1 MPa = 10 bar = 147 PSI)

Preporučena temperatura vruće vode: max 80° C

Preporučena temperatura vruće vode: 60° C

Hansgrohe jednoručni mešači se mogu koristiti s hidraulički i termički kontrolisanim protočnim bojlerima, ako je pritisak najmanje 0,15 MPa.

Ako dolazi do problema sa protočnim bojlerima ili ne izlazi dovoljno vode, waterdimmer® (ograničavač protoka vode 5a) lociran iza aeratora mora biti uklonjen.

Da bi ste podesili ograničavač vruće vode na jednoručnim mešačima, molimo Vas da pogledate stranicu 8.

Podešavanje nije potrebno ako koristite protočni bojler.

Rezervni delovi vidi stranu 5

1	Ručica	33091000
1.1	Čepovi ručice	94191000
2	kapica	94192000
	Pozlaćena kapica	94192990
3	Navrtka	94194000
4	Kartuša kompl.	92730000
5	Aerator kompl. (10)	13912000
	Aerator kompl. gold	94980990
	Aerator kompl. (6 l/min)	96788000
6	Vučna šipka	92620000
	Vučna šipka dezen zlatna	92620990
7	Kompletna pričvrtna garnitura	96016000
8	Priključno crevo	95001000
9	Priključno crevo	97206000

Poseban pribor

Poseban pribor

Srpski

Ispitni znak

	DVGW	P-IX	SVGW	ACS	NF	WRAS	KIWA
33001000	X	P-IX 8388/IA	X			X	X
33002XXX	X	P-IX 8388/IA	X		X		X
33006000	X	P-IX 8388/IA	X				X
33007000							
33008000	X	P-IX 8388/IA	X		X		X
33011000							
33200XXX	X	P-IX 8388/IA	X			X	X
33202XXX	X	P-IX 8388/IA	X		X		X
33208000	X	P-IX 8388/IA	X		X		X

Ograničavač vruće vode: temperatura vruće vode 60 C, temperatura hladne vode 10 C, pritisak 0,3 MPa.

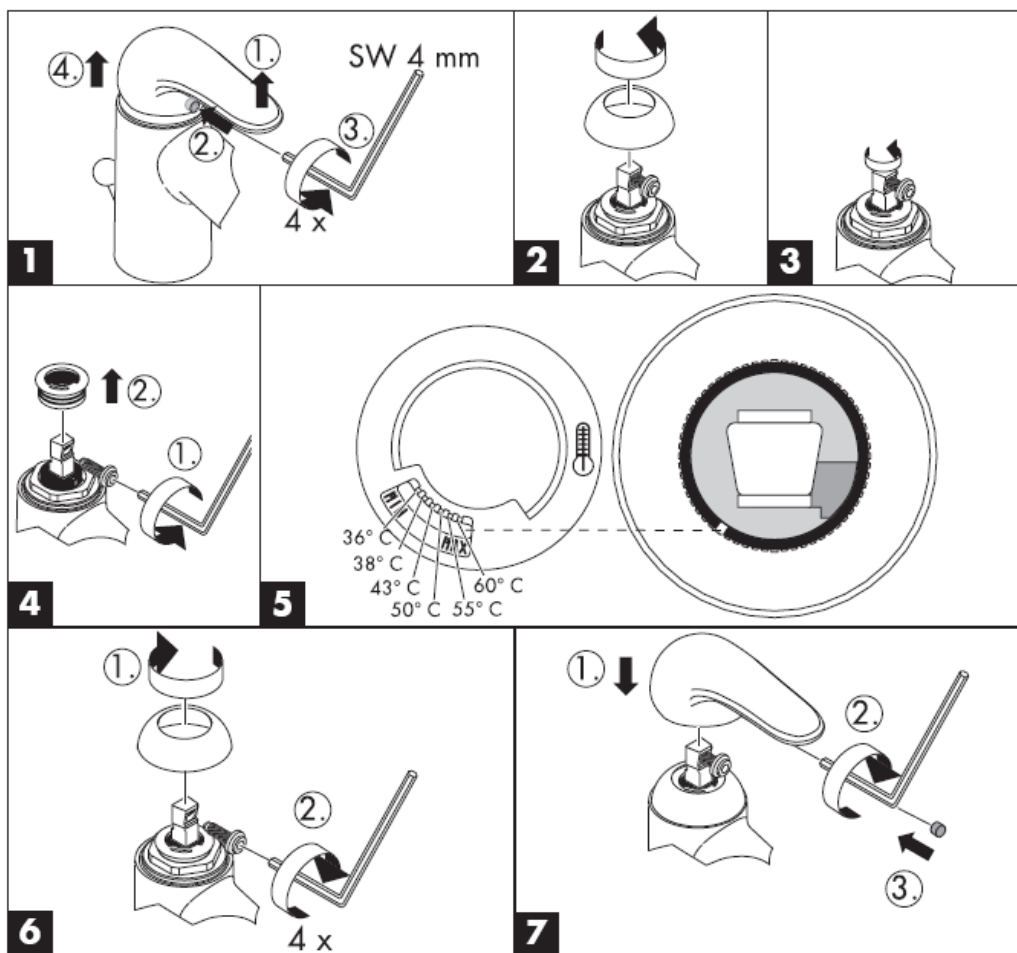

Čišćenje

Rubit® - ručni sistem za čišćenje omogućuje odstranjivanje kamenca s rupica uobličavača mlaza, jednostavnim trljanjem.



hansgrohe

Hansgrohe · Postfach 1145 · D-77761 Schiltach · Telefon +49 (0) 78 36/51-1282 · Telefax +49 (0) 7836/511440
E-Mail: info@hansgrohe.com · Internet: www.hansgrohe.com

05/2006
9.07956.04
Stpski

Montasjeveiledning



Talis E

33001000/33002XXX/33006000
33007000/33008000/33011000



Talis E

33200XXX/33202XXX/32208000

hansgrohe

33001000

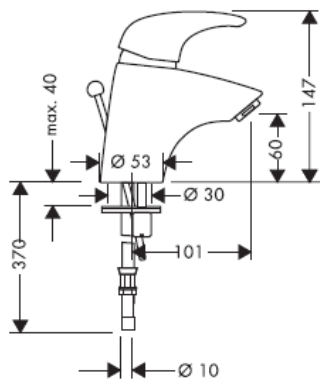

33200XXX

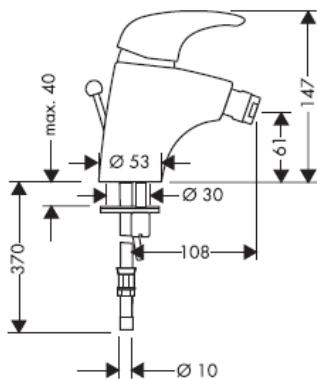

33002XXX

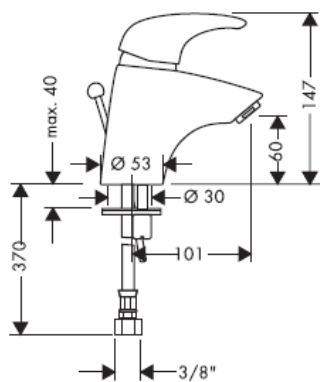

33202XXX

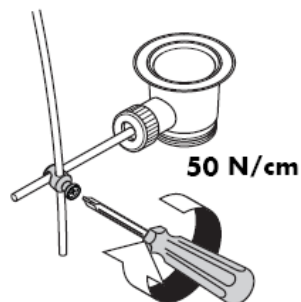
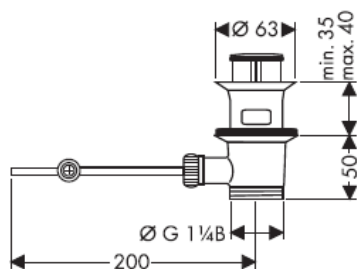
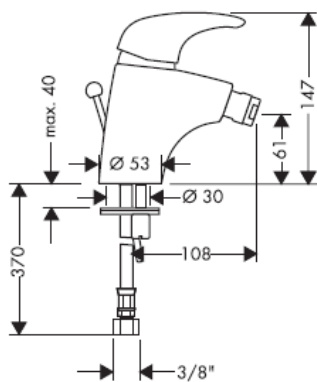

33008000

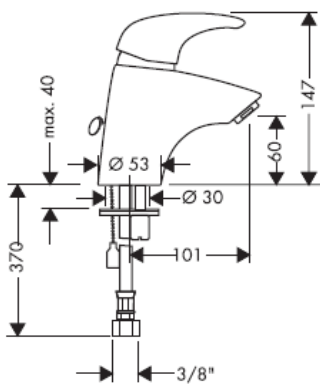

33208000

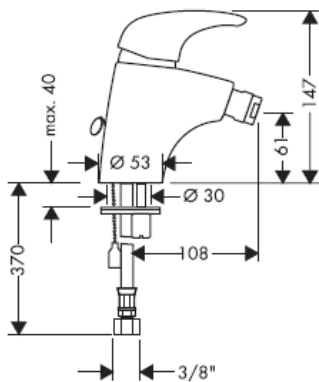

33006000

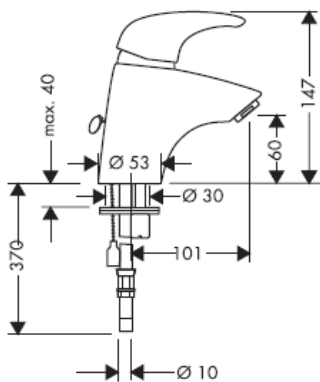

33007000

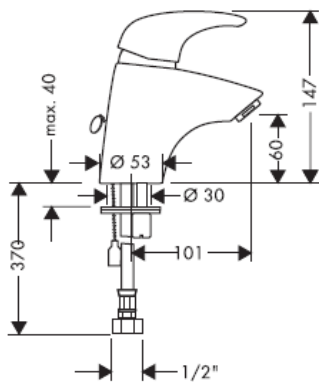

33011000

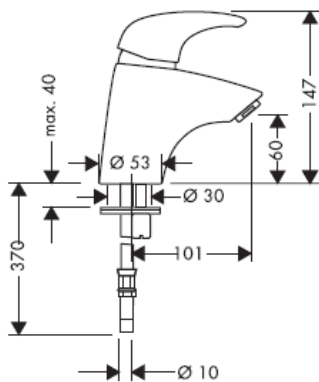

Montasje tilkoblingsslange

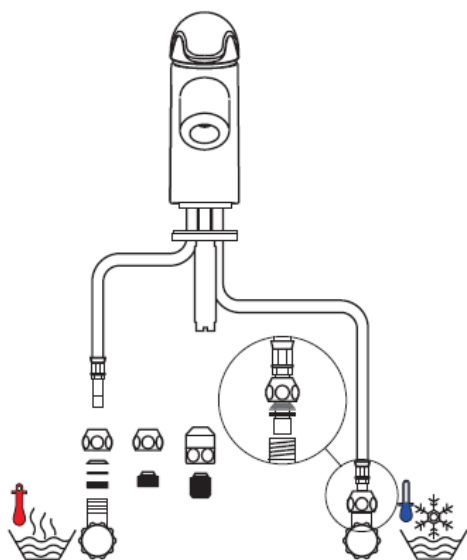
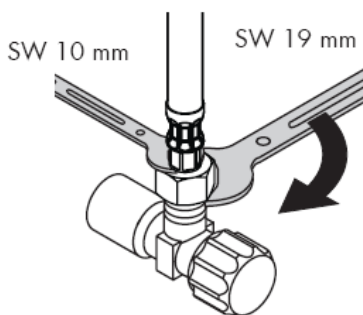
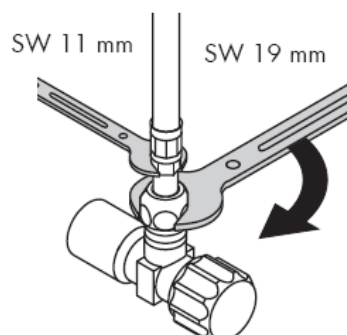
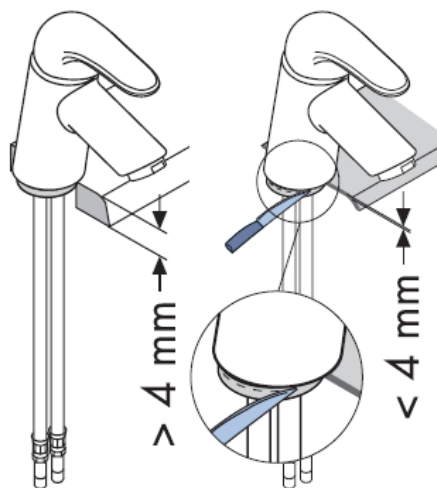
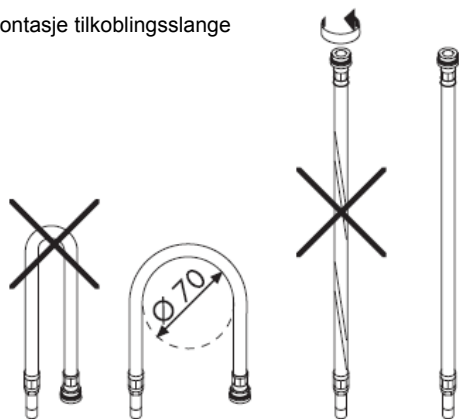

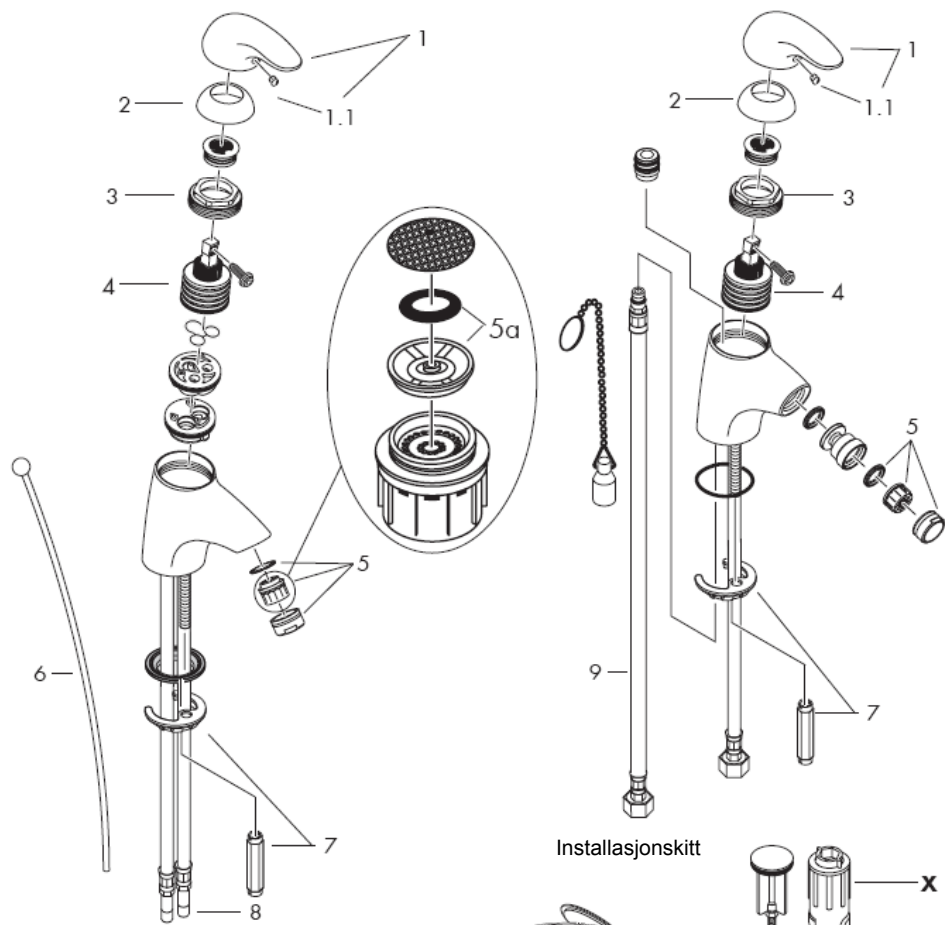

Installasjonskitt

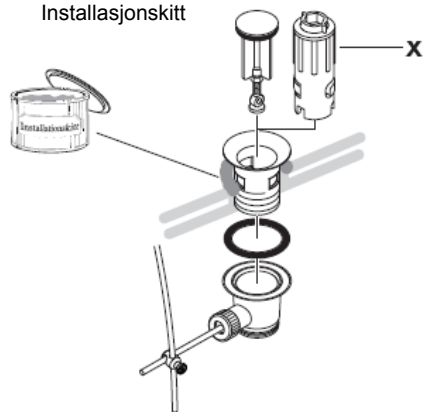

Obs! Armaturen skal monteres iht. gyldige standarder. De skal spyles og sjekkes!

Montasje

- 1 Forsyningsledninger spyles faglig korrekt.
- 2 Armatur settes med mellomlag inn i vaskebord / bidet.
- 3 Underlagsskive og festeskive skyves over tilkoblingsrørets settskrue og trekkes fast med mutteren.
- 4 Tilkoblingslanger kobles til hjørneventiler, kaldt høyre - varm venstre.
- 5 33001000/32002XXX/33200XXX/33202XXX: Trekkstang kobles til avløpsventil.

Store trykkdifferanser mellom kaldt- og varmtvannstilkoblinger skal utlignes.

Betjening

Blandebatteriet åpnes ved løfting av grepet. Drei til venstre = varmt vann, drei til høyre = kaldt vann.

Tekniske data

Armatur er standardmessig utstyrt med

Waterdimmer®

(gjennomstrømningsbegrensere)

Gjennomstrømningsytelse med waterdimmer:

7 l/min 0,3 MPa

Gjennomstrømningsytelse uten waterdimmer

12 l/min 0,3 MPa

Driftstrykk max. 1 MPa

Anbefalt driftstrykk: 0,1 – 0,5 MPa

Prøvetrykk 1,6 MPa

(1 Mpa = 10 bar = 147 PSI)

Anbefalt temperatur for varmt vann max 80° C

Anbefalt temperatur for varmt vann 60° C

Armaturer fra Hansgrohe kan brukes sammen med hydraulisk og termisk strypte gjennomstrømningsovner når gjennomstrømningsstrykket er på minst 0,15 Mpa.

Ved problemer med gjennomstrømningsovnen, eller når man ønsker en større vanngjennomstrømning, kan Waterdimmer® (gjennomstrømningsbegrensere 5a) fjernes. Den sitter bak luftdysene.

Enhåndblandebatteri med varmtvannsbegrensning. For justering se side8. I forbindelse med en gjennomstrømningsovner er det ikke nødvendig med varmtvannsbegrensning.

Servicedeler se side 5

1	Grep	33091000
1.1	Grepplugg	94191000
2	Kappe	94192000
	Kappe gull	94192990
3	Mutter	94194000
4	Kartusj	92730000
5	Luftsprudler kpl. (10)	13912000
	Luftsprudler kpl. gold	94980990
	Luftsprudler kpl. (6 l/min)	96788000
6	Trekkstang	92620000
	Trekkstang dezen zlatna	92620990
7	Skafffeste	96016000
8	Tilkoblingsslange	95001000
9	Tilkoblingslange	97206000

Ekstratilbehør

X sett med montasjenøkler 58085000 (ikke med i leveransen)

Norsk

X sett med montasjenøkler 58085000 (ikke med i leveransen)

	DVGW	P-IX	SVGW	ACS	NF	WRAS	KIWA
33001000	X	P-IX 8388/IA	X			X	X
33002XXX	X	P-IX 8388/IA	X		X		X
33006000	X	P-IX 8388/IA	X				X
33007000							
33008000	X	P-IX 8388/IA	X		X		X
33011000							
33200XXX	X	P-IX 8388/IA	X			X	X
33202XXX	X	P-IX 8388/IA	X		X		X
33208000	X	P-IX 8388/IA	X		X		X

Varmtvannsbegrensning: Varmtvanns-temperatur 60 C, kaldtvanns-temperatur 10 C,
gjennomstrømningstrykk 0,3 bar.

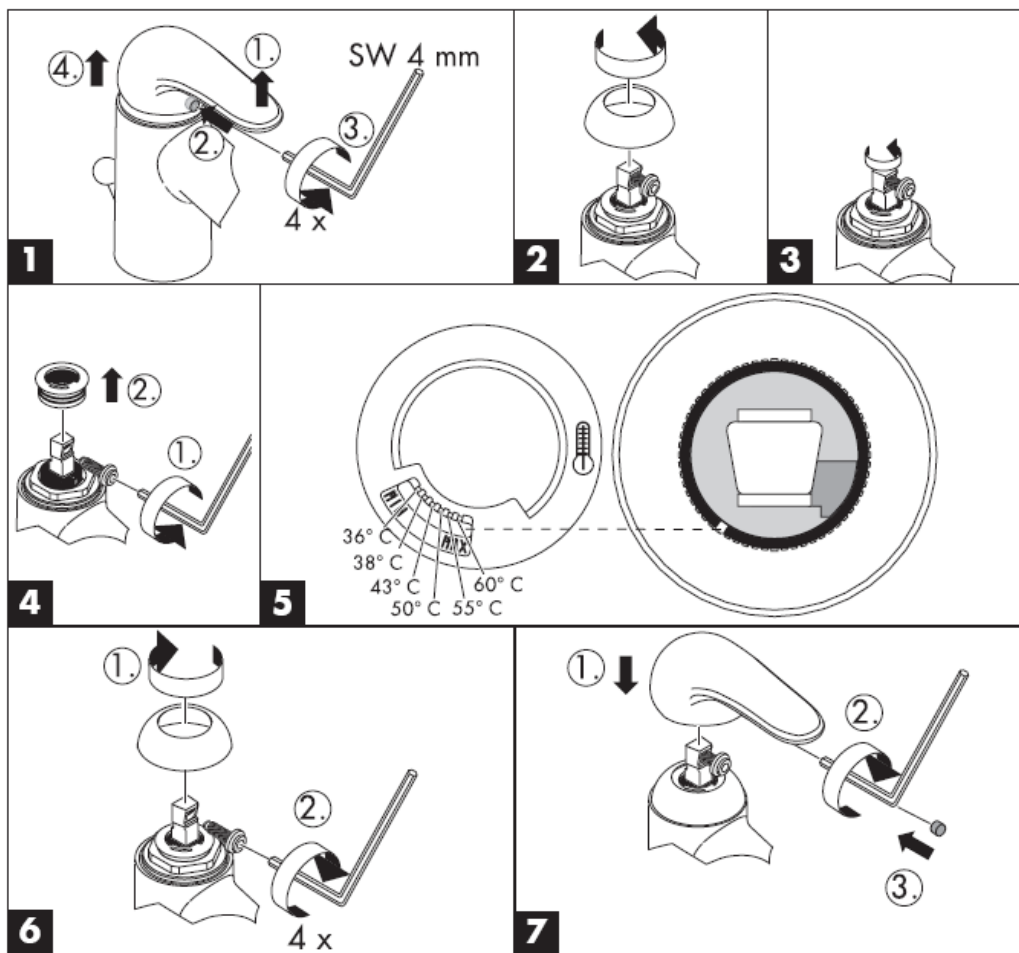

Rengjøring

Ved hjelp av Rubit®, en manuell rengjøringsfunksjon, kan man fjerne kalk fra stråleformere ved enkel gnikking.



hansgrohe

Hansgrohe · Postfach 1145 · D-77761 Schiltach · Telefon +49 (0) 78 36/51-1282 · Telefax +49 (0) 7836/511440
E-Mail: info@hansgrohe.com · Internet: www.hansgrohe.com

05/2006
9.07956.04
Norsk

РЪКОВОДСТВО ЗА МОНТАЖ



Talis E

33001000/33002XXX/33006000
33007000/33008000/33011000



Talis E

33200XXX/33202XXX/32208000

hansgrohe

33001000

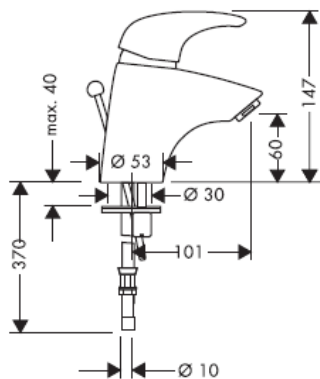

33200XXX

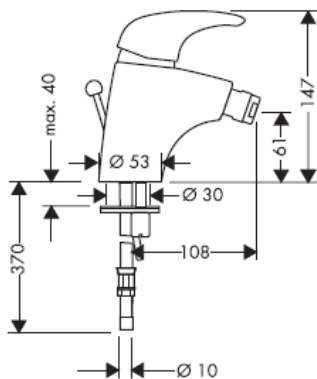

33002XXX

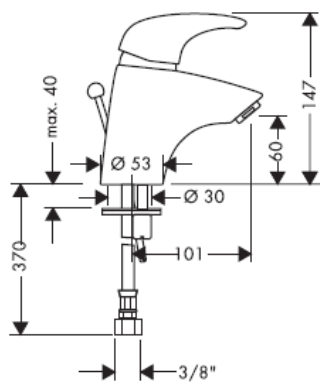

33202XXX

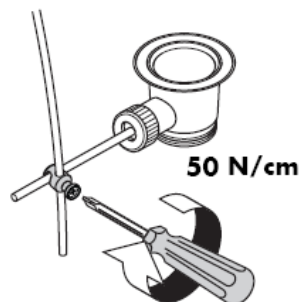
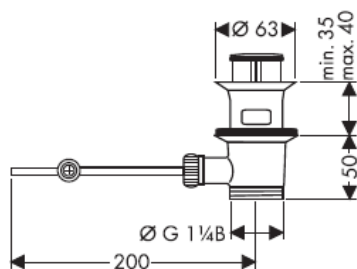
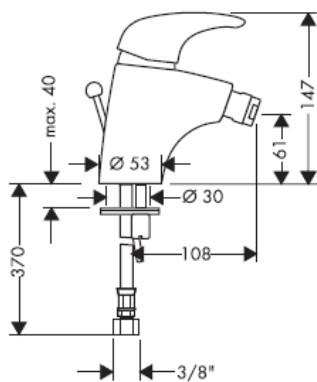

33008000

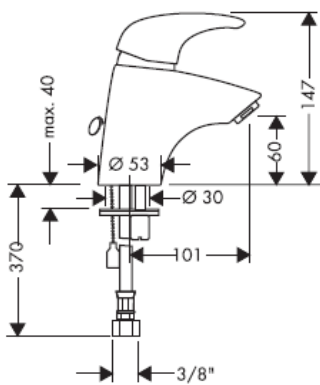

33208000

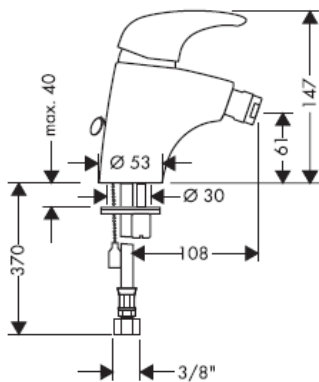

33006000

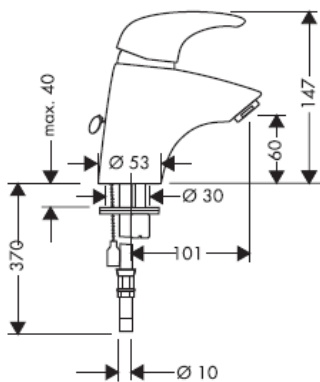

33007000

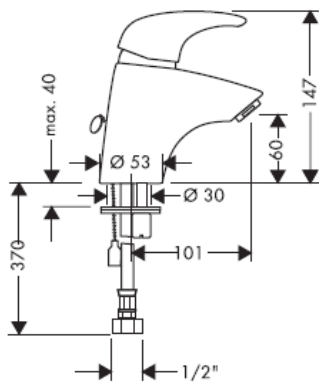

33011000

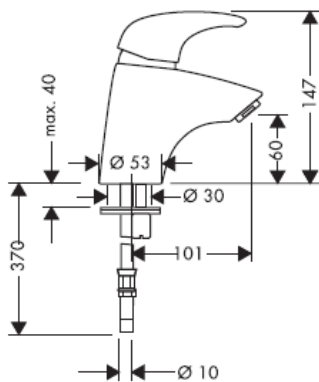

Монтаж на свързващия маркуч

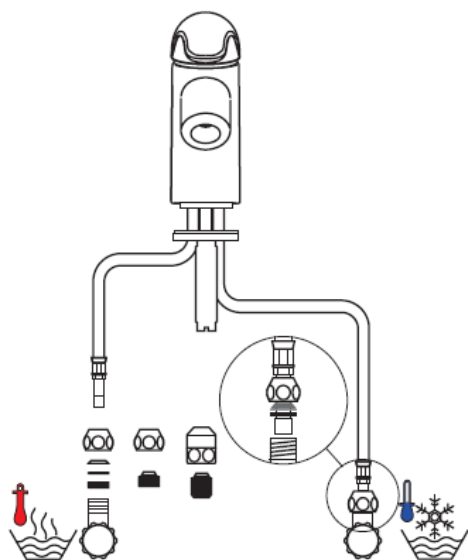
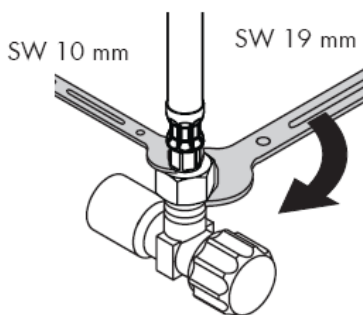
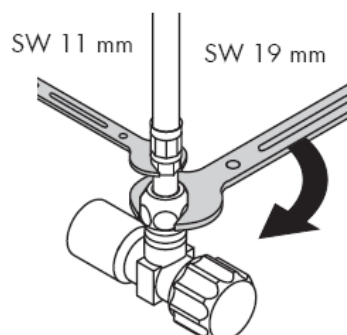
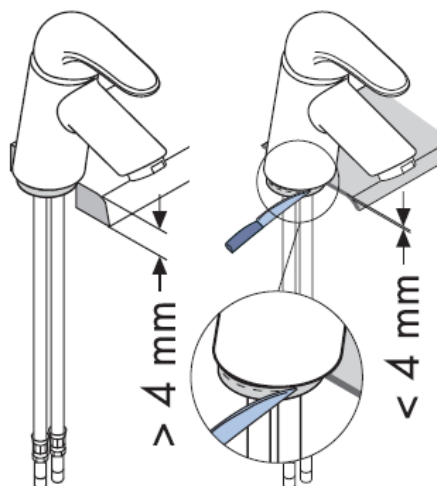

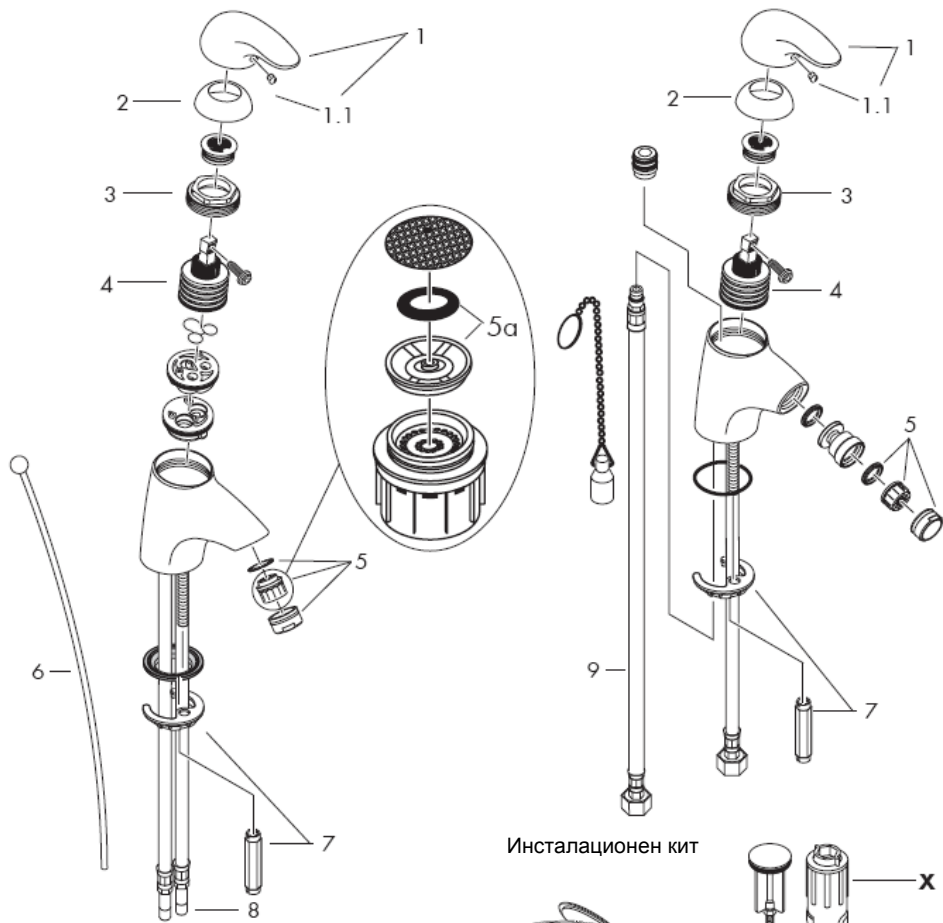

Инсталционен кит

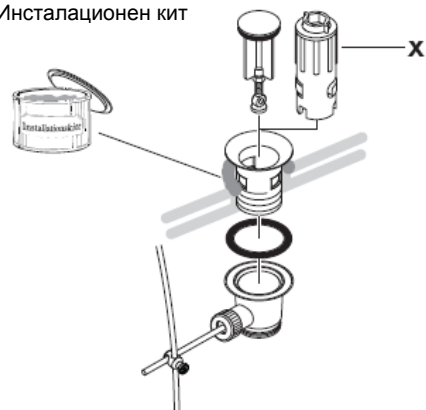

Внимание! Арматурата трябва да се монтира, промие и провери в съответствие с валидните норми!

Монтаж

- 1 Промийте захранващите тръбопроводи съобразно изискванията.
- 2 Поставете арматурата с подложката в умивалника / бидето.
- 3 Поставете подложна шайба и скрепителна шайба върху свързващите тръби и щифта с резба и затегнете с гайка.
- 4 Свържете свързващите маркучи към ъглови клапани, студено отцясно – топло отляво.
- 5 33001000/32002XXX/33200XXX/
33202XXX: Свържете съединителната щанга с клапана за отвеждане.

Големите разлики в налягането между изводите за студената и топлата вода трябва да се изравняват.

Обслужване

След повдигане на дръжката смесителят се отваря. Завъртане наляво = топла вода, Завъртане надясно = студена вода.

Технически данни

Арматурата е оборудвана серийно с Waterdimmer® (ограничител на протичане).

Мощност на потока с Waterdimmer(ограничител на протичане):
7 l/min 0,3 MPa

Мощност на потока без Waterdimmer(ограничител на протичане):
12 l/min 0,3 MPa

Работно налягане: max. 1 MPa
Препоръчително работно налягане: 0,1 – 0,5 MPa

Контролно налягане: 1,6 MPa
(1 MPa = 10 bar = 147 PSI)

Препоръчителна температура на горещата вода: max 80° C

Препоръчителна температура на горещата вода: 60° C

Смесителите с една ръкохватка на Hansgrohe могат да се използват във връзка с хидравлично и термично управляеми проточни нагреватели, ако хидравличното налягане е минимум 0,15 МПа.

При проблеми с проточния нагревател или когато желаете по-голяма пропускателна способност на водата, може да отстраните Waterdimmer® (ограничителя на протичане 5a), който се намира зад аератора.

Смесител с една ръкохватка с ограничител за топлата вода, юстирането вижте на стр. 8. Във връзка с проточни нагреватели не е необходима блокировка за топлата вода.

Сервизни части вижте стр. 5

1	Ръкохватка	33091000
1.1	Пробка на ръкохватката	94191000
2	Капачка	94192000
	Капачка злато	94192990
3	Гайка	94194000
4	Гилзи компл.	92730000
5	Аератор компл. (10)	13912000
	Аератор компл. gold	94980990
	Аератор компл. (6 l/min)	96788000
6	Съединителна щанга	92620000
	Съединителна щанга dezen zlatna	92620990
7	Закрепване на шийката	96016000
8	Свързващ маркуч	95001000
9	Свързващ маркуч	97206000

Специални принадлежности

X Набор монтажни ключове 58085000 (не се съдържа в обема на доставка)

БЪЛГАРСКИ**Контролен знак**

	DVGW	P-IX	SVGW	ACS	NF	WRAS	KIWA
33001000	X	P-IX 8388/IA	X			X	X
33002XXX	X	P-IX 8388/IA	X		X		X
33006000	X	P-IX 8388/IA	X				X
33007000							
33008000	X	P-IX 8388/IA	X		X		X
33011000							
33200XXX	X	P-IX 8388/IA	X			X	X
33202XXX	X	P-IX 8388/IA	X		X		X
33208000	X	P-IX 8388/IA	X		X		X

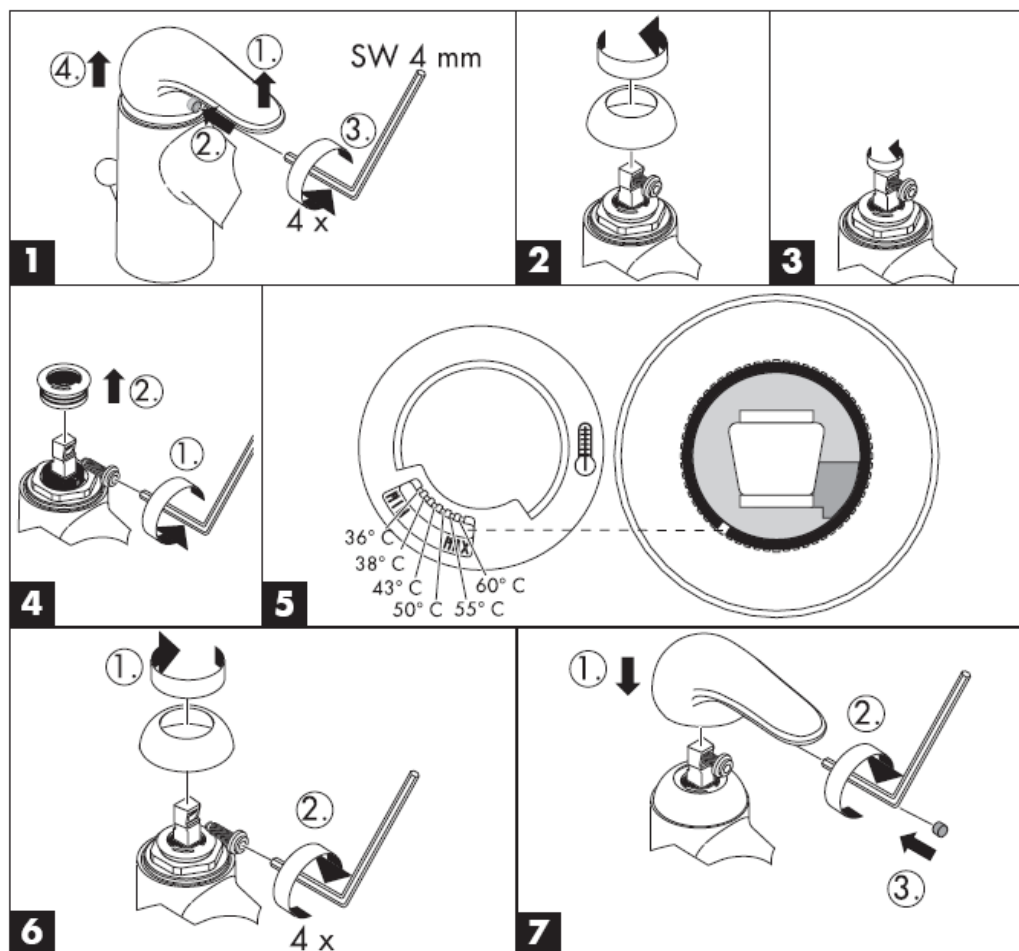

Почистване

С Rubit®, ръчната функция за почистване, приспособленията за почистване на струята могат да се почистват от варовика с просто разтъркване.



hansgrohe

Hansgrohe · Postfach 1145 · D-77761 Schiltach · Telefon +49 (0) 78 36/51-1282 · Telefax +49 (0) 7836/511440
E-Mail: info@hansgrohe.com · Internet: www.hansgrohe.com

05/2006
9.07956.04
БЪЛГАРСКИ

Udhëzime rreth montimit



Talis E

33001000/33002XXX/33006000
33007000/33008000/33011000



Talis E

33200XXX/33202XXX/32208000

hansgrohe

33001000

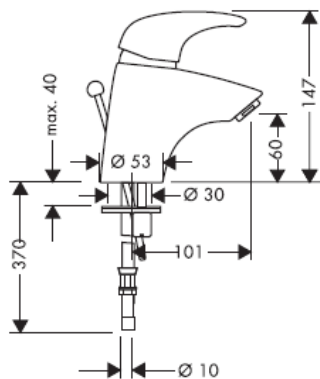

33200XXX

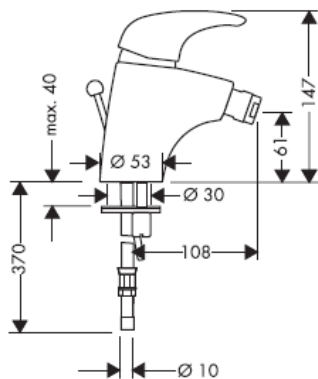

33002XXX

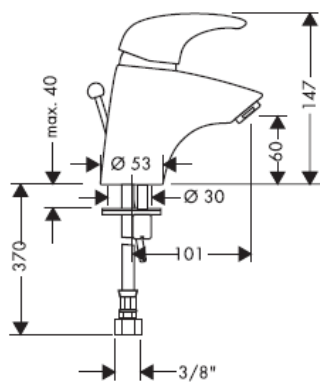

33202XXX

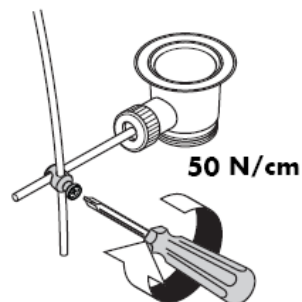
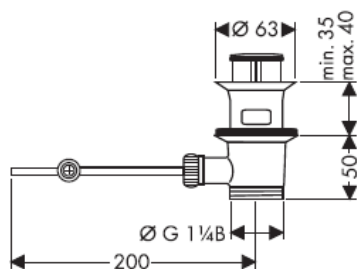
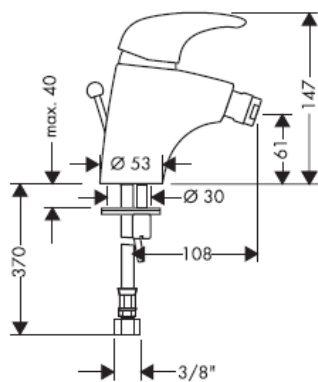

33008000

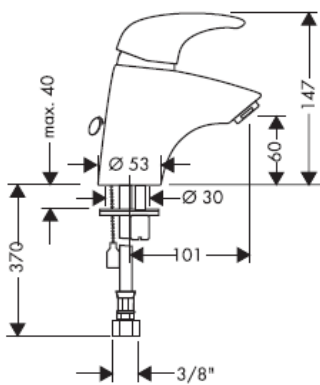

33208000

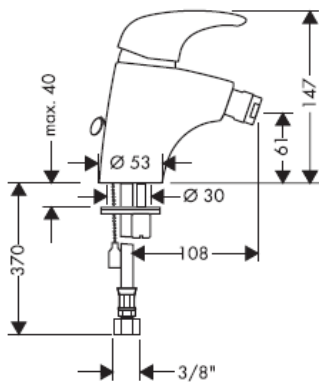

33006000

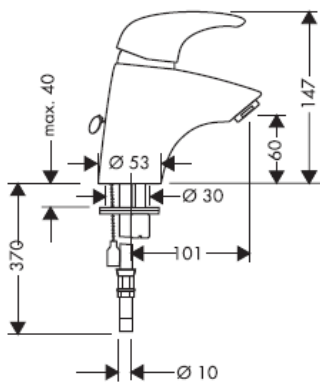

33007000

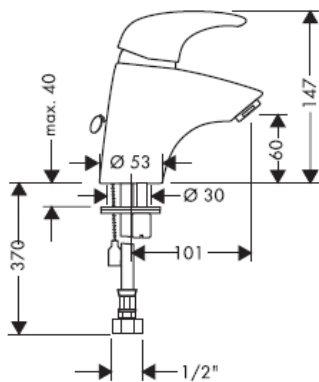

33011000

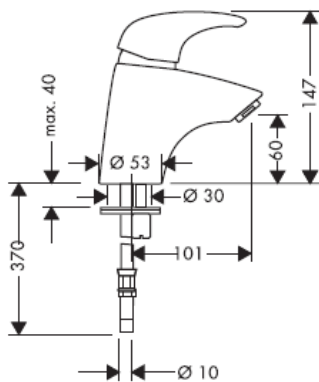

Montimi i zorrës së lidhjes

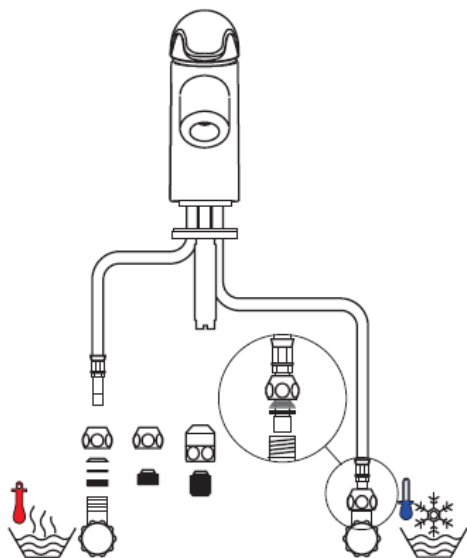
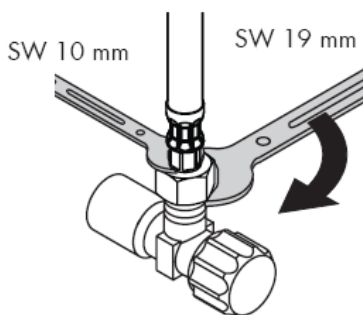
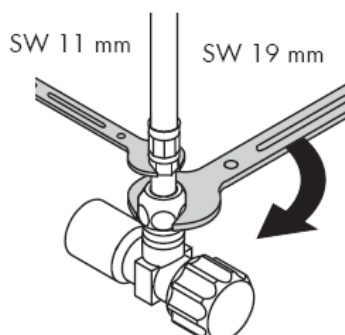
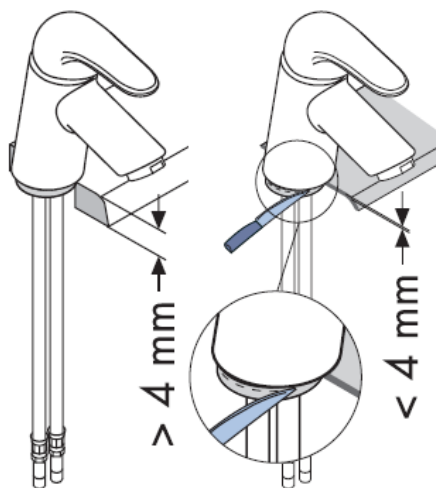
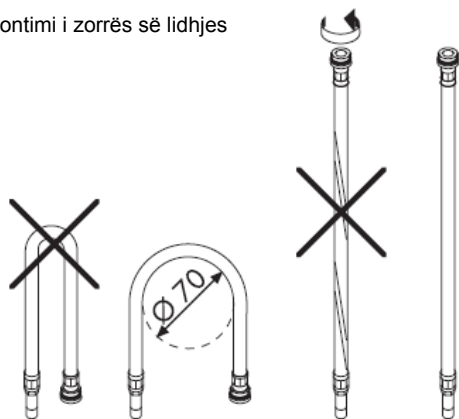

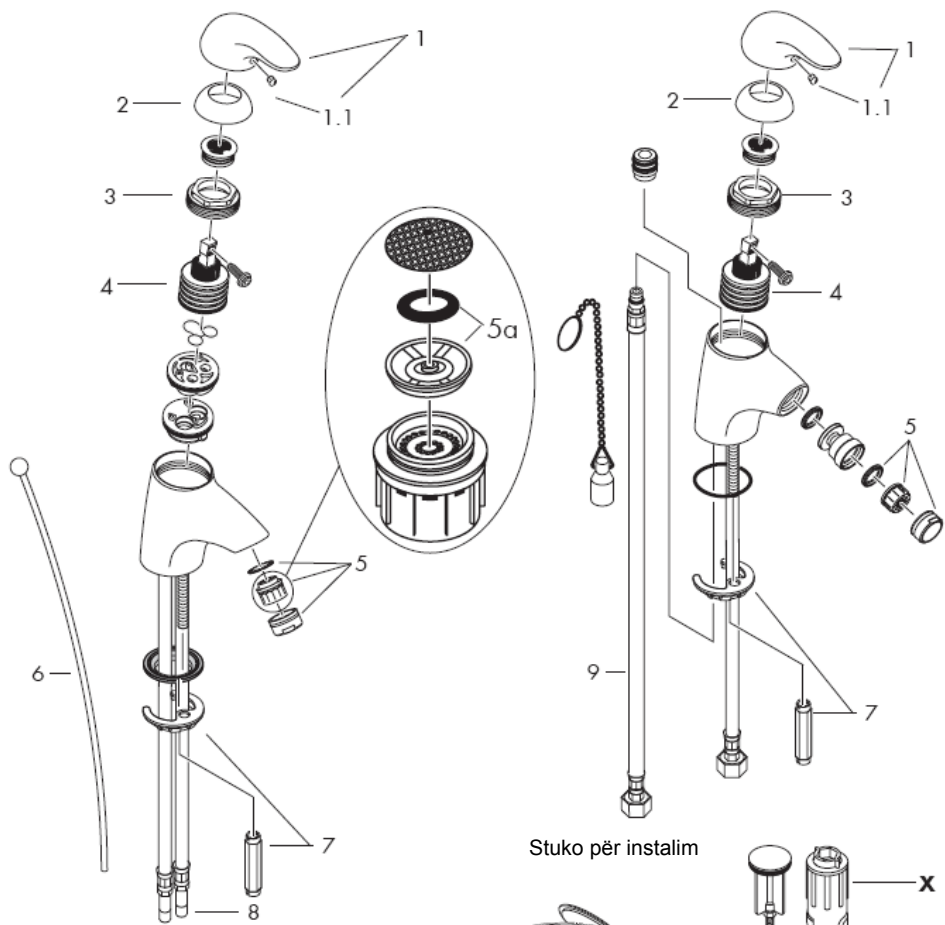

Stuko për instalim

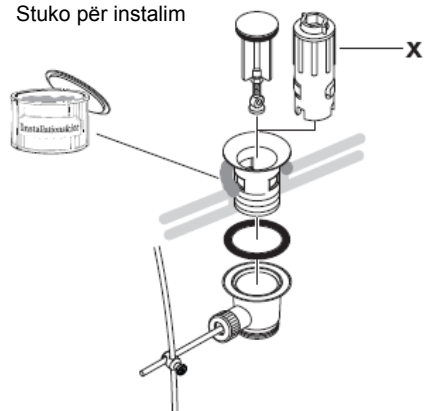

Kujdes! Armatura duhet montuar, shpërlarë dhe kontrolluar në bazë të normave të vlefshme!

Montimi

- 1 Shpërlani në mënyrë profesionale lidhjet.
- 2 Armatura vendoset me një shtresë të ndërmjetme në lavaman / bide.
- 3 Pllaka stabilizuese dhe pllaka përforcuese tërhiqen mbi tubat e lidhjes dhe shtrëngohen me dado.
- 4 Zorra e lidhjes lidhet me ventilin këndor, i ftohtë djathtas - i ngrohtë majtas.
- 5 33001000/32002XXX/33200XXX/
33202XXX: Lidhni shtangën tërheqëse me ventilin për daljen e ujit.

Ndryshimet e mëdha të presionit mes lidhjeve të ujit të ftohtë dhe atij të ngrohtë duhen ekuilibruar.

Përdorimi

Rubineti me ujë të përzier hapet duke ngritur lart dorezën.

Rrotullimi majtas = ujë i ngrohtë,

rrotullimi djathtas = ujë i ftohtë.

Të dhëna teknike

Armatura sipas serisë është e pajisur me Waterdimmer® (Kufizues i rrjedhjes).

Kapaciteti i rrjedhjes me Waterdimmer:
7 l/min 0,3 MPa

Kapaciteti i rrjedhjes pa Waterdimmer:
12 l/min 0,3 MPa

Presioni gjatë punës max. 1 MPa

Presioni i rekomanduar: 0,1 – 0,5 MPa

Presioni për provë: 1,6 MPa

(1 MPa = 10 bar = 147 PSI)

Temperatura e rekomanduar e ujit të ngrohtë:
max 80° C

Temperatura e rekomanduar e ujit të ngrohtë: 60° C

Armaturat me ujë të përzier të Hansgrohe mund të përdoren në kombinim me ngrohës elektrikë të ujit të drejtuar në mënyrë hidraulike ose termike nëse presioni i rrjedhjes është minimumi 0,15 MPa.

Nëse lindin probleme me ngrohësin elektrik të ujit ose nëse dëshironi të keni më shumë vëllim uji, atëherë mund të ç'montohet Waterdimmer® (kufizuesi i rrjedhjes së ujit 5a), i cili ndodhet pas perlatorit..

Rubineti me ujë të përzier me kufizim të ujit të ngrohtë, justimi shih faqen 8.

Në kombinim me ngrohësit elektrikë të ujit nuk ka nevojë për bllokadë të ujit të ngrohtë.

Pjesët e servisit shih faqen _1c 5

1	Dorezë	33091000
1.1	Tapë për dorezën	94191000
2	Mbulesë	94192000
	Mbulesë ari	94192990
3	Dado	94194000
4	Kaseta komplet	92730000
5	Perlator komplet (10)	13912000
	Perlator komplet gold	94980990
	Perlator komplet (6 l/min)	96788000
6	Shtanga tërheqëse	92620000
	Shtanga tërheqëse dezen zlatna	92620990
7	Mbërthimi i shaftit	96016000
8	Zorra e lidhjes	95001000
9	Zorra e lidhjes	97206000

Pajisje të posaçme

X Komplet i çelësave të montimit 58085000
(nuk përfshihet në vëllimin e furnizimit)

Shqib

Shenja e kontrollit

	DVGW	P-IX	SVGW	ACS	NF	WRAS	KIWA
33001000	X	P-IX 8388/IA	X			X	X
33002XXX	X	P-IX 8388/IA	X		X		X
33006000	X	P-IX 8388/IA	X				X
33007000							
33008000	X	P-IX 8388/IA	X		X		X
33011000							
33200XXX	X	P-IX 8388/IA	X			X	X
33202XXX	X	P-IX 8388/IA	X		X		X
33208000	X	P-IX 8388/IA	X		X		X

Kufizimi i ujit të ngrohtë: Temperatura e ujit të ngrohtë 60 C, temperatura e ujit të ftohtë 10 C, presioni i rrjedhjes 0,3 MPa.

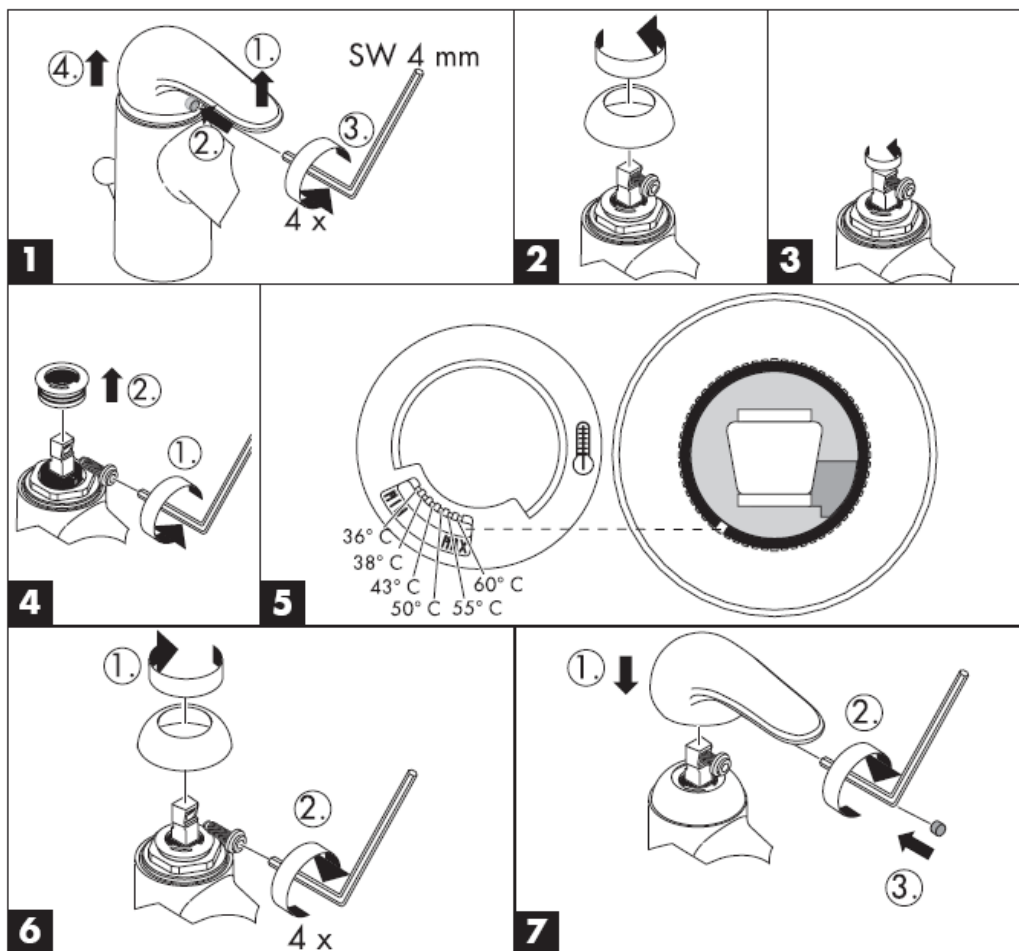

Kufizimi i ujit të ngrohtë: Temperatura e ujit të ngrohtë 60 C, temperatura e ujit të ftohtë 10 C,

Me Rubit®, funksionin manual të pastrimit mund të hiqet kalku me fërkim të thjeshtë nga formuesit e currilit.



hansgrohe

Hansgrohe · Postfach 1145 · D-77761 Schiltach · Telefon +49 (0) 78 36/51-1282 · Telefax +49 (0) 7836/511440
E-Mail: info@hansgrohe.com · Internet: www.hansgrohe.com

05/2006
9.07956.04
Shqip