

AXOR

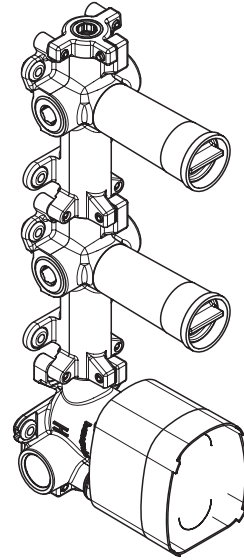

AXOR One™
48720181

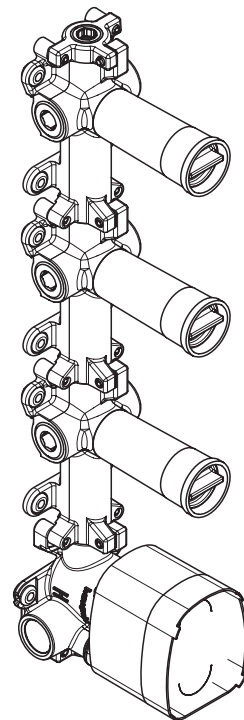

AXOR One™
48710181

EN Installation / User Instructions / Warranty
FR Instructions de montage / Mode d'emploi / Garantie
ES Instrucciones de montaje / Manejo / Garantía

INSTALLATION

ENGLISH

SAFETY NOTES

- ⚠ **WARNING:** To avoid the risk of product failure, property damage, and personal injury, do the following:
- ⚠ This product should be installed by a licensed professional plumber.
- ⚠ This product is for use with drinking water only.
- ⚠ Failure to follow these instructions may result in product failure and property damage, and may void the warranty.

INSTALLATION CONSIDERATIONS

- / Read over these instructions thoroughly before beginning installation. Make sure that you have all tools and supplies needed to complete the installation.
- / Rough valve 48710181 is for use with trim kit 48713XX1 or 48723XX1 (not included). Rough valve 48720181 is for use with trim kit 48712XX1 or 48722XX1 (not included). When the trim kit is installed on the rough valve, an automatically compensating valve (type T) for anti-scald protection for individual fixture fittings, compliant to ASME A112.18.1/CSA B125.1, will be created.
- / To prevent scald injury, the maximum output temperature of the shower valve must be no higher than 120°F (49°C). In Massachusetts, the maximum output temperature can be no higher than 112°F (44°C).

- / Keep this booklet and the receipt (or other proof of date and place of purchase) for this product in a safe place. The receipt is required should it be necessary to request warranty parts.

TECHNICAL INFORMATION

Water pressure	
Recommended	15 - 75 PSI (0.1 - 0.5 MPa)
Maximum	145 PSI (1 MPa)
Hot water temp.	
Recommended	120°-140° F (48° - 60° C)*
Maximum	158°F (70° C)*

- * Please know and follow all applicable local plumbing codes when setting the temperature on the water heater.

FRANÇAIS

CONSIGNES DE SÉCURITÉ

- ⚠ **AVERTISSEMENT :** Afin d'éviter les risques de défaillance du produit, de dommages matériels et de blessures corporelles, veuillez procéder de la manière suivante :
- ⚠ Ce produit devrait être installé par un plombier professionnel certifié.
- ⚠ Ce produit doit être utilisé avec de l'eau potable seulement.
- ⚠ Le non-respect de ces instructions peut entraîner une défaillance du produit et des dommages matériels, ainsi que l'annulation de la garantie.

À PRENDRE EN CONSIDÉRATION POUR L'INSTALLATION

- / Veuillez lire toutes ces instructions avant de procéder à l'installation. Assurez-vous de disposer de tous les outils et du matériel nécessaires pour l'installation.
- / Le pièce intérieure 48710181 requiert dispositif 48713XX1 ou 48723XX1 (non compris). Le pièce intérieure 48720181 requiert dispositif 48712XX1 ou 48722XX1 (non compris) Une valve de compensation automatique pour protection anti-brûlure de raccords de robinetterie individuels, conforme à la norme ASME A112.18.1/CSA B125.1, est obtenue lorsque l'ensemble de garniture est installé.
- / Pour empêcher des blessures par ébullition, la température de sortie maximale du robinet de douche ne doit pas excéder 120°F (49°C). Au Massachusetts, la température de sortie maximale du robinet de douche ne doit pas excéder 112°F (44°C).

- / Conservez ce livret et le reçu (ou une autre preuve sur laquelle figurent la date et l'endroit de l'achat) pour ce produit dans un endroit sûr. Le reçu est requis si vous commandez des pièces sous garantie.

DONNÉES TECHNIQUES

Pression d'eau recommandée	15 - 75 PSI (0.1 - 0.5 MPa)
maximum	145 PSI (1 MPa)
Température d'eau chaude recommandée	120°-140° F (48° - 60° C)*
maximum	158°F (70° C)*

- * Vous devez connaître et respecter tous les codes de plomberie locaux applicables pour le réglage de la température du chauffe-eau.

ESPAÑOL

INDICACIONES DE SEGURIDAD

- ⚠ **ADVERTENCIA:** Para evitar el riesgo de falla del producto, daño a la propiedad y lesiones personales, haga lo siguiente:
- ⚠ Este producto debe ser instalado por un plomero profesional matriculado.
- ⚠ Este producto ha sido creado para su uso exclusivo con agua potable.
- ⚠ No seguir estas instrucciones puede resultar en la falla del producto y daño de la propiedad, y puede anular la garantía.

CONSIDERACIONES PARA LA INSTALACIÓN

- / Antes de comenzar la instalación, lea estas instrucciones detenidamente. Asegúrese de tener las herramientas y los insumos necesarios para completar la instalación.
- / La pieza interior de válvula 48710181 requiere un kit de pieza exterior 48713XX1 o 48723XX1 (no incluido). La pieza interior de válvula 48720181 requiere un kit de pieza exterior 48712XX1 o 48722XX1 (no incluido). Cuando se instala el kit de pieza exterior se crea una válvula de compensación automática para protección anti-escaldadura para accesorios individuales, en cumplimiento con ASME A112.18.1/CSA B125.1.
- / Para evitar escaldaduras, la máxima temperatura de salida de la válvula de la ducha no debe exceder los 120°F (49°C). En Massachusetts, la máxima temperatura de salida de la válvula de la ducha no debe exceder los 112°F (44°C).

- / Mantenga este folleto y el recibo (u otro comprobante del lugar y fecha de compra) de este producto en lugar seguro. El recibo se requiere en caso de ser necesario solicitar piezas bajo garantía.

DATOS TECNICOS

Presión en servicio recomendada	15 - 75 PSI (0.1 - 0.5 MPa)
max.	145 PSI (1 MPa)
Temperatura del agua caliente recomendada	120°-140° F (48° - 60° C)*
max.	158°F (70° C)*

- * Debe conocer y cumplir todos los códigos locales aplicables para ajustar la temperatura del calentador de agua.

AXOR One
48710181

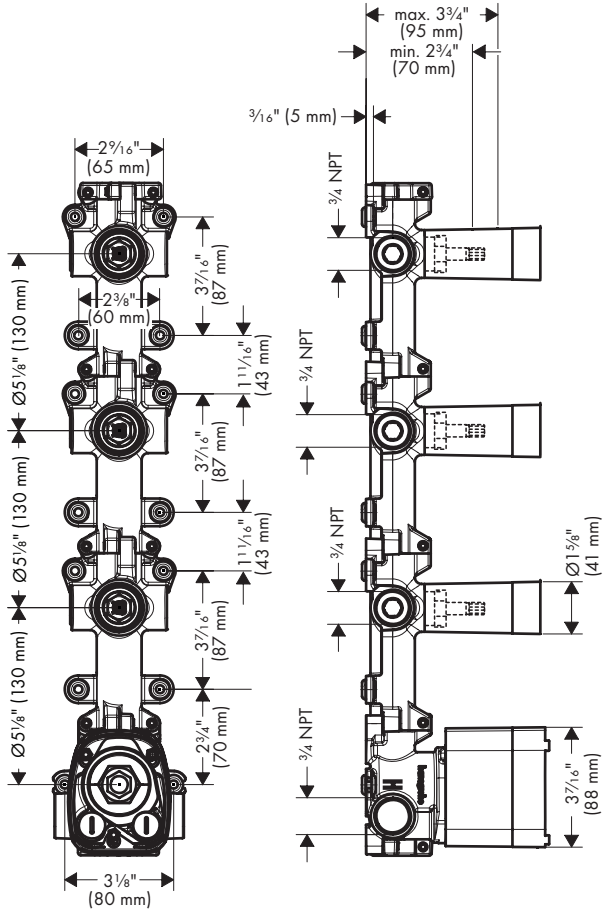

AXOR One
48723XX1

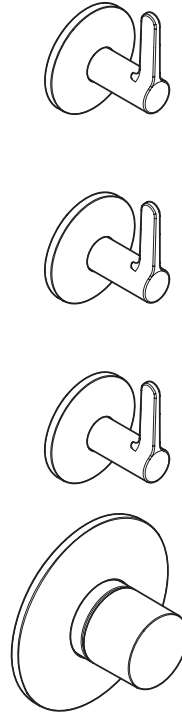

AXOR One
48713XX1

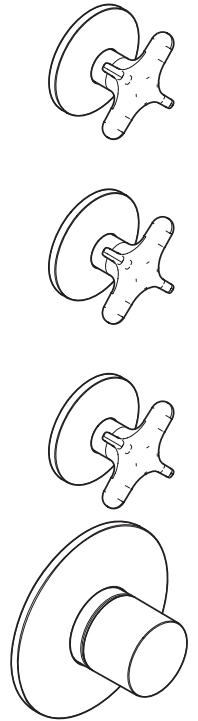

AXOR One
48720181

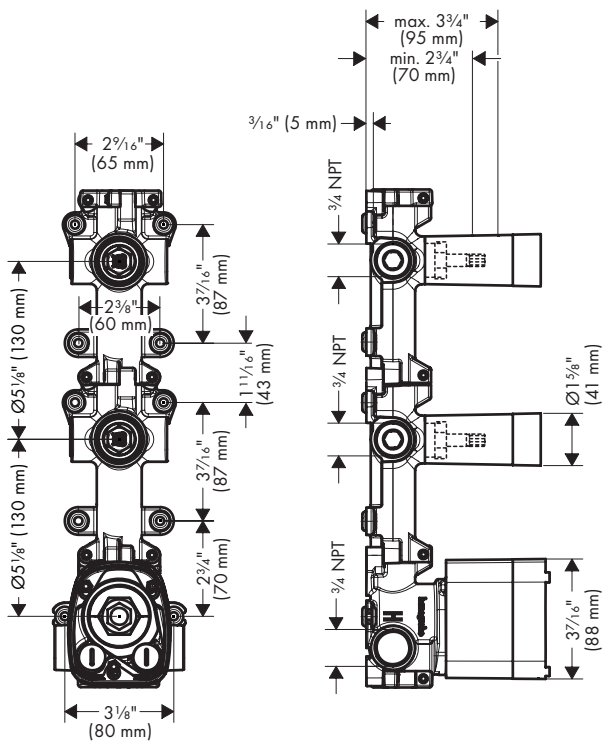

AXOR One
48722XX1

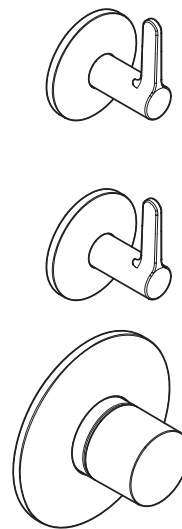

AXOR One
48712XX1

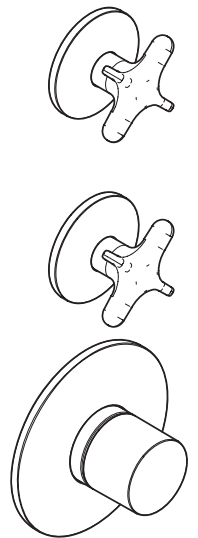

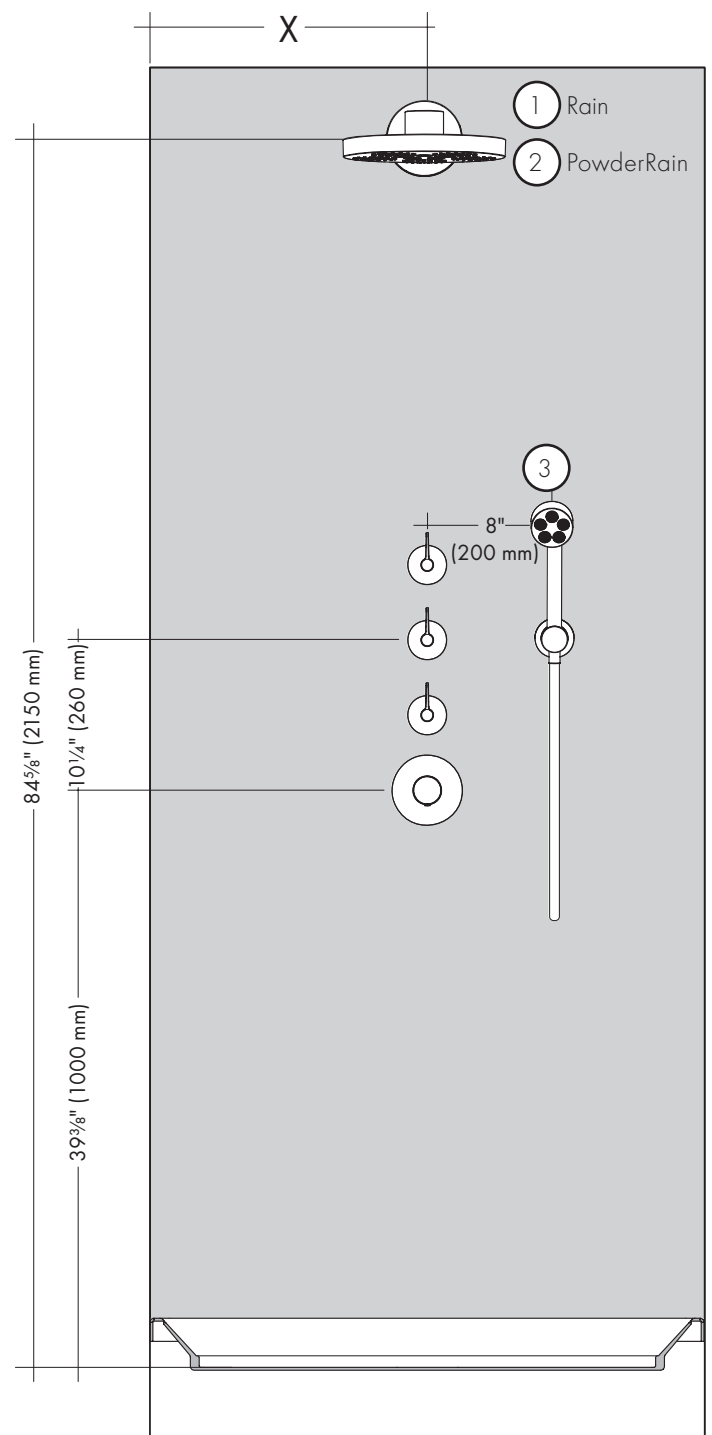
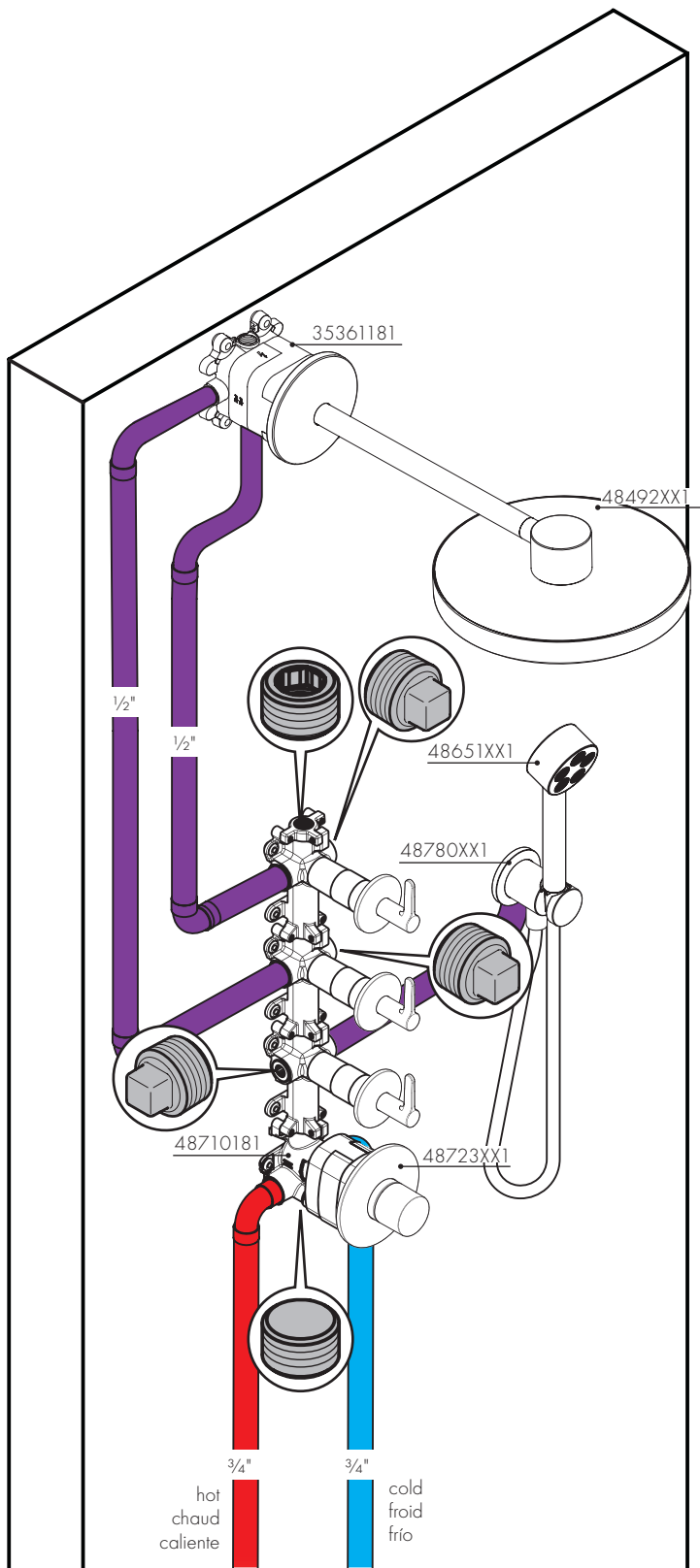

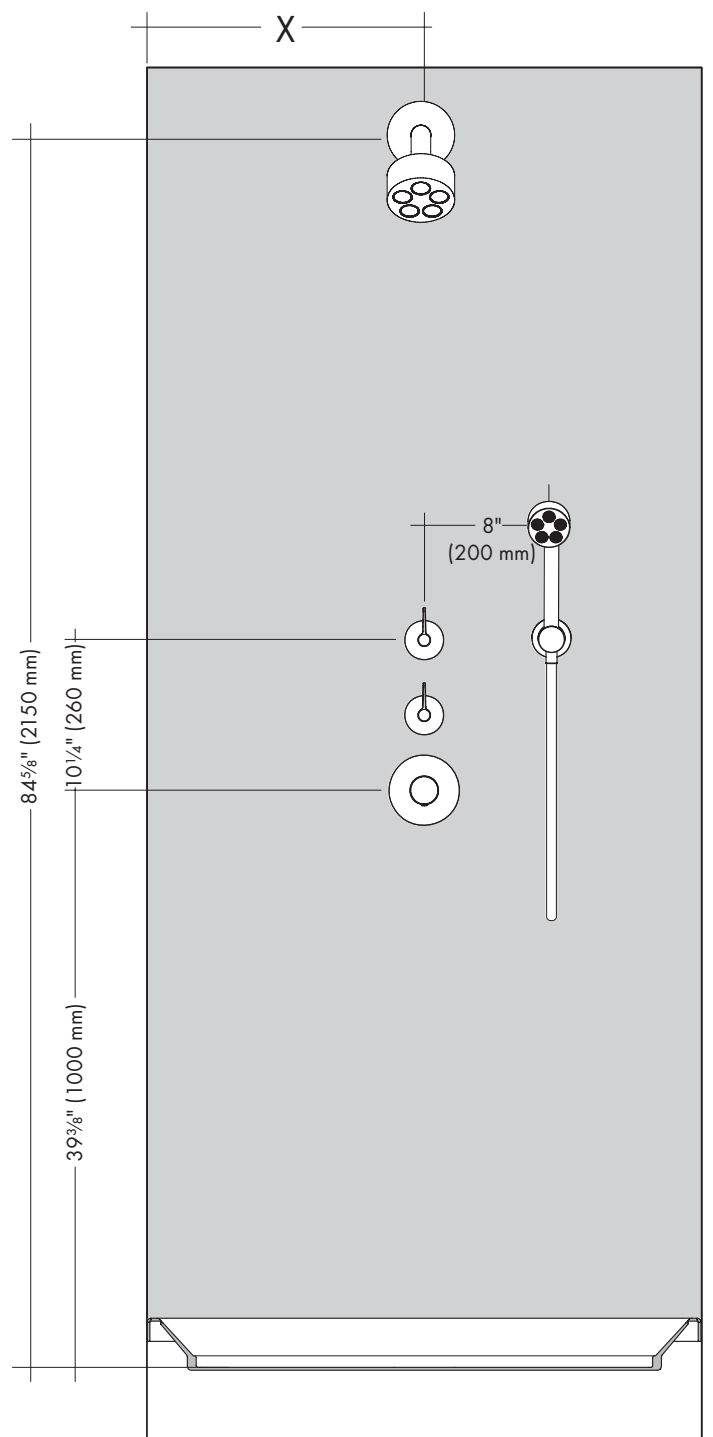
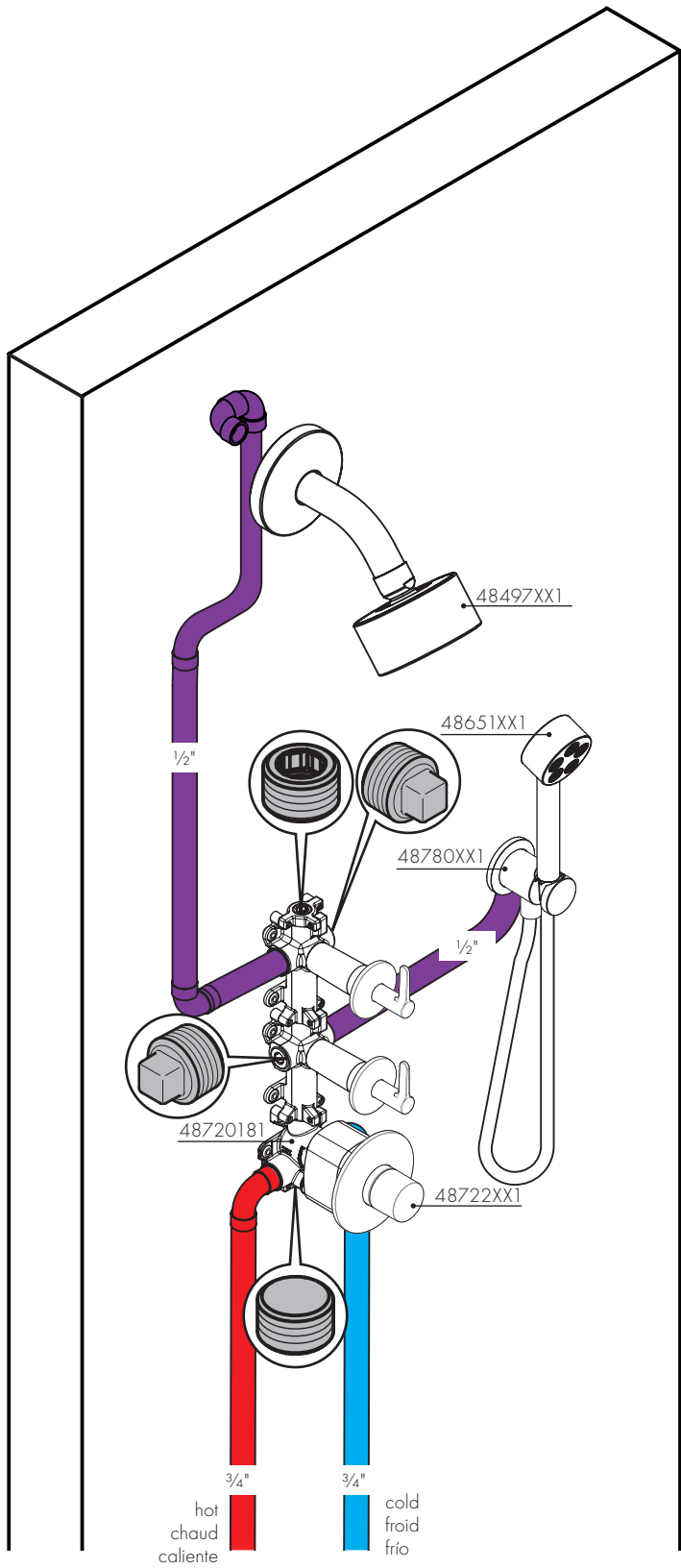

INSTALLATION / INSTALLATION / INSTALACIÓN

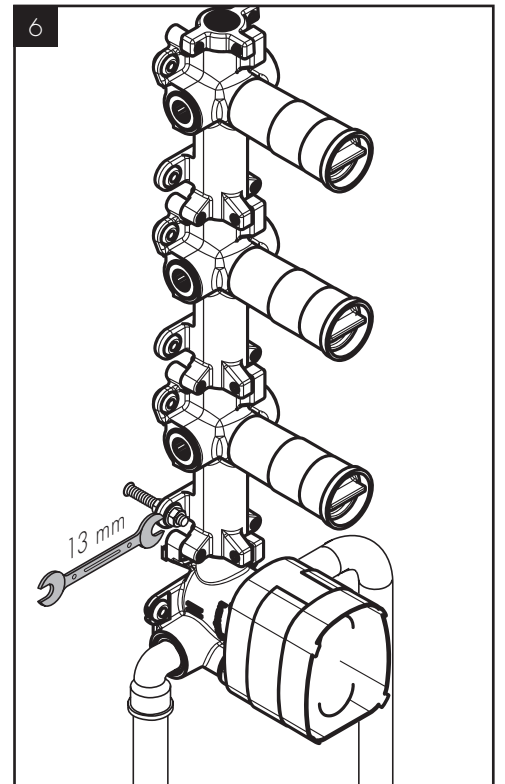
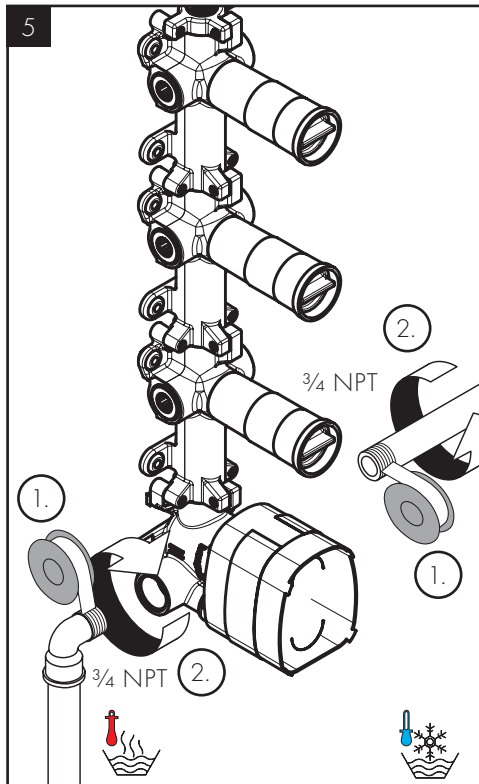
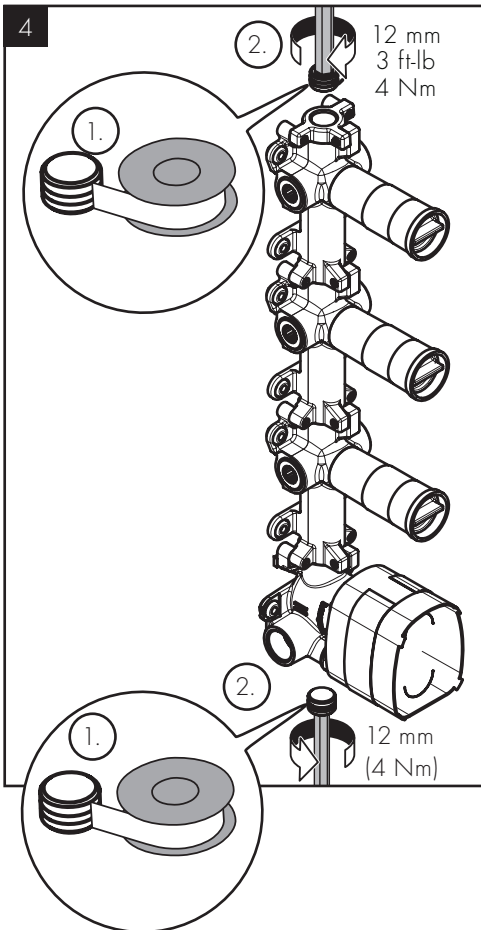
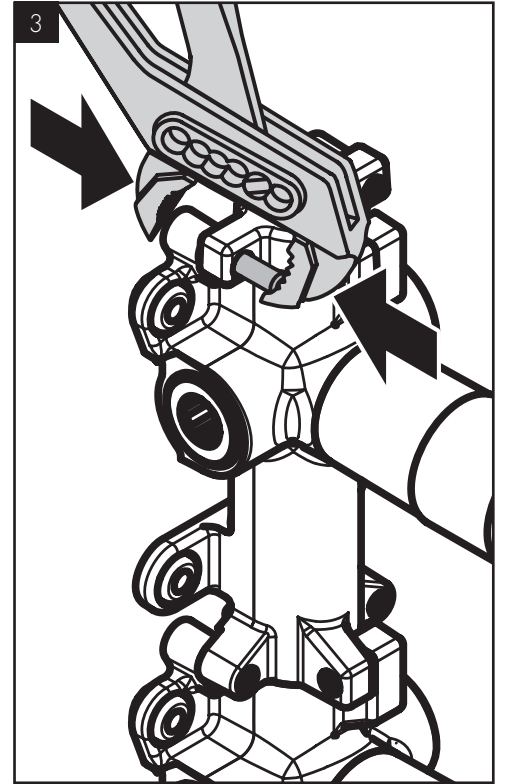
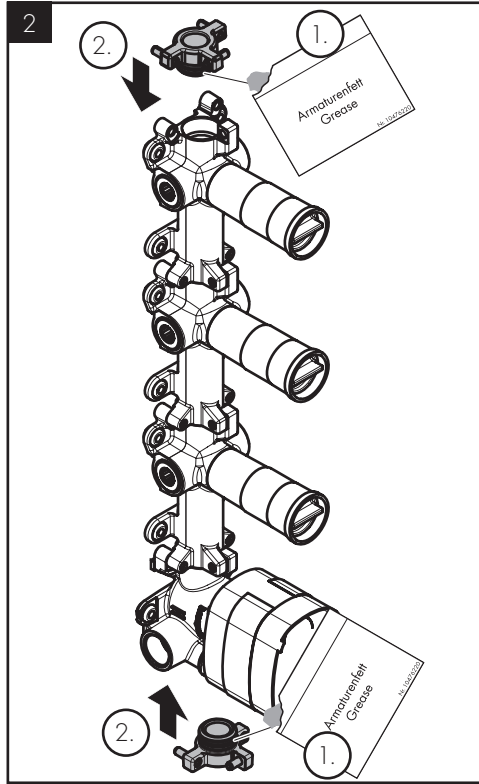
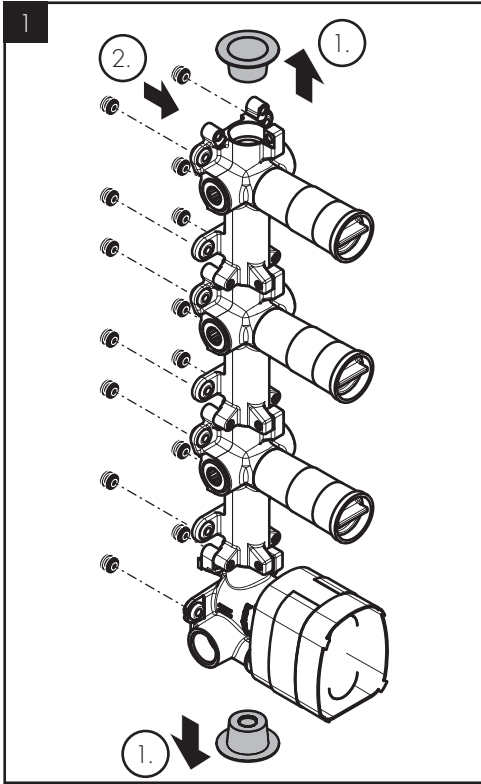

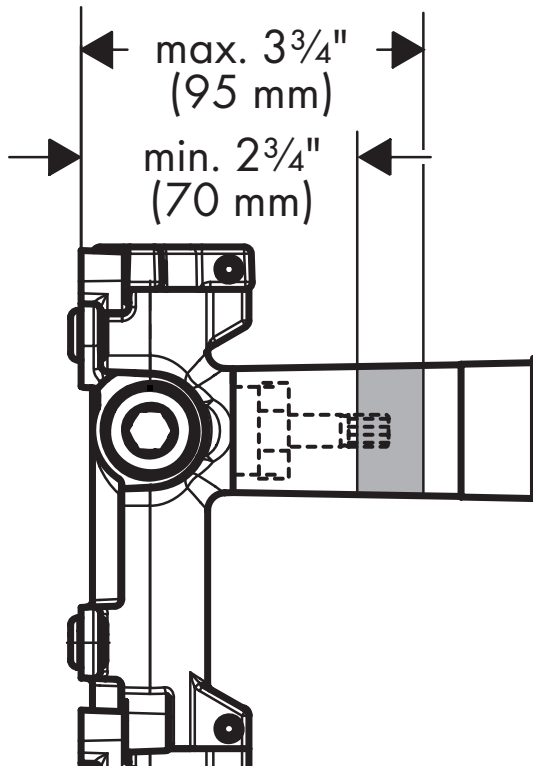
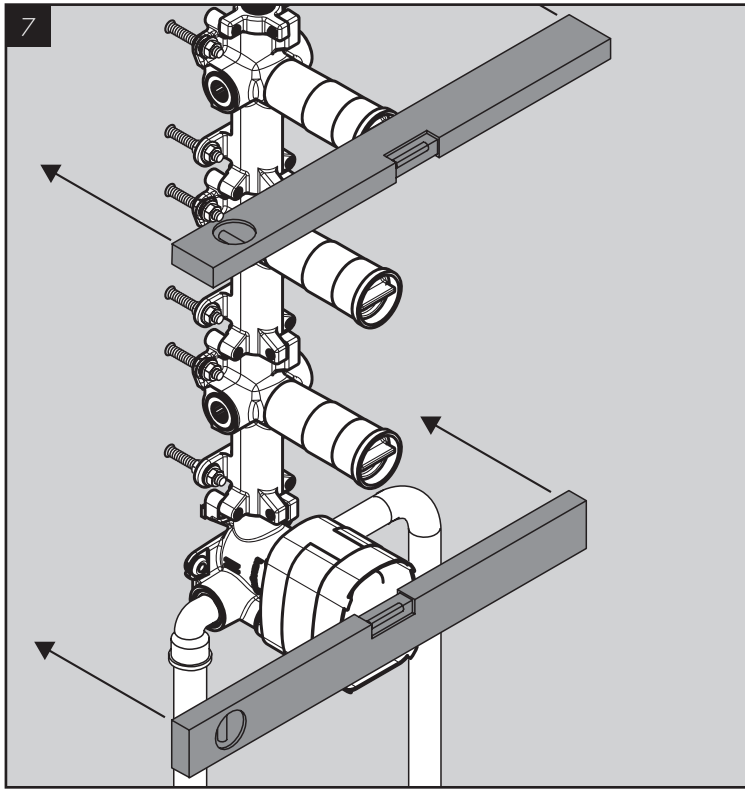

△ The outside surface of the finished wall must fall between the "min" and "max" markings on the plaster shields.

△ Installez le robinet de façon à ce que la surface extérieure du mur fini se trouve entre les lignes « minimum » et « maximum ».

△ Instale la válvula de modo que la superficie exterior de la pared terminada quede entre las marcas "min" y "max".

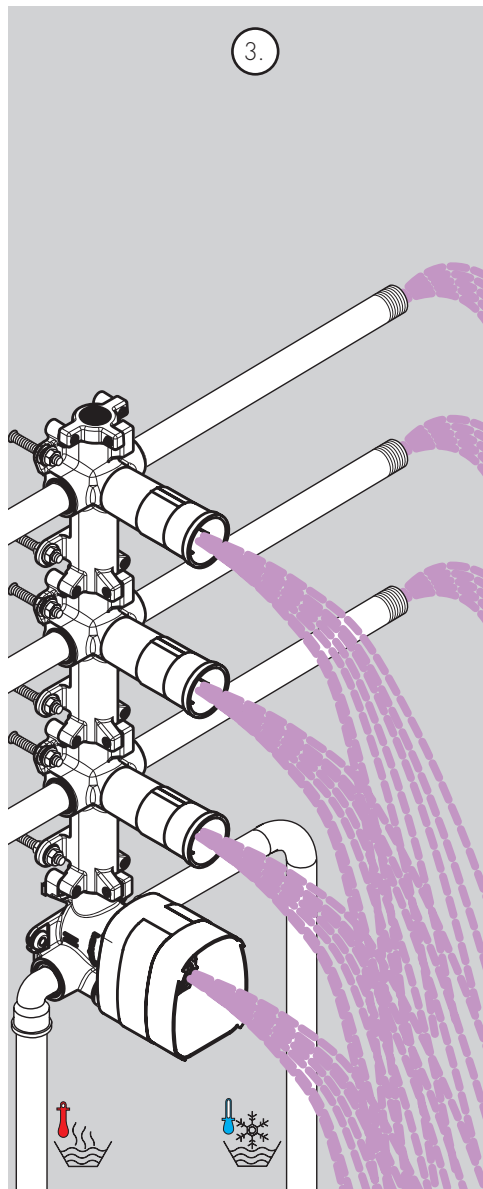
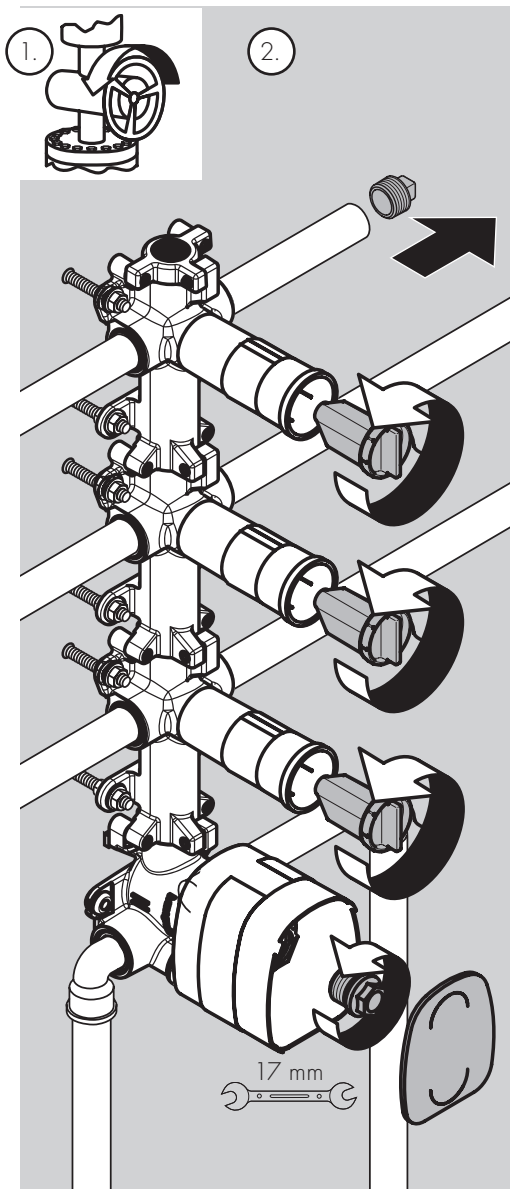

⚠ Use caution with skin contact to hot water to reduce the risk of scald injury.

⚠ Faites attention lorsque la peau entre en contact avec l'eau chaude afin de réduire le risque de brûlure.

⚠ Tenga cuidado con el contacto de la piel con agua caliente para reducir el riesgo de sufrir quemaduras.

INSTALL THE FINISHED WALL / INSTALLEZ LE MUR FINI / INSTALE LA PARED TERMINADA

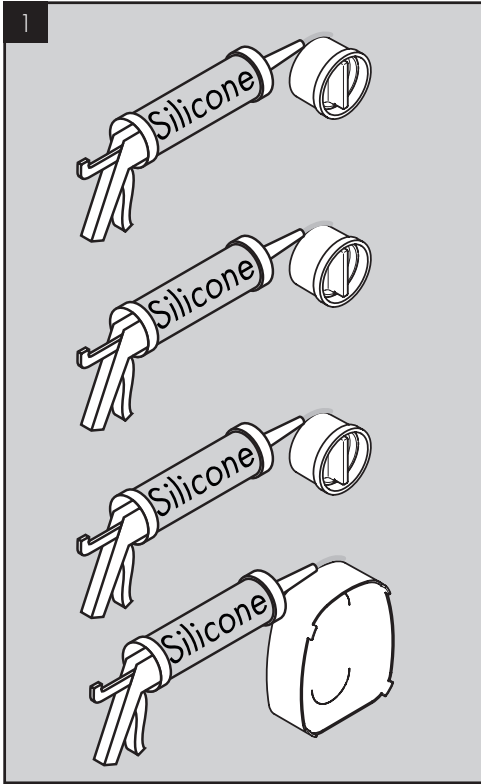

Install sheet rock or backer board over the valves.

Seal the wall around the plaster shields using waterproof sealant.

Installez le panneau d'appui pour carrelage. Il doit atteindre les valves.

Scellez le mur autour de les valves à l'aide d'un agent d'étanchéité.

Instale el tablero de soporte de los azulejos. Debe llegar hasta la caja de instalación iBox.

Selle la pared alrededor de las válvulas con un sellador impermeable.

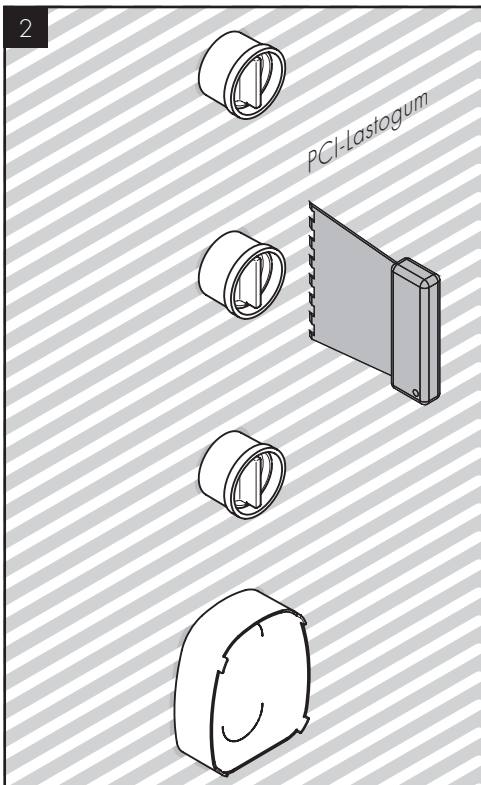

Brush adhesive (not included) over the backer board.

⚠ Do not use hot glue.

Appliquez un adhésif à l'épreuve de l'eau (non inclus) sur le panneau d'appui, autour de les valves.

⚠ N'utilisez pas de colle chaude car vous pourriez endommager le joint.

Aplique adhesivo (no incluido) a la pared alrededor de las válvulas.

⚠ No use cola caliente, puesto que daña la junta.

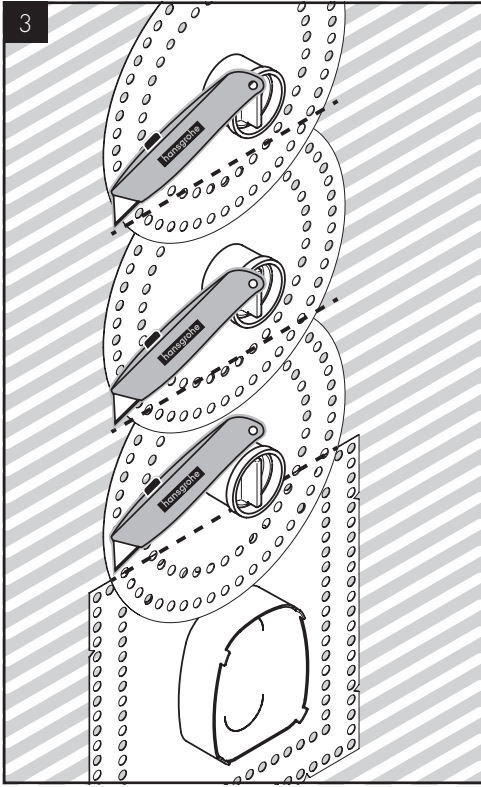

Install the sealing gasket(s).

Cut the sealing gasket to size.

⚠ Do not allow the gaskets to overlap.

Installez le joint.

Couper les joints à la taille voulue.

⚠ Les joints ne doivent pas se chevaucher.

Instale la junta.

Cortar la junta de estanqueidad.

⚠ No deben sobreponerse las juntas de estanqueidad.

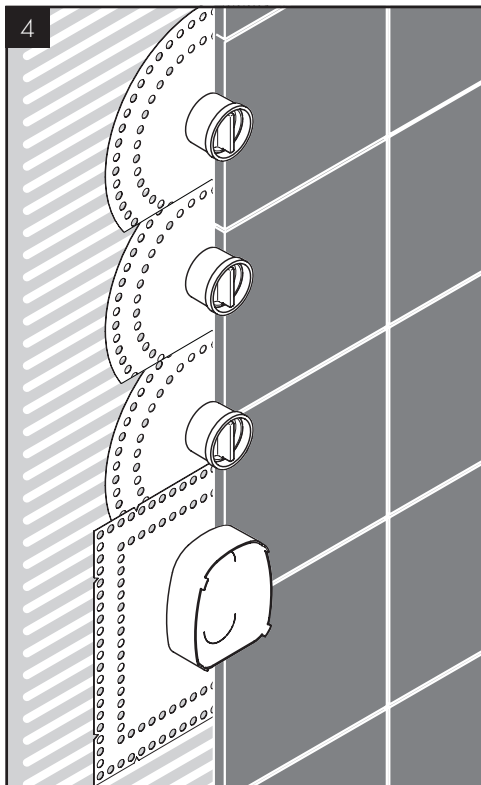

Install the tile or other finished wall material over the sealing gasket.

Installez les carreaux sur le joint.

Instale el azulejo sobre la junta.

AXOR One
48710181

AXOR One
48720181

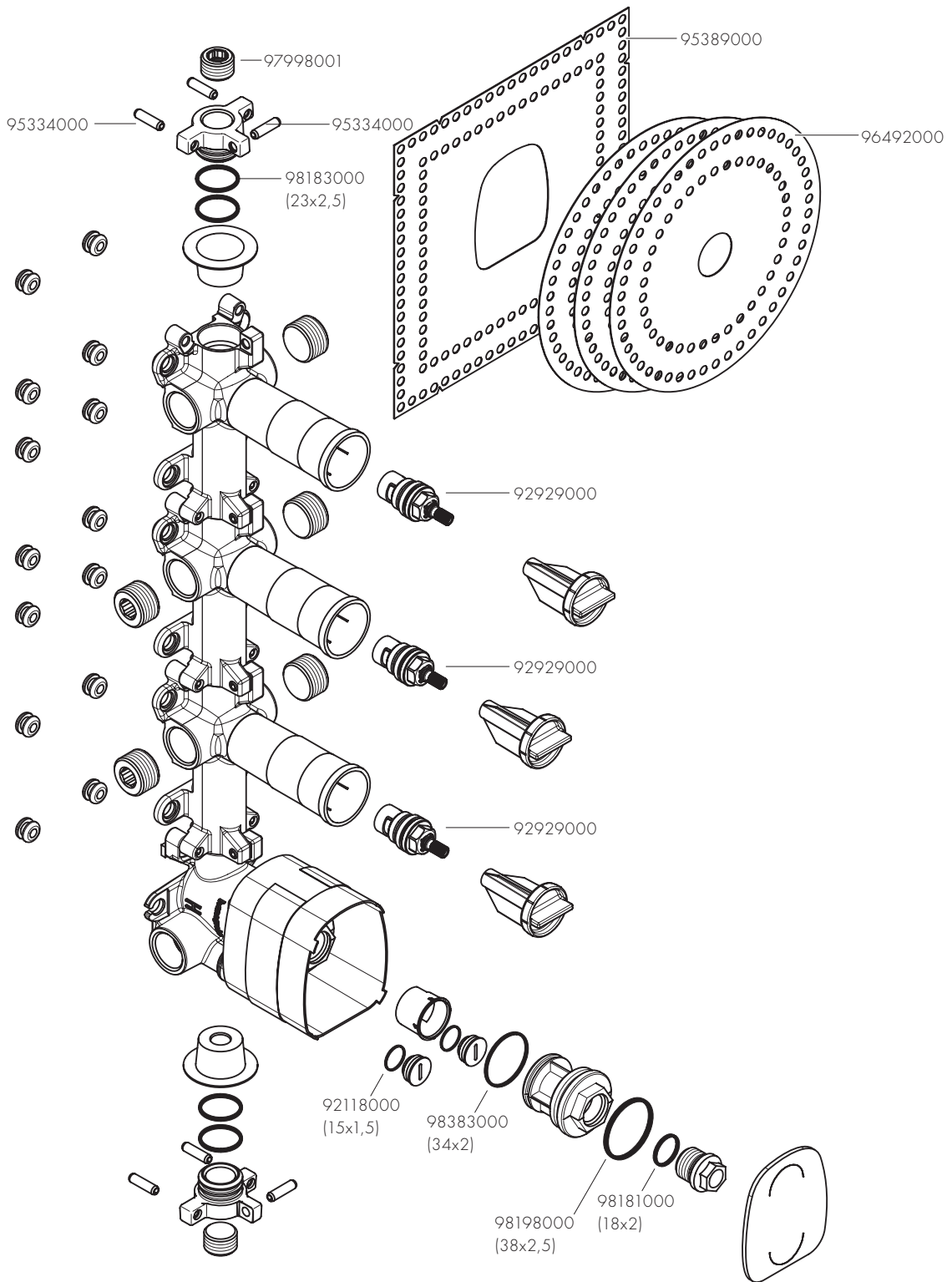



HANSGROHE, INC. LIMITED WARRANTY

Offering our customers the highest quality at all times is a fundamental part of the Hansgrohe, Inc. company philosophy. We offer consumers a limited warranty on our hansgrohe® and AXOR® branded products.

This warranty is limited to products manufactured by Hansgrohe, Inc. that are purchased from a Hansgrohe, Inc. authorized seller by a consumer in the United States or Canada after September 1, 2019, and installed in either the United States or in Canada.

WARRANTY

Hansgrohe, Inc. warrants to the original consumer purchaser that hansgrohe and AXOR products will be free from defects in material and workmanship for as long as the original consumer purchaser owns both the product and the home in which the product was originally installed. For commercial purchasers, the warranty period is (a) one (1) year for hansgrohe products and (b) five (5) years for AXOR products, in each case from the date of purchase. The warranty period for products in the Rubbed Bronze, Matte Black and Matte White finishes are three (3) years from the date of purchase. This warranty is non-transferable.

WHAT WE WILL DO

Hansgrohe, Inc., at its option, will replace any product or part of the product that proves defective in workmanship and/or material, under normal installation, use, service and maintenance. If Hansgrohe, Inc. is unable to provide a replacement part or product and repair is not practical or cannot be made in timely fashion, Hansgrohe, Inc. may elect to refund the purchase price in exchange for the return of the defective product. REPAIR OR REPLACEMENT (OR, IN LIMITED CIRCUMSTANCES, REFUND OF THE PURCHASE PRICE) AS PROVIDED UNDER THIS LIMITED WARRANTY IS THE EXCLUSIVE REMEDY OF THE PURCHASER.

WHAT IS NOT COVERED BY THE WARRANTY

Because Hansgrohe, Inc. is unable to control the quality of hansgrohe or AXOR products sold by unauthorized sellers, unless otherwise prohibited by law, this warranty does not cover hansgrohe or AXOR products purchased from unauthorized sellers. Authorized sellers can be found on hansgrohe and AXOR branded websites.

Labor and other expenses for disconnection, deinstallation, or return of the product for warranty service (including but not limited to proper packaging and shipping costs), or for installation or reinstallation of the product are not covered by this warranty.

Hansgrohe, Inc. shall not be liable for any damage to the product resulting from

- reasonable wear and tear
- outdoor use
- misuse (including use of the product for an unintended application)
- freezing water
- excessive water pressure
- pipe corrosion in the home in which the product is installed
- abuse, neglect or improper or incorrectly performed installation, maintenance or repair, including the use of abrasive or caustic cleaning agents or "no-rinse" cleaning products.

This warranty does not cover: (i) accessories, connected materials and products, or related products not manufactured by Hansgrohe, Inc. (ii) any hansgrohe or AXOR product sold for display purposes or (iii) hansgrohe or AXOR products purchased from unauthorized sellers.

WHAT YOU MUST DO TO OBTAIN WARRANTY SERVICE OR INFORMATION

Contact your retailer, or contact Technical Service at:

Hansgrohe, Inc.
1492 Bluegrass Lakes Parkway
Alpharetta, GA 30004
Toll-free 800-334-0455

In requesting warranty service, you will need to provide:

1. The sales receipt or other evidence of the date and place of purchase.
2. A description of the problem.
3. Delivery of the product or the defective part, postage prepaid and carefully packed and insured, to:

Hansgrohe, Inc.
1492 Bluegrass Lakes Parkway
Alpharetta, GA 30004
Toll-free 800-334-0455

When warranty service is completed, any repaired or replacement product or part will be returned to you postage prepaid.

REVISED SEPTEMBER 1, 2019.

LIMITATION ON DURATION OF IMPLIED WARRANTIES: Some States do not allow limitations on how long an implied warranty lasts, so the below

limitations may not apply to you. TO THE MAXIMUM EXTENT PERMITTED BY APPLICABLE LAW, ANY IMPLIED WARRANTY, INCLUDING THE IMPLIED WARRANTIES OF MERCHANTABILITY AND OF FITNESS FOR A PARTICULAR PURPOSE, IS LIMITED TO THE STATUTORY PERIOD OR THE DURATION OF THIS WARRANTY, WHICHEVER IS SHORTER.

LIMITATION OF SPECIAL, INCIDENTAL OR CONSEQUENTIAL DAMAGES: Some States do not allow the exclusion or limitation of incidental or consequential damages, so the below limitations and exclusions may not apply to you. TO THE MAXIMUM EXTENT PERMITTED BY APPLICABLE LAW, THIS WARRANTY DOES NOT COVER, AND HANSGROHE, INC. SHALL NOT BE LIABLE FOR, ANY SPECIAL, INCIDENTAL OR CONSEQUENTIAL DAMAGES (INCLUDING LABOR CHARGES TO REPAIR, REPLACE, INSTALL OR REMOVE THIS PRODUCT), WHETHER ARISING OUT OF BREACH OF ANY EXPRESS OR IMPLIED WARRANTY, BREACH OF CONTRACT, TORT, OR OTHERWISE. HANSGROHE, INC. SHALL NOT BE LIABLE FOR ANY DAMAGE TO THE PRODUCT RESULTING FROM REASONABLE WEAR AND TEAR, OUTDOOR USE, MISUSE (INCLUDING USE OF THE PRODUCT FOR AN UNINTENDED APPLICATION), FREEZING WATER, EXCESSIVE WATER PRESSURE, PIPE CORROSION IN THE HOME IN WHICH THE PRODUCT IS INSTALLED, ABUSE, NEGLIGENCE OR IMPROPER OR INCORRECTLY PERFORMED INSTALLATION, MAINTENANCE OR REPAIR, INCLUDING THE USE OF ABRASIVE OR CAUSTIC CLEANING AGENTS OR "NO-RINSE" CLEANING PRODUCTS.

NOTICE TO RESIDENTS OF THE STATE OF NEW JERSEY: The provisions of this warranty, including its limitations, are intended to apply to the fullest extent permitted by the laws of the State of New Jersey.

This warranty gives you specific legal rights, and you may also have other rights which vary from state to state.

PRODUCT INSTRUCTIONS AND QUESTIONS

Upon purchase or prior to installation, please carefully inspect your product for any damage or visible defect. Prior to installing, always carefully study the enclosed instructions on the proper installation and the care and maintenance of this product.

If you have questions at any time about the use, installation or performance of your product, or the Limited Warranty, please write us or call us toll-free at 800-334-0455.

AXOR / Hansgrohe, Inc.
1490 Bluegrass Lakes Parkway
Alpharetta, GA 30004
Tel. 800-334-0455
Fax 770-889-1783

axor-design.com