

# AXOR®

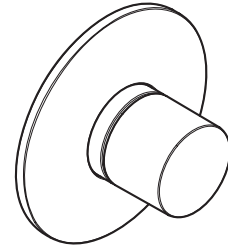

AXOR One™  
48712XX1

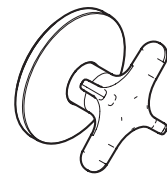
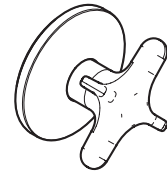
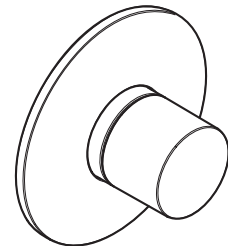

AXOR One™  
48722XX1

EN Installation / User Instructions / Warranty  
FR Instructions de montage / Mode d'emploi / Garantie  
ES Instrucciones de montaje / Manejo / Garantía

## INSTALLATION

# ENGLISH

## SAFETY NOTES

- ⚠ **WARNING:** To avoid the risk of product failure, property damage, and personal injury, do the following:
- ⚠ This product should be installed by a licensed professional plumber.
- ⚠ This product is for use with drinking water only.
- ⚠ Prevent the buildup of mineral scale and /or soap residue by cleaning your Hansgrohe product(s) when needed.
- ⚠ Refer to the Cleaning Recommendations on page 14 when selecting a cleaning agent for this product. Do not use cleaning products containing chlorine bleach, lye, hydrochloric acid, formic acid, acetic acid, or abrasives.
- ⚠ Failure to follow these instructions may result in product failure and property damage, and may void the warranty.

## INSTALLATION CONSIDERATIONS

- / Read over these instructions thoroughly before beginning installation. Make sure that you have all tools and supplies needed to complete the installation.
- / This trim is for use with rough valve 48720181 (not included). When this trim kit is installed on the rough valve, an automatically compensating valve for anti-scald protection for individual fixture fittings, compliant to ASME A112.18.1/CSA B125.1, will be created.
- ⚠ **DO NOT USE A DIVERTER TUB SPOUT!**
- ⚠ **IMPORTANT:** This product includes a device to reduce the total simultaneous flow of water in the shower to 1.75 GPM (6.6 l/min) @ 80 PSI (0.55 MPa) as required by some plumbing codes. The device is not pre-installed. See the instructions on page 7.
- / When the flow control accessory is installed, this valve cannot be used as a tub filler.
- / To prevent scald injury, the maximum output temperature of the shower valve must be no higher than 120°F (49° C). In Massachusetts, the maximum output temperature can be no higher than 112°F (44° C).
- / This product is for use with shower heads rated at 1.1 GPM (4.2 L/min) or higher.
- / Keep this booklet and the receipt (or other proof of date and place of purchase) for this product in a safe place. The receipt is required should it be necessary to request warranty parts.

## TECHNICAL INFORMATION

Water pressure	
Recommended	15 - 75 PSI (0.1 - 0.5 MPa)
Maximum	145 PSI (1 MPa)
Hot water temp.	
Recommended	120°-140° F (48° - 60° C)*
Maximum	158°F (70° C)*
Max. flow rate @ 60 PSI (0.4 MPa)	8.5 GPM (32.2 L/min)
Max. flow rate** @ 80 PSI (0.55 MPa)	1.75 GPM (6.6 l/min)
* Please know and follow all applicable local plumbing codes when setting the temperature on the water heater.	
** After modification using the included flow control device.	

# FRANÇAIS

## CONSIGNES DE SÉCURITÉ

- ⚠ **AVERTISSEMENT :** Afin d'éviter les risques de défaillance du produit, de dommages matériels et de blessures corporelles, veuillez procéder de la manière suivante :
- ⚠ Ce produit devrait être installé par un plombier professionnel certifié.
- ⚠ Ce produit doit être utilisé avec de l'eau potable seulement.
- ⚠ Évitez l'accumulation de tartre minéral ou de résidus de savon en nettoyant vos produits Hansgrohe lorsque cela est nécessaire.
- ⚠ Reportez-vous aux recommandations pour le nettoyage à la page 14 au moment de sélectionner un agent de nettoyage pour ce produit. N'utilisez pas de produits de nettoyage contenant du chlore, du javellisant au chlore, de l'acide chlorhydrique, de l'acide formique, de l'acide acétique ou des abrasifs.
- ⚠ Le non-respect de ces instructions peut entraîner une défaillance du produit et des dommages matériels, ainsi que l'annulation de la garantie.

## À PRENDRE EN CONSIDÉRATION POUR L'INSTALLATION

- / Veuillez lire attentivement ces instructions avant de procéder à l'installation. Assurez-vous de disposer de tous les outils et du matériel nécessaires pour l'installation.
- / Ce dispositif requiert une pièce intérieure 48720181 (non compris). Une valve de compensation automatique pour protection anti-brûlure de raccords de robinetterie individuels, conforme à la norme ASME A112.18.1/CSA B125.1, est obtenue lorsque l'ensemble de garniture est installé.
- ⚠ **N'UTILISEZ PAS UNE BEC DE BAIGNOIRE INVERSEUR!**
- ⚠ **IMPORTANT:** Ce produit comprend un dispositif pour réduire le débit d'eau total simultané dans la douche à 1.75 gal/mn (6.6 l/mn) à 80 psi (0.55 MPa), comme l'exigent certains codes de plomberie. Le dispositif n'est pas préinstallé. Voir page 7.
- / Lorsque le limiteur de débit est installé, cette vanne ne peut pas être utilisée comme remplisseur de baignoire.
- / Pour empêcher des blessures par ébullition, la température de sortie maximale du robinet de douche ne doit pas excéder 120°F (49° C). Au Massachusetts, la température de sortie maximale du robinet de douche ne doit pas excéder 112°F (44° C).
- / Ce produit devrait être seulement utilisé avec les pommes de douche évaluées à 1.1 GPM (4.2 L/min) ou plus.

- / Conservez ce livret et le reçu (ou une autre preuve sur laquelle figurent la date et l'endroit de l'achat) pour ce produit dans un endroit sûr. Le reçu est requis si vous commandez des pièces sous garantie.

## DONNÉES TECHNIQUES

Pression d'eau recommandée	15 - 75 PSI (0.1 - 0.5 MPa)
maximum	145 PSI (1 MPa)
Température d'eau chaude recommandée	120°-140° F (48° - 60° C)*
maximum	158°F (70° C)*
Capacité nominale @60 PSI (0.4 MPa)	8.5 GPM (32.2 L/min)
Capacité nominale** @ 80 PSI (0.55 MPa)	1.75 GPM (6.6 l/min)
* Vous devez connaître et respecter tous les codes de plomberie locaux applicables pour le réglage de la température du chauffe-eau.	
** Après modification avec le dispositif de contrôle de débit inclus.	

# ESPAÑOL

## INDICACIONES DE SEGURIDAD

- ⚠ **ADVERTENCIA:** Para evitar el riesgo de falla del producto, daño a la propiedad y lesiones personales, haga lo siguiente:
- ⚠ Este producto debe ser instalado por un plomero profesional matriculado.
- ⚠ Este producto ha sido creado para su uso exclusivo con agua potable.
- ⚠ Consulte las Recomendaciones de Limpieza en la página 14 para seleccionar un agente de limpieza para este producto. No use productos de limpieza que contengan blanqueador con cloro, lejía, ácido clorhídrico, ácido fórmico, ácido acético o abrasivos.
- ⚠ No seguir estas instrucciones puede resultar en la falla del producto y daño de la propiedad, y puede anular la garantía.

## CONSIDERACIONES PARA LA INSTALACIÓN

- / Antes de comenzar la instalación, lea estas instrucciones detenidamente. Asegúrese de tener las herramientas y los insumos necesarios para completar la instalación.
- / La unidad requiere una pieza interior de válvula 48720181 (no incluida). Cuando se instala el kit de pieza exterior se crea una válvula de compensación automática para protección anti-escaldadura para accesorios individuales, en cumplimiento con ASME A112.18.1/CSA B125.1.
- ⚠ **¡NO USE UN SURTIDOR DE BAÑERA TIPO DISTRIBUIDOR!**
- ⚠ **¡IMPORTANTE:** Este producto incluye un dispositivo para reducir el flujo total simultáneo de agua en la ducha a 1.75 GPM (6.6 l/min) a 80 PSI (0.55 MPa), según lo requerido por algunos códigos de plomería. El dispositivo no está preinstalado. Vea la página 7.
- / Cuando se instala el limitador de caudal, esta válvula no se puede utilizar para llenar una bañera.
- / Para evitar escaldaduras, la máxima temperatura de salida de la válvula de la ducha no debe exceder los 120°F (49° C). En Massachusetts, la máxima temperatura de salida de la válvula de la ducha no debe exceder los 112°F (44° C).

- / Este producto debe ser utilizado sólo con alcachofas de la ducha valoradas en 1.1 GPM (4.2 L/min) o más.
- / Mantenga este folleto y el recibo (u otro comprobante del lugar y fecha de compra) de este producto en lugar seguro. El recibo se requiere en caso de ser necesario solicitar piezas bajo garantía.

## DATOS TECNICOS

Presión en servicio	
recomendada	15 - 75 PSI (0.1 - 0.5 MPa)
max.	145 PSI (1 MPa)
Temperatura del agua caliente	
recomendada	120°-140° F (48° - 60° C)*
max.	158°F (70° C)*
Caudal máximo	8.5 GPM (32.2 L/min)
@ 60 PSI (0.4 MPa)	
Caudal máximo**	1.75 GPM (6.6 l/min)
@ 80 PSI (0.55 MPa)	
*	Debe conocer y cumplir todos los códigos locales aplicables para ajustar la temperatura del calentador de agua.
**	Después de la modificación con el dispositivo de control de flujo incluido.

AXOR One  
48722XX1

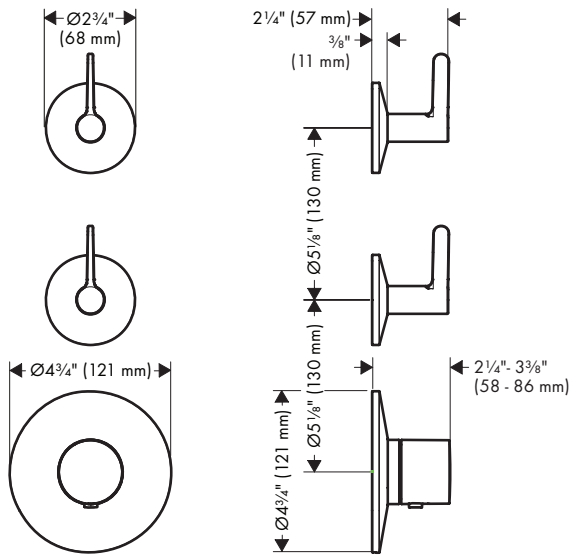

AXOR One  
48712XX1

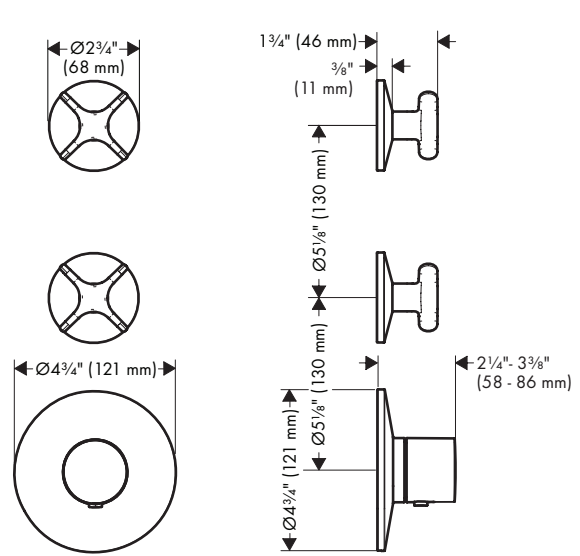

TOOLS REQUIRED / OUTILS REQUIS  
/ HERRAMIENTAS ÚTILES

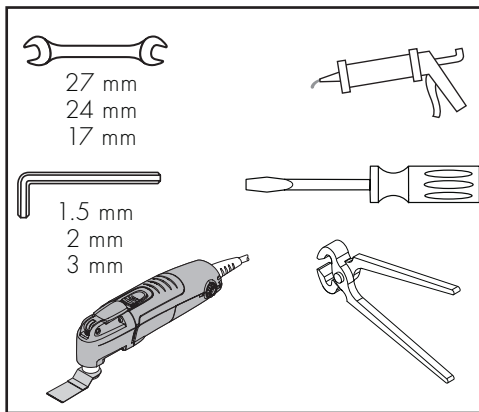

# REPLACEMENT PARTS / PIÈCES DÉTACHÉES / REPUESTOS

AXOR One  
48712XX1

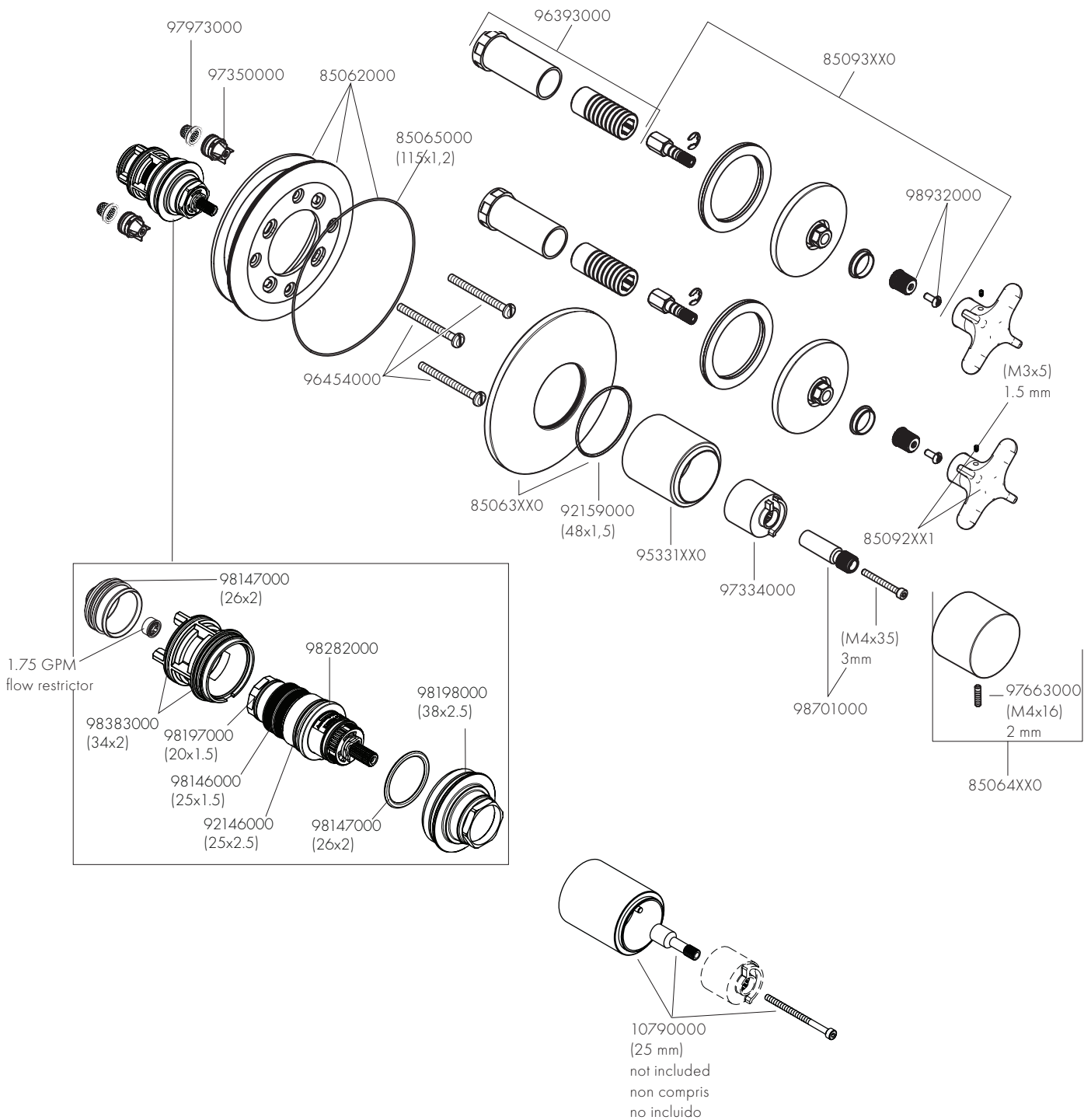

XX = COLORS / COULEURS / ACABADOS	
00 = chrome	70 = matte white
14 = brushed bronze	82 = brushed nickel
25 = brushed gold optic	83 = polished nickel
33 = polished black chrome	95 = brushed brass
34 = brushed black chrome	99 = polished gold optic
67 = matte black	

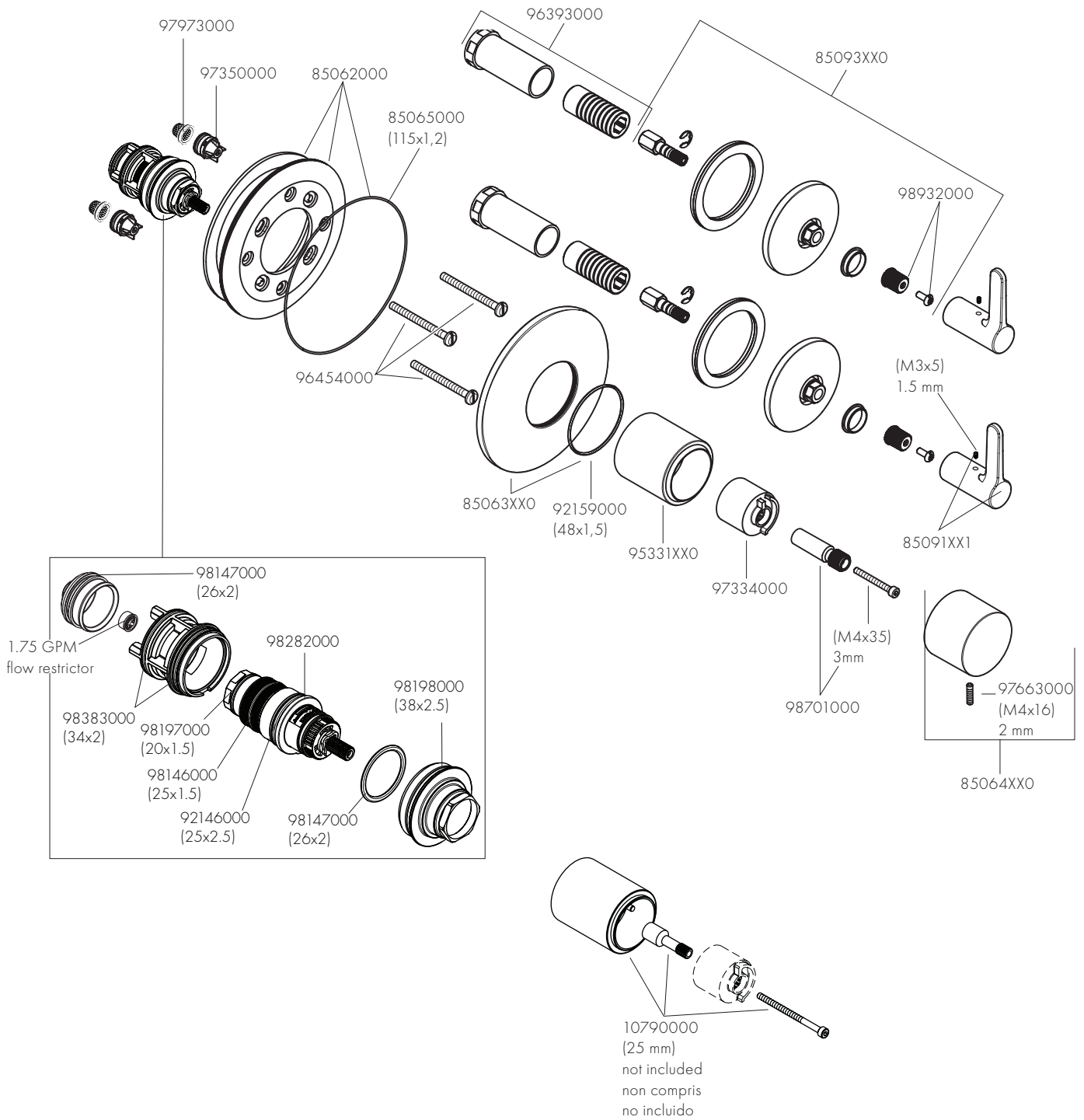

- |                                   |                          |
|-----------------------------------|--------------------------|
| XX = COLORS / COULEURS / ACABADOS |                          |
| 00 = chrome                       | 70 = matte white         |
| 14 = brushed bronze               | 82 = brushed nickel      |
| 25 = brushed gold optic           | 83 = polished nickel     |
| 33 = polished black chrome        | 95 = brushed brass       |
| 34 = brushed black chrome         | 99 = polished gold optic |
| 67 = matte black                  |                          |

# INSTALLATION / INSTALLATION / INSTALACIÓN

⚠ If your local plumbing code requires it, install the flow device to reduce the total flow of water to the maximum simultaneous flow rate of 1.75 GPM (6.6 l/min) @ 80 PSI (5.5 MPa).

⚠ Si votre code de plomberie exige, installez le dispositif de débit pour réduire le débit simultané maximal de 1.75 GPM (6.6 l/min) à 80 psi (0.55 MPa).

⚠ Si el código de plomería lo requiere, instale el dispositivo de control de flujo para reducir el flujo máximo simultáneo a 1.75 GPM (6.6 l/min) @ 80 psi (0.55 MPa).

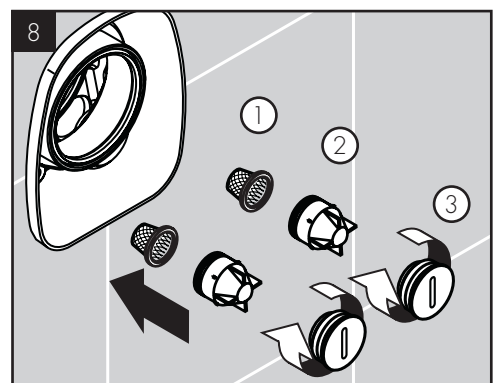
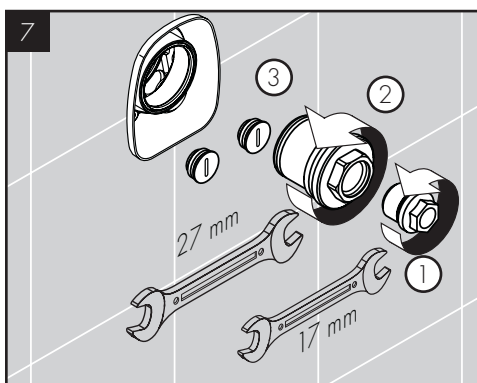
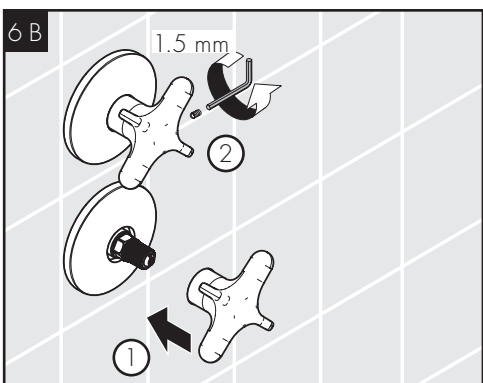
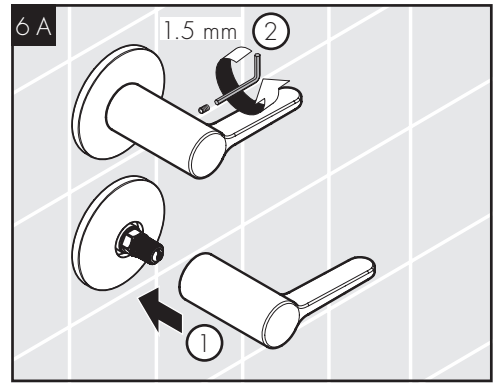
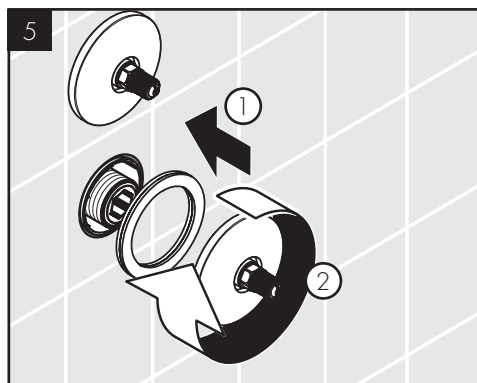
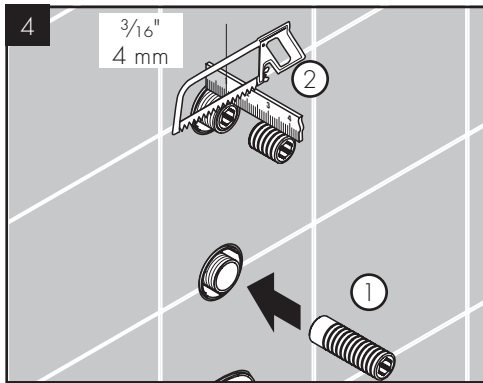
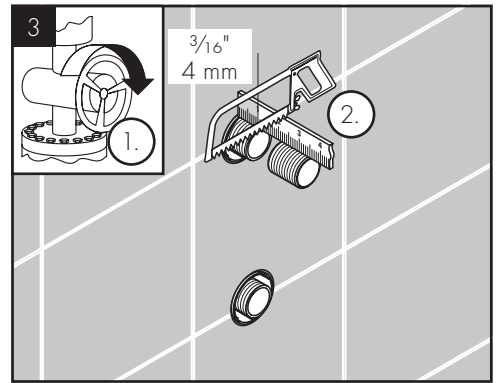
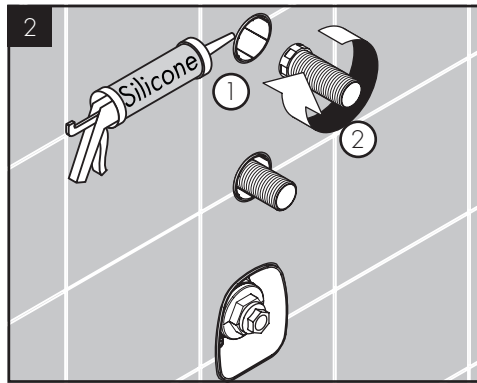
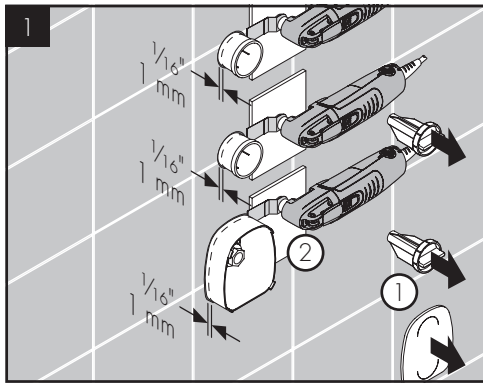
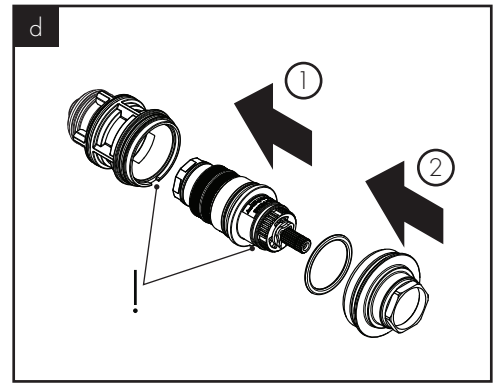
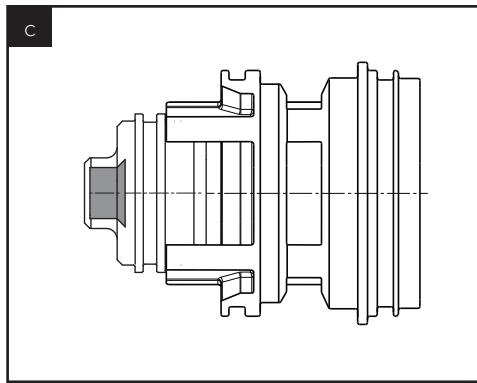
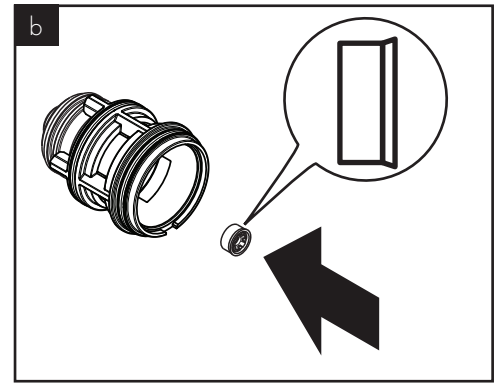
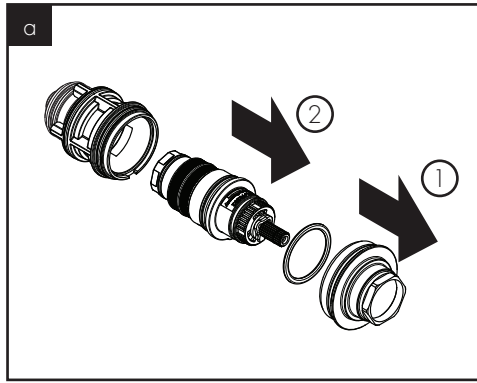

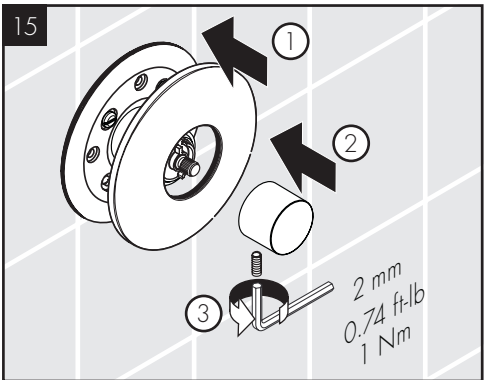
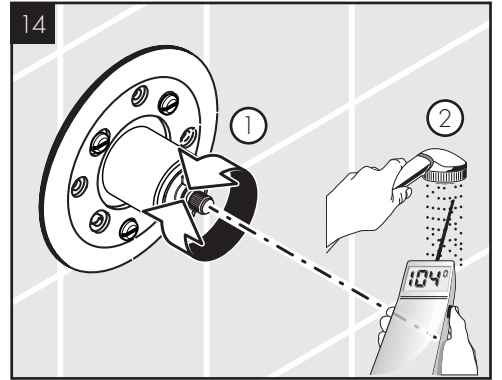
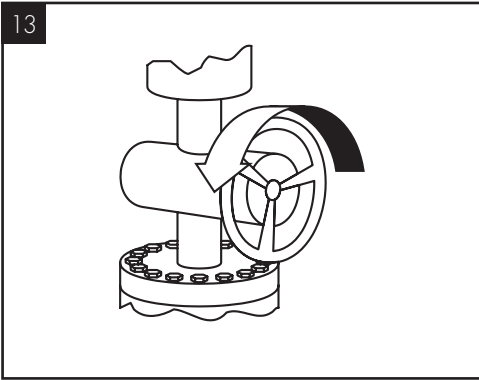
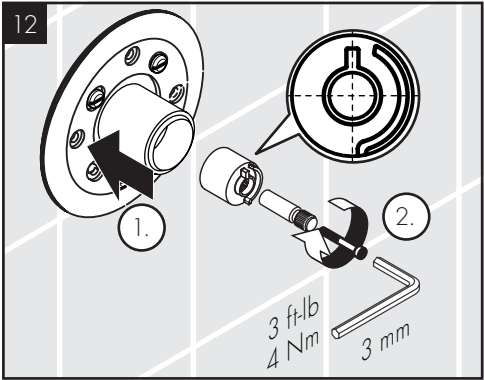
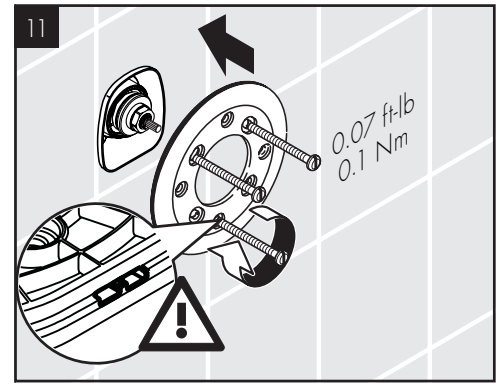
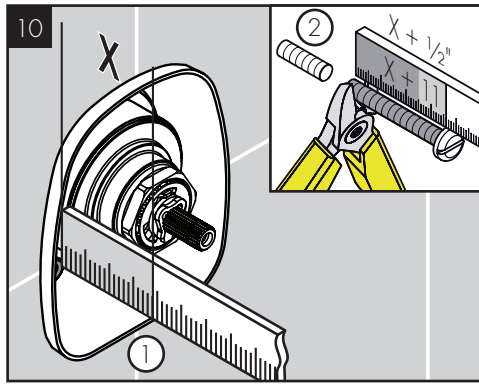
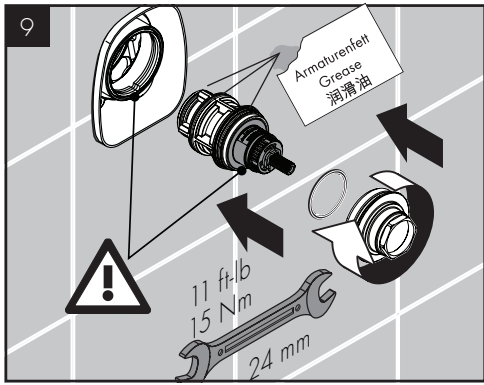

JUSTIFY THE HANDLE / RÉGLEZ LA POIGNÉE / AJUSTE LA MANIJA

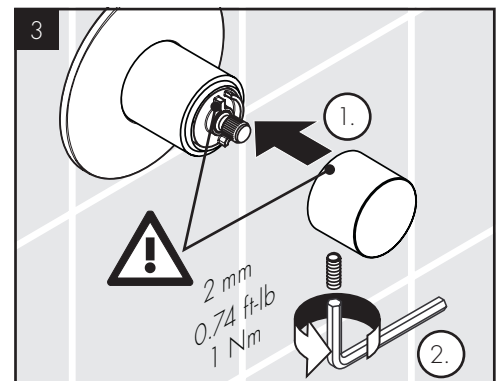
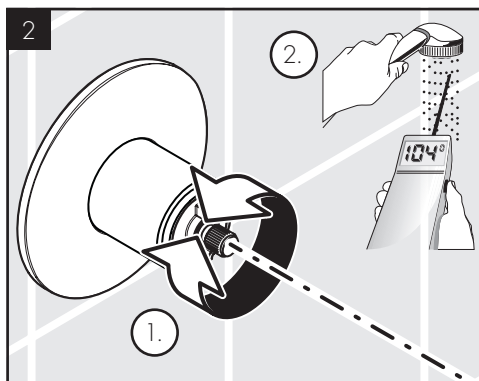
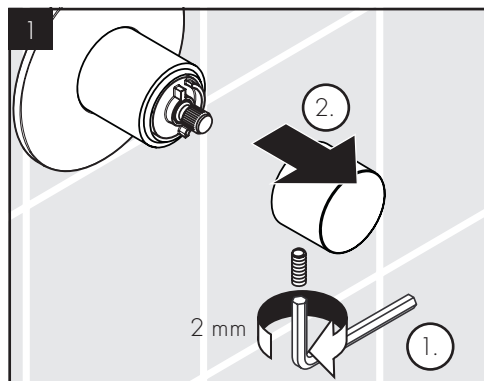

SET THE HIGH TEMPERATURE LIMIT STOP / RÉGLAGE DE LA BUTÉE LIMITE D'EAU CHAUDE / AJUSTE EL TOPE DE LÍMITE DE ALTA TEMPERATURA

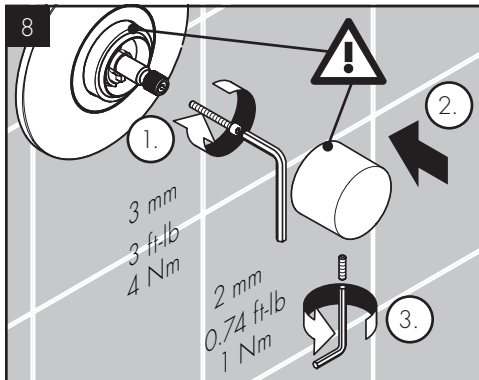
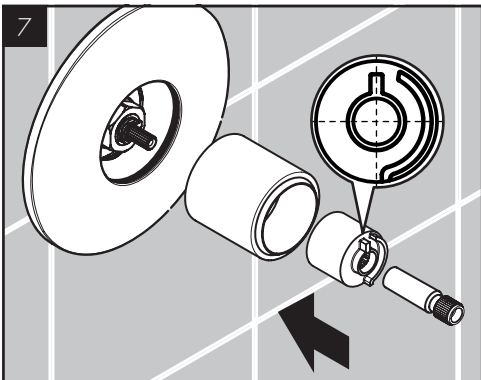
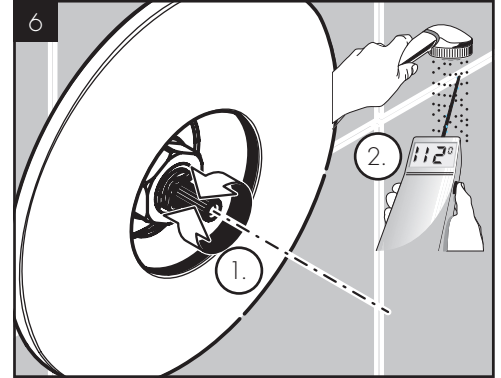
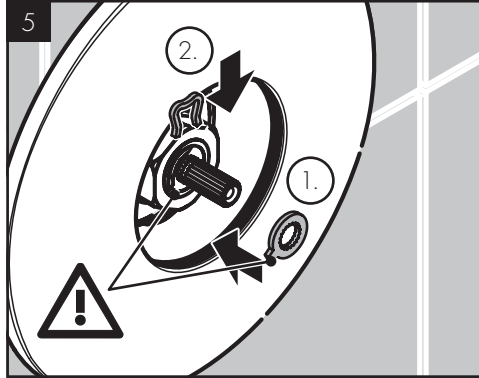
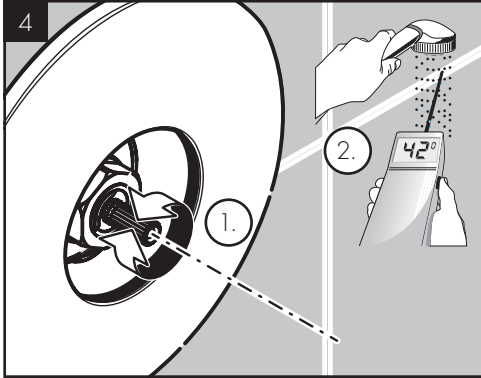
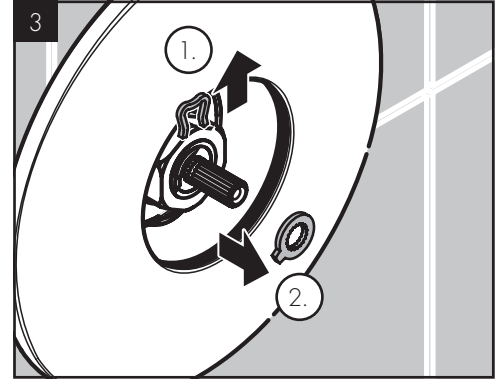
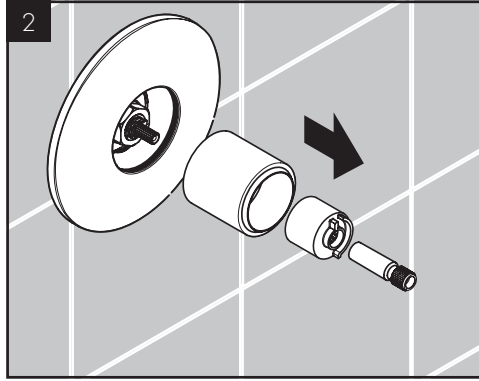
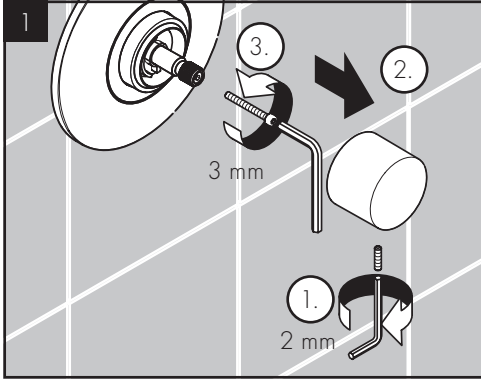

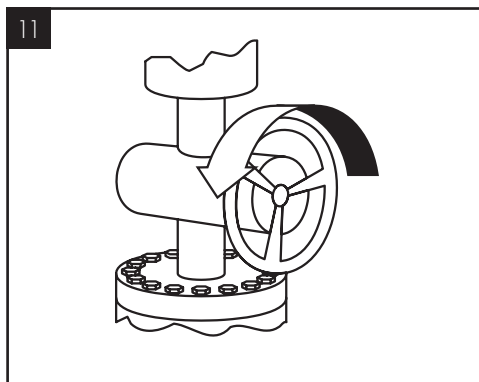
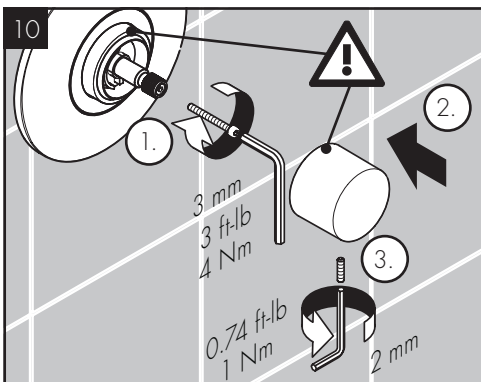
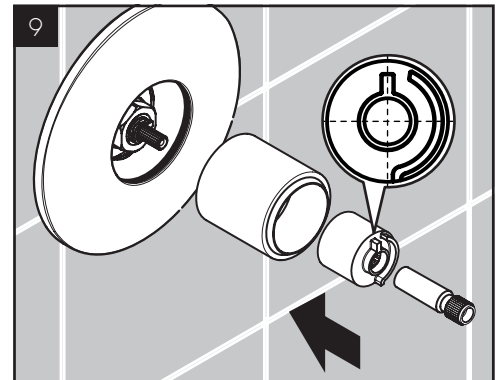
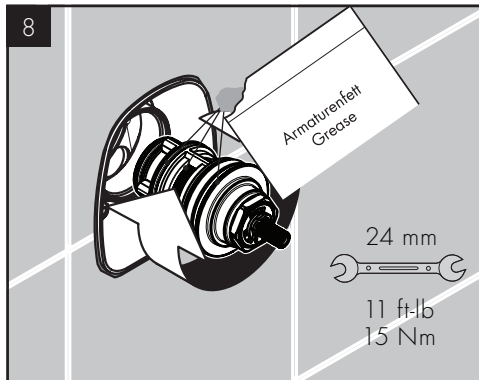
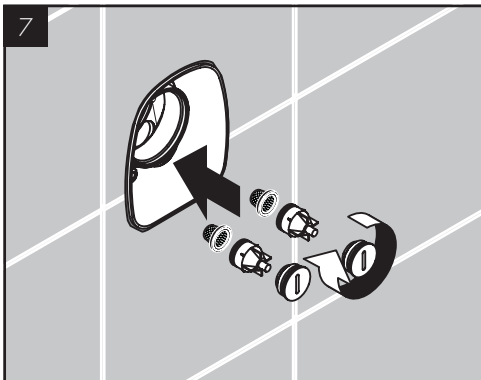
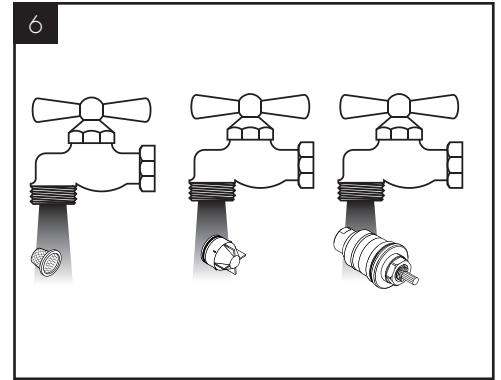
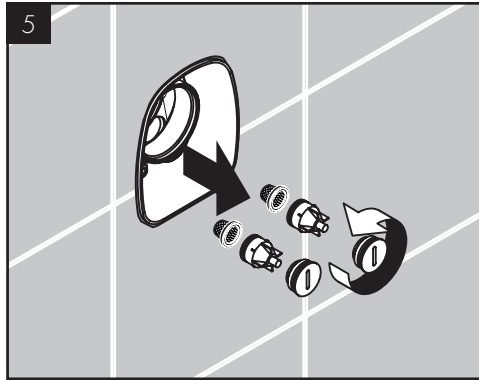
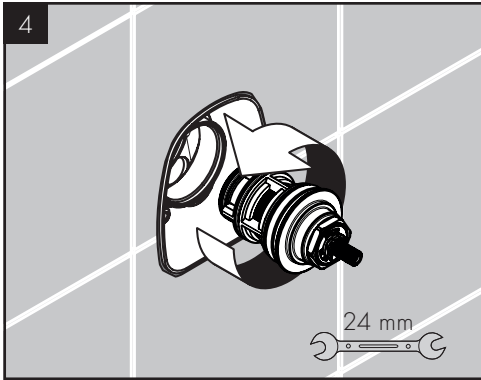
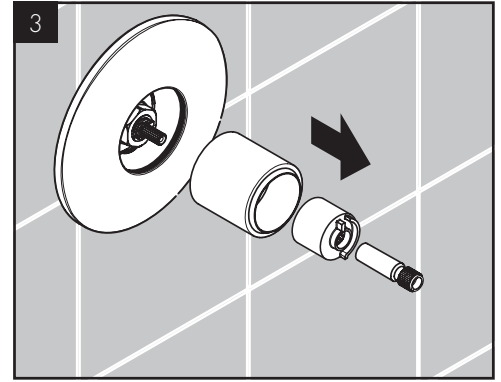
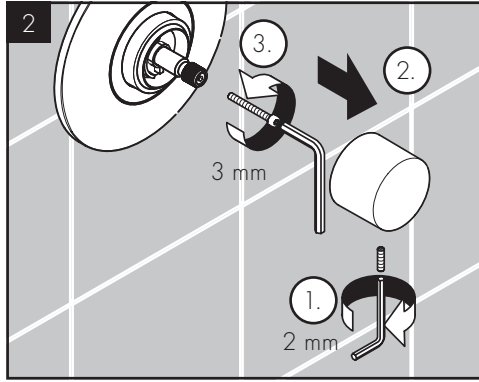
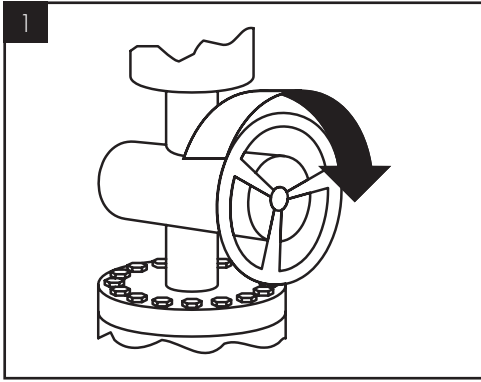

USER INSTRUCTIONS / INSTRUCCIONES DE SERVICIO / MANEJO

AXOR One  
48722XX1

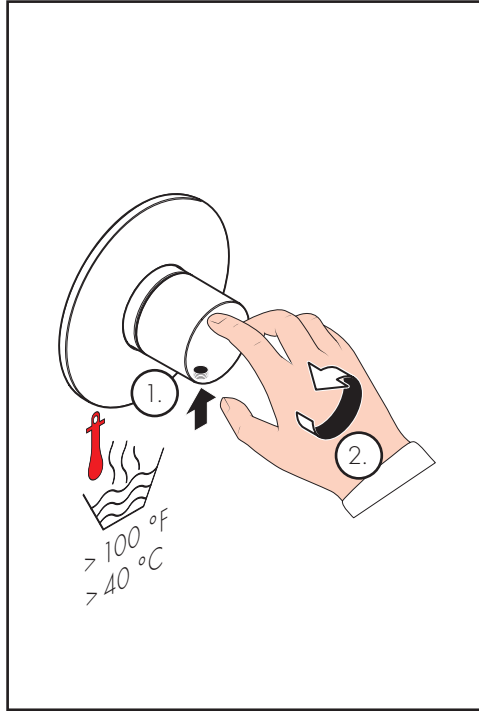
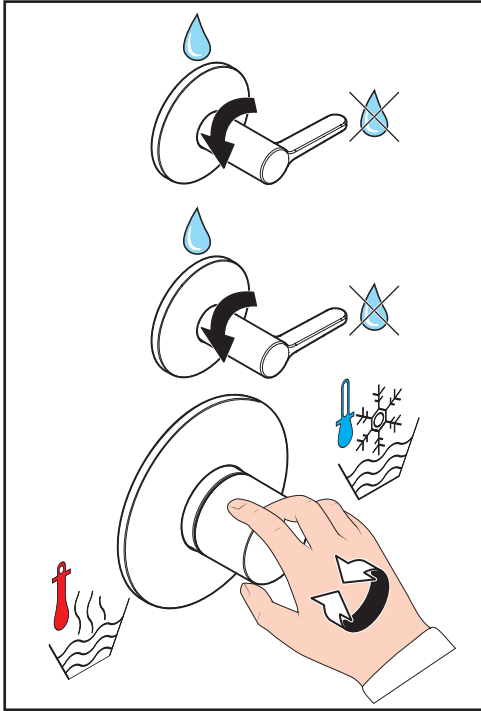

AXOR One  
48712XX1

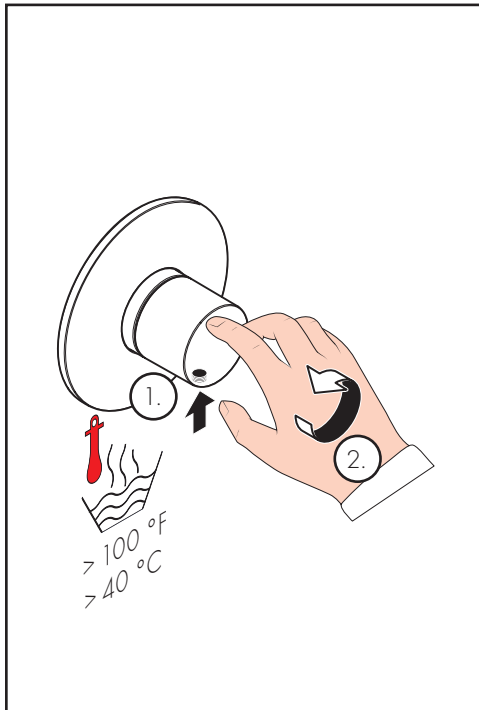
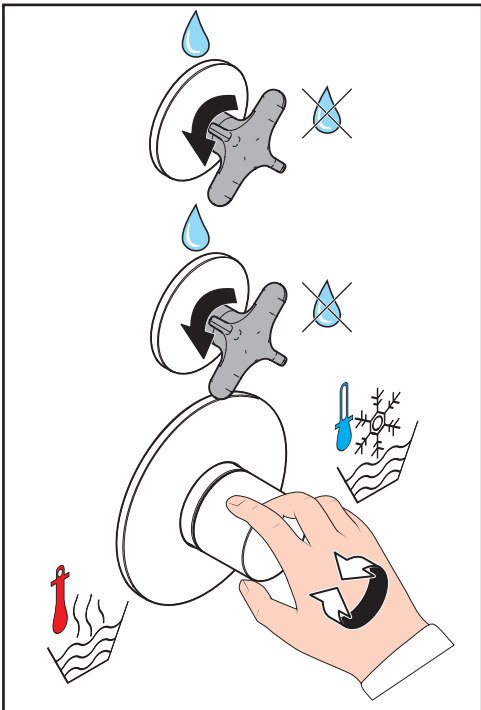

## MAINTENANCE

- / Should the volume of water decrease over time, first inspect and clean the shower-head(s). If the problem persists, inspect the cartridge.
- / To prolong the life of the thermostatic cartridge, regularly run it through its complete range of temperatures.
- / At least once per year, inspect the check valves. Replace if dirty or worn.
- △ Use caution with skin contact to hot water to reduce the risk of scald injury. Before servicing the valve, turn the water off at the main shutoff.
- / When reassembling after maintenance, set the high temperature limit stop before reinstalling the handle.
- / If the shower will not be used for an extended period of time, turn off the water to the shower valve at the main shut off.
- / If you have questions, please contact Hansgrohe Customer Service at 1-800-334-0455.

## TROUBLESHOOTING

SYMPTOM	POSSIBLE CAUSE	SUGGESTED ACTION
Insufficient water	- Supply pressure inadequate	- Check water pressure (If a pump has been installed check to see if the pump is working).
	- Thermostatic cartridge filter dirty	- Clean filters
	- Showerhead screen washer or filter gasket dirty	- Clean screen washer or filter gasket
Crossflow: hot water being forced into cold water supply, or vice versa, when mixer is closed	- Check valves dirty or worn	- Clean check valves, replace if necessary
Output temperature does not correspond with temperature set	- Handle not justified	- Justify the handle
Output temperature is erratic	- Temperature regulator dirty or calcified	- Clean temperature thermostatic cartridge filters - Replace thermostatic cartridge
Output water is all hot or all cold - doesn't mix (new installation)	- Rough valve is cross connected - hot on right and cold on left	- Correct the plumbing.
Safety stop override button not operating	- Spring defective	- Clean spring and/or button, replace if necessary
	- Button dirty	

## ENTRETIEN

- / Si le débit d'eau devait décroître avec le temps, commencez par inspecter et nettoyer la ou les pommes(s) de douche. Si le problème persiste, inspectez la cartouche.
- / Pour prolonger la durée de vie de la cartouche thermostatique, faites-la fonctionner régulièrement en utilisant toutes les températures d'eau.
- / Inspectez les clapets de non-retour au moins une fois par année. Remplacez les clapets de non-retour lorsque nécessaire.
- △ Lors de l'entretien du robinet, fermez l'eau à l'aide des butées d'arrêt à la vanne d'arrêt principale.
- / Lors du réassemblage après l'entretien, réglez la butée limite d'eau chaude avant de réinstaller la poignée.
- / Si vous ne comptez pas utiliser la douche pendant un laps de temps prolongé, fermez l'eau au robinet de douche à la vanne d'arrêt principale.
- / Si vous avez des questions, veuillez contacter le service à la clientèle de Hansgrohe au 1-800-334-0455.

## DÉPANNAGE

SYMPTÔME	CAUSE POSSIBLE	ACTION SUGGÉRÉE
Pas assez d'eau	- Pression d'alimentation insuffisante	- Contrôler la pression
	- Filtre de l'élément thermostatique encrassé	- Nettoyer les filtres
	- Joint-filtre de douchette encrassé	- Nettoyer le joint-filtre entre la douchette et le flexible
Circulation opposée, l'eau chaude est comprimée dans l'arrivée d'eau froide et vice versa avec robinet fermé	- Clapet anti-retour encrassé ou défectueux	- Nettoyer le clapet anti-retour ou le changer éventuellement
La température à la sortie ne correspond pas à la température de réglage	- Le thermostat n'a pas été réglé	- Régler le thermostat
	- Température d'eau chaude trop basse, pas d'eau froide	- Augmenter la température d'eau chaude entre 42° C et 65° C
Le réglage de la température n'est pas possible	- L'élément thermostatique est encrassé ou entartré	- Nettoyer l'élément thermostatique ou le changez éventuellement
	- La pièce de base a une alimentation inversée (l'eau froide doit être à droite et l'eau chaude à gauche) ou elle est montée à l'envers	- Corrigez la plomberie.
Bouton à pression du verrouillage de sécurité défectueux	- Ressort défectueux	- Nettoyer le ressort ou bien le bouton à pression, le changer éventuellement
	- Bouton à pression entartré	

# MANTENIMIENTO

- / Si el volumen del agua disminuye con el tiempo, primero inspeccione y limpie el cabezal de ducha. Si el problema persiste, inspeccione el cartucho.
- / Inspeccione las válvulas de retención al menos una vez por año. Reemplace las válvulas de retención de ser necesario.
- / Para prolongar la vida útil del cartucho termostático, hágalo funcionar regularmente en todos los rangos de temperatura.
- ⚠ Al realizar el mantenimiento de la válvula, corte el suministro de agua usando la válvula de paso principal.
- / Al rearmar después de realizar el mantenimiento, configure el tope de límite de alta temperatura de reinstalar la manija.
- / Si la ducha no se usará por un período extenso de tiempo, corte el suministro de agua a la válvula de la ducha usando la llave de paso principal.
- / Si tiene alguna pregunta, comuníquese con el Departamento de Asistencia al Cliente al 1-800-334-0455.

SÍNTOMA	CAUSA POSIBLE	ACCIÓN SUGERIDA
Sale poca agua	- presión insuficiente	- comprobar presión
	- filtro del termoelemento sucio	- limpiar filtro
	- filtro de la ducha sucio	- limpiar/cambiar filtros entre flexo y ducha
Flujo de agua cruzada agua caliente entra en la tubería del agua fría o al revés	- válvula antirretorno sucia o pierde	- limpiar / cambiar válvula
Temperatura del agua no corresponde a lo marcado	- termostato no ha sido ajustado	- ajustar termostato
	- temperatura del agua demasiado baja no hay	- aumentar temperatura del agua caliente a 42° - 65° C.
No es posible regular la temperatura	- termoelemento sucio/lleño de cal	- limpiar / cambiar termoelemento
	- cuerpo empotrado mal montado (debe estar: frío = derecha) o instalado girado en 180°	- corrija la plomería.
Botón de tope no funciona	- muelle defecto	- limpiar y aplicar una fina capa de grasa en el muelle y el pulsador
	- botón lleño de cal	

# CLEANING RECOMMENDATION FOR HANSGROHE PRODUCTS

Modern bathroom faucets, kitchen faucets and shower products are made from different materials to comply with the needs of the market with regard to design and functionality. To avoid damage to the product, it is necessary to take proper care of it.

## FOR BEST RESULTS:

- / Prevent the buildup of mineral scale and /or soap residue by cleaning your Hansgrohe product(s) when needed.
- / Select a cleaning agent specifically intended for the type of product.
- / DO NOT use these types of cleaners as they will cause damage to your Hansgrohe product:
  - Any cleaning agent containing chlorine bleach, lye, hydrochloric acid, formic acid, or acetic acid.
  - Abrasive cleaning powders, pads, or brushes.
  - Steam cleaners.
  - "No rinse" cleaning agents.
- / ALWAYS follow the instructions provided by the manufacturer of the cleaning agent.
- / DO NOT mix cleaning agents, unless directed by the manufacturer.
- / DO NOT spray cleaners directly onto the product as drops could enter openings and gaps and cause damage. When using spray cleaners, spray the cleaner onto a soft cloth or sponge.
- / ALWAYS rinse your Hansgrohe product thoroughly with clear water and polish dry with a soft cloth after cleaning.

## IMPORTANT

- / Residue from soaps and shampoos can cause damage. Rinse the product with clean water after each use.
- / Residue from basin/tub/tile cleaner can cause damage to faucets and fittings. Immediately rinse any overspray from the Hansgrohe product.
- / DO NOT store any cleaning agents under your Hansgrohe product, such as in a vanity unit, as the fumes may damage the product.
- / DAMAGE TO THE PRODUCT CAUSED BY IMPROPER CARE OR THE USE OF IMPROPER CLEANING AGENTS IS NOT COVERED BY THE WARRANTY.
- / IF A COMPONENT OF THE PRODUCT IS DAMAGED, REPLACE IT TO REDUCE THE RISK OF PERSONAL INJURY, PROPERTY DAMAGE OR PRODUCT FAILURE.

# CONSEIL DE NETTOYAGE POUR LES PRODUITS HANSGROHE

Les robinets pour les salles de bains et les cuisines modernes ainsi que les produits récents pour les douches se composent de matériaux différents afin de satisfaire aux besoins du marché en termes de conception et de fonctionnalité. Afin d'éviter d'endommager le produit, il est nécessaire d'en prendre soin.

## POUR DE MEILLEURS RÉSULTATS :

- / Empêchez l'accumulation de tarte et/ou de résidu de savon en nettoyant votre produit Hansgrohe lorsque c'est nécessaire.
- / Sélectionnez un produit de nettoyage spécifiquement prévu pour ce type de produit.
- / N'UTILISEZ PAS ces types de nettoyeurs car ils peuvent endommager votre produit Hansgrohe :
  - Tout produit de nettoyage contenant de l'acide chlorhydrique, de l'acide formique, de la potasse ou de l'acide acétique.
  - Les poudres de nettoyage, les tampons ou les brosses abrasives.
  - Les nettoyeurs à vapeur.
  - Les produits de nettoyage « sans rinçage ».
- / NE MÉLANGEZ PAS les produits de nettoyage, à moins que cela soit indiqué par le fabricant.
- / NE PULVÉRISEZ PAS les nettoyeurs directement sur le produit car des gouttes pourraient entrer dans les ouvertures et les fentes et causer des dommages. Lorsque vous utilisez des nettoyeurs par pulvérisation, pulvérisez le nettoyeur sur un chiffon ou une éponge douce.
- / Après le nettoyage rincer abondamment à l'eau claire pour éliminer intégralement les restes de détergent.

## IMPORTANT

- / Les résidus de produits pour le corps comme les savons liquides, shampooings, gels de douche, teintures pour cheveux, parfums, après-rasage et vernis à ongles peuvent causer des détériorations. Rincez le produit avec de l'eau propre après chaque utilisation.
- / Le résidu provenant des nettoyeurs pour cuvette/baignoire/carrelage peut endommager les robinets et les raccords de tuyauterie. Rincez immédiatement toute surpulvérisation sur le produit Hansgrohe.
- / De même, il est interdit de stocker des détergents ou des produits chimiques sous les produits, par ex. dans un meuble sous lavabo, car les vapeurs qui s'en dégagent risquent d'abîmer les produits.
- / LES DOMMAGES AU PRODUIT CAUSÉS PAR UN MAUVAIS ENTRETIEN OU PAR L'UTILISATION DE PRODUITS DE NETTOYAGE INADÉQUATS NE SONT PAS COUVERTS PAR LA GARANTIE.
- / SI UN COMPOSANT DU PRODUIT EST ENDOMMAGÉ, REMPLACEZ-LE POUR RÉDUIRE LES RISQUES DE BLESSURES, DE DOMMAGES MATÉRIELS OU DE DÉFAILLANCES DU PRODUIT.

# RECOMENDACIÓN DE LIMPIEZA PARA LOS PRODUCTOS DE HANSGROHE

Hoy en día, las griferías de baño y de cocina así como duchas modernas se componen de materiales muy distintos para satisfacer las exigencias del mercado respecto al diseño y la funcionalidad. Para evitar daños y reclamaciones hay que tener en cuenta ciertos aspectos tanto en el uso como en su limpieza.

## PARA OBTENER MEJORES RESULTADOS:

- / Evite la acumulación de restos de jabón o sarro limpiando el producto Hansgrohe cuando sea necesario.
- / Seleccione un agente de limpieza diseñado específicamente para el tipo de producto.
- / NO use estos tipos de limpiadores, ya que causarán daño a su producto Hansgrohe:
  - Agentes limpiadores que contengan ácido clorhídrico, fórmico, acético o lejía.
  - Polvos, paños o cepillos de limpieza abrasivos.
  - Limpiadores a vapor
  - Agentes de limpieza "sin enjuague".
- / SIEMPRE siga las instrucciones provistas por el fabricante del agente de limpieza.
- / NO mezcle los agentes de limpieza, a menos que esté indicado por el fabricante.
- / NO rocíe limpiadores directamente sobre el producto, ya que podrían caer gotas sobre las aberturas y espacios y causar daños. Cuando use limpiadores en spray, rocíe el limpiador sobre un paño suave o esponja.
- / SIEMPRE enjuague su producto Hansgrohe con agua limpia y séquelo y lístrela con un paño suave después de la limpieza.

## IMPORTANTE

- / Los residuos de productos de aseo como jabón líquido, champú, gel de ducha, tintes de pelo, perfumes, lociones de afeitado y esmalte de uñas pueden dañar también los materiales. Enjuague el producto con agua limpia después de cada uso.
- / Los residuos de limpiadores para lavatorios, bañeras o azulejos pueden causar daño a los grifos y accesorios. Enjuague inmediatamente cualquier derrame que haya sobre el producto de Hansgrohe.
- / Tampoco pueden generarse depósitos de productos de limpieza o químicos debajo de los productos, p. ej. En un armario de lavabo. De lo contrario, los vapores generados pueden dañar los productos.
- / LOS DAÑOS QUE RESULTEN DE UN CUIDADO INADECUADO O USO DE AGENTES DE LIMPIEZA INADECUADOS NO ESTÁN CUBIERTOS POR LA GARANTÍA.
- / SI UN COMPONENTE DEL PRODUCTO ESTÁ DAÑADO, REEMPLÁCELO PARA REDUCIR EL RIESGO DE LESIONES PERSONALES, DAÑOS A LA PROPIEDAD O FALLAS DEL PRODUCTO.

# HANSGROHE, INC. LIMITED WARRANTY

Offering our customers the highest quality at all times is a fundamental part of the Hansgrohe, Inc. company philosophy. We offer consumers a limited warranty on our hansgrohe® and AXOR® branded products.

This warranty is limited to products manufactured by Hansgrohe, Inc. that are purchased from a Hansgrohe, Inc. authorized seller by a consumer in the United States or Canada after September 1, 2019, and installed in either the United States or in Canada.

## WARRANTY

Hansgrohe, Inc. warrants to the original consumer purchaser that hansgrohe and AXOR products will be free from defects in material and workmanship for as long as the original consumer purchaser owns both the product and the home in which the product was originally installed. For commercial purchasers, the warranty period is (a) one (1) year for hansgrohe products and (b) five (5) years for AXOR products, in each case from the date of purchase. The warranty period for products in the Rubbed Bronze, Matte Black and Matte White finishes are three (3) years from the date of purchase. This warranty is non-transferable.

## WHAT WE WILL DO

Hansgrohe, Inc., at its option, will replace any product or part of the product that proves defective in workmanship and/or material, under normal installation, use, service and maintenance. If Hansgrohe, Inc. is unable to provide a replacement part or product and repair is not practical or cannot be made in timely fashion, Hansgrohe, Inc. may elect to refund the purchase price in exchange for the return of the defective product. REPAIR OR REPLACEMENT (OR, IN LIMITED CIRCUMSTANCES, REFUND OF THE PURCHASE PRICE) AS PROVIDED UNDER THIS LIMITED WARRANTY IS THE EXCLUSIVE REMEDY OF THE PURCHASER.

## WHAT IS NOT COVERED BY THE WARRANTY

Because Hansgrohe, Inc. is unable to control the quality of hansgrohe or AXOR products sold by unauthorized sellers, unless otherwise prohibited by law, this warranty does not cover hansgrohe or AXOR products purchased from unauthorized sellers. Authorized sellers can be found on hansgrohe and AXOR branded websites.

Labor and other expenses for disconnection, deinstallation, or return of the product for warranty service (including but not limited to proper packaging and shipping costs), or for installation or reinstallation of the product are not covered by this warranty.

Hansgrohe, Inc. shall not be liable for any damage to the product resulting from

- reasonable wear and tear
- outdoor use
- misuse (including use of the product for an unintended application)
- freezing water
- excessive water pressure
- pipe corrosion in the home in which the product is installed
- abuse, neglect or improper or incorrectly performed installation, maintenance or repair, including the use of abrasive or caustic cleaning agents or "no-rinse" cleaning products.

This warranty does not cover: (i) accessories, connected materials and products, or related products not manufactured by Hansgrohe, Inc. (ii) any hansgrohe or AXOR product sold for display purposes or (iii) hansgrohe or AXOR products purchased from unauthorized sellers.

## WHAT YOU MUST DO TO OBTAIN WARRANTY SERVICE OR INFORMATION

Contact your retailer, or contact Technical Service at:

Hansgrohe, Inc.  
1492 Bluegrass Lakes Parkway  
Alpharetta, GA 30004  
Toll-free 800-334-0455

In requesting warranty service, you will need to provide:

1. The sales receipt or other evidence of the date and place of purchase.
2. A description of the problem.
3. Delivery of the product or the defective part, postage prepaid and carefully packed and insured, to:

Hansgrohe, Inc.  
1492 Bluegrass Lakes Parkway  
Alpharetta, GA 30004  
Toll-free 800-334-0455

When warranty service is completed, any repaired or replacement product or part will be returned to you postage prepaid.

REVISED SEPTEMBER 1, 2019.

**LIMITATION ON DURATION OF IMPLIED WARRANTIES:** Some States do not allow limitations on how long an implied warranty lasts, so the below limitations may not apply to you. TO THE MAXIMUM EXTENT PERMITTED BY APPLICABLE LAW, ANY IMPLIED WARRANTY, INCLUDING THE IMPLIED WARRANTIES OF MERCHANTABILITY AND OF FITNESS FOR A PARTICULAR PURPOSE, IS LIMITED TO THE STATUTORY PERIOD OR THE DURATION OF THIS WARRANTY, WHICHEVER IS SHORTER.

**LIMITATION OF SPECIAL, INCIDENTAL OR CONSEQUENTIAL DAMAGES:** Some States do not allow the exclusion or limitation of incidental or consequential damages, so the below limitations and exclusions may not apply to you. TO THE MAXIMUM EXTENT PERMITTED BY APPLICABLE LAW, THIS WARRANTY DOES NOT COVER, AND HANSGROHE, INC. SHALL NOT BE LIABLE FOR, ANY SPECIAL, INCIDENTAL OR CONSEQUENTIAL DAMAGES (INCLUDING LABOR CHARGES TO REPAIR, REPLACE, INSTALL OR REMOVE THIS PRODUCT), WHETHER ARISING OUT OF BREACH OF ANY EXPRESS OR IMPLIED WARRANTY, BREACH OF CONTRACT, TORT, OR OTHERWISE. HANSGROHE, INC. SHALL NOT BE LIABLE FOR ANY DAMAGE TO THE PRODUCT RESULTING FROM REASONABLE WEAR AND TEAR, OUTDOOR USE, MISUSE (INCLUDING USE OF THE PRODUCT FOR AN UNINTENDED APPLICATION), FREEZING WATER, EXCESSIVE WATER PRESSURE, PIPE CORROSION IN THE HOME IN WHICH THE PRODUCT IS INSTALLED, ABUSE, NEGLIGENCE OR IMPROPER OR INCORRECTLY PERFORMED INSTALLATION, MAINTENANCE OR REPAIR, INCLUDING THE USE OF ABRASIVE OR CAUSTIC CLEANING AGENTS OR "NO-RINSE" CLEANING PRODUCTS.

**NOTICE TO RESIDENTS OF THE STATE OF NEW JERSEY:** The provisions of this warranty, including its limitations, are intended to apply to the fullest extent permitted by the laws of the State of New Jersey.

This warranty gives you specific legal rights, and you may also have other rights which vary from state to state.

## PRODUCT INSTRUCTIONS AND QUESTIONS

Upon purchase or prior to installation, please carefully inspect your product for any damage or visible defect. Prior to installing, always carefully study the enclosed instructions on the proper installation and the care and maintenance of this product.

If you have questions at any time about the use, installation or performance of your product, or the limited Warranty, please write us or call us toll-free at 800-334-0455.

# AXOR

AXOR / Hansgrohe, Inc.  
1490 Bluegrass Lakes Parkway  
Alpharetta, GA 30004  
Tel. 800-334-0455  
Fax 770-889-1783

[axor-design.com](http://axor-design.com)