

AXOR

DE / Gebrauchsanleitung / Montageanleitung	02
FR / Mode d'emploi / Instructions de montage	03
EN / Instructions for use / assembly instructions	04
IT / Istruzioni per l'uso / Istruzioni per Installazione	05
ES / Modo de empleo / Instrucciones de montaje	06
NL / Gebruiksaanwijzing / Handleiding	07
DK / Brugsanvisning / Monteringsvejledning	08
PT / Instruções para uso / Manual de Instalação	09
PL / Instrukcja obsługi / Instrukcja montażu	10
CS / Návod k použití / Montážní návod	11
SK / Návod na použitie / Montážny návod	12
ZH / 用户手册 / 组装说明	13
RU / Руководство пользователя / Инструкция по монтажу	14
FI / Käyttöohje / Asennusohje	15
SV / Bruksanvisning / Monteringsanvisning	16
LT / Vartotojo instrukcija / Montavimo instrukcijos	17
HR / Upute za uporabu / Uputstva za instalaciju	18
TR / Kullanım kılavuzu / Montaj kılavuzu	19
RO / Manual de utilizare / Instrucțiuni de montare	20
EL / Οδηγίες χρήσης / Οδηγία συναρμολόγησης	21
SL / Navodilo za uporabo / Navodila za montažo	22
ET / Kasutusjuhend / Paigaldusjuhend	23
LV / Lietošanas pamācība / Montāžas instrukcija	24
SR / Uputstvo za upotrebu / Uputstvo za montažu	25
NO / Bruksanvisning / Montasjeveiledning	26
BG / Инструкция за употреба / Ръководство за монтаж	27
SQ / Udhëzuesi i përdorimit / Udhëzime rreth montimit	28
AR / دليل الاستخدام / تعليمات التجميع	29
HU / Használati útmutató / Szerelési útmutató	30
JP / 取扱説明書 / 施工説明書	31

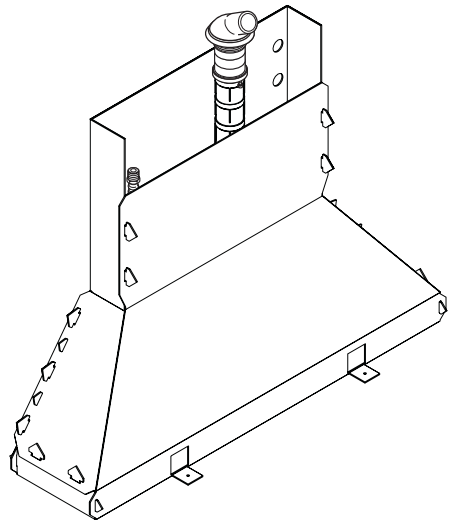

AXOR Secuflex
28382XXX

INSTALLATION

⚠ SICHERHEITSHINWEISE

- ⚠ Bei der Montage müssen zur Vermeidung von Quetsch- und Schnittverletzungen Handschuhe getragen werden.
- ⚠ Das Produkt darf nur zu Bade-, Hygiene- und Körperreinigungszwecken eingesetzt werden.
- ⚠ Das Produkt darf nicht als Haltegriff benutzt werden. Es muss ein separater Haltegriff montiert werden.

MONTAGEHINWEISE

- / Vor der Montage muss das Produkt auf Transportschäden untersucht werden. Nach dem Einbau werden keine Transport- oder Oberflächenschäden anerkannt.
- / Die Leitungen und die Armatur müssen nach den gültigen Normen montiert, gespült und geprüft werden.
- / Die in den Ländern jeweils gültigen Installationsrichtlinien sind einzuhalten.
- / Optimale Funktion nur in Verbindung mit Hansgrohe Handbrausen und Hansgrohe Brausenschläuchen garantiert.
- / Wird die Secuflex-Box falsch oder nicht installiert, erlischt die Gewährleistung.

TECHNISCHE DATEN

Freier Durchfluss bei 0,3 MPa: 24 l/min
(1 MPa = 10 bar = 147 PSI)

Thermische Desinfektion: max. 70°C/4 min

Eigensicher gegen Rückfließen

Das Produkt ist ausschließlich für Trinkwasser konzipiert!

SYMBOLERKLÄRUNG



Kein essigsäurehaltiges Silikon verwenden!

WARTUNG RÜCKFLUSSVERHINDERER

(siehe Seite 40)

Rückflussverhinderer müssen gemäß DIN EN 1717 regelmäßig in Übereinstimmung mit nationalen oder regionalen Bestimmungen auf ihre Funktion geprüft werden (mindestens einmal jährlich).

WARTUNG SECUFLEX SCHLAUCH

(siehe Seite 40)

Das Reinigen wiederholen, wenn im Laufe der Zeit der Auszug schwergängig wird.

MASSE (siehe Seite 37)



SERVICETEILE (siehe Seite 42)

XXX = Farbcodierung

000 = Chrom

020 = Polished Chrome

130 = Polished Bronze

140 = Brushed Bronze

250 = Brushed Gold-Optic

260 = Brushed Chrome

300 = Polished Redgold

310 = Brushed Redgold

330 = Polished Black Chrome

340 = Brushed Black Chrome

800 = Stainless Steel Optic

820 = Brushed Nickel

830 = Polished Nickel

930 = Polished Brass

950 = Brushed Brass

990 = Polished Gold-Optic



REINIGUNG (siehe Seite 38)



BEDIENUNG (siehe Seite 39)

⚠ CONSIGNES DE SÉCURITÉ

- ⚠ Lors du montage, porter des gants de protection pour éviter toute blessure par écrasement ou coupure.
- ⚠ Le produit ne doit servir qu'à se laver et à assurer l'hygiène corporelle.
- ⚠ Le produit ne doit pas servir de poignée. Monter pour cela une poignée séparée.

INSTRUCTIONS POUR LE MONTAGE

- / Avant son montage, s'assurer que le produit n'a subi aucun dommage pendant le transport. Après le montage, tout dommage de transport ou de surface ne pourra pas être reconnu.
- / Les conduites et la robinetterie doivent être montés, rincés et contrôlés selon les normes en vigueur.
- / Les directives d'installation en vigueur dans le pays concerné doivent être respectées.
- / Un fonctionnement optimal est seulement garanti en combinaison avec des douches à main et des flexibles Hansgrohe.
- / Si La Secuflex-Box est mal ou pas installée, la garantie sera annulée.

INFORMATIONS TECHNIQUES

Débit libre à 0,3 MPa: 24 l/min
 (1 MPa = 10 bar = 147 PSI)

Désinfection thermique: max. 70°C / 4 min

Avec dispositif anti-retour

Le produit est exclusivement conçu pour de l'eau potable!

DESCRIPTION DU SYMBOLE



Ne pas utiliser de silicone contenant de l'acide acétique!



ENTRETIEN CLAPET ANTI-RETOUR

(voir pages 40)

Les clapets anti-retour doivent être examinés régulièrement conformément à la norme EN 1717 ou conformément aux dispositions nationales ou régionales quant à leur fonction (au moins une fois par an).

ENTRETIEN SECUFLEX TUBE FLÉXIBLE

(voir pages 40)

Répétez cette action lorsque l'extraction devient difficile.



DIMENSIONS (voir pages 37)



PIÈCES DÉTACHÉES (voir pages 42)

XXX = Couleurs
 000 = Chromé
 020 = Polished Chrome
 130 = Polished Bronze
 140 = Brushed Bronze
 250 = Brushed Gold-Optic
 260 = Brushed Chrome
 300 = Polished Redgold
 310 = Brushed Redgold
 330 = Polished Black Chrome
 340 = Brushed Black Chrome
 800 = Stainless Steel Optic
 820 = Brushed Nickel
 830 = Polished Nickel
 930 = Polished Brass
 950 = Brushed Brass
 990 = Polished Gold-Optic



NETTOYAGE (voir pages 38)



INSTRUCTIONS DE SERVICE

(voir pages 39)

⚠ SAFETY NOTES

- ⚠ Gloves should be worn during installation to prevent crushing and cutting injuries.
- ⚠ The product may only be used for bathing, hygienic and body cleaning purposes.
- ⚠ The product may not be used as a holding handle. A separate handle must be installed.

INSTALLATION INSTRUCTIONS

- / Prior to installation, inspect the product for transport damages. After it has been installed, no transport or surface damage will be honoured.
- / The pipes and the fixture must be installed, flushed and tested as per the applicable standards.
- / The plumbing codes applicable in the respective countries must be observed.
- / Optimal functioning is only guaranteed with the combination of Hansgrohe hand showers and Hansgrohe shower hoses.
- / If the Secuflex-Box is installed improperly or not at all, the warranty will become invalid.

TECHNICAL DATA

Rate of flow by 0,3 MPa: 24 l/min
 (1 MPa = 10 bar = 147 PSI)

Thermal disinfection: max. 70°C / 4 min

Safety against backflow

The product is exclusively designed for drinking water!

SYMBOL DESCRIPTION



Do not use silicone containing acetic acid!

MAINTENANCE CHECK VALVE
 (see page 40)

The check valves must be checked regularly according to DIN EN 1717 in accordance with national or regional regulations (at least once a year).

MAINTENANCE SECUFLEX HOSE
 (see page 40)

Repeat cleaning when pull out becomes difficult.

DIMENSIONS (see page 37)



SPARE PARTS (see page 42)

XXX = Colors
 000 = Chrome Plated
 020 = Polished Chrome
 130 = Polished Bronze
 140 = Brushed Bronze
 250 = Brushed Gold-Optic
 260 = Brushed Chrome
 300 = Polished Redgold
 310 = Brushed Redgold
 330 = Polished Black Chrome
 340 = Brushed Black Chrome
 800 = Stainless Steel Optic
 820 = Brushed Nickel
 830 = Polished Nickel
 930 = Polished Brass
 950 = Brushed Brass
 990 = Polished Gold-Optic



CLEANING (see page 38)



OPERATION (see page 39)



△ INDICAZIONI SULLA SICUREZZA

- △ Durante il montaggio, per evitare ferite da schiacciamento e da taglio bisogna indossare guanti protettivi.
- △ Il prodotto deve essere utilizzato esclusivamente per fare il bagno e per l'igiene del corpo.
- △ Il prodotto non deve essere utilizzato come maniglia, questa deve essere montata separatamente.

ISTRUZIONI PER IL MONTAGGIO

- / Prima del montaggio è necessario controllare che non ci siano stati danni durante il trasporto. Una volta eseguito il montaggio, non verranno riconosciuti eventuali danni di trasporto o delle superfici.
- / Montare, lavare e controllare tubature e rubinetteria rispettando le norme correnti.
- / Vanno rispettate le direttive di installazione nazionali vigenti nel rispettivo paese.
- / Funzionalità ottimale solamente in combinazione con doccette e flessibili Hansgrohe.
- / La garanzia decade se il Secuflex-Box viene installato in modo sbagliato o per niente.

DATI TECNICI

Portata a 0,3 MPa: 24 l/min
(1 MPa = 10 bar = 147 PSI)

Disinfezione termica: max. 70°C / 4 min

Sicurezza antiriflusso

Il prodotto è concepito esclusivamente per acqua potabile!

DESCRIZIONE SIMBOLO



Non utilizzare silicone contenente acido acetico!

MANUTENZIONE VALVOLA ANTIRIFLUSSO

(vedi pagg. 40)

La valvola di non ritorno deve essere controllata regolarmente come da DIN EN 1717, secondo le normative nazionali e regionali (almeno una volta all'anno).

MANUTENZIONE SECUFLEX FLESSIBILE

(vedi pagg. 40)

Questa azione di pulizia deve essere ripetuta in caso, con il passare del tempo, l'apertura della placca diventi difficoltosa.



INGOMBRI (vedi pagg. 37)



PARTI DI RICAMBIO
(vedi pagg. 42)

XXX = Trattamento

000 = Cromato

020 = Polished Chrome

130 = Polished Bronze

140 = Brushed Bronze

250 = Brushed Gold-Optic

260 = Brushed Chrome

300 = Polished Redgold

310 = Brushed Redgold

330 = Polished Black Chrome

340 = Brushed Black Chrome

800 = Stainless Steel Optic

820 = Brushed Nickel

830 = Polished Nickel

930 = Polished Brass

950 = Brushed Brass

990 = Polished Gold-Optic



PULITURA (vedi pagg. 38)



PROCEDURA (vedi pagg. 39)



△ INDICACIONES DE SEGURIDAD

- △ Durante el montaje deben utilizarse guantes para evitar heridas por aplastamiento o corte.
- △ El producto solo debe ser utilizado para fines de baño, higiene y limpieza corporal.
- △ El producto no debe ser utilizado como un elemento de sujeción. Debe montarse un elemento de sujeción separado.

INDICACIONES PARA EL MONTAJE

- / Antes del montaje se debe examinar el producto contra daños de transporte. Después de la instalación no se reconoce ningún daño de transporte o de superficie.
- / Los conductos y la grifería deben montarse, lavarse y comprobarse según las normas vigentes.
- / Es obligatorio el cumplimiento de las directrices de instalación vigentes en el país respectivo.
- / Sólo se garantiza una función óptima en combinación con teleduchas y flexos de Hansgrohe.
- / La instalación errónea o la no instalación de la Secuflex-Box anulan la garantía.

DATOS TÉCNICOS

Caudal con 0,3 MPa 24 l/min

(1 MPa = 10 bar = 147 PSI)

Desinfección térmica: max. 70°C / 4 min

Seguro contra el retorno

El producto ha sido concebido exclusivamente para agua potable.

DESCRIPCIÓN DE SÍMBOLOS



No utilizar silicona que contiene ácido acético!

MANTENIMIENTO VÁLVULA ANTI-RETORNO

(ver página 40)

Las válvulas anti-retorno tienen que ser controladas regularmente según la norma DIN EN 1717, en acuerdo con las regulaciones nacionales o regionales (una vez al año, por lo menos).

MANTENIMIENTO FLEXO SECUFLEX

(ver página 40)

Repetir la limpieza, cuando el tiempo aumenta la resistencial al extraerlo.



DIMENSIONES (ver página 37)



REPUESTOS (ver página 42)

XXX = Acabados

000 = Cromado

020 = Polished Chrome

130 = Polished Bronze

140 = Brushed Bronze

250 = Brushed Gold-Optic

260 = Brushed Chrome

300 = Polished Redgold

310 = Brushed Redgold

330 = Polished Black Chrome

340 = Brushed Black Chrome

800 = Stainless Steel Optic

820 = Brushed Nickel

830 = Polished Nickel

930 = Polished Brass

950 = Brushed Brass

990 = Polished Gold-Optic



LIMPIAR (ver página 38)



MANEJO (ver página 39)



△ VEILIGHEIDSINSTRUCTIES

- △ Bij de montage moeten ter voorkoming van knel- en snijwonden handschoenen worden gedragen.
- △ Het product mag alleen voor het wassen, hygiënische doeleinden en voor de lichaamsreiniging worden gebruikt.
- △ Het product mag niet als handgreep worden gebruikt. Er moet een aparte handgreep gemonteerd worden.

MONTAGE-INSTRUCTIES

- / Vóór de montage moet het product gecontroleerd worden op transportschade. Na de inbouw wordt geen transport- of oppervlakteschade meer aanvaard.
- / De leidingen en armaturen moeten gemonteerd, gespoeld en gecontroleerd worden volgens de geldige normen.
- / De in de overeenkomstige landen geldende installatie-richtlijnen moeten nageleefd worden.
- / Optimal functioneren gegarandeerd bij combinatie met Hansgrohe handdouche en doucheslang.
- / Als de Secuflex-box verkeerd of niet wordt geïnstalleerd, vervalt de garantie.

TECHNISCHE GEGEVENS

Vrije doorstroom bij 0,3 MPa: 24 l/min
 (1 MPa = 10 bar = 147 PSI)

Thermische desinfectie: max. 70°C/4 min

Beveiligd tegen terugstromen

Het product is uitsluitend ontworpen voor drinkwater!

SYMBOOLBESCHRIJVING



Gebruik geen zuurhoudende siliconen!

ONDERHOUD TERUGSLAGKLEP

(zie blz. 40)

Keerklappen moeten volgens DIN EN 1717 regelmatig en volgens plaatselijk geldende eisen op het functioneren gecontroleerd worden. (Tenminste een keer per jaar)

ONDERHOUD SECUFLEX SLANG

(zie blz. 40)

U kunt deze handeling herhalen indien na verloop van tijd het uittrekken van de douche wat zwaarder gaat.

MATEN (zie blz. 37)



SERVICE ONDERDELEN

(zie blz. 42)



XXX = Kleuren
 000 = Verchromd
 020 = Polished Chrome
 130 = Polished Bronze
 140 = Brushed Bronze
 250 = Brushed Gold-Optic
 260 = Brushed Chrome
 300 = Polished Redgold
 310 = Brushed Redgold
 330 = Polished Black Chrome
 340 = Brushed Black Chrome
 800 = Stainless Steel Optic
 820 = Brushed Nickel
 830 = Polished Nickel
 930 = Polished Brass
 950 = Brushed Brass
 990 = Polished Gold-Optic



REINIGEN (zie blz. 38)



BEDIENING (zie blz. 39)



⚠ SIKKERHEDSANVISNINGER

- ⚠ Ved monteringen skal der bruges handsker for at undgå kvæstelser og snitsår.
- ⚠ Produktet må kun bruges til bade-, hygiejne og kropsurengøringsformål.
- ⚠ Produktet må ikke bruges som håndtag. Der skal monteres et separat håndtag.

MONTERINGSANVISNINGER

- / Før monteringen skal produktet kontrolleres for transportskader. Efter monteringen godkendes transportskader eller skader på overfladen ikke længere.
- / Ledningerne og armaturerne skal monteres, skylles og kontrolleres iht. de gældende standarder.
- / Installationsbestemmelserne, der gælder i det enkelte land, skal overholdes.
- / Optimal funktion garanteres for anvendelse i forbindelse med Hansgrohe håndbrusere og Hansgrohe bruseslanger.
- / Installeres Secuflex-Boxen forkert eller slet ikke, bortfalder garantien.

TEKNISKE DATA

Fri gennemstrømning ved 0,3 MPa: 24 l/min
(1 MPa = 10 bar = 147 PSI)

Termisk desinfektion: max. 70°C / 4 min

Med indbygget kontraventil

Produktet er udelukkende beregnet til drikkevand!

SYMBOLBESKRIVELSE



Der må ikke benyttes eddikesyreholdig silikone!

SERVICE KONTRAVENTIL

(se s. 40)

Ifølge DIN EN 1717 skal gennemstrømningsbegrænsere i overensstemmelse med nationale regler afprøves regelmæssigt (mindst en gang om året).

SERVICE SECUFLEX SLANGE

(se s. 40)

Venligst gentag rengøringen såfremt udtrækket med tiden bliver trægt.



MÅLENE (se s. 37)



RESERVEDELE (se s. 42)

XXX = Overflade
 000 = Krom
 020 = Polished Chrome
 130 = Polished Bronze
 140 = Brushed Bronze
 250 = Brushed Gold-Optic
 260 = Brushed Chrome
 300 = Polished Redgold
 310 = Brushed Redgold
 330 = Polished Black Chrome
 340 = Brushed Black Chrome
 800 = Stainless Steel Optic
 820 = Brushed Nickel
 830 = Polished Nickel
 930 = Polished Brass
 950 = Brushed Brass
 990 = Polished Gold-Optic



RENGØRING (se s. 38)



BRUGSANVISNING (se s. 39)



⚠ AVISOS DE SEGURANÇA

- ⚠ Durante a montagem devem ser utilizadas luvas de protecção, de modo a evitar ferimentos resultantes de entalamentos e de cortes.
- ⚠ O produto só pode ser utilizado para fins de higiene pessoal.
- ⚠ O produto não pode ser utilizado como pega de apoio. Tem que ser montada uma pega separada.

AVISOS DE MONTAGEM

- / Antes da montagem deve-se controlar o produto relativamente a danos de transporte. Após a montagem não são aceites quaisquer danos de transporte ou de superfície.
- / As tubagens e a torneira têm que ser montadas, enxaguadas e verificadas de acordo com as normas em vigor.
- / A prescrições de instalação válidas nos respetivos países devem ser respeitadas.
- / O bom funcionamento é apenas garantido em combinação com chuveiros de mão e tubos flexíveis Hansgrohe.
- / A garantia perde a sua validade se a Secuflex-Box for instalada incorretamente ou se não for instalada.

DADOS TÉCNICOS

Caudal a 0,3 MPa: 24 l/min

(1 MPa = 10 bar = 147 PSI)

Desinfecção térmica: max. 70°C / 4 min

Função anti-retorno e anti-vácuo

Este produto foi única e exclusivamente concebido para água potável!

DESCRIÇÃO DO SÍMBOLO



Não utilizar silicone que contenha ácido acético!



MANUTENÇÃO VÁLVULA ANTI-RETORNO

(ver página 40)

As válvulas anti-retorno devem ser verificadas regularmente de acordo com a DIN EN 1717 segundo os regulamentos nacionais ou regionais (pelo menos uma vez por ano).

MANUTENÇÃO SECUFLEX FLEXÍVEL

(ver página 40)

Limpe outra vez se for ainda difícil de puxar cano o tempo.



MEDIDAS (ver página 37)



PEÇAS DE SUBSTITUIÇÃO (ver página 42)

XXX = Acabamentos

000 = Cromado

020 = Polished Chrome

130 = Polished Bronze

140 = Brushed Bronze

250 = Brushed Gold-Optic

260 = Brushed Chrome

300 = Polished Redgold

310 = Brushed Redgold

330 = Polished Black Chrome

340 = Brushed Black Chrome

800 = Stainless Steel Optic

820 = Brushed Nickel

830 = Polished Nickel

930 = Polished Brass

950 = Brushed Brass

990 = Polished Gold-Optic



LIMPEZA (ver página 38)



FUNCIONAMENTO (ver página 39)



△ WSKAZÓWKI BEZPIECZEŃSTWA

- △ Aby uniknąć zranień na skutek zgniecenia lub przecięcia, podczas montażu należy nosić rękawice ochronne.
- △ Produkt może być używany tylko do kąpieli, higieny i czyszczenia ciała.
- △ Produktu nie wolno używać jako uchwytu do trzymania się. Należy zamontować osobny uchwyt.

WSKAZÓWKI MONTAŻOWE

- / Przed montażem należy skontrolować produkt pod kątem szkód transportowych. Po montażu nie widać żadnych szkód transportowych ani szkód na powierzchni.
- / Przewody i armatura muszą być montowane, płukane i kontrolowane według obowiązujących norm.
- / Należy przestrzegać wytycznych instalacyjnych obowiązujących w danym kraju.
- / Optymalne działanie gwarantuje się tylko w odniesieniu do przyszniców ręcznych i węży przysznicowych Hansgrohe.
- / Gwarancja wygasa w przypadku, gdy Secuflex-Box zamontowano niewłaściwie lub w ogóle jej nie zamontowano.

DANE TECHNICZNE

Swobodny przepływ przy 0,3 MPa: 24 l/min
(1 MPa = 10 bary = 147 PSI)

Dezynfekcja termiczna: maks. 70°C / 4 min

Zabezpieczony przed przepływem zwrotnym

Produkt przeznaczony wyłącznie do wody pitnej!

OPIS SYMBOLU



Nie stosować silikonów zawierających kwas octowy!



KONSERWACJA ZABEZPIECZENIE PRZED PRZEPŁYWEM ZWROTNYM

(patrz strona 40)

Zgodnie z normą DIN EN 1717, krajowymi i miejscowymi przepisami, działanie zabezpieczeń przed przepływem zwrotnym musi być kontrolowane (przynajmniej raz w roku).

KONSERWACJA WĄŻ SECUFLEX

(patrz strona 40)

W przypadku, gdy wyciąg pracuje z wysiłkiem, powtórzyć czyszczenie.



WYMIARY (patrz strona 37)



CZĘŚCI SERWISOWE

(patrz strona 42)

XXX = Kody kolorów

000 = Chrom

020 = Polished Chrome

130 = Polished Bronze

140 = Brushed Bronze

250 = Brushed Gold-Optic

260 = Brushed Chrome

300 = Polished Redgold

310 = Brushed Redgold

330 = Polished Black Chrome

340 = Brushed Black Chrome

800 = Stainless Steel Optic

820 = Brushed Nickel

830 = Polished Nickel

930 = Polished Brass

950 = Brushed Brass

990 = Polished Gold-Optic



CZYSZCZENIE (patrz strona 38)



OBSŁUGA (patrz strona 39)

△ BEZPEČNOSTNÍ POKYNY

- △ Pro zabránění řezným zraněním a pohmožděninám je nutné při montáži nosit rukavice.
- △ Produkt smí být používán pouze ke koupání a za účelem tělesné hygieny.
- △ Produkt nesmí být používán jako madlo. Je nutné namontovat samostatné madlo.

POKYNY K MONTÁŽI

- / Před montáží je třeba produkt zkontrolovat, zda nebyl při transportu poškozen. Po zabudování nebudou uznány žádné škody způsobené transportem nebo poškození povrchu.
- / Vedení a armatura musí být namontovány, propláchnuty a otestovány podle platných norem.
- / Je třeba dodržovat montážní pravidla platné v dané zemi.
- / Optimální funkce je zaručena pouze s ručními sprchami a sprchovými hadicemi Hansgrohe.
- / Pokud není nainstalován Secuflex-Box nebo byla instalace provedena nesprávně, je ručení vyloučeno.

TECHNICKÉ ÚDAJE

Volný průtok při 0,3 MPa 24 l/min
 (1 MPa = 10 bar = 147 PSI)

Tepelná dezinfekce: max. 70°C / 4 min

Vlastní jištění proti zpětnému nasátí.

Výrobky Hansgrohe jsou vhodné pro přímý kontakt s pitnou vodou.

POPIS SYMBOLŮ



Nepoužívat silikon s obsahem kyseliny octové!

ÚDRŽBA ZPĚTNÝ VENTIL

(viz strana 40)

U zpětných ventilů se musí podle DIN EN 1717 v souladu s národními nebo regionálními předpisy testovat jejich funkčnost (alespoň jednou ročně).

ÚDRŽBA HADICE SECUFLEX

(viz strana 40)

Opakovat čištění, pokud je po čase vytáhnutí obtížné.



ROZMĚRY (viz strana 37)

SERVISNÍ DÍLY (viz strana 42)

XXX = Kód povrchové úpravy

000 = Chrom

020 = Polished Chrome

130 = Polished Bronze

140 = Brushed Bronze

250 = Brushed Gold-Optic

260 = Brushed Chrome

300 = Polished Redgold

310 = Brushed Redgold

330 = Polished Black Chrome

340 = Brushed Black Chrome

800 = Stainless Steel Optic

820 = Brushed Nickel

830 = Polished Nickel

930 = Polished Brass

950 = Brushed Brass

990 = Polished Gold-Optic



ČIŠTĚNÍ (viz strana 38)



OVLÁDÁNÍ (viz strana 39)

△ BEZPEČNOSTNÉ POKYNY

- △ Pri montáži musíte nosiť rukavice, aby ste predišli pomliaždeninám a rezným poraneniam.
- △ Produkt sa smie používať len na kúpanie a telesnú hygienu.
- △ Výrobok sa nesmie používať ako držadlo. K tomu účelu sa musí namontovať samostatné držadlo.

POKYNY PRE MONTÁŽ

- / Pred montážou musíte produkt skontrolovať, či nebol počas transportu poškodený. Po zabudovaní nebudú uznané žiadne škody spôsobené transportom alebo poškodenia povrchu.
- / Potrubia a vybavenie musia byť namontované, prepláchnuté a vybavené v platnom normami.
- / Je potrebné dodržiavať smernice o inštalácii, ktoré sú práve teraz platné v krajinách.
- / Optimálna funkcia je zaručená iba s ručnými sprchami a sprchovými hadicami Hansgrohe.
- / Ak sa skrinka Secuflex-Box nainštaluje nesprávne alebo sa nenainštaluje vôbec, zaniká záruka.

TECHNICKÉ ÚDAJE

Volný prietok pri 0,3 MPa 24 l/min

(1 MPa = 10 bar = 147 PSI)

Termická dezinfekcia: max. 70°C / 4 min

Vlastná poisťka proti spätnému nasatiu.

Výrobok je koncipovaný výhradne pre pitnú vodu!

POPIS SYMBOLOV



Nepoužívať silikón s obsahom kyseliny octovej!

ÚDRŽBA OBMEDZOVAČ SPÄTNÉHO NASATIA

(viď strana 40)

Pri spätných ventiloch sa musí podľa DIN EN 1717 v súlade s národnými alebo regionálnymi predpismi testovať ich funkčnosť (aspoň raz ročne).

ÚDRŽBA HADICA SECUFLEX

(viď strana 40)

Zopakujte čistenie, ak sa v priebehu času sťažilo vyfahovanie.



ROZMERY (viď strana 37)



SERVISNÉ DIELY (viď strana 42)

XXX = Farebné označenie

000 = Chróm

020 = Polished Chrome

130 = Polished Bronze

140 = Brushed Bronze

250 = Brushed Gold-Optic

260 = Brushed Chrome

300 = Polished Redgold

310 = Brushed Redgold

330 = Polished Black Chrome

340 = Brushed Black Chrome

800 = Stainless Steel Optic

820 = Brushed Nickel

830 = Polished Nickel

930 = Polished Brass

950 = Brushed Brass

990 = Polished Gold-Optic



ČISTENIE (viď strana 38)



OBSLUHA (viď strana 39)



△ 安全技巧

- △ 装配时为避免挤压和切割受伤，必须戴上手套。
- △ 本产品只允许作为洗浴、卫生和洁身之用。
- △ 该产品不得作扶柄使用。必须安装单独的扶柄。

安装提示

- / 安装前必须检查产品是否受到运输损害。安装后将不认可运输损害或表面损伤。
- / 管道和阀门必须根据通用标准进行安装、冲洗和检查。
- / 请遵守当地国家现行的安装规定。
- / 请搭配使用汉斯格雅的手持花洒以及花洒软管以确保最佳的使用效果。
- / 如果 Secuflex-Box 安装错误或未安装，则质保失效。

技术参数

0,3 MPa时的流速: 24 升/分钟
 (1 MPa = 10 bar = 147 PSI)
 热力消毒: 最大 70°C / 4 分钟

自动防止回流

该产品专为饮用水设计！

符号说明



请勿使用含有乙酸的硅胶！

保养 单向阀

(参见第页 40)

单向阀必须在符合国家或当地的法律的情况下按照DIN EN 1717定期检查 (至少一年一次)。

保养 Secuflex 软管

(参见第页 40)

当手持花洒随着时间的推移变得抽拉困难时，重复上述清理工作。

大小 (参见第页 37)



备用零件 (参见第页 42)

XXX = 颜色代码

000 = 镀铬

020 = Polished Chrome

130 = Polished Bronze

140 = Brushed Bronze

250 = Brushed Gold-Optic

260 = Brushed Chrome

300 = Polished Redgold

310 = Brushed Redgold

330 = Polished Black Chrome

340 = Brushed Black Chrome

800 = Stainless Steel Optic

820 = Brushed Nickel

830 = Polished Nickel

930 = Polished Brass

950 = Brushed Brass

990 = Polished Gold-Optic



清洗 (参见第页 38)

操作 (参见第页 39)

△ УКАЗАНИЯ ПО ТЕХНИКЕ БЕЗОПАСНОСТИ

- △ Во время монтажа следует надеть перчатки во избежание прищемления и порезов.
- △ Изделие разрешается использовать только в гигиенических целях: для принятия ванны и личной гигиены.
- △ Изделие запрещается использовать в качестве рукоятки. Следует устанавливать специальную рукоятку.

УКАЗАНИЯ ПО МОНТАЖУ

- / Перед монтажом следует проверить изделие на предмет повреждений при перевозке. После монтажа претензии о возмещении ущерба за повреждения при перевозке или повреждения поверхностей не принимаются.
- / Трубы и арматура должны быть установлены, промыты и проверены в соответствии с действующими нормами.
- / Необходимо соблюдать требования по монтажу, действующие в соответствующих странах.
- / Оптимальное функционирование гарантируется только при использовании в комбинации с ручными душами Hansgrohe и душевыми шлангами Hansgrohe.
- / Если Secuflex-Vox установлен неправильно или не установлен совсем, гарантия утрачивает силу.

ТЕХНИЧЕСКИЕ ДАННЫЕ

Свободное истечение при 0,3 МПа: 24 л/мин
(1 МПа = 10 bar = 147 PSI)

Термическая дезинфекция: не более 70°C/4 мин
укомплектован клапаном обратного тока воды

Изделие предназначено исключительно для питьевой воды!

ОПИСАНИЕ СИМВОЛОВ



Не применяйте силикон, содержащий искусственную кислоту.



ТЕХНИЧЕСКОЕ ОБСЛУЖИВАНИЕ ЗАЩИТА ОБРАТНОГО ТОКА ВОДЫ

(см. стр. 40)

Защита обратного тока должна регулярно проверяться (минимум один раз в год) по стандарту DIN EN 1717 или в соответствии с национальными или региональными нормативами

ТЕХНИЧЕСКОЕ ОБСЛУЖИВАНИЕ ШЛАНГ SECUFLEX

(см. стр. 40)

Повторите очистку, если со временем вытягивание затрудняется.



РАЗМЕРЫ (см. стр. 37)



КОМПЛЕКТ (см. стр. 42)

XXX = Цветная кодировка
000 = Хром
020 = Polished Chrome
130 = Polished Bronze
140 = Brushed Bronze
250 = Brushed Gold-Optic
260 = Brushed Chrome
300 = Polished Redgold
310 = Brushed Redgold
330 = Polished Black Chrome
340 = Brushed Black Chrome
800 = Stainless Steel Optic
820 = Brushed Nickel
830 = Polished Nickel
930 = Polished Brass
950 = Brushed Brass
990 = Polished Gold-Optic



ОЧИСТКА (см. стр. 38)



ЭКСПЛУАТАЦИЯ (см. стр. 39)



△ TURVALLISUUSOHJEET

- △ Asennuksessa on käytettävä käsineitä puristumien ja viiltojen aiheuttamien tapaturmien estämiseksi.
- △ Tuotetta saa käyttää ainoastaan kylpy-, hygienia- ja puhdistustarkoituksiin.
- △ Tuotetta ei saa käyttää kädensijana. On asennettava erillinen kädensija.

A SENNUSOHJEET

- / Ennen asennusta on tarkastettava tuotteen mahdolliset kuljetusvahingot. Asennuksen jälkeen kuljetus- ja pintavaurioita ei hyväksytä.
- / Putket ja hana on asennettava, huuhdeltava ja tarkastettava voimassa olevien standardien mukaisesti.
- / Jokaisessa maassa on noudatettava siellä päteviä asennusohjeita.
- / Optimaalinen toiminta on taattuna vain Hansgrohe käsivihkuja ja Hansgrohe suihkuletkuja käytettäessä.
- / Jos Secuflex-Box asennetaan väärin tai ei ollenkaan, takuu ei ole voimassa.

TEKNISET TIEDOT

Vapaa läpivirtaus 0,3 MPa paineella: 24 l/min
(1 MPa = 10 bar = 147 PSI)

Lämpödesinfektio: maks. 70°C/4 min

Estää itsestään paluuvirtauksen

Tuote on suunniteltu käytettäväksi ainoastaan juomaveden kanssa!

MERKIN KUVAUS



Älä käytä etikkahappopitoista silikonia!

HUOLTO VASTAVENTTIILI

(katso sivu 40)

Vastaventtiilin toiminta on tarkastettava säännöllisesti paikallisten ja kansallisten määräysten mukaisesti (DIN EN 1717, vähintään kerran vuodessa).

HUOLTO SECUFLEX LETKU

(katso sivu 40)

Toista puhdistus, jos ulosveto tulee ajan kuluessa raskaaksi.



MITAT (katso sivu 37)



VARAOSAT (katso sivu 42)

XXX = Värikooodaus
 000 = Kromi
 020 = Polished Chrome
 130 = Polished Bronze
 140 = Brushed Bronze
 250 = Brushed Gold-Optic
 260 = Brushed Chrome
 300 = Polished Redgold
 310 = Brushed Redgold
 330 = Polished Black Chrome
 340 = Brushed Black Chrome
 800 = Stainless Steel Optic
 820 = Brushed Nickel
 830 = Polished Nickel
 930 = Polished Brass
 950 = Brushed Brass
 990 = Polished Gold-Optic



PUHDISTUS (katso sivu 38)



KÄYTTÖ (katso sivu 39)



△ SÄKERHETSANVISNINGAR

- △ Handskar ska bäras under monteringsarbetet så att man kan undvika kläm- och skärskador.
- △ Produkten får bara användas till kroppshygien med bad och dusch.
- △ Produkten får inte användas som handtag. Ett separat handtag måste monteras.

MONTERINGSANVISNINGAR

- / Det måste undersökas om produkten har transportskador innan den monteras. Efter monteringen accepteras inga transport- eller ytskiktsskador.
- / Ledningarna och blandaren måste monteras, spolats igenom och kontrolleras enligt de gällande normerna.
- / De installationsriktlinjer som gäller i länderna ska följas.
- / Optimal funktion garanteras bar tillsammans med Hansgrohe handduschar och Hansgrohe duschslangar.
- / Om Secuflex-Box installeras felaktigt eller inte förfaller garantin.

TEKNISKA DATA

Fri genomströmning vid 0,3 MPa: 24 l/min

(1 MPa = 10 bar = 147 PSI)

Termisk desinfektion: max. 70°C/4 min

Självspärr mot återflöde

Produkten är enbart avsedd för dricksvatten!

SYMBOLFÖRKLARING



Använd inte silikon som innehåller ättiksyra!

SKÖTSEL BACKVENTIL

(se sidan 40)

Backventilens funktion måste kontrolleras regelbundet enligt nationella eller regionala bestämmelser i enlighet med DIN EN 1717 (minst en gång per år).

SKÖTSEL SECUFLEX SLANG

(se sidan 40)

Upprepa rengöringen om utdragsenheten börjar bli trög.



MÅTTEN (se sidan 37)



RESERVDELAR (se sidan 42)

XXX = Färgkodning

000 = Krom

020 = Polished Chrome

130 = Polished Bronze

140 = Brushed Bronze

250 = Brushed Gold-Optic

260 = Brushed Chrome

300 = Polished Redgold

310 = Brushed Redgold

330 = Polished Black Chrome

340 = Brushed Black Chrome

800 = Stainless Steel Optic

820 = Brushed Nickel

830 = Polished Nickel

930 = Polished Brass

950 = Brushed Brass

990 = Polished Gold-Optic



RENGÖRING (se sidan 38)



HANTERING (se sidan 39)



△ SAUGUMO TECHNIKOS NURODYMAI

- △ Apsaugai nuo užspaudimo ir įsijovimo montavimo metu mūvėkite pirštines.
- △ Gaminys turi būti naudojamas tik maudymuisi, kūno higienai ir švarai palaikyti.
- △ Gaminys neturi būti naudojamas kaip rankena. Rankena montuojama atskirai.

MONTAVIMO INSTRUKCIJA

- / Prieš montuojant būtina patikrinti, ar gaminys nebuvo pažeistas transportavimo metu. Sumontavus pretenzijos dėl transportavimo ir paviršiaus pažeidimų nepriimamos.
- / Vamzdžiai ir sujungimai turi būti montuojami, plaunami ir tikrinami pagal galiojančias normas.
- / Laikykitės atitinkamoje šalyje galiojančių direktyvų dėl įrengimo.
- / Optimalus funkcionavimas yra garantuojamas tik naudojant "Hansgrohe" rankų dušus su "Hansgrohe" dušo žarnomis.
- / Jei „Secuflex-Box“ įrengiama netinkamai ar visai neįrengiama, nebetaikoma garantija.

TECHNINIAI DUOMENYS

Laisvas vandens pralaidumas esant 0,3 MPa slėgiui: 24 l/min
(1 MPa = 10 barų = 147 PSI)

Terminis dezinfekavimas: ne daugiau kaip 70°C/4 min

Su atbuliniu vožtuvu

Produktas skirtas tik geriamajam vandeniui!

SIMBOLIO APRAŠYMAS



Nenaudokite silikono, kurio sudėtyje yra acto rūgšties!



TECHNINIS APTARNAVIMAS ATBULINIS VOŽTUVAS

(žr. psl. 40)

Atbulinio vožtuvo apsauga privalo būti tikrinama reguliariai (mažiausiai kartą per metus) pagal DIN EN1717 arba pagal galiojančias nacionalines arba regionines normas.

TECHNINIS APTARNAVIMAS SECUFLES ŽARNA

(žr. psl. 40)

Valyti pakartotinai, jei ištraukti būna vis sunkiau.



IŠMATAVIMAI (žr. psl. 37)



ATSARGINĖS DALYS (žr. psl. 42)

XXX = Spalvos

000 = Chrom

020 = Polished Chrome

130 = Polished Bronze

140 = Brushed Bronze

250 = Brushed Gold-Optic

260 = Brushed Chrome

300 = Polished Redgold

310 = Brushed Redgold

330 = Polished Black Chrome

340 = Brushed Black Chrome

800 = Stainless Steel Optic

820 = Brushed Nickel

830 = Polished Nickel

930 = Polished Brass

950 = Brushed Brass

990 = Polished Gold-Optic



VALYMAS (žr. psl. 38)



EKSPLOATACIJA (žr. psl. 39)



⚠ SIGURNOSNE UPUTE

- ⚠ Prilikom montaže se radi sprječavanja prignječenja i posjekotina moraju nositi rukavice.
- ⚠ Proizvod se smije primjenjivati samo za kupanje, tuširanje i osobnu higijenu.
- ⚠ Proizvod ne smije služiti za pridržavanje. U tu se svrhu mora postaviti zaseban rukohvat.

UPUTE ZA MONTAŽU

- / Prije montaže mora se provjeriti je li proizvod oštećen prilikom transporta. Nakon ugradnje se ne priznaju nikakve reklamacije koje se odnose na površinska i transportna oštećenja.
- / Cijevi i armatura moraju biti postavljeni, isprani i testirani prema važećim normama.
- / Obvezno se moraju uvažiti propisi o instalacijama koji vrijede u dotičnoj zemlji.
- / Optimalno funkcioniranje zajamčeno je jedino u kombinaciji sa Hansgrohe ručnim tuševima i Hansgrohe crijevom za tuš.
- / Ako se Secuflex-Box pogrešno ili uopće ne instalira, gubi se pravo na reklamacije.

TEHNIČKI PODATCI

Slobodan protok na 0,3 MPa: 24 l/min
(1 MPa = 10 bar = 147 PSI)

Termička dezinfekcija: tlak 70°C/4 min

Funkcije samo-čišćenja

Proizvod je koncipiran isključivo za pitku vodu!

OPIS SIMBOLA



Nemojte koristiti silikon koji sadrži octenu kiselinu!



ODRŽAVANJE NEPOVRATNI
VENTIL

(pogledaj stranicu 40)

Ispravnost nepovratnog ventila mora se redovito provjeravati prema standardu DIN EN 1717 i u skladu sa važećim propisima (najmanje jednom godišnje).

ODRŽAVANJE SECUFLEX GIPKA
CIJEV

(pogledaj stranicu 40)

Ukoliko nakon nekog vremena voda i dalje slabo istječe, ponovite čišćenje



MJERE (pogledaj stranicu 37)



REZERVNI DJELOVI
(pogledaj stranicu 42)

XXX = Boje

000 = Krom

020 = Polished Chrome

130 = Polished Bronze

140 = Brushed Bronze

250 = Brushed Gold-Optic

260 = Brushed Chrome

300 = Polished Redgold

310 = Brushed Redgold

330 = Polished Black Chrome

340 = Brushed Black Chrome

800 = Stainless Steel Optic

820 = Brushed Nickel

830 = Polished Nickel

930 = Polished Brass

950 = Brushed Brass

990 = Polished Gold-Optic



ČIŠĆENJE (pogledaj stranicu 38)



UPO TREBA (pogledaj stranicu 39)

△ GÜVENLİK UYARILARI

- △ Montaj esnasında ezilme ve kesilme gibi yaralanmaları önlemek için eldiven kullanılmalıdır.
- △ Ürün yalnızca banyo, hijyen ve beden temizliği amaçları doğrultusunda kullanılabilir.
- △ Ürün tutma kolu olarak kullanılmamalıdır. Ayrı bir tutma kolu monte edilmelidir.

MONTAJ AÇIKLAMALARI

- / Montaj işleminden önce ürün nakliye hasarları yönünden kontrol edilmelidir. Montaj işleminden sonra nakliye veya yüzey hasarları için sorumluluk üstlenilmemektedir.
- / Boruların ve armatürün montajı, yıkanması ve kontrolü geçerli normlara göre yapılmalıdır.
- / Ülkelerde geçerli kurulum yönetmeliklerine riayet edilmelidir.
- / Mümkün olduğu kadar iyi işlev, yalnız Hansgrohe elle duş parçaları ve Hansgrohe duş boruları kullanılırsa, garanti edilir.
- / Secuflex-Box yanlış kurulursa veya hiç kurulmazsa, garanti hizmeti sona erer.

TEKNİK BİLGİLER

0,3 MPa serbest akış: 24 l/dak
(1 MPa = 10 bar = 147 PSI)

Termik dezenfeksiyon: azami 70°C/4 dak

Geri emme önleyici

Ürün sadece şebeke suyu için tasarlanmıştır!

SİMGE AÇIKLAMASI



Asetik asit içeren silikon kullanmayın!

BAKIM ÇEK VALF

(bakınız sayfa 40)

DIN EN 1717 ve ulusal standartlar doğrultusunda Çek valfler düzenli olarak kontrol edilmelidir. (en az yılda bir kez)

BAKIM SECUFLEX HORTUM

(bakınız sayfa 40)

Zaman için dışarı çekme zorlaşırsa temizliği tekrarlayın.



ÖLÇÜLERİ (bakınız sayfa 37)



YEDEK PARÇALAR (bakınız sayfa 42)

XXX = Renkler
000 = Krom
020 = Polished Chrome
130 = Polished Bronze
140 = Brushed Bronze
250 = Brushed Gold-Optic
260 = Brushed Chrome
300 = Polished Redgold
310 = Brushed Redgold
330 = Polished Black Chrome
340 = Brushed Black Chrome
800 = Stainless Steel Optic
820 = Brushed Nickel
830 = Polished Nickel
930 = Polished Brass
950 = Brushed Brass
990 = Polished Gold-Optic



TEMİZLEME (bakınız sayfa 38)



KULLANIMI (bakınız sayfa 39)



⚠ INSTRUCȚIUNI DE SIGURANȚĂ

- ⚠ La montare utilizați mănuși pentru evitarea contuziunilor și tăierii mâinilor.
- ⚠ Produsul poate fi utilizat doar pentru spălarea, menținerea igienei și curățarea corpului.
- ⚠ Nu este permisă utilizarea produsului pe post de mâner. este nevoie de montarea unui mâner corespunzător.

INSTRUCȚIUNI DE MONTARE

- / Înainte de instalare verificați, dacă produsul prezintă deteriorări de transport. După instalare garanția nu acoperă deteriorările de transport și cele de suprafață.
- / Conductele și bateriile trebuie montate, spălate și verificate conform normelor în vigoare.
- / Respectați reglementările referitoare la instalare valabile în țara respectivă.
- / Funcționarea optimă este garantată numai când estei conectat la duș de mână și furtun de duș marca Hansgrohe.
- / Dacă Secuflex-Box se instalează incorect sau nu se instalează deloc, garanția își pierde valabilitatea.

DATE TEHNICE

Debit cu curgere liberă la 0,3 MPa: 24 l/min
(1 MPa = 10 bar = 147 PSI)

Dezinfecție termică: max. 70°C / 4 min

Asigurat contra scurgere înapoi

Produsul este destinat exclusiv pentru apă potabilă.

DESCRIEREA SIMBOLURILOR



Nu utilizați silicon cu conținut de acid acetic!

ÎNTREȚINERE SUPAPĂ DE REȚINERE

(vezi pag. 40)

Supapele antiretur trebuie verificate regulat conform DIN EN 1717 și standardele naționale sau regionale (cel puțin o dată pe an).

ÎNTREȚINERE FURTUN SECUFLEX

(vezi pag. 40)

Curățați aparatul dacă furtunul nu se mai poate extrage ușor.



DIMENSIUNI (vezi pag. 37)



PIESE DE SCHIMB (vezi pag. 42)

XXX = Coduri de culori

000 = Crom

020 = Polished Chrome

130 = Polished Bronze

140 = Brushed Bronze

250 = Brushed Gold-Optic

260 = Brushed Chrome

300 = Polished Redgold

310 = Brushed Redgold

330 = Polished Black Chrome

340 = Brushed Black Chrome

800 = Stainless Steel Optic

820 = Brushed Nickel

830 = Polished Nickel

930 = Polished Brass

950 = Brushed Brass

990 = Polished Gold-Optic



CURĂȚARE (vezi pag. 38)



UTILIZARE (vezi pag. 39)



Δ ΥΠΟΔΕΙΞΕΙΣ ΑΣΦΑΛΕΙΑΣ

- Δ Για να αποφύγετε τραυματισμούς κατά τη συναρμολόγηση πρέπει να φοράτε γάντια.
- Δ Το προϊόν επιτρέπεται να χρησιμοποιείται μόνο σαν μέσο λουτρού, υγιεινής και καθαρισμού του σώματος.
- Δ Το προϊόν δεν επιτρέπεται να χρησιμοποιείται σαν λαβή στήριξης. Για τον σκοπό αυτό πρέπει να τοποθετηθεί ξεχωριστή λαβή στήριξης.

ΟΔΗΓΙΕΣ ΣΥΝΑΡΜΟΛΟΓΗΣΗΣ

- / Πριν τη συναρμολόγηση πρέπει να εξεταστεί το προϊόν για ζημιές μεταφοράς. Μετά την εγκατάσταση δεν αναγνωρίζονται ζημιές από τη μεταφορά ή επιφανειακές ζημιές.
- / Οι σωλήνες και η μπαταρία πρέπει να τοποθετηθούν σύμφωνα με τα ισχύοντα πρότυπα, να τεθούν υπό πίεση και να δοκιμαστούν.
- / Θα πρέπει να τηρούνται οι οδηγίες εγκατάστασης που ισχύουν σε κάθε κράτος.
- / Εγγύηση βέλτιστης λειτουργίας μόνο σε συνδυασμό με καταιονιστήρα χειρός Hansgrohe και σπирάλ Hansgrohe.
- / Εάν το Secuflex-Box τοποθετηθεί λάθος ή δεν εγκατασταθεί, ακυρώνεται η εργοστασιακή εγγύηση.

ΤΕΧΝΙΚΑ ΧΑΡΑΚΤΗΡΙΣΤΙΚΑ

Ελεύθερη ροή στα 0,3 MPa: 24 l/min
(1 MPa = 10 bar = 147 PSI)

Θερμική απολύμανση: έως 70°C / 4 min

Περιλαμβάνει βαλβίδα αντεπιστροφής.

Το προϊόν έχει σχεδιαστεί αποκλειστικά για πόσιμο νερό!

ΠΕΡΙΓΡΑΦΗ ΣΥΜΒΟΛΩΝ



Μην χρησιμοποιείτε σιλικόνη που περιέχει οξικό οξύ!



ΣΥΝΤΗΡΗΣΗ ΒΑΛΒΙΔΑ ΑΝΤΕΠΙΣΤΡΟΦΗΣ

(βλ. Σελίδα 40)

Οι βαλβίδες αντεπιστροφής πρέπει να ελέγχονται τακτικά ως προς τη λειτουργία τους, σύμφωνα με το πρότυπο DIN EN 1717, σε σχέση με τους ισχύοντες εθνικούς ή τοπικούς κανόνες (το ελάχιστο μια φορά το χρόνο) .

ΣΥΝΤΗΡΗΣΗ ΣΠΙΡΑΛ SECUFLEX ΜΗΚΟΥΣ

(βλ. Σελίδα 40)

Επαναλάβετε τον καθαρισμό, εάν καταστεί δύσκολη η έξοδος νερού στη διάρκεια του χρόνου.



ΔΙΑΣΤΑΣΕΙΣ (βλ. Σελίδα 37)



ΑΝΤΑΛΛΑΚΤΙΚΑ (βλ. Σελίδα 42)

XXX = Χρώματα

000 = Επιχρωμιωμένο

020 = Polished Chrome

130 = Polished Bronze

140 = Brushed Bronze

250 = Brushed Gold-Optic

260 = Brushed Chrome

300 = Polished Redgold

310 = Brushed Redgold

330 = Polished Black Chrome

340 = Brushed Black Chrome

800 = Stainless Steel Optic

820 = Brushed Nickel

830 = Polished Nickel

930 = Polished Brass

950 = Brushed Brass

990 = Polished Gold-Optic



ΚΑΘΑΡΙΣΜΟΣ (βλ. Σελίδα 38)



ΧΕΙΡΙΣΜΟΣ (βλ. Σελίδα 39)



△ VARNOSTNA OPOZORILA

- △ Pri montaži je treba nositi rokavice, da se preprečijo poškodbe zaradi zmečkanja ali urezov.
- △ Ta izdelek se sme uporabljati le z namenom umivanja, vzdrževanja higiene in telesne nege.
- △ Proizvoda ne smete uporabljati kot držalnega ročaja. V ta namen je treba montirati poseben ročaj.

NAVODILA ZA MONTAŽO

- / Pred montažo je treba izdelek preveriti glede morebitnih transportnih poškodb. Po vgradnji transportne ali površinske poškodbe ne bodo več priznane.
- / Cevi in armaturo je treba montirati, izprati in preveriti po veljavnih standardih.
- / Upoštevati je treba pravilnike o inštalacijah, ki veljajo v posamezni državi.
- / Optimalno delovanje je zagotovljeno le v povezavi z ročnimi prhami Hansgrohe in gibkimi cevmi za prho Hansgrohe.
- / Če se zaboj Secuflex-Box narobe ali pa se ga sploh ne montira, ugasne pravica do garancije.

TEHNIČNI PODATKI

Prost pretok pri 0,3 MPa: 24 l/min

(1 MPa = 10 bar = 147 PSI)

Termična dezinfekcija: maks. 70°C / 4 min

Zaščita proti povratnemu toku

Proizvod je zasnovan izključno za sanitarno vodo!

OPIS SIMBOLA



Ne smete uporabiti silikona, ki vsebuje osetno kislino!



VZDRŽEVANJE PROTIPOVRATNI VENTIL

(glejte stran 40)

Delovanje protipovratnega ventila je potrebno v skladu z DIN EN 1717 in skladno z državnimi in regionalnimi določili redno testirati (najmanj enkrat letno).

VZDRŽEVANJE SECUFLEX GIBKA CEV

(glejte stran 40)

Izvlačno prho ponovno očistite, če jo je težko izvleči.



MERE (glejte stran 37)



REZERVNI DELI (glejte stran 42)

XXX = Barve

000 = Krom

020 = Polished Chrome

130 = Polished Bronze

140 = Brushed Bronze

250 = Brushed Gold-Optic

260 = Brushed Chrome

300 = Polished Redgold

310 = Brushed Redgold

330 = Polished Black Chrome

340 = Brushed Black Chrome

800 = Stainless Steel Optic

820 = Brushed Nickel

830 = Polished Nickel

930 = Polished Brass

950 = Brushed Brass

990 = Polished Gold-Optic



ČIŠČENJE (glejte stran 38)



UPRAVLJANJE (glejte stran 39)

△ OHUTUSJUHISED

- △ Kandke paigaldamisel muljumis- ja löikevigastuste vältimiseks kindaid.
- △ Toodet tohib kasutada ainult pesemis-, hügieeni- ja kehapihustamisesmärgidel.
- △ Toodet ei tohi kasutada käepidemena. Paigaldage eraldi käepide.

PAIGALDAMISJUHISED

- / Enne paigaldamist tuleb toodet kontrollida transpordikahjustuste osas. Pärast paigaldamist ei tunnustata enam transpordi- või pinnakahjustuste kaebuseid.
- / Voolikute ja segisti paigaldamisel, loputamisel ja kontrollimisel tuleb lähtuda kehtivatest normatiividest.
- / Vastavas riigis kehtivaid paigalduseeskirju tuleb järgida.
- / Optimaalne funktsioneerimine on garanteeritud ainult koos Hansgrohe käsiduššide ja Hansgrohe dušivoolikutega.
- / Kui Secuflex-Box paigaldatakse valesti või üldse mitte, kaotab garantii kehtivuse.

TEHNILISED ANDMED

Äravoolu surve 0,3 MPa 24 l/min

(1 MPa = 10 baari = 147 PSI)

Termiline desinfitatsioon: maks. 70°C / 4 min

Tagasivoolklapp

Toode on ette nähtud eranditult joogivee jaoks!

SÜMBOLITE KIRJELDUS



Ärge kasutage äädikhapet sisaldavat silikoonil

HOOLDUS TAGASILÖÖGIKLAPP
(vt lk 40)

Tagasilöögi klappide toimimist tuleb kooskõlas riiklike ja regionaalsete määrustega regulaarselt kontrollida vastavalt standardile DIN EN 1717 (vähemalt kord aastas).

HOOLDUS SECUFLEX'I VOOLIK
(vt lk 40)

Puhastage uuesti, kui väljatõmbamine raskemaks muutub.

MÕÕTUDE (vt lk 37)



VARUOSAD (vt lk 42)

XXX = Värvid

000 = Kroom

020 = Polished Chrome

130 = Polished Bronze

140 = Brushed Bronze

250 = Brushed Gold-Optic

260 = Brushed Chrome

300 = Polished Redgold

310 = Brushed Redgold

330 = Polished Black Chrome

340 = Brushed Black Chrome

800 = Stainless Steel Optic

820 = Brushed Nickel

830 = Polished Nickel

930 = Polished Brass

950 = Brushed Brass

990 = Polished Gold-Optic



PUHASTAMINE (vt lk 38)

KASUTAMINE (vt lk 39)



△ DROŠĪBAS NORĀDES

- △ Montāžas laikā, lai izvairītos no saspiedumiem un iegriezumiem, nepieciešams nēsāt cimdus.
- △ Šo produktu drīkst izmantot tikai, lai mazgātos, higiēnai un ķermeņa tīrīšanai.
- △ Šo produktu nedrīkst izmantot kā roku balstu. Nepieciešams uzmontēt atsevišķu roku balstu.

NORĀDĪJUMI MONTĀŽAI

- / Pirms montāžas nepieciešams pārbaudīt, vai produktam transportēšanas laikā nav radušies bojājumi. Pēc iebūvēšanas bojājumi, kas radušies transportēšanas laikā, vai virsmas bojājumi netiek atzīti.
- / Caurulvadi un armatūra ir jāuzstāda, jāizskalo un jāpārbauda saskaņā ar spēkā esošajiem standartiem.
- / Jāievēro attiecīgās valstīs spēkā esošās montāžas prasības.
- / Optimāla funkcija tiek garantēta tikai kombinācijā ar Hansgrohe rokas dušām un Hansgrohe dušas šļūtenēm.
- / Ja Secuflex-Box ir montēta nepareizi vai nav montēta vispār, garantija zaudē spēku.

TEHNISKIE DATI

Brīva caurplūde, ja ir 0,3 MPa: 24 l/min
 (1 MPa = 10 bar = 147 PSI)

Termiskā dezinfekcija : maks. 70°C / 4 min

Drošības vārsts

Izstrādājums ir paredzēts tikai dzeramajam ūdenim!

SIMBOLU NOZĪME



Neizmantojot silikonu, kas satur etiķskābi!

APKOPE PRETVĀRSTS

(skat. lpp. 40)

Regulāri jāpārbauda pretvārsta funkcija saskaņā ar DIN EN 1717 saistībā ar nacionālajiem vai vietējiem noteikumiem (vismaz vienreiz gadā).

APKOPE SECUFLEX ŠĻŪTENE

(skat. lpp. 40)

Tīrīšana atkārtoti, ja laika gaitā izvilksana kļūst apgrūtināta.



IZMĒRUS (skat. lpp. 37)



REZERVES DAĻAS (skat. lpp. 42)

XXX = Krāsu kodi
 000 = Hroma
 020 = Polished Chrome
 130 = Polished Bronze
 140 = Brushed Bronze
 250 = Brushed Gold-Optic
 260 = Brushed Chrome
 300 = Polished Redgold
 310 = Brushed Redgold
 330 = Polished Black Chrome
 340 = Brushed Black Chrome
 800 = Stainless Steel Optic
 820 = Brushed Nickel
 830 = Polished Nickel
 930 = Polished Brass
 950 = Brushed Brass
 990 = Polished Gold-Optic



TĪRĪŠANA (skat. lpp. 38)



LIETOŠANA (skat. lpp. 39)



△ SIGURNOSNE NAPOMENE

- △ Prilikom montaže se radi sprečavanja prignječenja i posekotina moraju nositi rukavice.
- △ Proizvod sme da se koristi samo za kupanje, tuširanje i ličnu higijenu.
- △ Proizvod se ne sme koristiti za kao ručka za pridržavanje. U tu svrhu se mora postaviti zaseban rukohvat.

INSTRUKCIJE ZA MONTAŽU

- / Pre montaže se mora proveriti da li je proizvod oštećen pri transportu. Nakon ugradnje se ne priznaju nikakve reklamacije koje se odnose na površinska i transportna oštećenja.
- / Vodovi i armatura moraju biti postavljeni, isprani i testirani prema važećim normama.
- / Treba se pridržavati propisa koji u određenim zemljama važe za instalacije.
- / Optimalno funkcionisanje je garantovano jedino u kombinaciji sa Hansgrohe ručnim tuševima i Hansgrohe crevom za tuš.
- / Ako se Secuflex-Box pogrešno ili uopšte ne instalira, gubi se pravo na reklamacije.

TEHNIČKI PODACI

Slobodan protok na 0,3 MPa: 24 l/min

(1 MPa = 10 bar = 147 PSI)

Termička dezinfekcija: maks. 70°C / 4 min

Zaštita od povratnog toka

Proizvod je koncipiran isključivo za pijaću vodu!

OPIS SIMBOLA



Nemojte koristiti silikon koji sadrži sirćetnu kiselinu!



ODRŽAVANJE NEPOVRATNI VENTIL

(vidi stranu 40)

Ispravno funkcionisanje nepovratnog ventila se mora redovno proveravati prema standardu DIN EN 1717 i u skladu s važećim nacionalnim ili regionalnim propisima (najmanje jednom godišnje).

ODRŽAVANJE SECUFLEX CREVO

(vidi stranu 40)

Ukoliko nakon nekog vremena voda i dalje slabo ističe, ponovite čišćenje.



MERE (vidi stranu 37)



REZERVNI DELOVI (vidi stranu 42)

XXX = Oznake boja

000 = Hrom

020 = Polished Chrome

130 = Polished Bronze

140 = Brushed Bronze

250 = Brushed Gold-Optic

260 = Brushed Chrome

300 = Polished Redgold

310 = Brushed Redgold

330 = Polished Black Chrome

340 = Brushed Black Chrome

800 = Stainless Steel Optic

820 = Brushed Nickel

830 = Polished Nickel

930 = Polished Brass

950 = Brushed Brass

990 = Polished Gold-Optic



ČIŠĆENJE (vidi stranu 38)



RUKOVANJE (vidi stranu 39)

△ SIKKERHETSHENVISNINGER

- △ Bruk hansker under montasjen for å unngå klem- og kuttskader.
- △ Produktet skal kun brukes for bade-, hygiene- og kroppshygiene.
- △ Produktet skal ikke brukes som holdegrep. Det skal monteres en separat holdegrep.

MONTAGEHENVISNINGER

- / Før montasjen skal produktet sjekkes for transportskader. Etter monteringen aksepteres ikke noen transport- eller overflateskader.
- / Ledningene og armaturen skal monteres, spyles og sjekkes iht. de gyldige normer.
- / Gjeldende retningslinjer for rørleggerarbeid i de enkelte land skal følges.
- / Optimal funksjon garanteres kun i forbindelse med Hansgrohe hånddušj og Hansgrohe dusjslanger.
- / Dersom Secuflex-boksen monteres feil eller ikke installers, bortfaller garantien.

TEKNISKE DATA

Fri gjennomstrømning ved 0,3 MPa: 24 l/min

(1 MPa = 10 bar = 147 PSI)

Termisk desinfisering: maks. 70°C/4 min

Egensikker mot tilbakeflyt

Produktet er utelukkende designet for drikkevann!

SYMBOLBESKRIVELSE



Ikke bruk silikon som inneholder eddiksyre!



VEDLIKEHOLD RETURLØPSSPERRE

(se side 40)

Funksjonen til returløpssperren skal iht. DIN EN 1717 og i samsvar med de nasjonale og lokale forskrifter sjekkes regelmessig (minst en gang i året).

VEDLIKEHOLD SECUFLEX SLAN-GE

(se side 40)

Gjenta rengjøringen hvis det er vanskelig å ta ut uttrekkeren .



MÅL (se side 37)



SERVICEDELER (se side 42)

XXX = Fargekode

000 = Krom

020 = Polished Chrome

130 = Polished Bronze

140 = Brushed Bronze

250 = Brushed Gold-Optic

260 = Brushed Chrome

300 = Polished Redgold

310 = Brushed Redgold

330 = Polished Black Chrome

340 = Brushed Black Chrome

800 = Stainless Steel Optic

820 = Brushed Nickel

830 = Polished Nickel

930 = Polished Brass

950 = Brushed Brass

990 = Polished Gold-Optic



RENGJØRING (se side 38)



BETJENING (se side 39)



⚠ УКАЗАНИЯ ЗА БЕЗОПАСНОСТ

- ⚠ При монтажа трябва да се носят ръкавици, за да се избегнат наранявания поради притискане или порязване.
- ⚠ Позволено е използването на продукта само за къпане, хигиена и цели на почистване на тялото.
- ⚠ Продуктът не бива да се използва като дръжка. Трябва да се монтира отделна дръжка.

УКАЗАНИЯ ЗА МОНТАЖ

- / Преди монтажа продуктът трябва да се провери за транспортни щети. След монтажа не се признават транспортни или повърхностни щети.
- / Тръбопроводите и арматурата трябва да се монтира, промият и проверят в съответствие с валидните норми.
- / Трябва да бъдат спазвани валидните в съответните страни предписания за инсталиране.
- / Оптималното функциониране се гарантира само във връзка с ръчните разпръскватели и маркучите на разпръскватели на Hansgrohe.
- / Ако Secuflex-Vox бъде инсталирана неправилно или не бъде инсталирана, се губи гаранцията.

ТЕХНИЧЕСКИ ДАННИ

Свободен поток при 0,3 МПа: 24 л/мин
(1 МПа = 10 bar = 147 PSI)

Термична дезинфекция: макс. 70°C / 4 мин

Самозащитен против обратно изтичане

Продуктът е разработен само за питейна вода!

ОПИСАНИЕ НА СИМВОЛИТЕ



Не използвайте силикон, съдържащ оцетна киселина!



ПОДДРЪЖКА ПРИСПОСОБЛЕНИЕ, ПРЕДОТВРЯВАЩО ОБРАТНИЯ ПОТОК

(вижте стр. 40)

Съгласно DIN EN 1717 функционирането на приспособленията за предотвратяване на обратния поток трябва редовно да се проверява в съответствие с националните или регионалните изисквания (поне веднъж годишно).

ПОДДРЪЖКА МАРКУЧ SECUFLEX

(вижте стр. 40)

Повторете почистването, ако в течение на времето изтеглящата се част стане трудно подвижна.



РАЗМЕРИ (вижте стр. 37)



СЕРВИЗНИ ЧАСТИ (вижте стр. 42)

XXX = Цветово кодиране
000 = Хром
020 = Polished Chrome
130 = Polished Bronze
140 = Brushed Bronze
250 = Brushed Gold-Optic
260 = Brushed Chrome
300 = Polished Redgold
310 = Brushed Redgold
330 = Polished Black Chrome
340 = Brushed Black Chrome
800 = Stainless Steel Optic
820 = Brushed Nickel
830 = Polished Nickel
930 = Polished Brass
950 = Brushed Brass
990 = Polished Gold-Optic



ПОЧИСТВАНЕ (вижте стр. 38)



ОБСЛУЖВАНЕ (вижте стр. 39)

△ UDHËZIME SIGURIE

- △ Për të evituar lëndimet e pickimeve ose të prerjeve gjatë procesit të montimit duhet që të vishni doreza.
- △ Produkti duhet të përdoret vetëm qëllimet e banjave, të higijenës dhe të larjes së trupit.
- △ Produkti nuk duhet të përdoret si dorëze mbajtëse. Duhet të montohet një dorëzë mbajtëse e veçantë

UDHËZIME PËR MONTIMIN

- / Përpara montimit duhet që produkti të kontrollohet për dëmtime nga transporti. Pas instalimit nuk do të njihet asnjë dëmtim nga transporti ose dëmtim i sipërfaqes.
- / Tubacionet dhe rubinetet duhet që të montohen, të shpëlahen dhe të kontrollohen sipas standardeve në fuqi
- / Duhet të respektohen linjat udhëzuese të instalimit, të vlefshme për vendet respektive.
- / Garantohe funksioni optimal vetëm në kombinim me spërkatëset Hansgrohe si dhe zorrat e dushit Hansgrohe.
- / Nëse Secuflex-Box u instalua në mëyrë të gabuar ose nuk u instalua fare, atëherë humbet garancia.

TË DHËNA TEKNIKE

Rrjedhja e lirë me 0,3 Mpa: 24 l/min

(1 MPa = 10 bar = 147 PSI)

Dezinfektim Termik: maks. 70°C/4 min

Siguresa kundër rrjedhjes në drejtim të kundërt

Produkti është projektuar ekskluzivisht për ujë të pijshëm!

PËRSHKRIMI I SIMBOLIT



Mos përdorni silikon që në përbërje ka acid acetik.



MIRËMBAJTJA PENGUESI I RRJEDHJES NË DREJTIM TË KUNDËRT

(shih faqen 40)

Penguesit e rrjedhjes në drejtim të kundërt duhen kontrolluar rregullisht në bazë të normave DIN EN 1717 konform normave nacionale dhe regionale (së paku një herë në vit).

MIRËMBAJTJA ZORRA SECUFLEX

(shih faqen 40)

Përsërisni pastrimin nëse me kalimin e kohës vështrësohet nxjerrja e dorëzës së zgjatur.



PËRMASAT (shih faqen 37)



PJESËT E SERVISIT (shih faqen 42)

XXX = Kodimi me anë të ngjyrave

000 = Krom

020 = Polished Chrome

130 = Polished Bronze

140 = Brushed Bronze

250 = Brushed Gold-Optic

260 = Brushed Chrome

300 = Polished Redgold

310 = Brushed Redgold

330 = Polished Black Chrome

340 = Brushed Black Chrome

800 = Stainless Steel Optic

820 = Brushed Nickel

830 = Polished Nickel

930 = Polished Brass

950 = Brushed Brass

990 = Polished Gold-Optic



PASTRIMI (shih faqen 38)



PËRDORIMI (shih faqen 39)



وصف الرمز

هام! لا تستخدم السليكون الذي يحتوي على أحماض!



الصيانة صمام عدم الرجوع
(راجع صفحة 40)



يجب فحص صمام عدم الرجوع بصفة منتظمة حسب المواصفة DIN EN 1717 وذلك طبقاً للوائح الوطنية أو الإقليمية (مرة واحد سنوياً على الأقل).

الصيانة خرطوم Secuflex
(راجع صفحة 40)

كرر التنظيف كلما تعذر خروج الماء.

أبعاد (راجع صفحة 37)



قطع الغيار (راجع صفحة 42)



الألوان = XXX

كروم = 000

Polished Chrome = 020

Polished Bronze = 130

Brushed Bronze = 140

Brushed Gold-Optic = 250

Brushed Chrome = 260

Polished Redgold = 300

Brushed Redgold = 310

Polished Black Chrome = 330

Brushed Black Chrome = 340

Stainless Steel Optic = 800

Brushed Nickel = 820

Polished Nickel = 830

Polished Brass = 930

Brushed Brass = 950

Polished Gold-Optic = 990

التنظيف (راجع صفحة 38)



التشغيل (راجع صفحة 39)



تنبيهات الأمان

⚠ يجب إرتداء قفازات الليد أثناء التركيب لتجنب حدوث أضرار الإنحشار أو الجروح

⚠ لا يجب استخدام المنتج إلا في أغراض الاستحمام والأغراض الصحية وأغراض تنظيف الجسم.

⚠ ممنوع إستخدام المنتج كمقبض. يجب تركيب مقبض منفصل.

تعليمات التركيب

/ قبل القيام بعملية التركيب، يجب فحص المنتج للتأكد من خلوه من أية تلفيات ناتجة عن النقل بعد القيام بعملية التركيب، لن يتم الاعتراف بوجود أية تلفيات سطحية أو تلفيات ناتجة عن عملية النقل.

/ يجب تركيب وغسيل واختبار التوصيلات وخلاطات المياه طبقاً للمعايير السارية.

/ يجب مراعاة القواعد الخاصة بالتركيب وأعمال السباكة وفقاً للوائح الخاصة بكل بلد.

/ لا يمكن ضمان الحصول على الأداء الأمثل إلا من خلال الجمع بين الدش اليدوي إنتاج هانزجرهه وخرطوم الدش إنتاج هانزجرهه.

/ لا يسري الضمان في حالة تركيب Secuflex-Box بشكل خاطئ أو في حالة عدم تركيبه.

المواصفات الفنية

معدل تدفق 0,3 ميجابسكال: 24 لتر / الدقيقة

(1 ميجابسكال = 10 بار = 147 PSI)

تعقيم حراري: الحد الأقصى 4/70°C الدقيقة

خاصية عدم التدفق العكسي

المنتج مخصص فقط لماء الشرب!



△ BIZTONSÁGI UTASÍTÁSOK

- △ A szerelésnél a zúzódások és vágási sérülések elkerülése érdekében kesztyűt kell viselni.
- △ A terméket csak fürdéshez, mosakodáshoz, és egészségügyi tisztálkodáshoz szabad használni.
- △ A terméket nem szabad kapaszkodónak használni. Ehhez külön kapaszkodót kell felszerelni.

SZERELÉSI UTASÍTÁSOK

- / A szerelés előtt ellenőrizni kell, hogy a terméknek nincs-e szállítási sérülése. Beépítés után a szállítási- vagy felületi sérüléseket nem ismerik el.
- / A vezetékeket és a csaptelepet az érvényes szabványoknak megfelelően kell felszerelni, öblíteni és ellenőrizni
- / Az egyes országokban érvényes installációs irányelveket be kell tartani.
- / A megfelelő működést csak Hansgrohe kézizuhanyokkal és Hansgrohe zuhanycsövekkel garantáljuk.
- / Ha a Secuflex-Boxot rosszul vagy nem szerelik fel, akkor a jótállás érvényét veszti.

MŰSZAKI ADATOK

Szabad átfolyás 0,3 MPa nyomás esetén: 24 l/perc
(1 MPa = 10 bar = 147 PSI)

Termikus fertőtlenítés: max. 70°C/4 perc

Visszafolyás gátlóval

A terméket kizárólag ivóvízhez tervezték!

SZIMBÓLUMOK LEÍRÁSA



Ne használjon ecetsavtartalmú szilikon!

KARBANTARTÁS VISSZACsapószelep

(lásd a oldalon 40)

A visszafolyásgátlók működése a DIN EN 1717 szabványnak megfelelően, a nemzeti vagy területi rendelkezésekkel összhangban, évente egyszer ellenőrizendő!

KARBANTARTÁS SECUFLEX TÖMLŐ

(lásd a oldalon 40)

Ismételje meg a tisztítást, ha időközben elnehezül a kifolyás.



MÉRETET (lásd a oldalon 37)



TARTOZÉKOK (lásd a oldalon 42)

XXX = Színkódolás

000 = Króm

020 = Polished Chrome

130 = Polished Bronze

140 = Brushed Bronze

250 = Brushed Gold-Optic

260 = Brushed Chrome

300 = Polished Redgold

310 = Brushed Redgold

330 = Polished Black Chrome

340 = Brushed Black Chrome

800 = Stainless Steel Optic

820 = Brushed Nickel

830 = Polished Nickel

930 = Polished Brass

950 = Brushed Brass

990 = Polished Gold-Optic



TISZTÍTÁS (lásd a oldalon 38)



HASZNÁLAT (lásd a oldalon 39)



△ 安全上の注意

- △ 施工の際は手を挟んだり怪我をしないように、手袋をはめてください。
- △ この製品は、体や手を洗う等の製品本来の目的以外には使用しないでください。
- △ 製品は取っ手として使用できません。必要に応じて別途取っ手を設置してください。

施工上の注意

- ／ 製品の施工前に輸送でのダメージがないか確認してください。施工後のキズ等のお申し出はお断りさせていただきます。
- ／ 配管と水栓は、関連法規に従って施工、洗浄、および試験を行ってください。
- ／ 施工行う地域に適用される関連法規をお守りください。
- ／ ハンズグローエのハンドシャワーとシャワーホースとの組み合わせのみにおいて最適なお使用をいただけます。
- ／ セキュフレックス (Secuflex) ボックスの施工に問題がある場合や取り付けられていないときは、保証対象外となります。

技術資料

0.3 MPaで何も接続しない時の流量： 24 リットル分
(1 MPa = 10 bar = 147 PSI)

お湯による高温消毒： 最大 70°C / 4 分

逆流防止処置がされています

この製品は飲料水での使用が前提となっています (日本においては水道法に適合する飲料水) !

アイコンの説明



酢酸系シリコンをご使用にならないください!



メンテナンス 逆止弁

(次のページを参照 40)

逆止弁は、DIN EN 1717に従って定期的 (少なくとも年に1回) に確認をしてください (日本においては関連法規に従ってください)。

メンテナンス Secuflex ホース

(次のページを参照 40)

引き出しが硬くなったら、クリーニングを繰り返ししてください。



寸法 (次のページを参照 37)



スペアパーツ (次のページを参照 42)

XXX = 仕上げ色

000 = Chrome

020 = Polished Chrome

130 = Polished Bronze

140 = Brushed Bronze

250 = Brushed Gold-Optic

260 = Brushed Chrome

300 = Polished Redgold

310 = Brushed Redgold

330 = Polished Black Chrome

340 = Brushed Black Chrome

800 = Stainless Steel Optic

820 = Brushed Nickel

830 = Polished Nickel

930 = Polished Brass

950 = Brushed Brass

990 = Polished Gold-Optic



お手入れ方法 (次のページを参照 38)



使用方法 (次のページを参照 39)

施工方法 (次のページを参照 32)



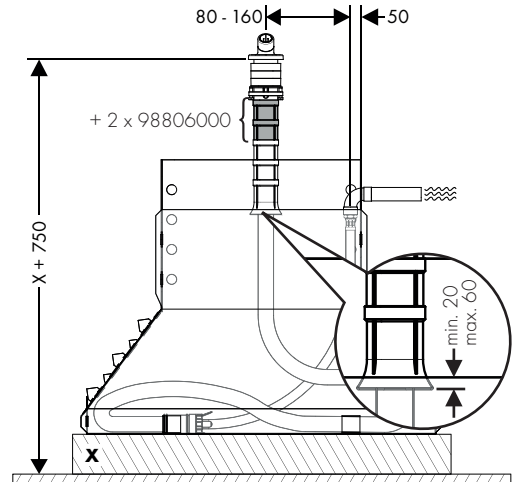
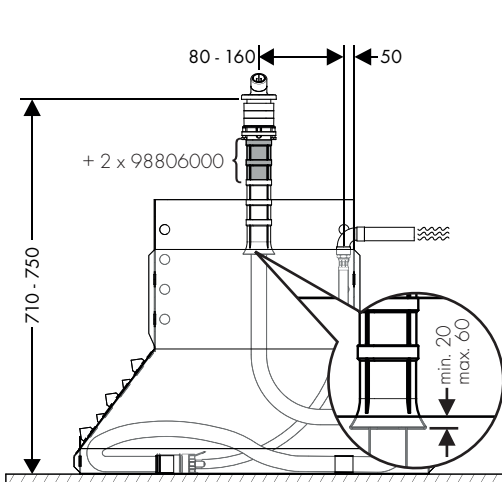
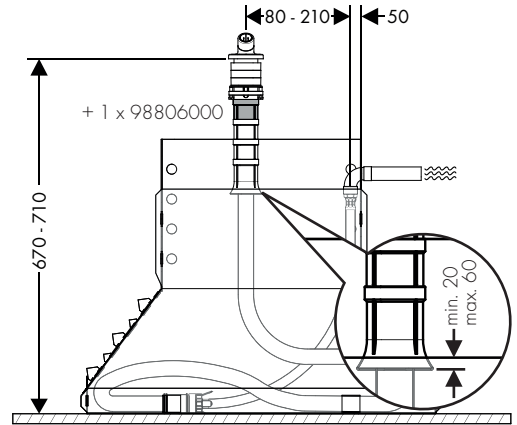
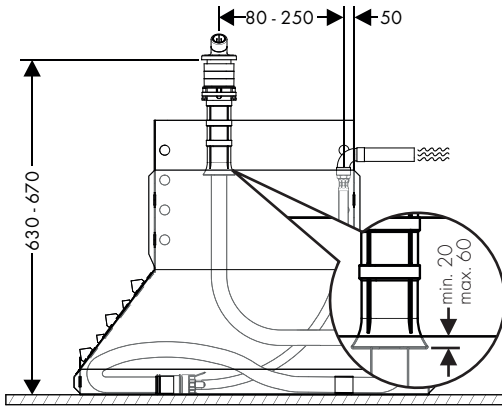
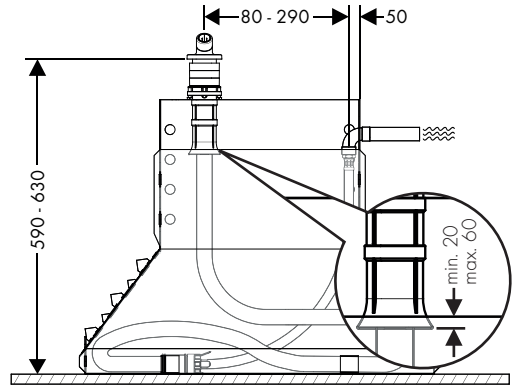
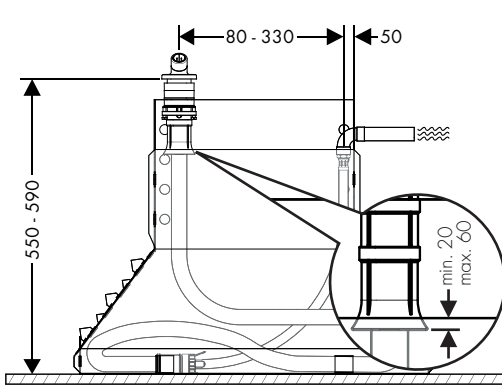

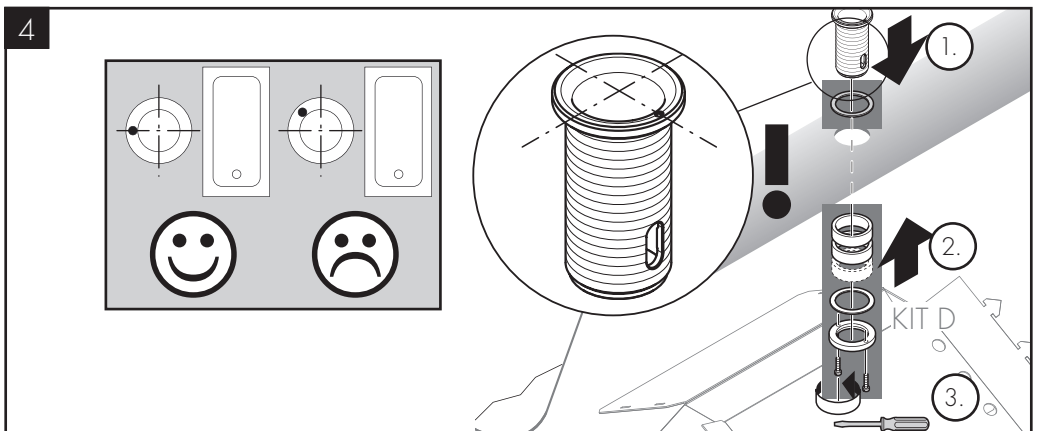
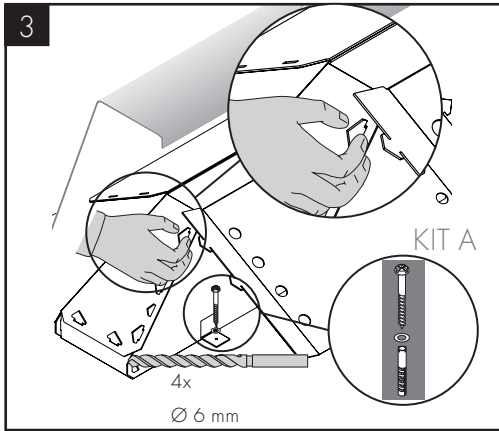
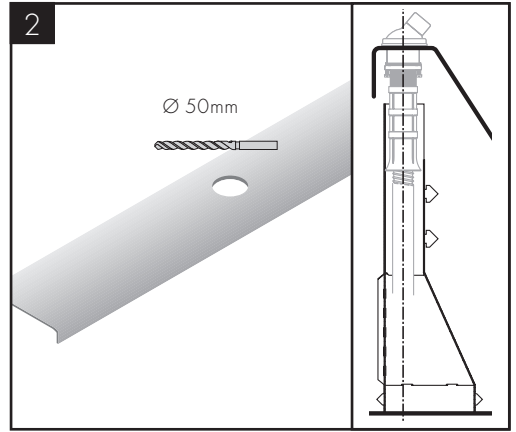
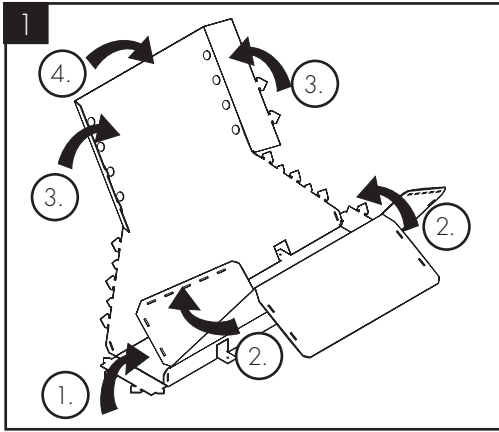

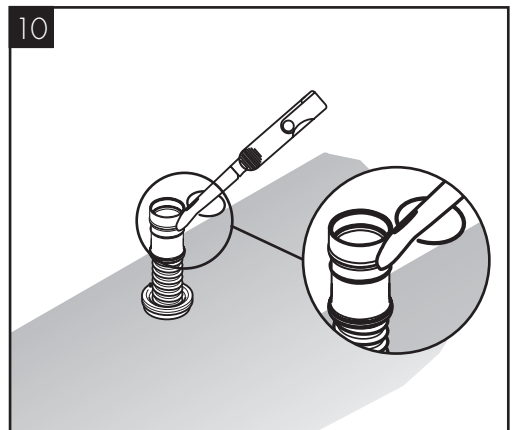
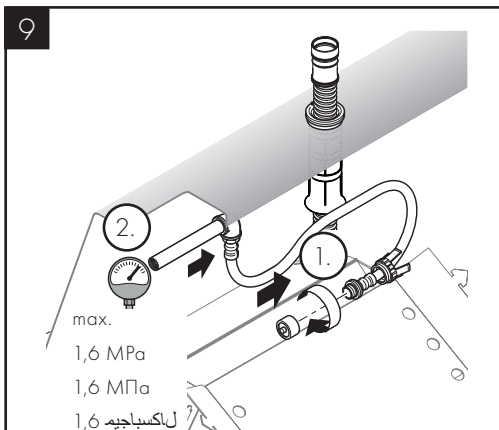
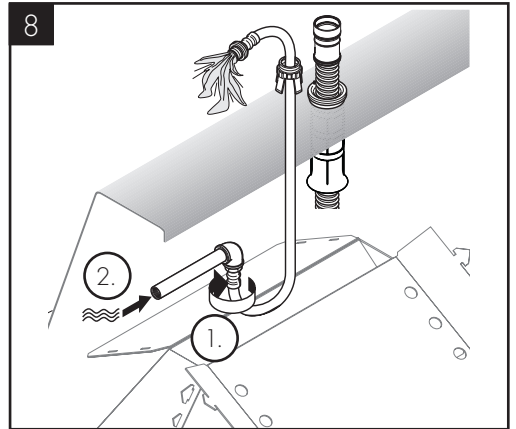
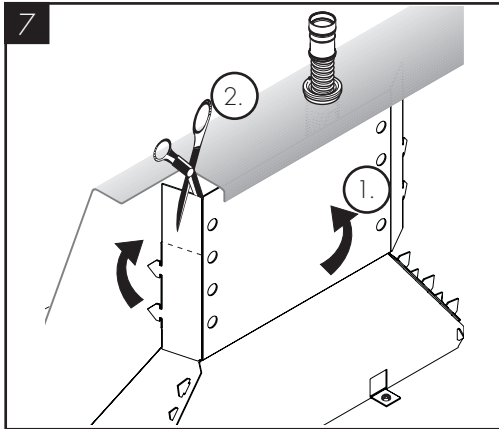
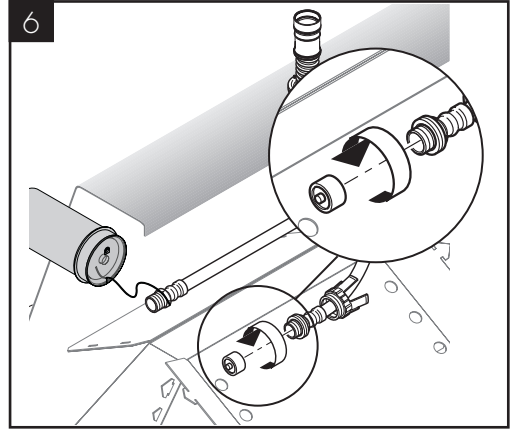
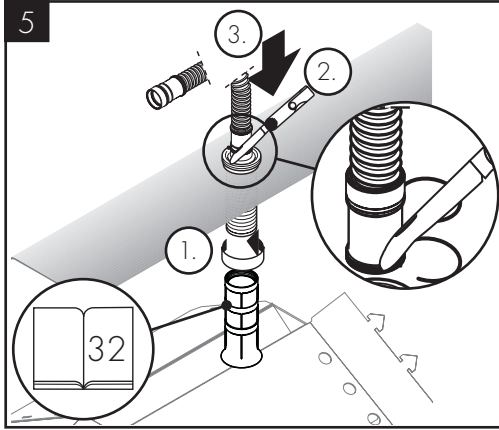

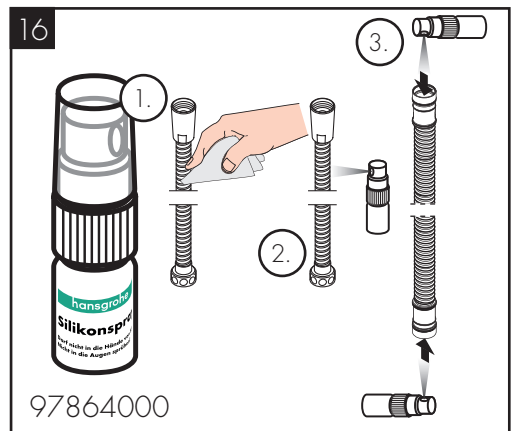
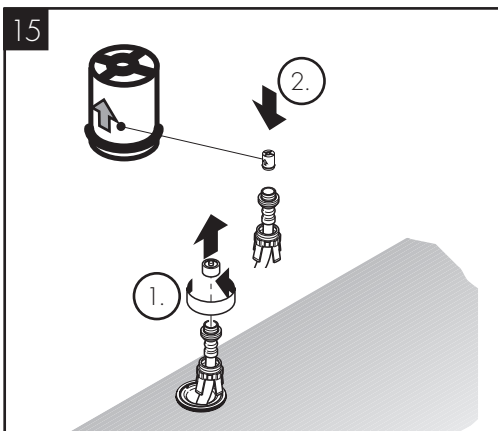
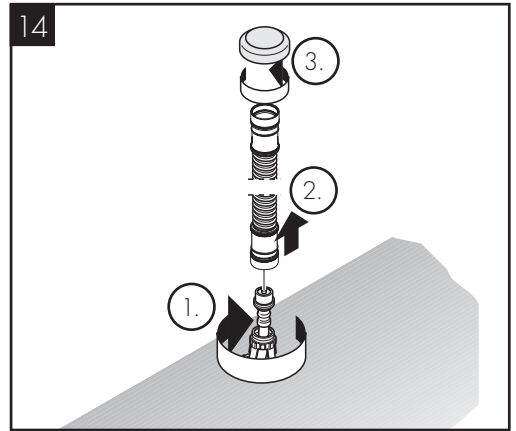
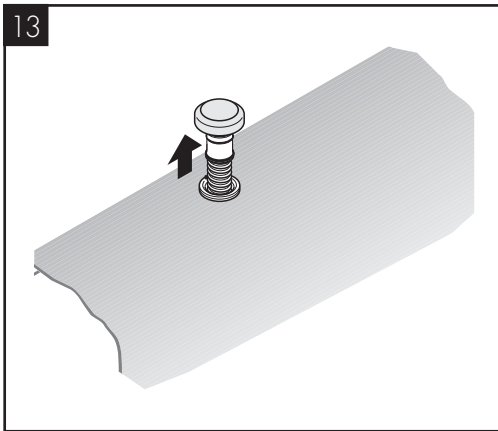
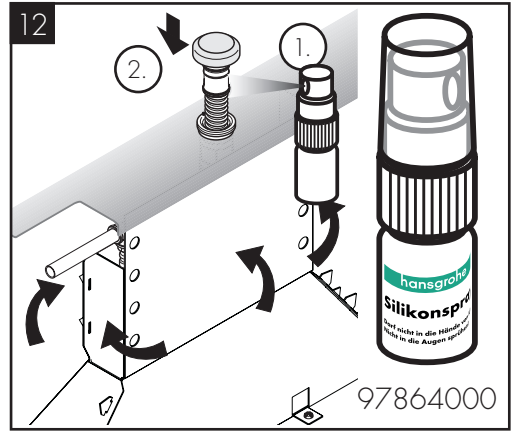
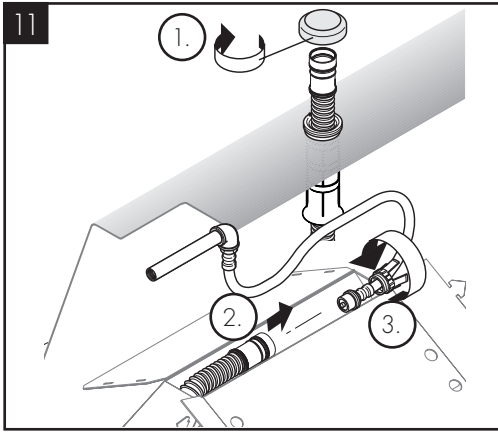

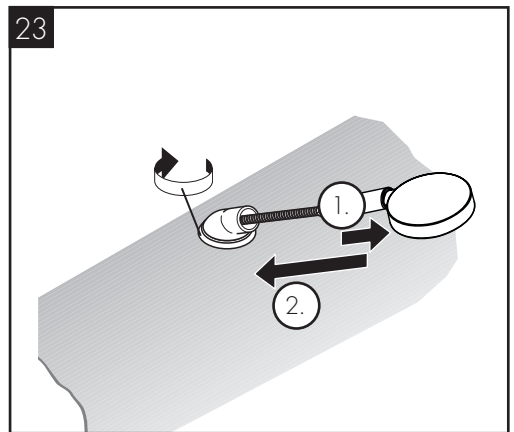
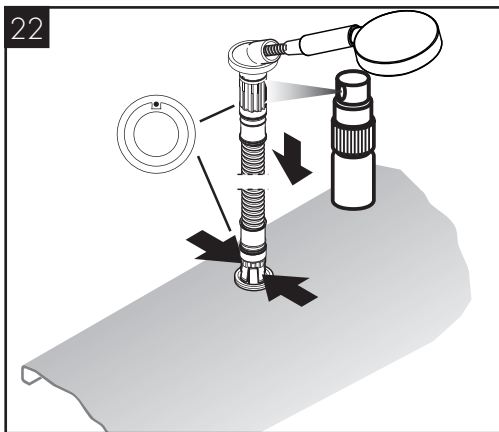
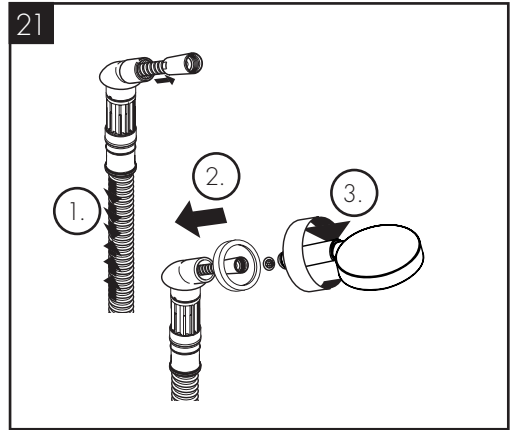
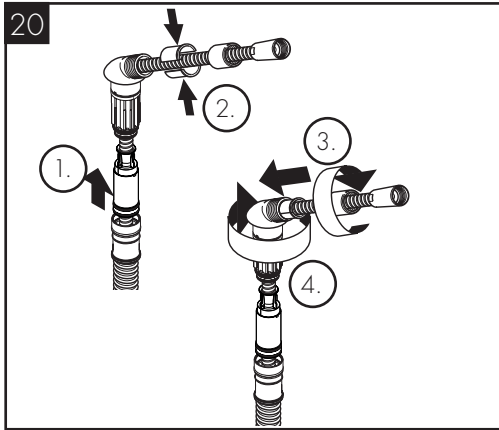
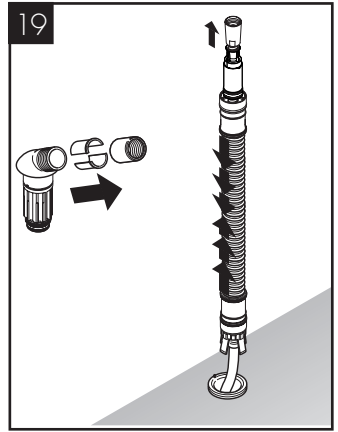
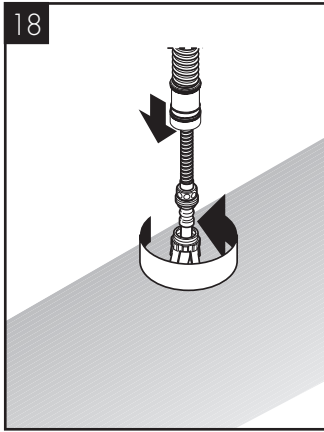
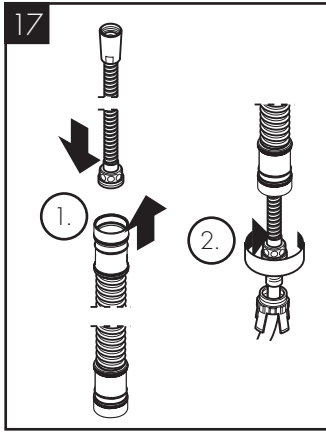

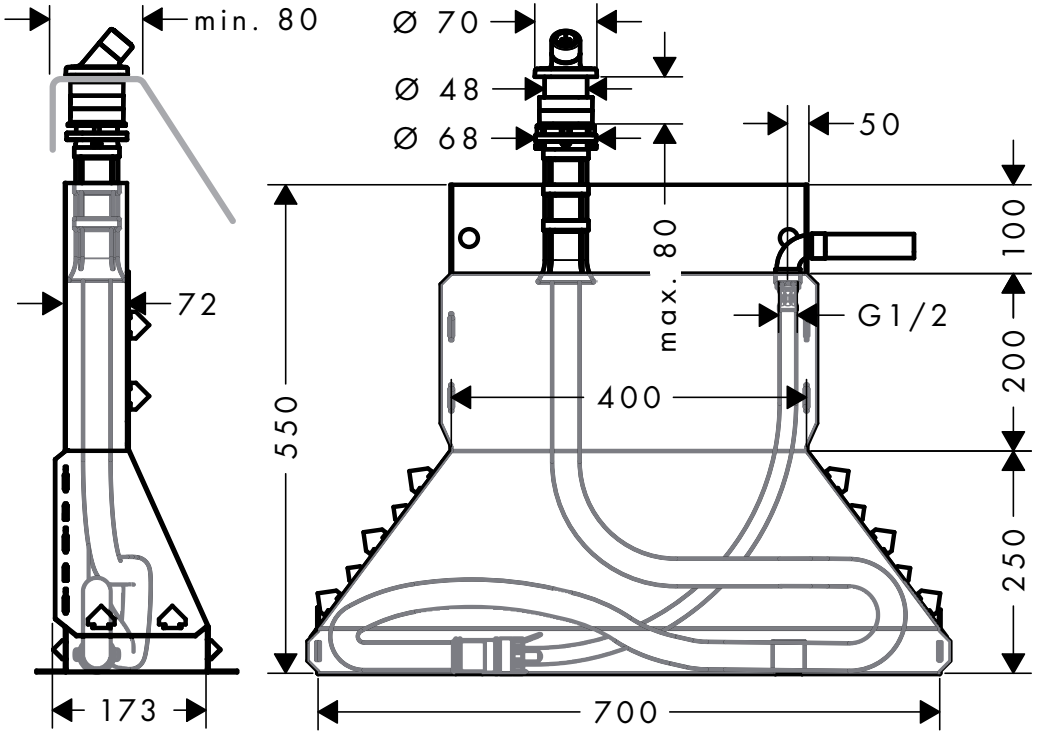



DE / Reinigungsempfehlung / Garantie / Kontakt
 FR / Recommandation pour le nettoyage / Garanties / Contact
 EN / Cleaning recommendation / Warranty / Contact
 IT / Raccomandazione di pulizia / Garanzia / Contatto
 ES / Recomendaciones para la limpieza / Garantía / Contacto
 NL / Aanbevelingen inzake reiniging / Garantie / Contact
 DK / Rensning, anbefaling / Garanti / Kontakt
 PT / Recomendações de limpeza / Garantia / Contacto
 PL / Zalecenie dotyczące pielęgnacji / Gwarancja / Kontakt
 CS / Doporučení k čištění / Záruka / Kontakt
 SK / Odporúčania pre čistenie / Záruka / Kontakt
 ZH / 清洁指南 / 担保 / 接触
 RU / Рекомендации по очистке / Гарантия / Контакты
 FI / Puhdistussuositus / Takuu / Kosketus
 SV / Rengöringsrekommendationer / Garanti / Contacto
 LT / Valymo rekomendacijos / Garantija / Kontaktai
 HR / Preporuke za čišćenje / Garancija / Kontakt
 TR / Temizleme önerisi / Garanti / Temas
 RO / Recomandări pentru curățare / Garanție / Contact
 EL / Σύσταση καθαρισμού / Εγγύηση / επαφή
 SL / Priporočilo za čiščenje / Garancija / Kontakt
 ET / Puhastussuovitused / Garantii / Kontakt
 LV / Tīrīšanas ieteikumi / Garantija / Kontakti
 SR / Preporuke za čišćenje / Garancija / Kontakt
 NO / Anbefaling for rengjøring / Garanti / Kontakt
 BG / Препоръка за почистване / Гаранция / Контакт
 SQ / Këshilla rreth pastrimit / Garancia / Kontakt
 KO / 세정시 권장사항 / 품질보증 / 접촉
 AR / توصيات التنظيف / الضمان (الولايات المتحدة الأمريكية) / اتصال
 HU / Tisztítási tanácsok / Garancia / érintkezés
 JP / お手入れの方法 / 保証について / ご連絡先



[www.axor-design.com/
cleaning-recommendation](http://www.axor-design.com/cleaning-recommendation)

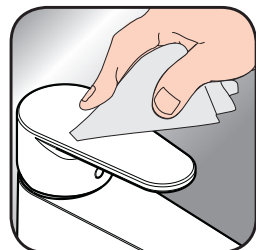

[www.axor-design.com/
cleaning-recommendation](http://www.axor-design.com/cleaning-recommendation)



[www.axor-design.com/
cleaning-recommendation](http://www.axor-design.com/cleaning-recommendation)



[www.axor-design.com/
cleaning-recommendation](http://www.axor-design.com/cleaning-recommendation)

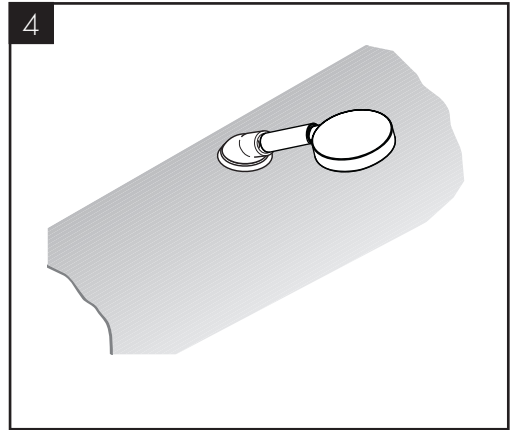
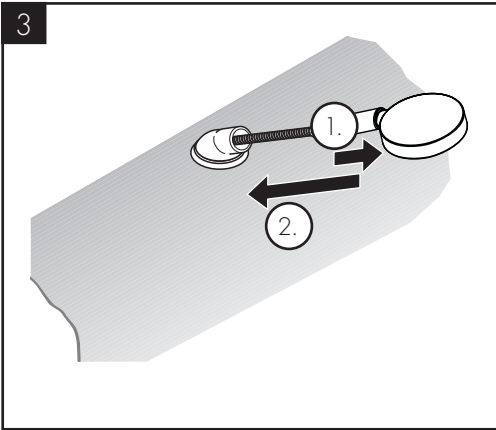
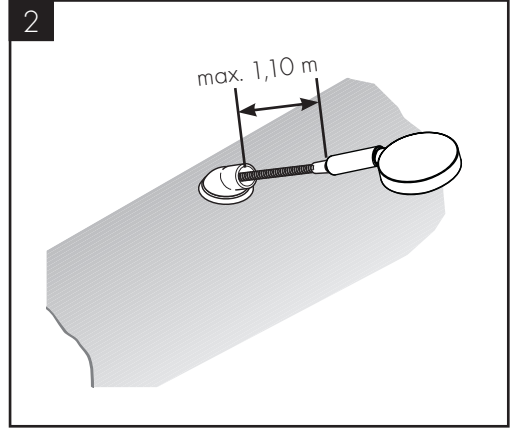
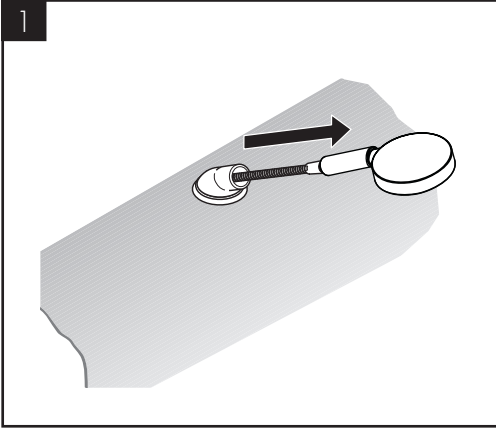

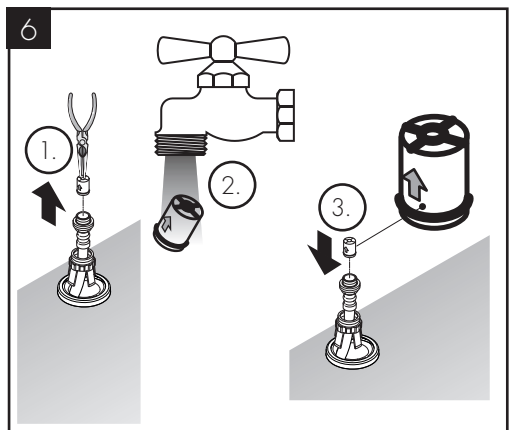
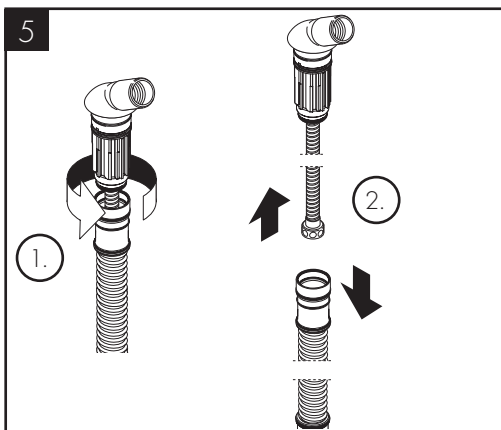
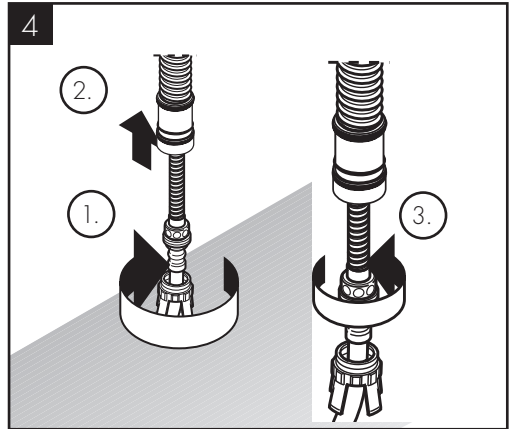
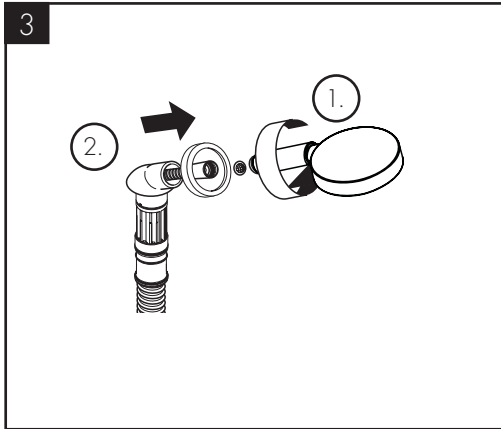
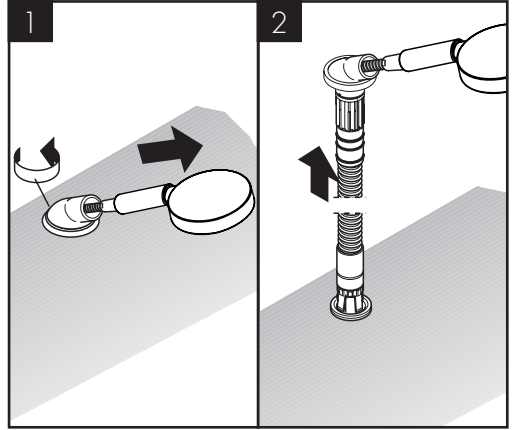
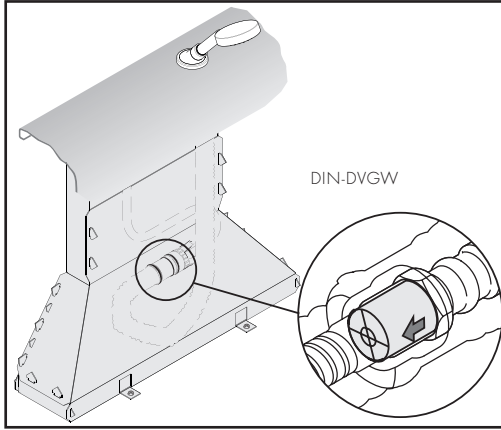

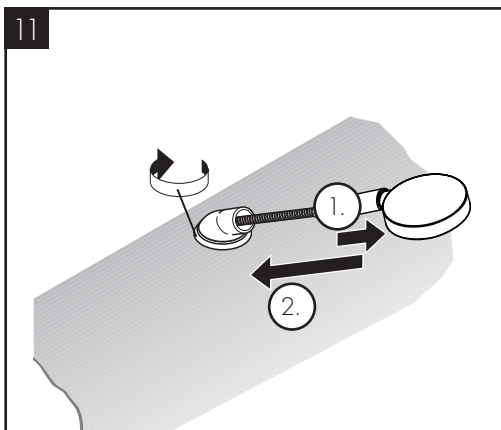
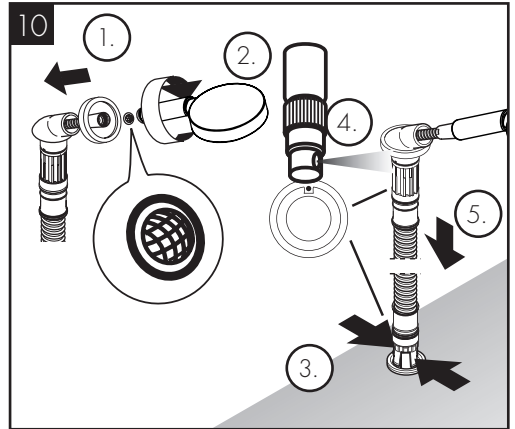
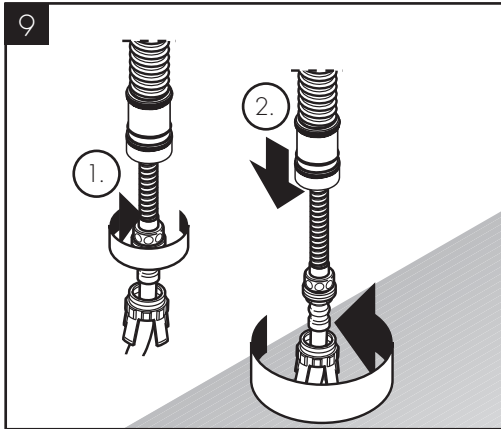
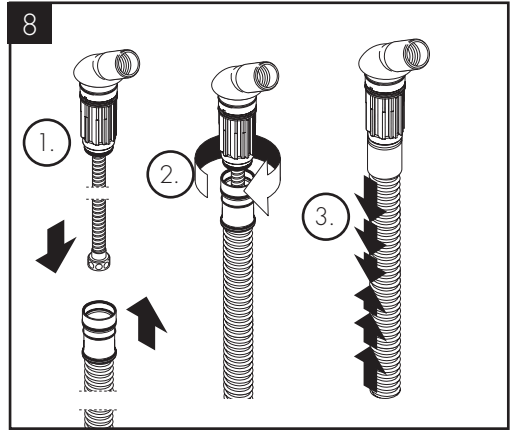
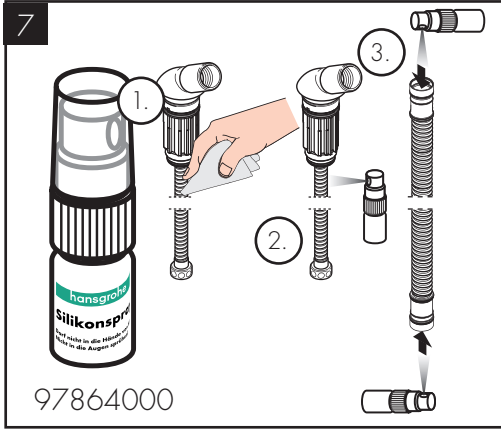

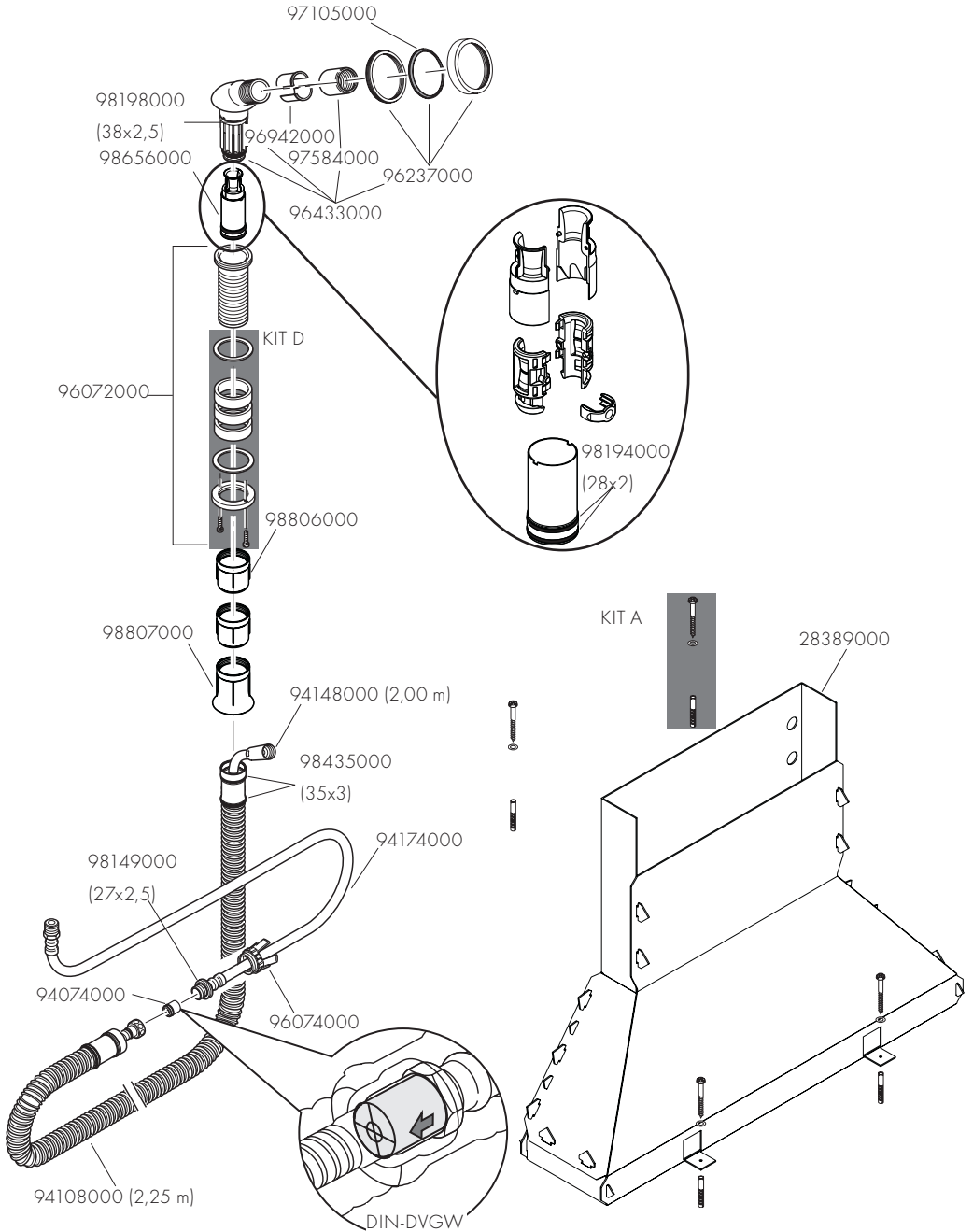

AXOR

AXOR / Hansgrohe SE
Austraße 5-9
77761 Schiltach
Deutschland

info@axor-design.com
axor-design.com

03/2020
91722701