

- EN** Installation / User Instructions / Warranty
- FR** Instructions de montage / Mode d'emploi / Garantie
- ES** Instrucciones de montaje / Manejo / Garantía

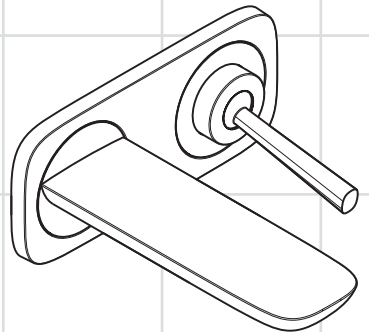

PuraVida
15085xx1

Technical Information

Recommended water pressure	15 - 75 PSI
Max. water pressure	145 PSI
Recommended hot water temp.	120° - 140° F*
Max. hot water temp	176° F*
Flow rate	1.2 GPM

*Please know and follow all applicable local plumbing codes when setting the temperature on the water heater.

Installation Considerations

- For best results, Hansgrohe recommends that this unit be installed by a licensed, professional plumber.
- Please read over these instructions thoroughly before beginning installation. Make sure that you have all tools and supplies needed to complete the installation.
- This trim is for use with rough 13622181 (not included).
- Keep this booklet and the receipt (or other proof of date and place of purchase) for this product in a safe place. The receipt is required should it be necessary to request warranty parts.

Données techniques

Pression d'eau recommandée	15 - 75 PSI
Pression d'eau maximum	145 PSI
Température recommandée d'eau chaude	120° - 140° F*
Température maximum d'eau chaude	176° F*
Capacité nominale	1.2 GPM

* Vous devez connaître et respecter tous les codes de plomberie locaux applicables pour le réglage de la température du chauffe-eau.

À prendre en considération pour l'installation

- Pour de meilleurs résultats, Hansgrohe recommande que ce produit soit installé par un plombier professionnel licencié.
- Veuillez lire attentivement ces instructions avant de procéder à l'installation. Assurez-vous de disposer de tous les outils et du matériel nécessaires pour l'installation.
- Ce dispositif requiert une pièce intérieure 13622181 (pas d'inclus).
- Conservez ce livret et le reçu (ou une autre preuve sur laquelle figurent la date et l'endroit de l'achat) pour ce produit dans un endroit sûr. Le reçu est requis si vous commandez des pièces sous garantie.

Datos técnicos

Presión recomendada en servicio	15 - 75 PSI
Presión en servicio max.	145 PSI
Temperatura recomendada del agua caliente	120° - 140° F*
Temperatura del agua caliente max.	176° F*
Caudal máximo	1.2 GPM

*Debe conocer y cumplir todos los códigos locales aplicables para ajustar la temperatura del calentador de agua.

Consideraciones para la instalación

- Para obtener mejores resultados, la instalación debe estar a cargo de un plomero profesional matriculado.
- Antes de comenzar la instalación, lea estas instrucciones detenidamente. Asegúrese de tener las herramientas y los insumos necesarios para completar la instalación.
- La unidad requiere una pieza interior de válvula 13622181.
- Mantenga este folleto y el recibo (u otro comprobante del lugar y fecha de compra) de este producto en lugar seguro. El recibo se requiere en caso de ser necesario solicitar piezas bajo garantía.

Tools Required / Outils Utiles / Herramientas Utiles

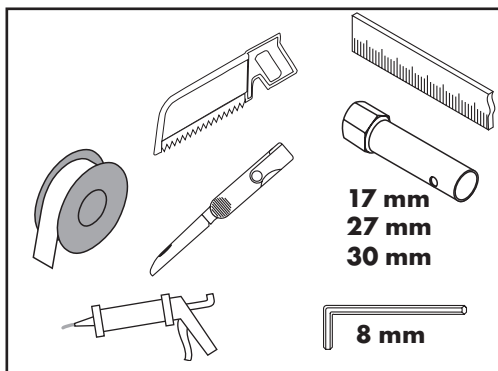

This unit meets or exceeds the following:

- ASME A112.18.1
- CSA B125.1
- Listed by IAPMO for use in the US and Canada
- WaterSense certified



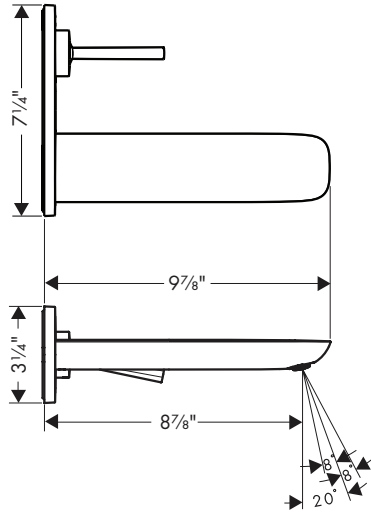

Suggested Installations / Suggestions d'installation / Sugerencias de instalación

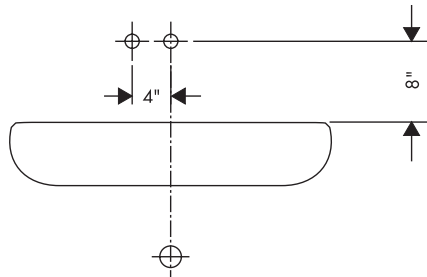
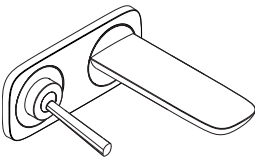
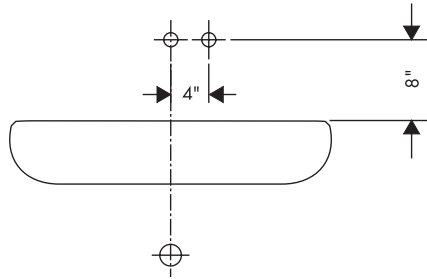
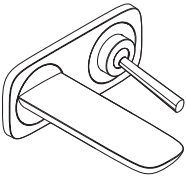

Installation / Installation / Instalación

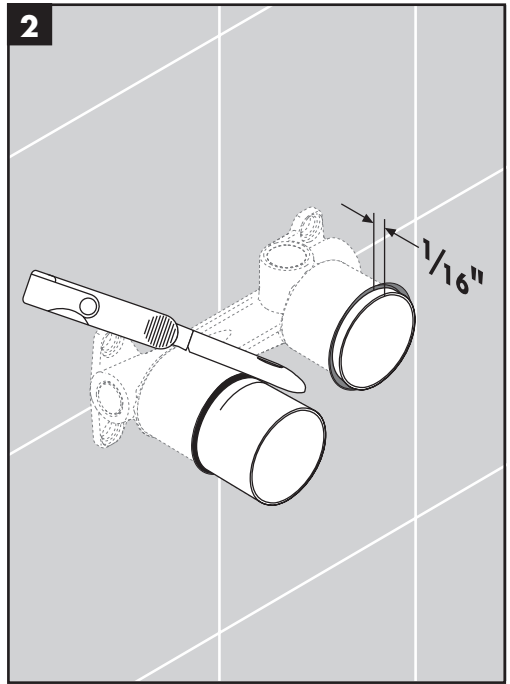
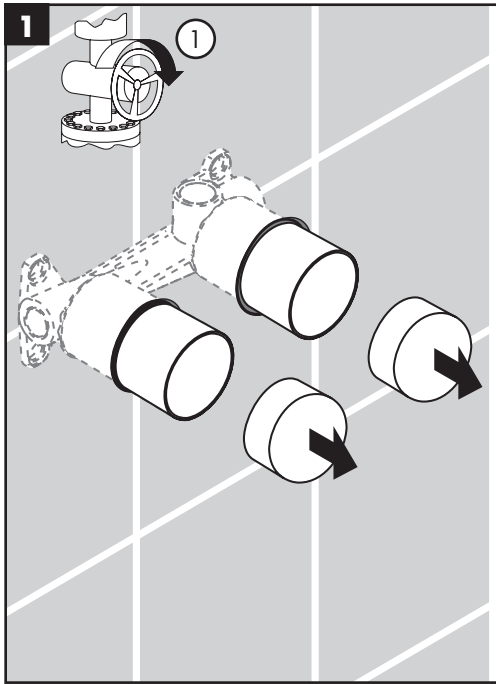

English

! Turn the water off at the main before proceeding.

Remove the caps.

Français

! Avant de commencer, fermez l'eau à la valve principale.

Retirez les capuchons.

Español

! Cierre el paso del agua en la entrada del suministro antes de comenzar.

Retire las tapas.

Cut the plaster shields so that they extend 1/16" outside the surface of the finished wall.

Coupez les protecteurs de façon à ce qu'une partie de 1/16 po soit à l'extérieur de la surface du mur fini.

Corte los protectores de yeso de modo que sobresalgan 1/16" de la superficie de la pared terminada.

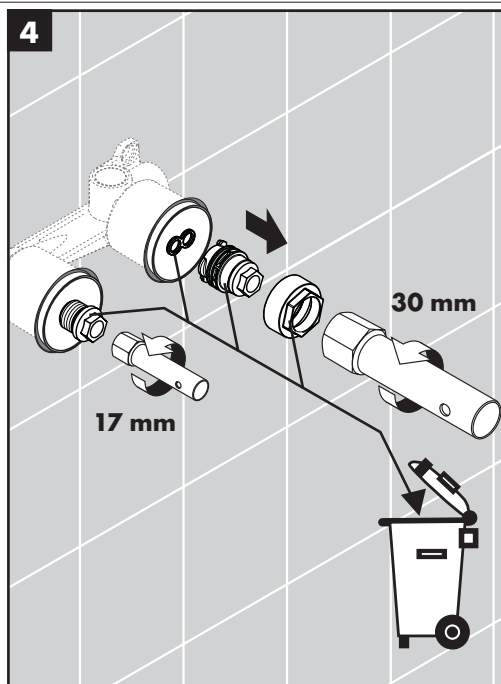
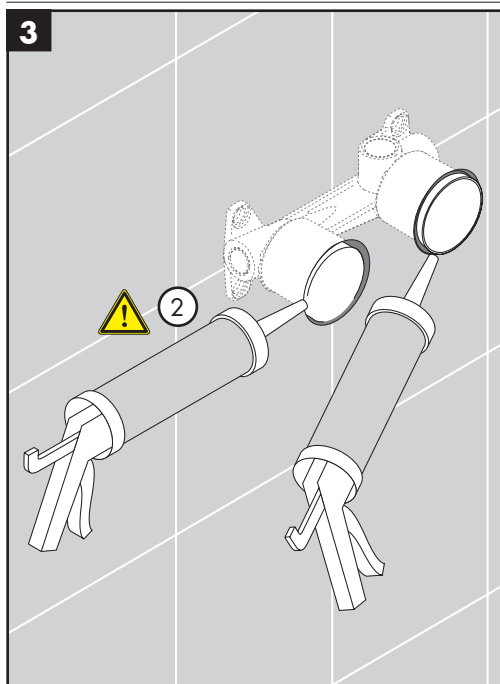

English

 **Seal the wall around the plaster shields using waterproof sealant.**

 **Failure to seal the wall can lead to possible water damage.**

Remove the plug from the spout port.

Remove the nut, flush insert, and sealing ring from the cartridge port.

Français

 **Scellez le mur autour des protecteurs à l'aide d'un agent d'étanchéité.**

 **Si le mur n'est pas scellé, l'eau pourrait éventuellement causer des dommages.**

Retirez le bouchon du port de bec de remplissage.

Retirez l'écrou, le compartiment affleurant et la bague d'étanchéité du port de cartouche.

Español

 **Selle la pared alrededor del protector de yeso con un sellador impermeable.**

 **Si no se sella la pared, pueden producirse daños por acción del agua.**

Retire el tapón del orificio del surtidor.

Retire la tuerca, el alojamiento de descarga y el anillo de sellado del orificio del cartucho.

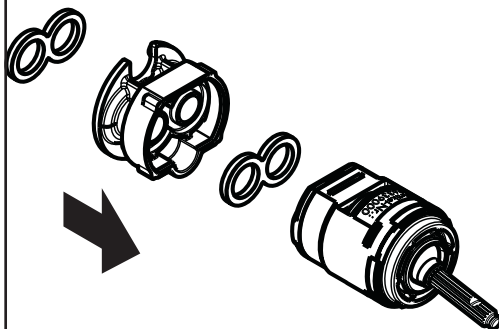
5**English**

Install the cartridge adapter and sealing rings on the cartridge.

Lightly lubricate the cartridge o-ring and joystick using white plumbers grease.

Insert the cartridge in the cartridge cover, oriented as shown on the diagram.

Français

Installez l'adaptateur et les bagues d'étanchéité dans la cartouche.

Lubrifiez légèrement la joint torique et le manche à balai en utilisant de la graisse de plomberie blanche.

Insérez la cartouche dans la couverture de cartouche selon l'illustration.

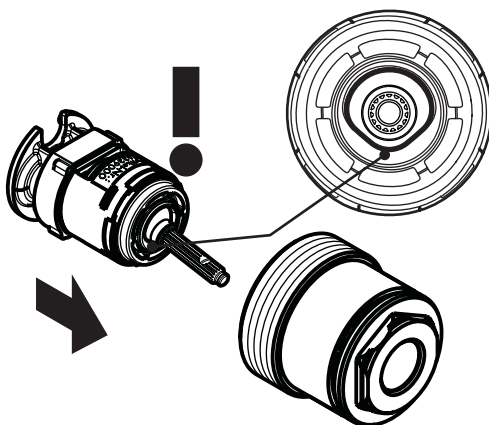
6**Español**

Instale el adaptador y las juntas en el cartucho.

Lubrique levemente la junta toroidal y la palanca de mando con grasa blanca para plomería.

Inserte el cartucho en la cobertura de cartucho, orientado como mostrado en el esquema.

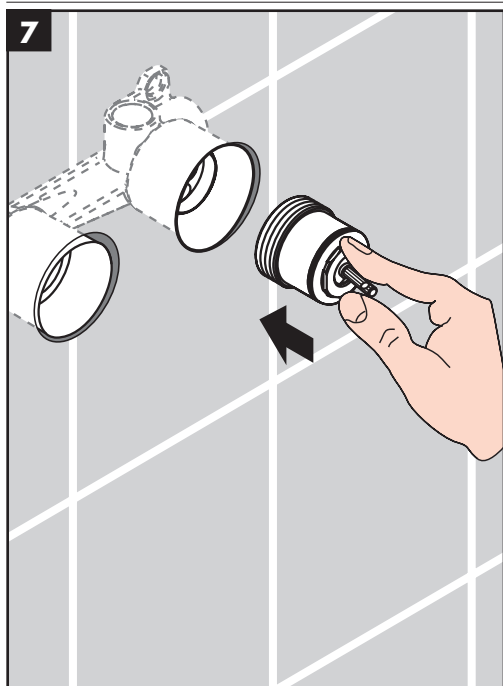

English

Install the cartridge.

Hold the cartridge stem steady with one hand.

With the other hand, rotate the cover clockwise to secure it to the rough.

Français

Installez la cartouche.

Tenez la cartouche en place avec une main.

Serrez le capot avec l'autre main.

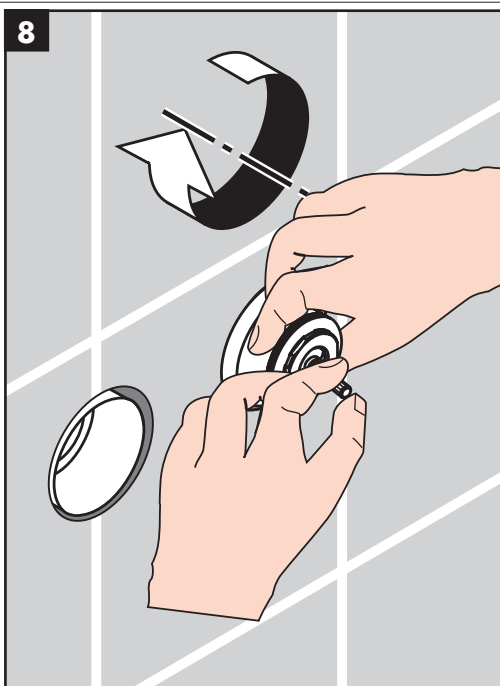

Español

Instale el cartucho.

Tenga el cartucho en el lugar con una mano.

Apriete la cobertura con la otra mano.

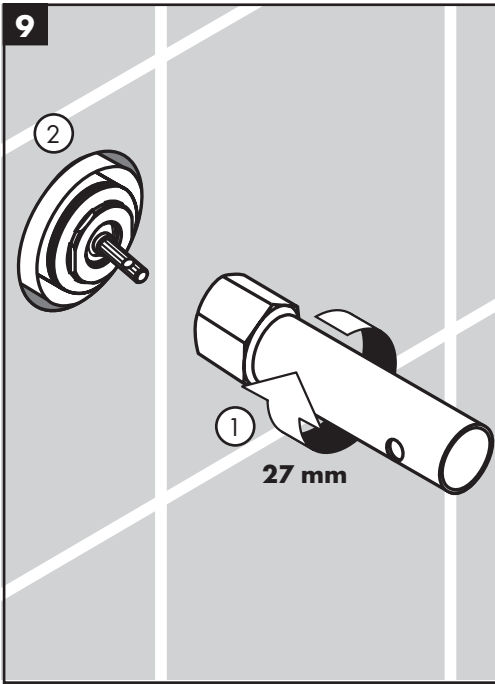

English

Tighten the cover using a 27 mm wrench.

Measure the distance between the wall and the edge of the cartridge stem.

If the distance measures $1\frac{1}{8}$ " - $1\frac{5}{8}$ ", select sleeves A.

If the distance measures $1\frac{5}{8}$ " - $1\frac{7}{8}$ " select sleeves B.

If the distance measures $1\frac{7}{8}$ " - $2\frac{1}{4}$ ", select sleeves C.

Français

Serrez la couverture à l'aide d'une clé de 27 mm.

Mesurez la distance entre le mur et le rebord de la cartouche.

Si la distance mesure de $1\frac{1}{8}$ - $1\frac{5}{8}$ po, sélectionnez les gaines A.

Si la distance mesure de $1\frac{5}{8}$ - $1\frac{7}{8}$ po, sélectionnez les gaines B.

Si la distance mesure de $1\frac{7}{8}$ - $2\frac{1}{4}$ po, sélectionnez les gaines C.

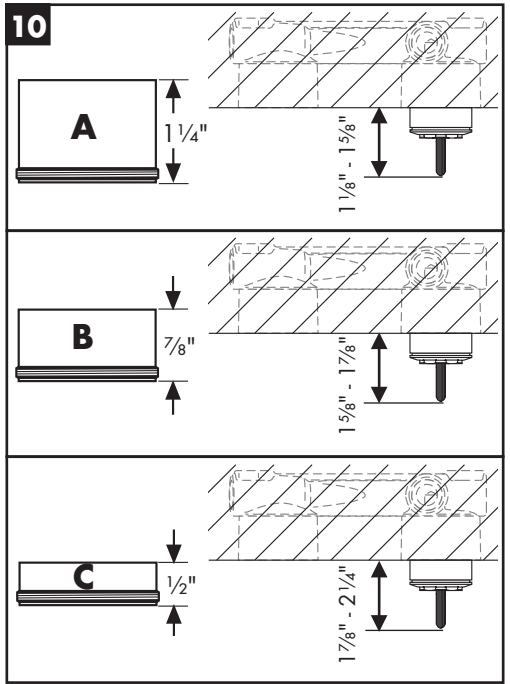

Español

Apriete la cobertura con una llave de 27 mm.

Mida la distancia entre la pared y el borde del cartucho.

Si la distancia es de $1\frac{1}{8}$ " - $1\frac{5}{8}$ ", seleccione los manguitos A.

Si la distancia es de $1\frac{5}{8}$ " - $1\frac{7}{8}$ ", seleccione los manguitos B.

Si la distancia es de $1\frac{7}{8}$ " - $2\frac{1}{4}$ ", seleccione los manguitos C.

11

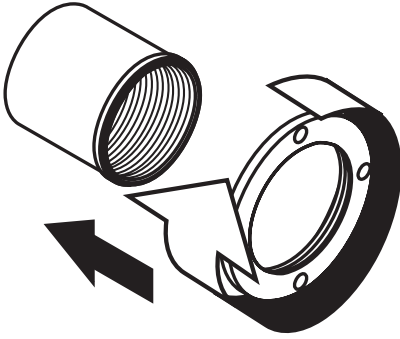

English

Connect the threaded rings to the selected sleeves.

Français

Raccordez les bagues filetées à les gaines sélectionnées.

Español

Conecte los aros roscados en los manguitos seleccionados.

Install the handle.

Installez la poignée.

Instale la manija.

12

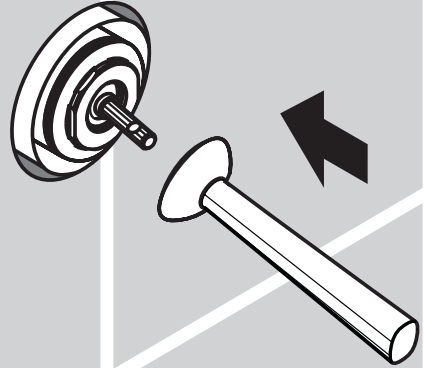

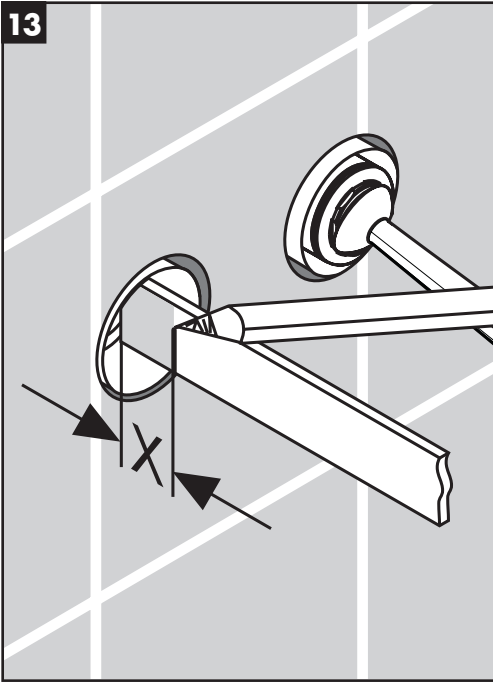
13**English**

Measure the distance from the surface of the spout port rough to the outside edge of the plaster shield ("X").

Add $1\frac{3}{4}$ " mm to X.

Cut the threaded nipple so that it is $X + 1\frac{3}{4}$ " long.

Français

Mesurez la distance entre la surface de la pièce du port de bec de remplissage et le rebord extérieur du protecteur (« X »).

Ajoutez $1\frac{3}{4}$ po à la mesure « X ».

Coupez le raccord fileté de façon à ce qu'il mesure « X » + $1\frac{3}{4}$ po de long.

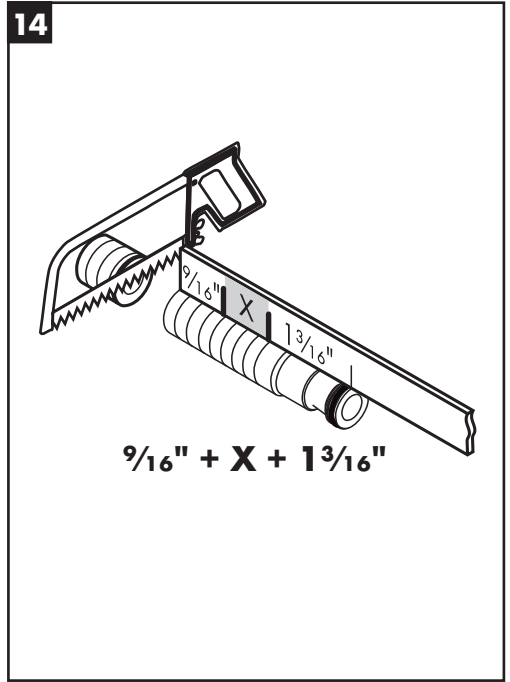
14**Español**

Mida la distancia desde la superficie de la parte interna del orificio del surtidor hasta el borde externo del protector de yeso ("X").

Agregue $1\frac{3}{4}$ " mm a X.

Corte el niple roscado para que tenga $X + 1\frac{3}{4}$ " de largo.

15

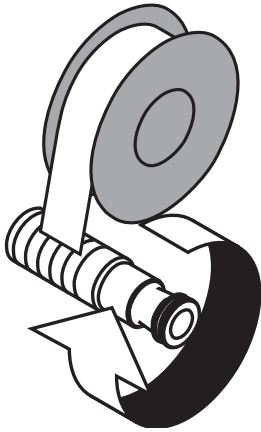

English

Wrap the threads on the nipple with plumbers tape.

Install the nipple.

Tighten the nipple using an 8 mm Allen wrench.

Français

Enveloppez les filets sur le raccord fileté avec du ruban de plomberie.

Installez le raccord fileté.

Serrez le raccord fileté à l'aide d'une clé hexagonale de 8 mm.

16

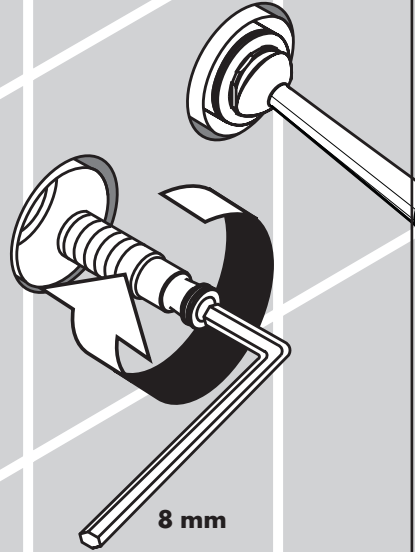

Español

Envuelva las roscas del niple con cinta de plomería.

Instale el niple.

Apriete el niple con una llave Allen de 8 mm.

17

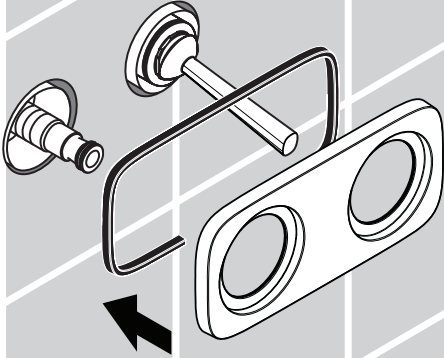

English

Install the baseplate.

Install the sleeve/threaded ring assemblies.

Français

Installez la plaque de base.

Installez les gaines et les bagues filetées.

18

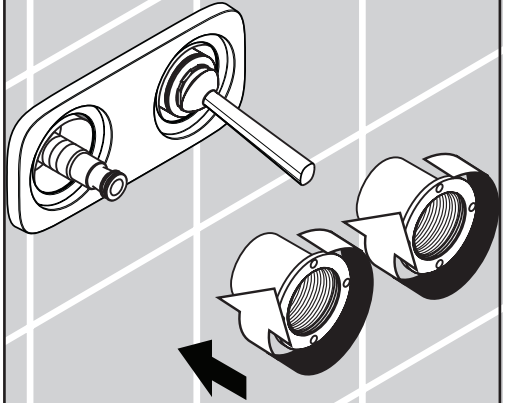

Español

Instale la placa de base.

Instale los manguito y los aros roscados.

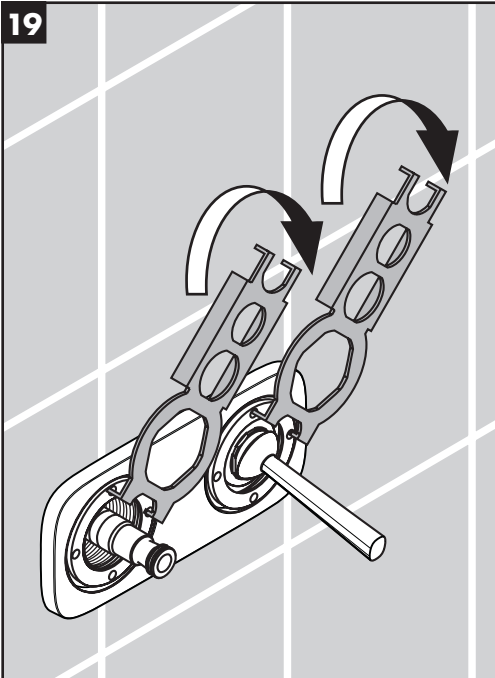

English

Tighten the threaded rings using the service key.

Lightly lubricate the o-ring on the spout cover.

Push the cover into place.

Français

Serrez-les en utilisant la clé de service.

Lubrifiez légèrement le joint torique du couvercle du bec de remplissage en utilisant de la graisse de plomberie blanche.

Installez le couvercle.

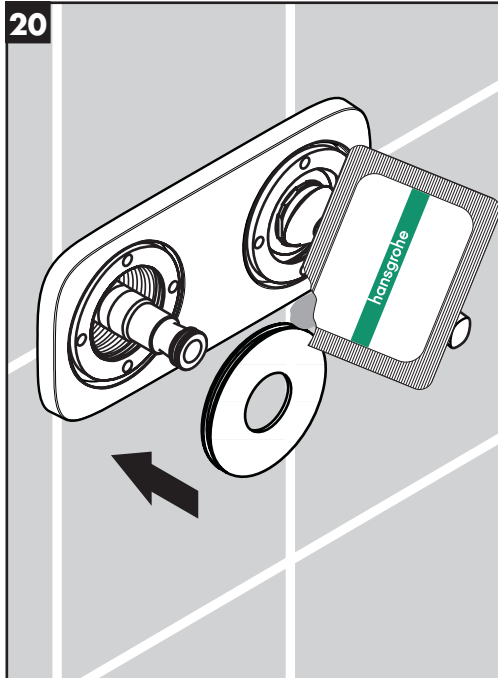

Español

Apriete los aros usando la llave de servicio.

Lubrique levemente la junta toroidal de la cobertura del surtidor utilizando grasa blanca para plomería.

Instale la cobertura.

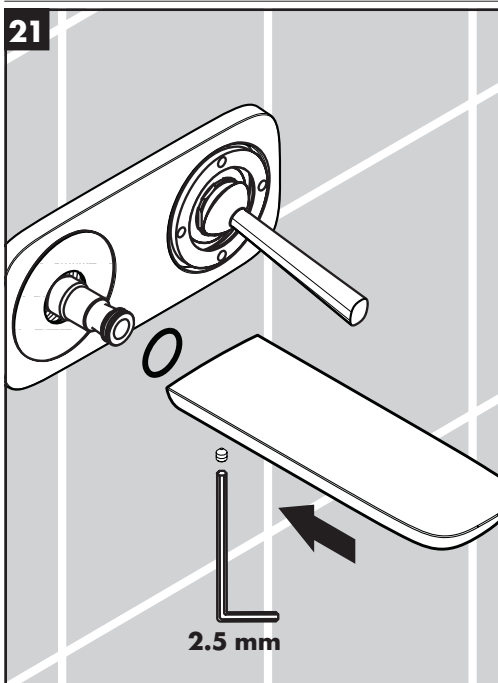

English

Push the spout over the nipple.
Tighten the spout screw using a 2.5 mm Allen wrench.

Lightly lubricate the o-ring on the handle cover.

Install the cover.

Install the flange.

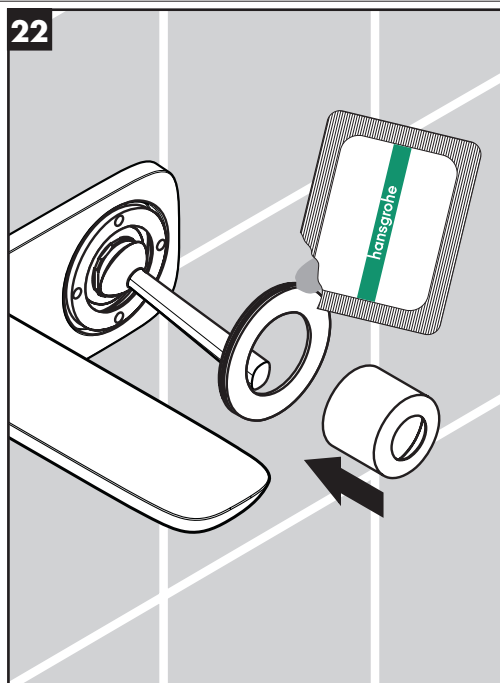

Español

Coloque el surtidor en su lugar sobre el niple.

Apriete el tornillo del surtidor con una llave Allen de 2.5 mm.

Lubrique la junta toroidal de la tapa con grasa blanca para plomería.

Instale la tapa.

Instale la brida.

Français

Poussez le bec de remplissage en place sur le raccord fileté.

Serrez la vis du bec à l'aide d'une clé hexagonale de 2.5 mm.

Lubrifiez légèrement le joint torique du couvercle de la poignée en utilisant de la graisse de plomberie blanche.

Installez le couvercle.

Installez la bride.

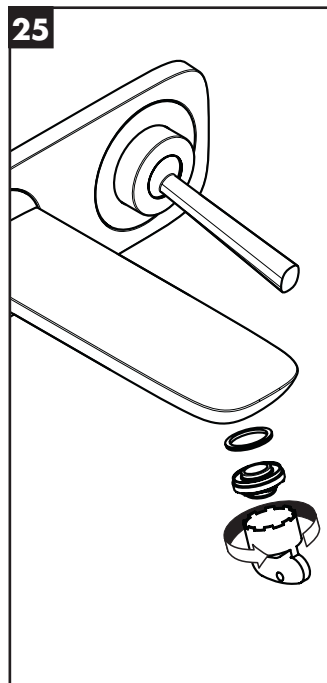
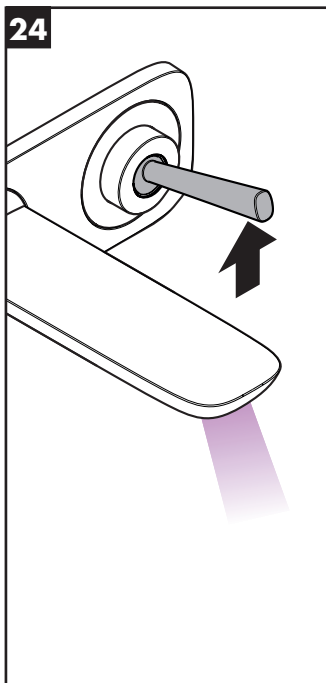
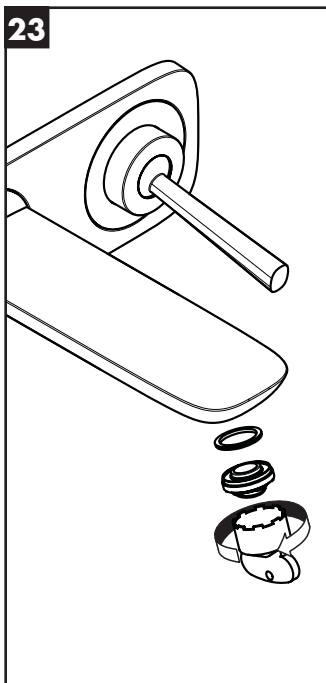

English

Remove the aerator.

Flush the faucet for at least two minutes.

Install the aerator.



Do not overtighten the aerator or damage will result.

Français

Retirez l'aérateur.

Rincez le robinet pendant au moins 2 minutes.

Installez l'aérateur.



Ne serrez pas trop l'aérateur, vous pourriez l'endommager.

Español

Retire el aireador.

Lave el grifo durante al menos 2 minutos.

Instale el aireador.



No apriete el aireador en exceso, puesto que podría dañarlo.

Replacement Parts / Pièces détachées / Repuestos

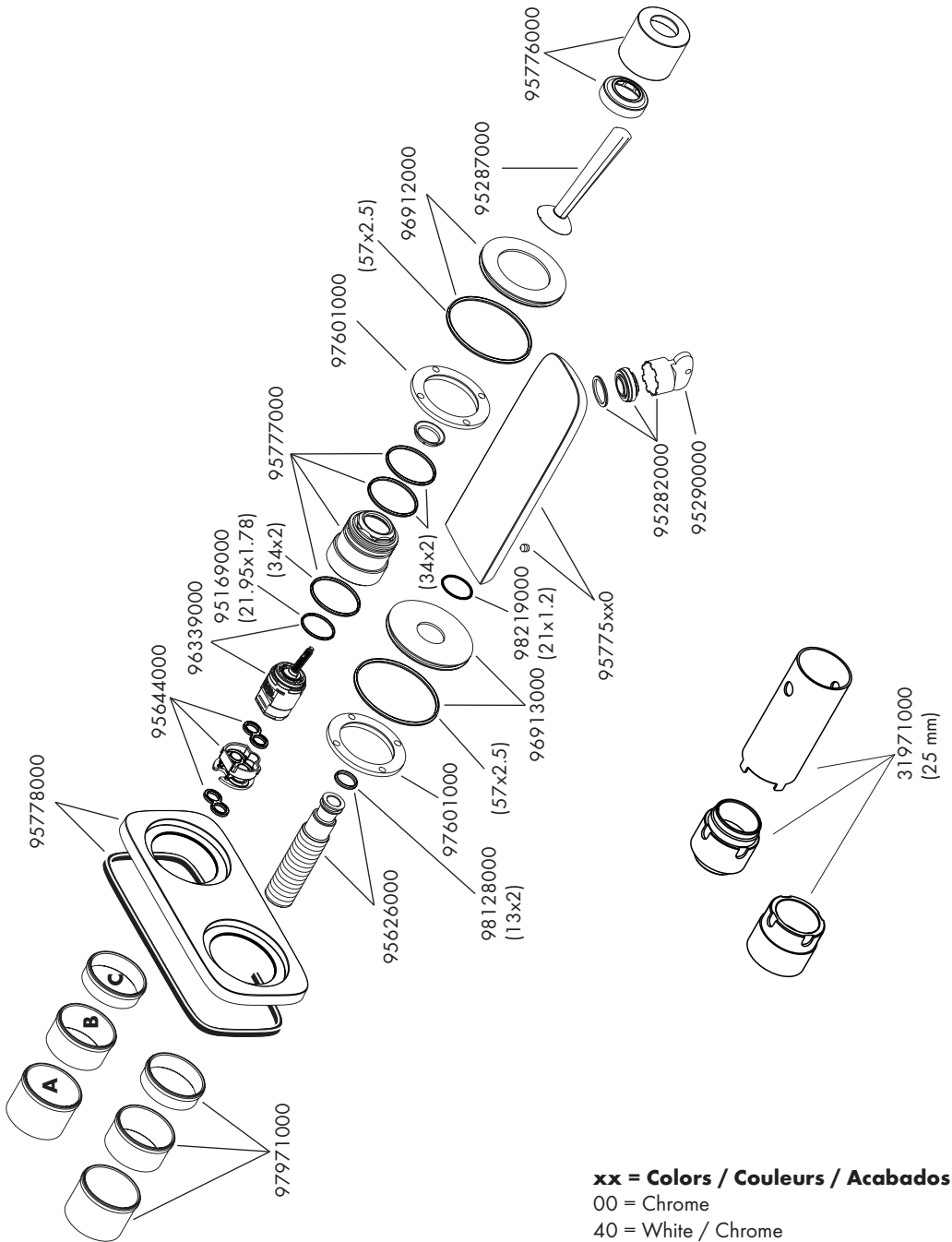

User Instructions / Instructions de service / Manejo

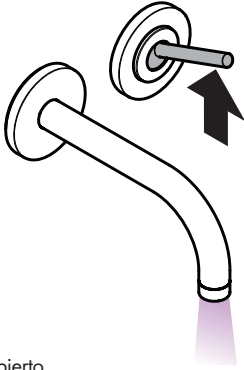

on / ouvert / abierto

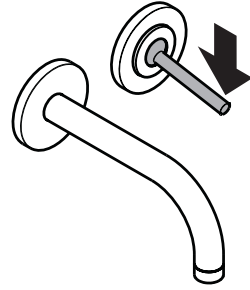

off / fermé / cerrar

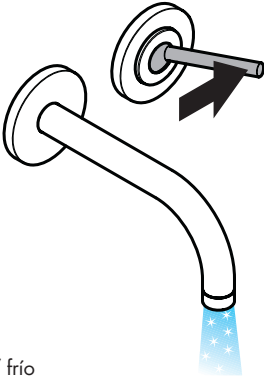

cold / froid / frío

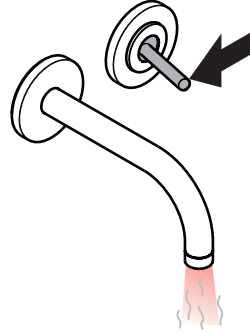

hot / chaud / caliente

Cleaning / Nettoyage / Limpieza

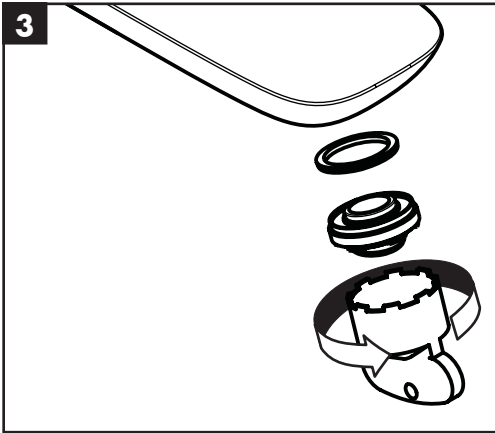
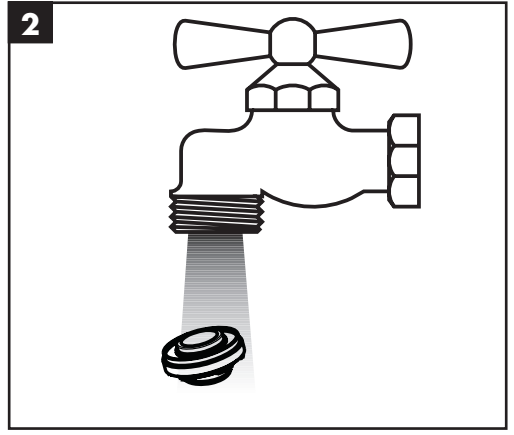
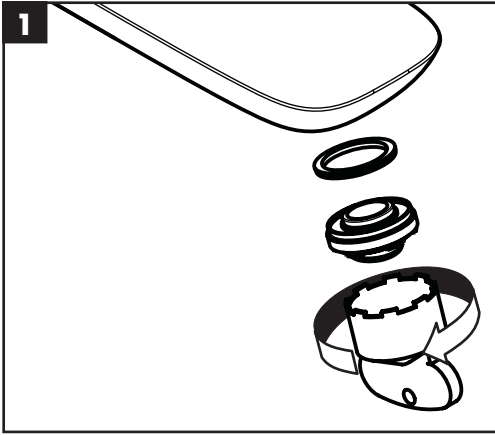

Cleaning Recommendation for Hansgrohe Products

Modern bathroom faucets, kitchen faucets and shower products are made from different materials to comply with the needs of the market with regard to design and functionality. To avoid damage to the product, it is necessary to take proper care of it.

For best results:

- Prevent the buildup of mineral scale and /or soap residue by cleaning your Hansgrohe product(s) when needed.
- Select a cleaning agent specifically intended for the type of product.
- **Do not** use these types of cleaners as they will cause damage to your Hansgrohe product:
 - ✘ Any cleaning agent containing hydrochloric acid, formic acid, lye, or acetic acid.
 - ✘ Abrasive cleaning powders, pads, or brushes.
 - ✘ Steam cleaners.
 - ✘ "No rinse" cleaning agents.
- **Always** follow the instructions provided by the manufacturer of the cleaning agent.
- **Do not** mix cleaning agents, unless directed by the manufacturer.
- **Do not** spray cleaners directly onto the product as drops could enter openings and gaps and cause damage. When using spray cleaners, spray the cleaner onto a soft cloth or sponge.
- **Always** rinse your Hansgrohe product thoroughly with clear water and polish dry with a soft cloth after cleaning.

Important

- Residue from soaps and shampoos can cause damage. Rinse the product with clean water after each use.
- Residue from basin/tub/tile cleaner can cause damage to faucets and fittings. Immediately rinse any overspray from the Hansgrohe product.
- **Damage to the product caused by improper care or the use of improper cleaning agents is not covered by the warranty.**
- **If a component of the product is damaged, replace it, as there is risk of injury.**

Conseil de nettoyage pour les produits Hansgrohe

Les robinets pour les salles de bains et les cuisines modernes ainsi que les produits récents pour les douches se composent de matériaux différents afin de satisfaire aux besoins du marché en termes de conception et de fonctionnalité. Afin d'éviter d'endommager le produit, il est nécessaire d'en prendre soin.

Pour de meilleurs résultats :

- Empêchez l'accumulation de tarte et/ou de résidu de savon en nettoyant votre produit Hansgrohe lorsque c'est nécessaire.
- Sélectionnez un produit de nettoyage spécifiquement prévu pour ce type de produit.
- **N'utilisez pas** ces types de nettoyeurs car ils peuvent endommager votre produit Hansgrohe :
 - ✘ Tout produit de nettoyage contenant de l'acide chlorhydrique, de l'acide formique, de la potasse ou de l'acide acétique.
 - ✘ Les poudres de nettoyage, les tampons ou les brosses abrasives.
 - ✘ Les nettoyeurs à vapeur.
 - ✘ Les produits de nettoyage « sans rinçage ».

-
- **Ne mélangez pas** les produits de nettoyage, à moins que cela soit indiqué par le fabricant.
 - **Ne pulvérisez pas** les nettoyeurs directement sur le produit car des gouttes pourraient entrer dans les ouvertures et les fentes et causer des dommages. Lorsque vous utilisez des nettoyeurs par pulvérisation, pulvérisez le nettoyeur sur un chiffon ou une éponge douce.

Important

- Le résidu provenant des savons et des shampoings peut causer des dommages. Rincez le produit avec de l'eau propre après chaque utilisation.
- Le résidu provenant des nettoyeurs pour cuvette/baignoire/carrelage peut endommager les robinets et les raccords de tuyauterie. Rincez immédiatement toute surpulvérisation sur le produit Hansgrohe.
- De meme, il est interdit de stocker des détergents ou des produits chimiques sous les produits, par ex. dans un meuble sous lavabo, car les vapeurs qui s'en dégagent risquent d'abîmer les produits.
- **Les dommages au produit causés par un mauvais entretien ou par l'utilisation de produits de nettoyage inadéquats ne sont pas couverts par la garantie.**
- **Si un composant du produit est endommagé, remplacez-le, car il existe un risque de blessure.**

Recomendación de limpieza para los productos de Hansgrohe

Hoy en día, las griferías de baño y de cocina así como duchas modernas se componen de materiales muy distintos para satisfacer las exigencias del mercado respecto al diseño y la funcionalidad. Para evitar daños y reclamaciones hay que tener en cuenta ciertos aspectos tanto en el uso como en su limpieza.

Para obtener mejores resultados:

- Evite la acumulación de restos de jabón o sarro limpiando el producto Hansgrohe cuando sea necesario.
- Seleccione un agente de limpieza diseñado específicamente para el tipo de producto.
- **No** use estos tipos de limpiadores, ya que causarán daño a su producto Hansgrohe:
 - ✘ Agentes limpiadores que contengan ácido clorhídrico, fórmico, acético o lejía.
 - ✘ Polvos, paños o cepillos de limpieza abrasivos.
 - ✘ Limpiadores a vapor
 - ✘ Agentes de limpieza "sin enjuague".
- **Siempre** siga las instrucciones provistas por el fabricante del agente de limpieza.
- **No** mezcle los agentes de limpieza, a menos que esté indicado por el fabricante.
- **No** rocíe limpiadores directamente sobre el producto, ya que podrían caer gotas sobre las aberturas y espacios y causar daños. Cuando use limpiadores en spray, rocíe el limpiador sobre un paño suave o esponja.
- **Siempre** enjuague su producto Hansgrohe con agua limpia y séquelo y lustrelo con un paño suave después de la limpieza.

Importante

- Los residuos de jabón y champú pueden causar daños. Enjuague el producto con agua limpia después de cada uso.
- Los residuos de limpiadores para lavatorios, bañeras o azulejos pueden causar daño a los grifos y accesorios. Enjuague inmediatamente cualquier derrame que haya sobre el producto de Hansgrohe.
- Tampoco pueden generarse depósitos de productos de limpieza o químicos debajo de los productos, p. ej. En un armario de lavabo. De lo contrario, los vapores generados pueden dañar los productos.
- **Los daños que resulten de un cuidado inadecuado o uso de agentes de limpieza inadecuados no están cubiertos por la garantía**
- Si se daña un componente del producto, reemplácelo, ya que existe riesgo de lesión.

Limited Consumer Warranty

This product has been manufactured and tested to the highest quality standards by Hansgrohe, Inc. ("Hansgrohe"). This warranty is limited to Hansgrohe products that are purchased by a consumer in the United States or Canada after March 1, 1996, and installed in either in the United States or in Canada.

WHO IS COVERED BY THE WARRANTY

This warranty extends to the original purchaser only. This warranty is non-transferable.

WHAT IS COVERED BY THE WARRANTY

The warranty covers only your Hansgrohe manufactured product. Hansgrohe warrants this product against defects in material or workmanship as follows:

Hansgrohe will replace at no charge for parts only or, at its option, replace any product or part of the product that proves defective because of improper workmanship and/or material, under normal installation, use, service and maintenance. If Hansgrohe is unable to provide a replacement and repair is not practical or cannot be made in timely fashion, Hansgrohe may elect to refund the purchase price in exchange for the return of the product.

LENGTH OF WARRANTY

Replacement or repaired parts of products will be covered for the term of this warranty, as stated in the following two sentences. If you are a consumer who purchased the product for use primarily for personal, family or household purposes, this warranty extends for as long as you own the product and the home in which the product is originally installed. If you purchased the product for use primarily for any other purpose, including, without limitation, a commercial purpose, this warranty extends only (i) for 1 year, with respect to Hansgrohe & Commercial products, and (ii) for 5 years, with respect to Axor products.

THIS WARRANTY DOES NOT COVER, AND HANSGROHE WILL NOT PAY FOR:

- A. Conditions, malfunctions or damage not resulting from defects in material or workmanship.
- B. Conditions, malfunctions or damage resulting from (1) normal wear and tear, improper installation, improper maintenance, misuse, abuse, negligence, accident or alteration; (2) the use of abrasive or caustic cleaning agents or "no-rinse" cleaning products, or the use of the product in any manner contrary to the product instructions; or (3) conditions in the home such as excessive water pressure or corrosion.
- C. Labor and other expenses for disconnection, deinstallation, or return of the product for warranty service (including but not limited to proper packaging and shipping costs), or for installation or reinstallation of the product.
- D. Accessories, connected materials and products, or related products not manufactured by Hansgrohe.
- E. Any Hansgrohe or Axor product sold for display purposes.
- F. Rubbed Bronze finish is subject to a 3-year limited warranty. Chrome and all PVD finishes are covered by the limited lifetime warranty.
- G. Hansgrohe Water Filtration System is subject to a 1-year limited warranty. Warranty does not include replacement filters.

TO OBTAIN WARRANTY PARTS OR INFORMATION

Contact your Hansgrohe retailer, or contact Technical Service at:

Hansgrohe, Inc.
1492 Bluegrass Lakes Parkway
Alpharetta, GA 30004
Toll-free 800-334-0455

In requesting warranty service, you will need to provide:

1. The sales receipt or other evidence of the date and place of purchase.
2. A description of the problem.
3. Delivery of the product or the defective part, postage prepaid and carefully packed and insured, to:

Hansgrohe, Inc.
1492 Bluegrass Lakes Parkway
Alpharetta, GA 30004
Toll-free 800-334-0455

When warranty service is completed, any repaired or replacement product or part will be returned to you postage prepaid.

EXCLUSIONS AND LIMITATIONS

REPAIR OR REPLACEMENT (OR, IN LIMITED CIRCUMSTANCES, REFUND OF THE PURCHASE PRICE) AS PROVIDED UNDER THIS WARRANTY IS THE EXCLUSIVE REMEDY OF THE PURCHASER. HANSGROHE NEITHER ASSUMES NOR AUTHORIZES ANY PERSON TO CREATE FOR IT ANY OTHER OBLIGATION OR LIABILITY IN CONNECTION WITH THIS PRODUCT. HANSGROHE SHALL NOT BE LIABLE TO PURCHASER OR ANY OTHER PERSON FOR ANY INCIDENTAL, SPECIAL OR CONSEQUENTIAL DAMAGES, ARISING OUT OF BREACH OF THIS WARRANTY OR ANY IMPLIED WARRANTY (INCLUDING BUT NOT LIMITED TO ANY IMPLIED WARRANTY OF MERCHANTABILITY).

Some States do not allow the exclusion or limitation of incidental or consequential damages, so the above limitation or exclusion may not apply to you. This warranty gives you specific legal rights, and you may also have other rights that vary from state to state.

TO THE EXTENT PERMITTED BY LAW, ANY IMPLIED WARRANTIES OF MERCHANTABILITY AND FITNESS FOR A PARTICULAR PURPOSE, ARE LIMITED TO THE DURATION OF THE EXPRESS WARRANTY.

Some states do not allow limitations on how long an implied warranty may last, so the above limitations may not apply to you. You may be required by law to give us a reasonable opportunity to correct or cure any failure to comply before you can bring any action in court against us under the Magnuson-Moss Warranty Act.

PRODUCT INSTRUCTIONS AND QUESTIONS

Upon purchase or prior to installation, please carefully inspect your Hansgrohe product for any damage or visible defect. Prior to installing, always carefully study the enclosed instructions on the proper installation and the care and maintenance of this product. If you have questions at any time about the use, installation or performance of your Hansgrohe product, or this warranty, please write us or call us toll-free at 800-334-0455.

hansgrohe

Hansgrohe, Inc. • 1490 Bluegrass Lakes Parkway • Alpharetta, GA 30004
Tel. 800-334-0455 • Fax 770-889-1783

www.hansgrohe-usa.com