

- EN** Installation / User Instructions / Warranty
- FR** Instructions de montage / Mode d'emploi / Garantie
- ES** Instrucciones de montaje / Manejo / Garantía

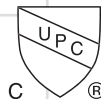
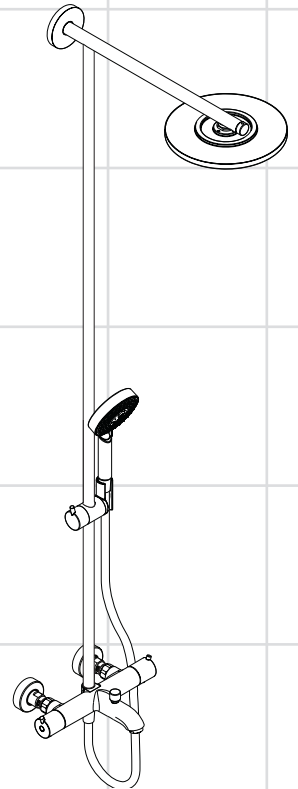

Raindance Showerpipe
27146xx1

Technical Information

Recommended water pressure	15 - 75 PSI
Max. water pressure	145 PSI
Recommended hot water temp.	120° - 140° F*
Max. hot water temp	176° F*
Flow rate - showerhead	2.5 GPM max.
Flow rate - handshower	2.5 GPM max.
Flow rate - tub filler	5.3 GPM@ 44 PSI

*Please know and follow all applicable local plumbing codes when setting the temperature on the water heater.

Installation Considerations

- This showerpipe is for use with shower heads rated at 2.5 GPM (9.4 l/min) or higher.
- For best results, Hansgrohe recommends that this unit be installed by a licensed, professional plumber.
- Please read over these instructions thoroughly before beginning installation. Make sure that you have all tools and supplies needed to complete the installation.
- The installation dimensions shown in this installation instruction are ideal for people of approximately 6' in height. The dimensions can be changed if required. In this case, the minimum ceiling height of 84¹/₈" from the standing surface, and all other measurements, must be changed.
- The installer must ensure that the entire area of the wall to which the mounting plate is to be mounted, is flat (no protruding grout joints or tiles). He should also make sure that the wall is strong enough to support the showerpipe.
- The enclosed screws and anchors are suitable for a solid surface wall. If installing in a fiberglass or acrylic shower unit, install header boards at the mounting points.
- This showerpipe requires showerpipe rough 16181181(not included).
- To prevent scald injury, the maximum output temperature of the shower valve must be no higher than 120°F. In Massachusetts, the maximum output temperature can be no higher than 112°F.
- Keep this booklet and the receipt (or other proof of date and place of purchase) for this product in a safe place. The receipt is required should it be necessary to request warranty parts.

Données techniques

Pression d'eau recommandée	15 - 75 PSI
Pression d'eau maximum	145 PSI
Température recommandée d'eau chaude	120° - 140° F*
Température maximum d'eau chaude	176° F*
Capacité nominale - pomme de douche	2.5 GPM
Capacité nominale - douchette	2.5 GPM
Capacité nominale - bec	5.3 GPM @ 44 PSI

* Vous devez connaître et respecter tous les codes de plomberie locaux applicables pour le réglage de la température du chauffe-eau.

À prendre en considération pour l'installation

- Ce produit devrait être seulement utilisé avec les pommes de douche évaluées à 2,5 GPM (9.4 l/min) ou plus.
- Pour de meilleurs résultats, Hansgrohe recommande que ce produit soit installé par un plombier professionnel licencié.
- Veuillez lire attentivement ces instructions avant de procéder à l'installation. Assurez-vous de disposer de tous les outils et du matériel nécessaires pour l'installation.
- Les dimensions d'installation données dans la notice de montage sont idéales pour une personne de 1800 mm de hauteur et doivent être ajustées selon le besoin. A ce sujet il faut tenir compte, pour un changement de hauteur, que la cote minimum donnée de 2135 mm à partir de la base du receveur change et la modification du montage sera à prendre en considération.
- Lors du montage du produit par un ouvrier qualifié, il faut faire attention à ce que la surface de fixation soit plane sur toute son étendue (aucun dépassement de joint ni de carrelage), que la construction de la paroi soit adaptée à l'installation du produit et surtout ne présente aucun point faible. Les vis et les chevilles fournies sont uniquement appropriées au béton. Pour les autres constructions, il faudra tenir compte des préconisations du fabricant de cheville.
- Ce dispositif requiert une pièce intérieure 16181181.
- Pour empêcher des blessures par ébouillement, la température de sortie maximale du robinet de douche ne doit pas excéder 120°F. Au Massachusetts, la température de sortie maximale du robinet de douche ne doit pas excéder 112°F.
- Conservez ce livret et le reçu (ou une autre preuve sur laquelle figurent la date et l'endroit de l'achat) pour ce produit dans un endroit sûr. Le reçu est requis si vous commandez des pièces sous garantie.

Datos técnicos

Presión recomendada en servicio	15 - 75 PSI
Presión en servicio max.	145 PSI
Temperatura recomendada del agua caliente	120° - 140° F*
Temperatura del agua caliente max.	176° F*
Caudal máximo - ducha cabezal	2.5 GPM
Caudal máximo - teleducha	2.5 GPM
Caudal máximo - caño	5.3 GPM @ 44 PSI

*Debe conocer y cumplir todos los códigos locales aplicables para ajustar la temperatura del calentador de agua.

Consideraciones para la instalación

- Este producto debe ser utilizado sólo con alcachofas de la ducha valoradas en 2,5 GPM (9.4 L/min) o más.
- Para obtener mejores resultados, la instalación debe estar a cargo de un plomero profesional matriculado.
- Antes de comenzar la instalación, lea estas instrucciones detenidamente. Asegúrese de tener las herramientas y los insumos necesarios para completar la instalación.
- Las medidas indicadas en las instrucciones de montaje resultan ideales para personas de 1800 mm de altura, por lo que deberán ajustarse siempre que sea necesario. En este sentido, es importante tener en cuenta que, en caso de modificación de la altura de montaje, será necesario respetar el requisito de 2135 mm de altura mínima desde la base de la ducha y observar las medidas de conexión.
- En el momento del montaje del producto por parte de personal especializado y cualificado se deberá prestar una atención especial a que la superficie de fijación en toda el área de la fijación sea plana (sin juntas que sobresalen ni azulejos desplazados), que la estructura de la pared sea adecuada para un montaje del producto y que, ante todo, no presente puntos débiles. Los tornillos y tacos adjuntos son sólo apropiados para hormigón. En el caso de otras estructuras murales se deberán considerar las indicaciones del fabricante de tacos.
- La unidad requiere una pieza interior de válvula 16181181.
- Para evitar escaldaduras, la máxima temperatura de salida de la válvula de la ducha no debe exceder los 120°F. En Massachusetts, la máxima temperatura de salida de la válvula de la ducha no debe exceder los 112°F.
- Mantenga este folleto y el recibo (u otro comprobante del lugar y fecha de compra) de este producto en lugar seguro. El recibo se requiere en caso de ser necesario solicitar piezas bajo garantía.

Tools Required / Outils Utiles / Herramientas Útiles

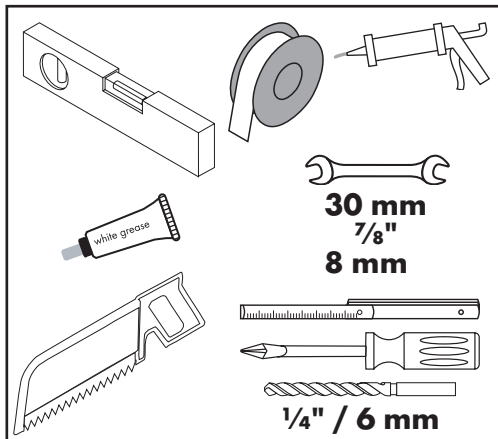

This unit meets or exceeds the following:

- ASME A112.18.1
- CSA B125.1
- Listed by IAPMO for use in the US and Canada

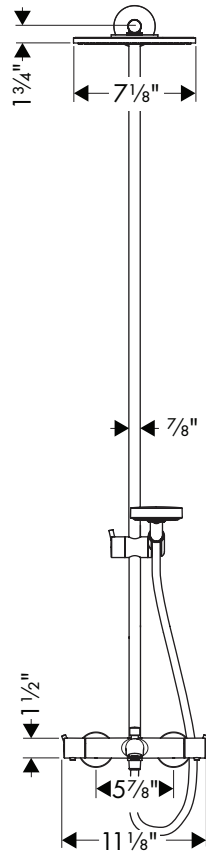
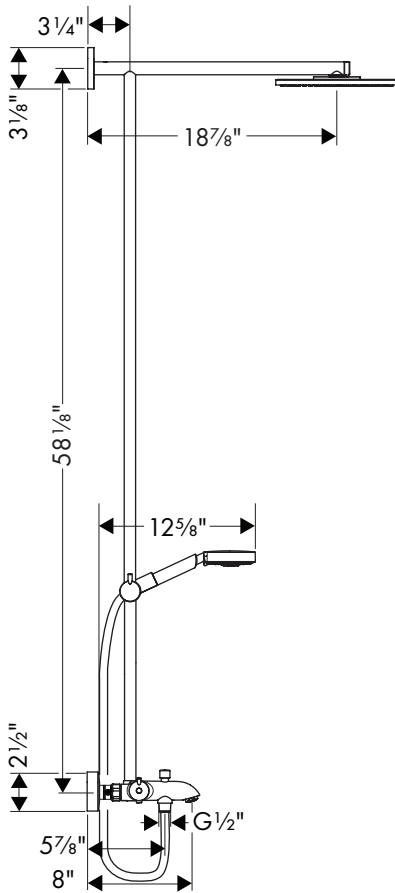

Installation Suggestion

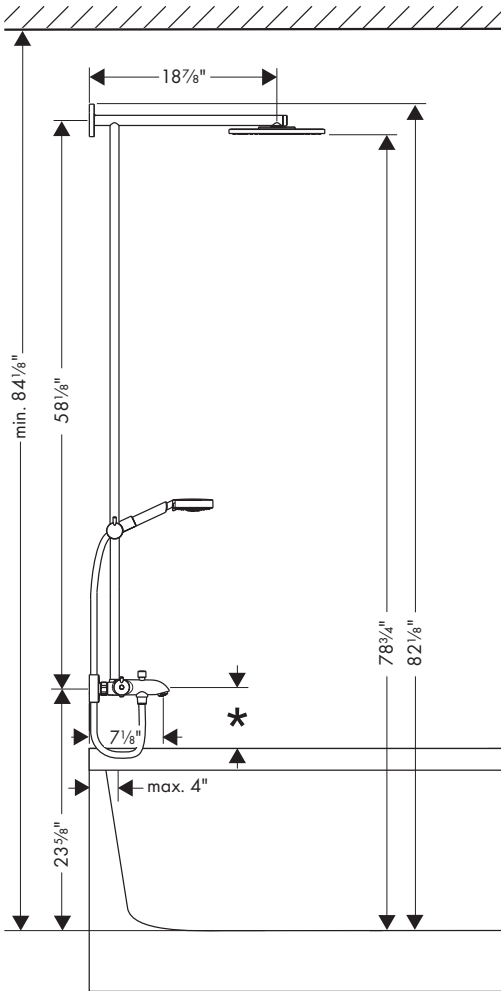

* Please know and follow all applicable local plumbing codes regarding the air gap between the tub spout and the flood level of the tub.

* Vous devez connaître et respecter tous les codes de plomberie locaux applicables en installant ce robinet.

* Debe conocer y cumplir todos los códigos locales aplicables al instalar este chorro.

Using the Stops

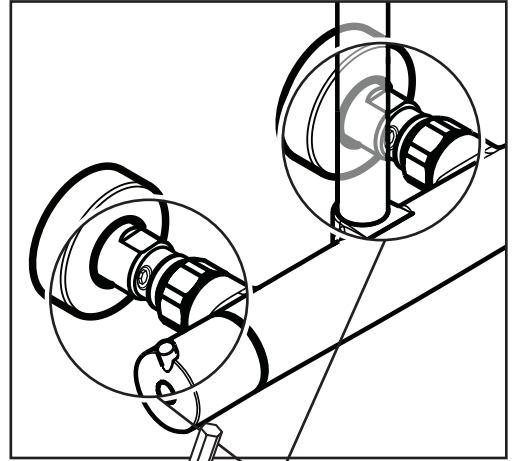

4 mm

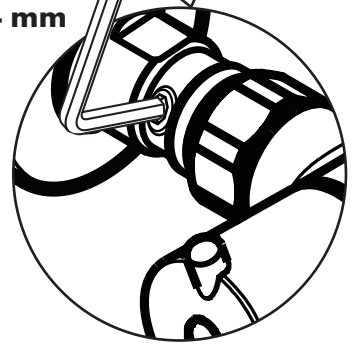

closed
fermé
cerrado

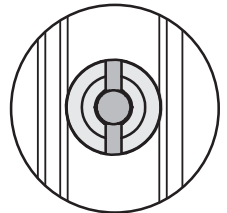

open
ouvert
abierto

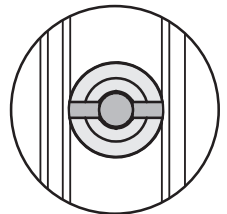

Installation / Installation / Instalación

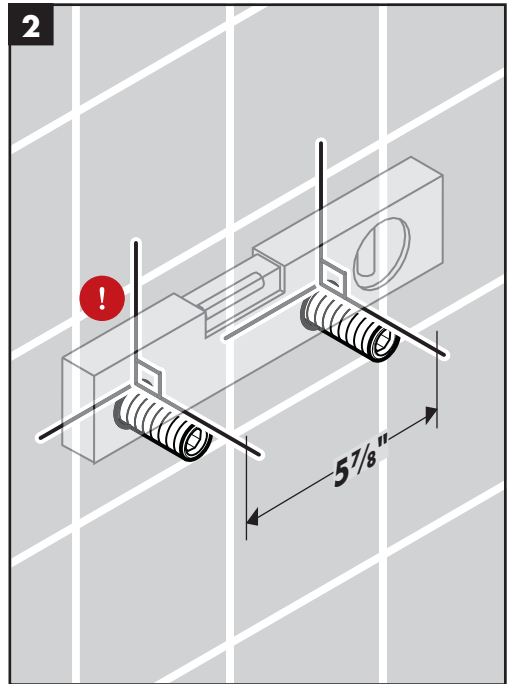
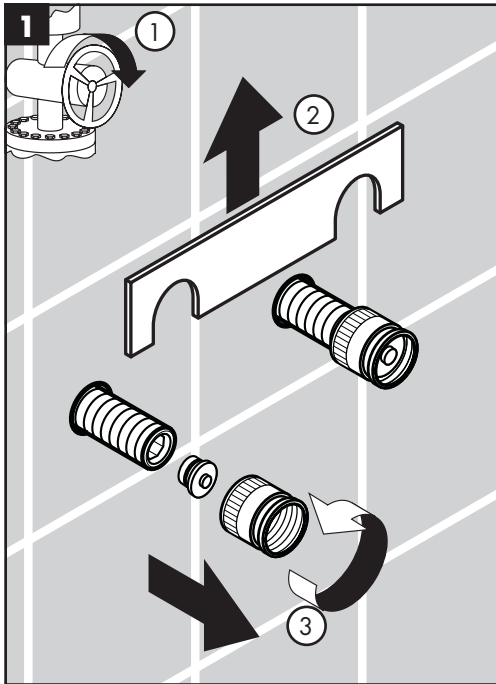

English

The showerpipe must be installed with showerpipe rough set 16181181 (not included).

! To insure correct operation of the thermostatic mixing valve, the hot supply must be on the left and the cold supply must be on the right.

Turn the water off at the main.

Remove the spacing jig, nuts, and plugs.

Confirm that the nipples are level in all planes and are parallel to each other.

Français

Le showerpipe doit être installé avec l'ensemble de pièce intérieure pour tuyau de douche 16181181 (non inclus).

! Pour vous assurer que le mélangeur thermostatique fonctionne correctement, installez la conduite d'eau chaude à gauche et la conduite d'eau froide à droite.

Fermez l'eau à la valve principale.

Retirez le gabarit d'espacement, les écrous et les bouchons.

Assurez-vous que les raccords filetés sont au niveau sur tous les plans et installés de manière parallèle.

Español

El showerpipe debe ser instalado con un juego de piezas interiores del tubo de ducha 16181181 (no incluido).

! Para que la válvula mezcladora termostática funcione correctamente, el suministro de agua caliente debe estar a la izquierda y el de agua fría a la derecha.

Cierre el paso del agua en la entrada del suministro.

Retire la plantilla espaciadora, las tuercas y los tapones.

Confirme que los nipples estén nivelados en todos los planos y paralelos entre sí.

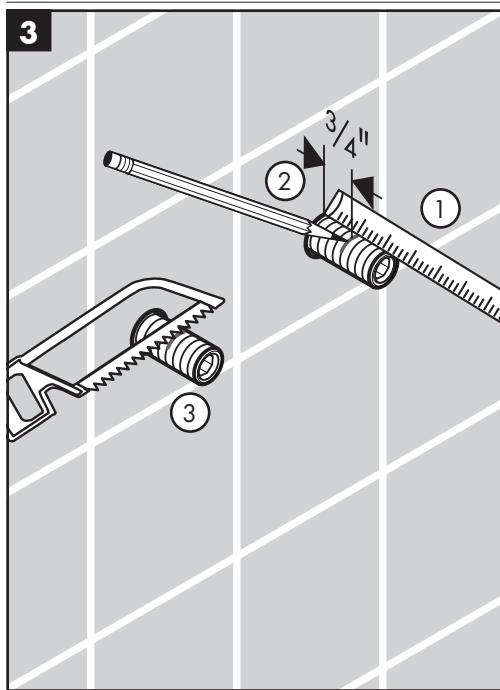

English

Mark a point on each nipple $\frac{3}{4}$ " from the surface of the finished wall

Carefully cut the nipple at this point.

! Seal the wall around the nipples with waterproof sealant.

Failure to seal the wall may result in water damage.

Install the escutcheon mounting plates.

Wrap the nipples with plumbers' tape.

Français

Faites une marque sur chaque raccord fileté à $\frac{3}{4}$ po de la surface du mur fini.

Coupez soigneusement le raccord fileté sur cette marque.

! Scellez le mur autour des raccords filetés à l'aide d'un agent d'étanchéité.

Si le mur n'est pas scellé, l'eau pourrait éventuellement causer des dommages.

Installez les plaques de montage pour les écussons.

Enveloppez les raccords filetés avec du ruban de plombier.

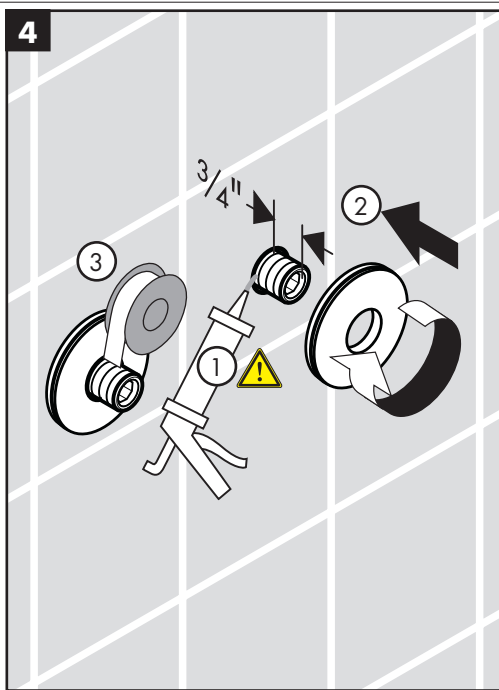

Español

Marque un punto en cada niple de $\frac{3}{4}$ " desde la superficie de la pared terminada.

Corte cuidadosamente el niple en este punto.

! Selle la pared alrededor de los niples con un sellador impermeable.

Si la pared no se sella, pueden producirse daños por acción del agua.

Instale las piezas de montaje para los escudos.

Envuelva los niples con cinta de plomero.

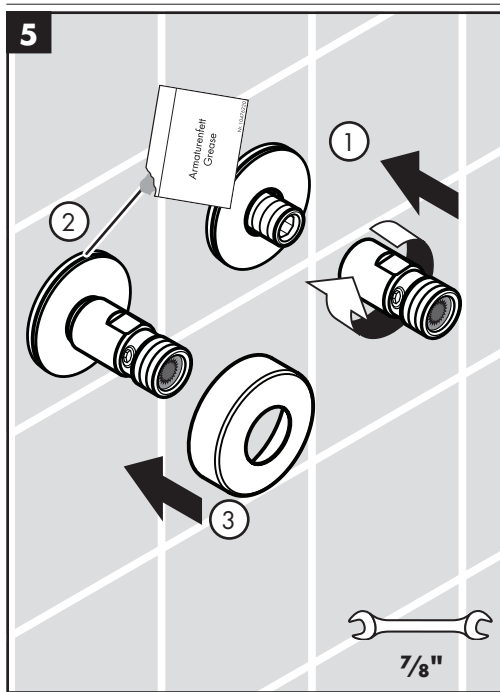

English

Install the stops.

Lightly lubricate the o-rings on the mounting plates using white plumbers' grease.

Install the escutcheons.

Install the mixer.

Tighten the nuts

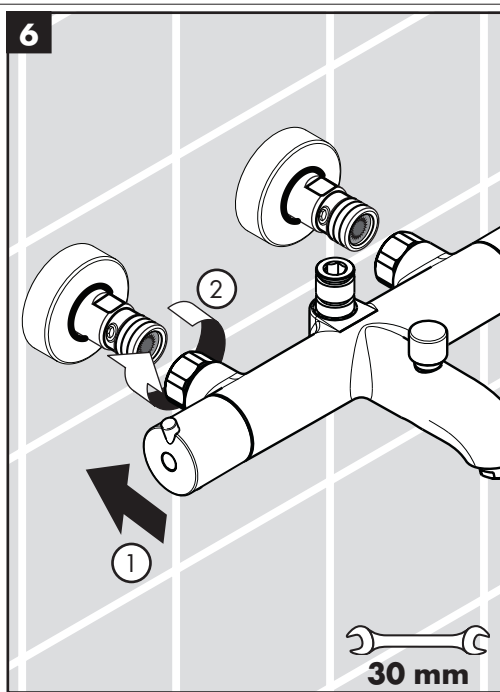

Español

Instale las válvulas.

Lubrique las juntas.

Instale los escudos.

Instale la mezcladora
termostática.

Apriete las tuercas.

Français

Installez les boîtiers de service.

Lubrifiez les joints toriques.

Installez les écussons.

Installez le mélangeur
thermostatique.

Serrez les écrous.

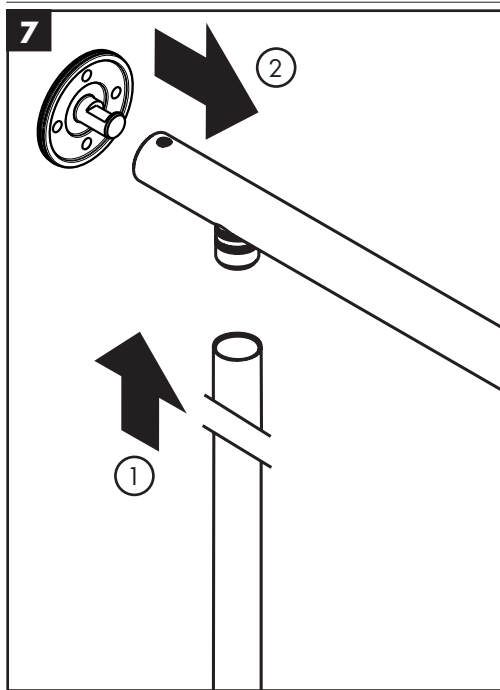

English

Press the shower arm onto the riser.

Press the mounting piece into the shower arm.

Place the riser on the valve.

Make sure that it is level.

Mark the positions of the screw holes.

Remove the riser and shower arm.

Français

Poussez le bras de douche sur la colonne montante.

Poussez la plaque de montage sur le bras de douche.

Poussez la colonne montante fermement sur la sortie de valve.

Assurez-vous que la colonne montante soit de niveau.

Marquez les positions des trous de vissage.

Retirez la colonne montante e la bras de douche.

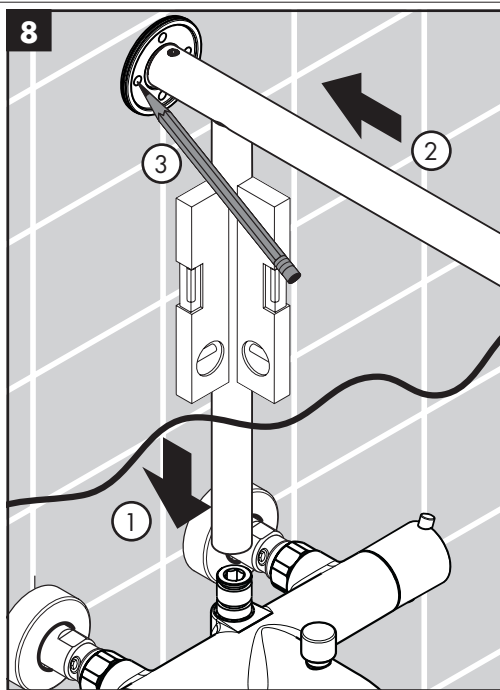

Español

Presione el brazo de ducha en la tubería de subida.

Presione la placa de montaje en el brazo de ducha.

Presione la tubería de subida firmemente sobre la salida de la válvula.

Asegúrese de que la tubería de subida quede nivelada.

Marque las posiciones de los orificios para tornillos.

Retire el brazo de ducha y la tubería de subida.

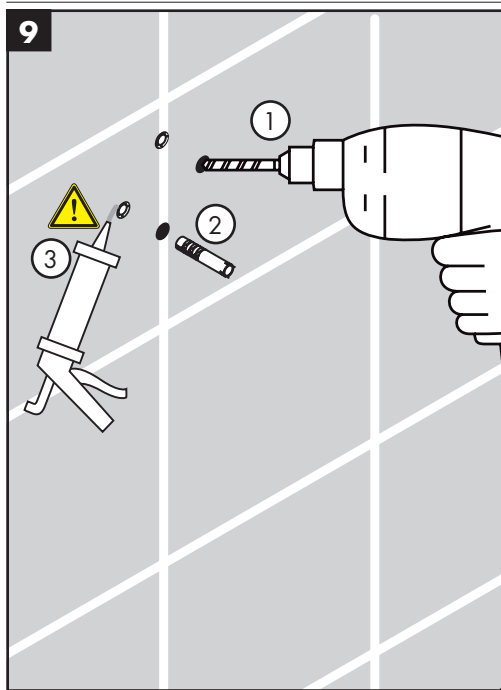

English

Drill the holes.

Install the anchors.

! Seal the wall around the anchors with waterproof sealant.

Install the shower arm mounting plate using the included screws and washers.

OR

If the tile does not go all the way up the wall, install the mounting plate with the tile matching disk.

! Do not tighten the screws completely.

Français

Percez les trous.

Installez les chevilles.

! Scellez le mur autour des chevilles à l'aide d'un agent d'étanchéité.

Installez la plaque de montage du bras de douche en utilisant les vis et rondelles fournies.

OU

Si les carreaux ne couvrent pas la surface jusqu'au plafond, installez la plaque de montage avec le disque adaptateur.

! Ne serrez pas complètement les vis.

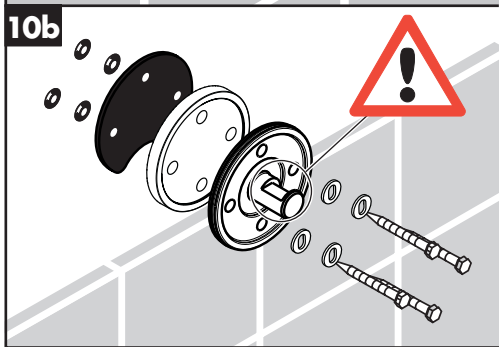
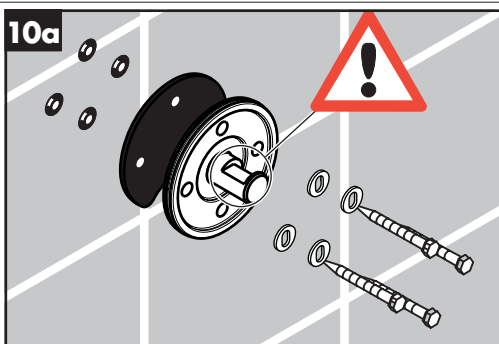

Español

Perfore los orificios.

Instale los pernos de anclaje.

! Selle la pared alrededor de los pernos de anclaje con un sellador impermeable.

Instale la placa de montaje del brazo de ducha utilizando las arandelas y los tornillos incluidos.

O

Si el azulejo no va hasta arriba de la pared, instale la placa de montaje con el disco que coincida con el azulejo.

! No ajuste los tornillos completamente.

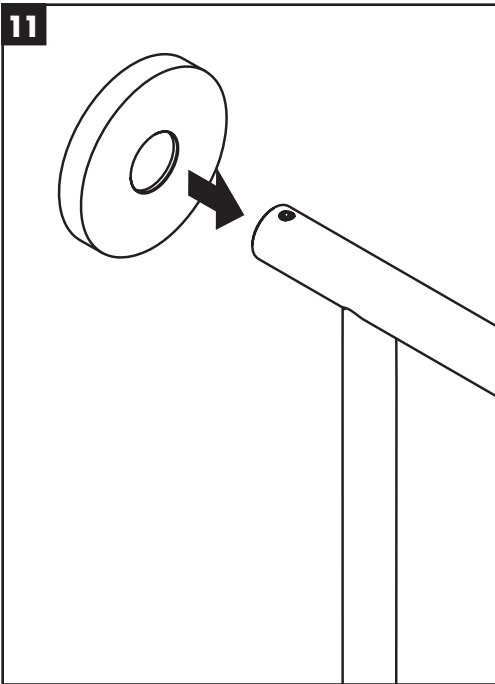

English

Press the shower arm onto the riser.

Place the escutcheon on the shower arm.

Push the riser firmly over the valve outlet.

! **Make sure that the riser is level.**

Push the shower arm assembly over the mounting plate.

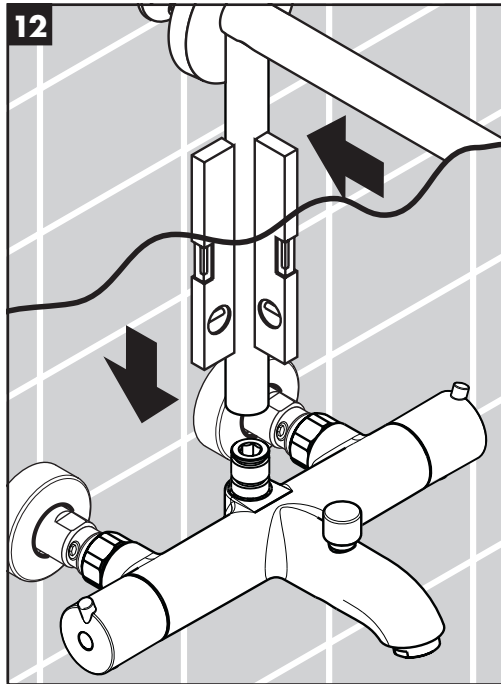

Français

Poussez le bras de douche sur la colonne montante.

Placez l'écusson sur le bras de douche.

Poussez la colonne montante fermement sur la sortie de valve.

! **Assurez-vous que la colonne montante soit de niveau.**

Puis l'assemblage du bras de douche sur la plaque de montage.

Español

Presione el brazo de ducha en la tubería de subida.

Coloque el escudo en el brazo de ducha.

Presione la tubería de subida firmemente sobre la salida de la válvula.

! **Asegúrese de que la tubería de subida quede nivelada.**

Presione el brazo de ducha sobre la placa de montaje.

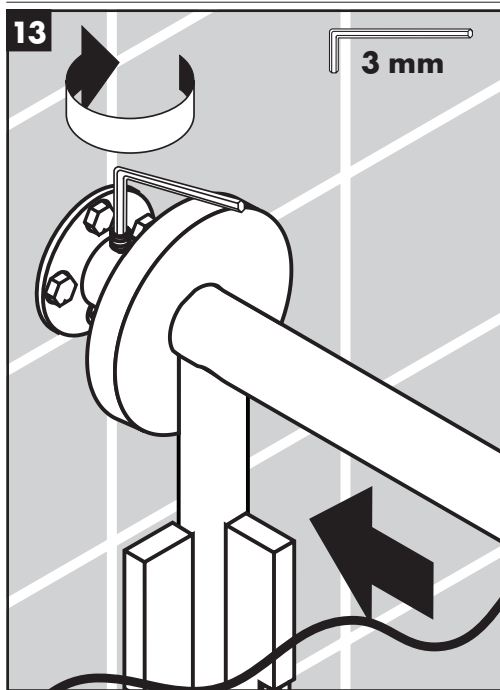

English

Tighten the screw using a 3 mm Allen wrench.

Français

Serrez la vis à l'aide d'une clé hexagonale de 3 mm.

Español

Apriete el tornillo con una llave Allen de 3 mm.

Remove the screw from the showerhead.

Enlevez la vis de la pomme de douche.

Quite el tornillo de la ducha cabedal.

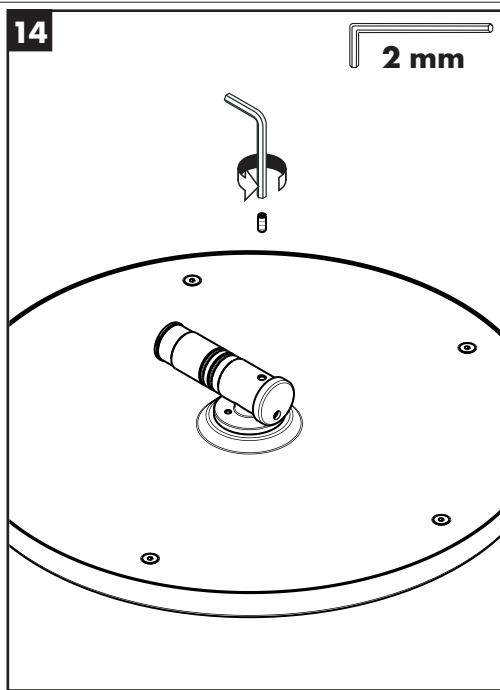

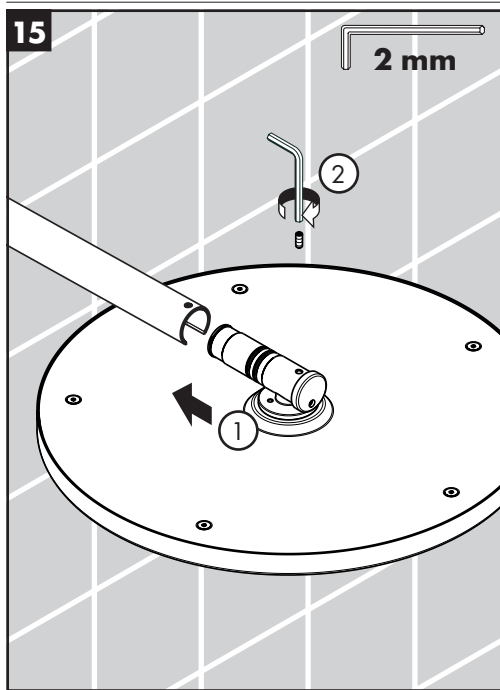

English

Install the showerhead on the shower arm.

Tighten the screw.

Level the shower arm.

Tighten the mounting screws.

Français

Installez la pomme de douche sur le bras de douche.

Serrez la vis.

Placez le bras de douche au niveau.

Serrez les vis de montage.

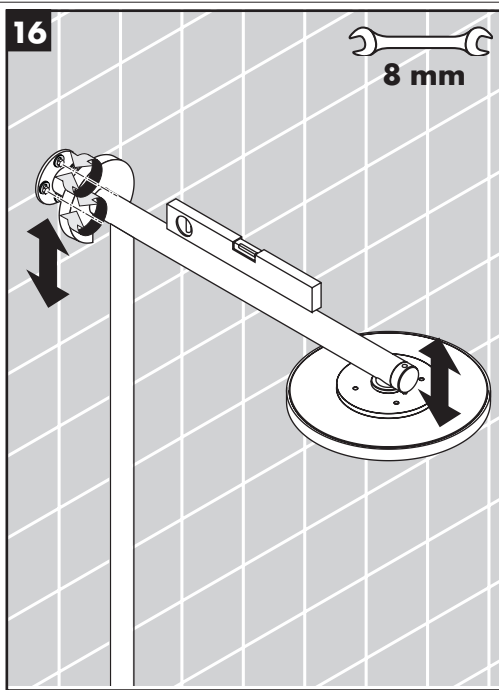

Español

Instale la ducha cabezal en el brazo de ducha.

Apriete el tornillo.

Nivele el brazo de ducha.

Apriete los tornillos de montaje.

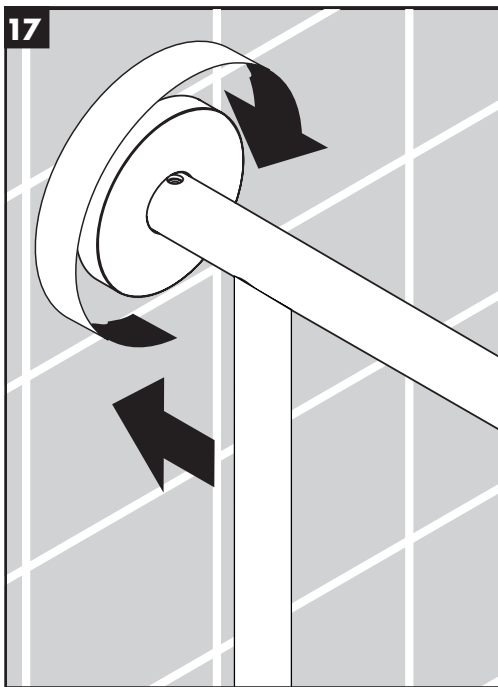

English

Connect the escutcheon to the mounting plate.

Place the black rubber hose washer in one end of the hose. Screw this end to the handshower port on the valve.

Place the screen washer in the other end of the hose. Screw this end to the handshower.

Place the handshower in the holder.

Français

Raccordez l'écusson à la plaque de montage.

Placez la rondelle de tuyau en caoutchouc noir dans l'une des extrémités du tuyau. Vissez cette extrémité du tuyau à la sortie pour douchette sur la valve.

Placez le tamis dans l'autre extrémité du tuyau. Vissez cette extrémité à la douchette.

Placez la douchette dans son support.

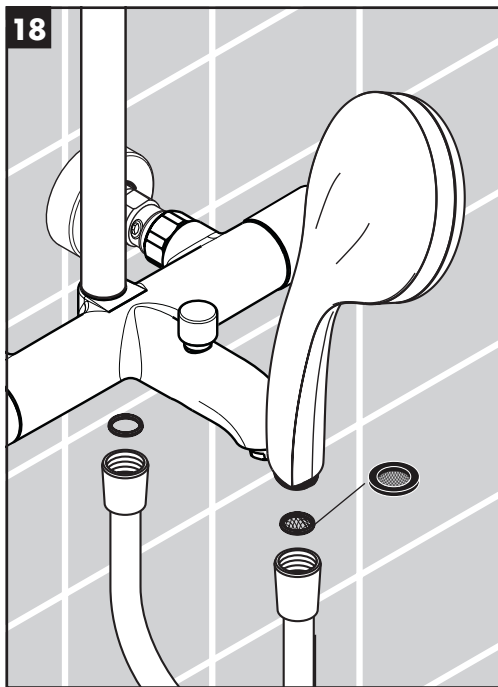

Español

Conecte el escudo a la placa de montaje.

Coloque la arandela de goma negra en un extremo de la manguera. Enrosque este extremo al puerto de la ducha de mano en la válvula.

Coloque la arandela de filtro en el otro extremo de la manguera. Enrosque este extremo a la ducha de mano.

Coloque la ducha de mano en el soporte.

Set the High Temperature Limit Stop (optional) / Réglage de la butée limite d'eau chaude (en option) / Ajuste el tope de límite de alta temperatura (opcional)

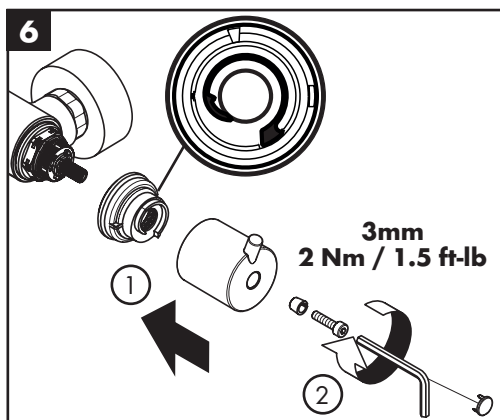
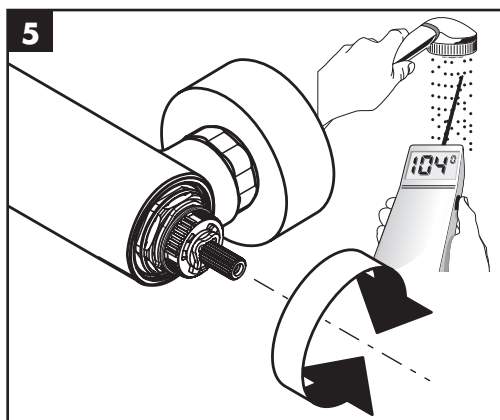
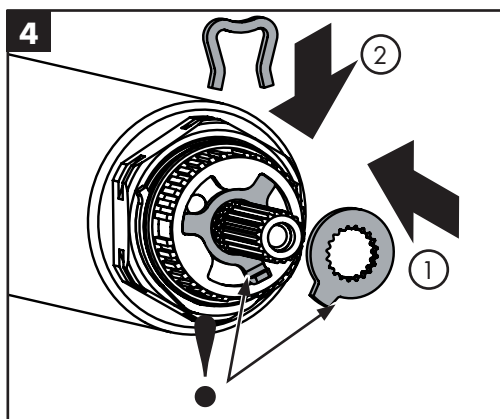
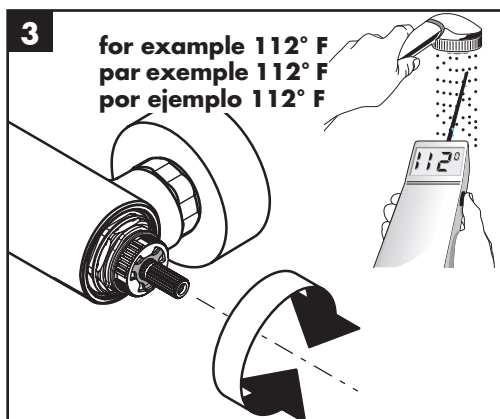
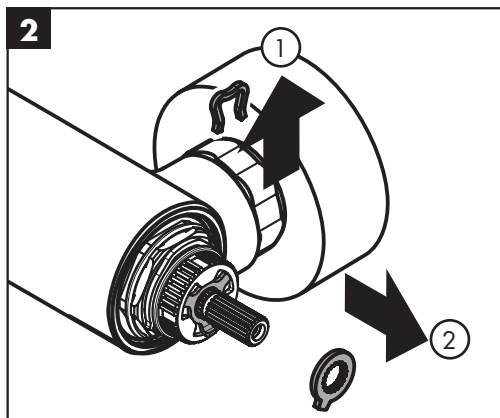
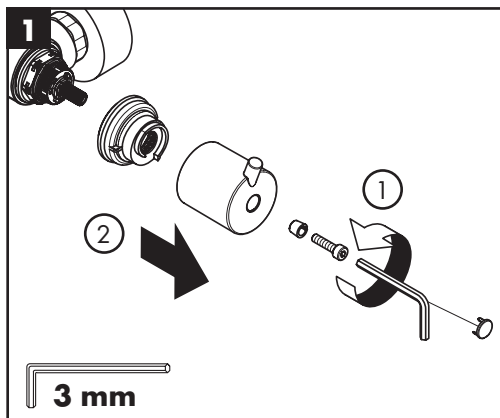

Replacement Parts / Pièces détachées / Repuestos

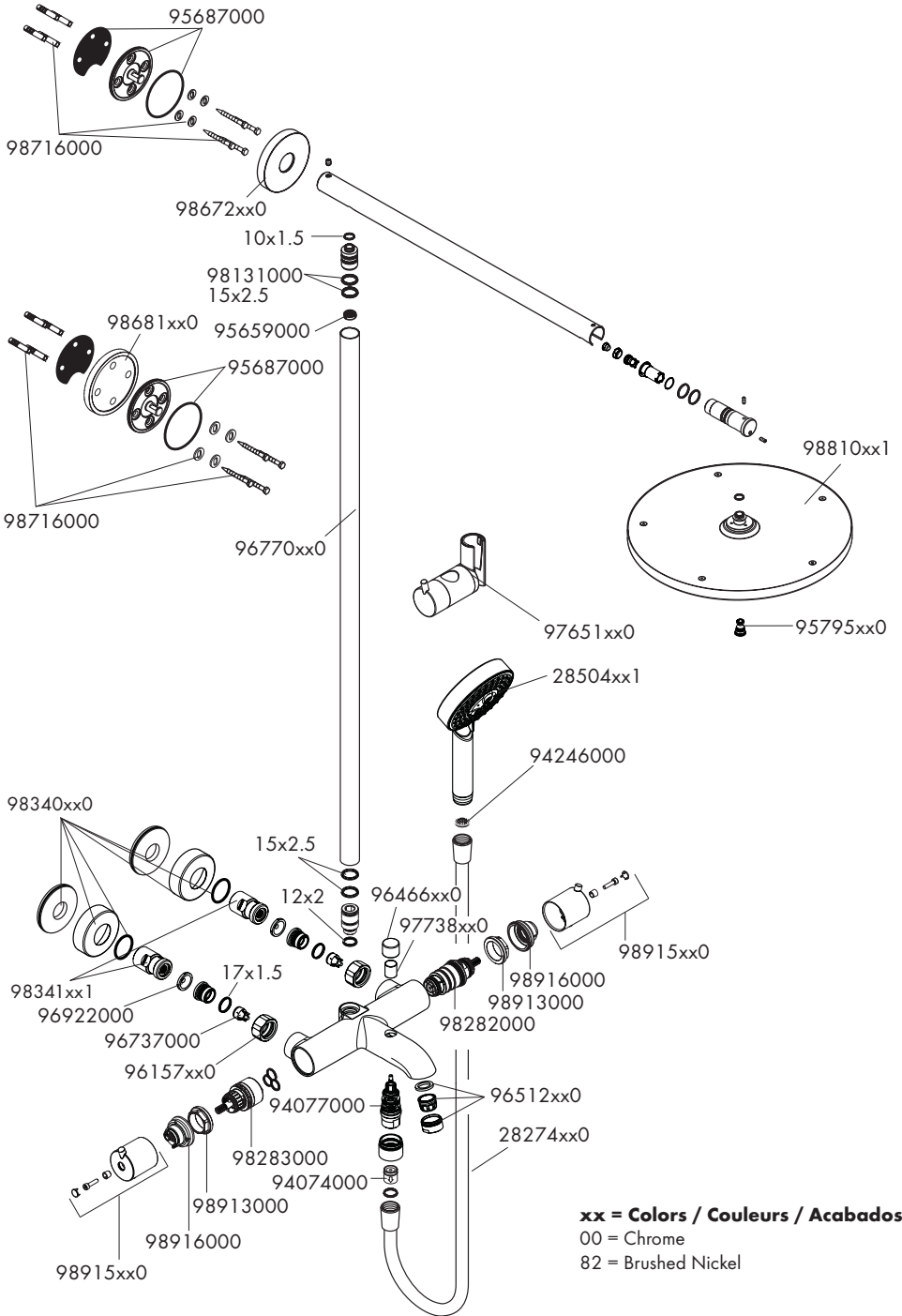

xx = Colors / Couleurs / Acabados
 00 = Chrome
 82 = Brushed Nickel

User Instructions / Instructions de service / Manejo

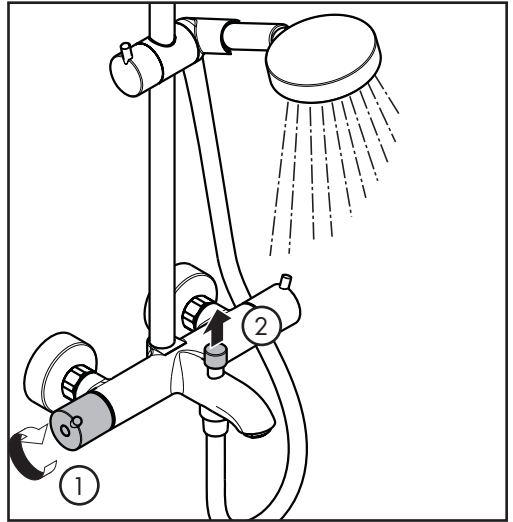
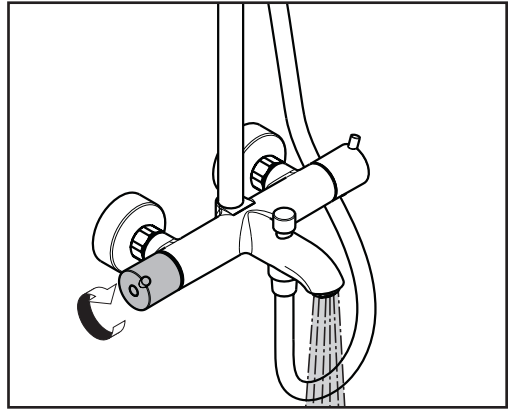
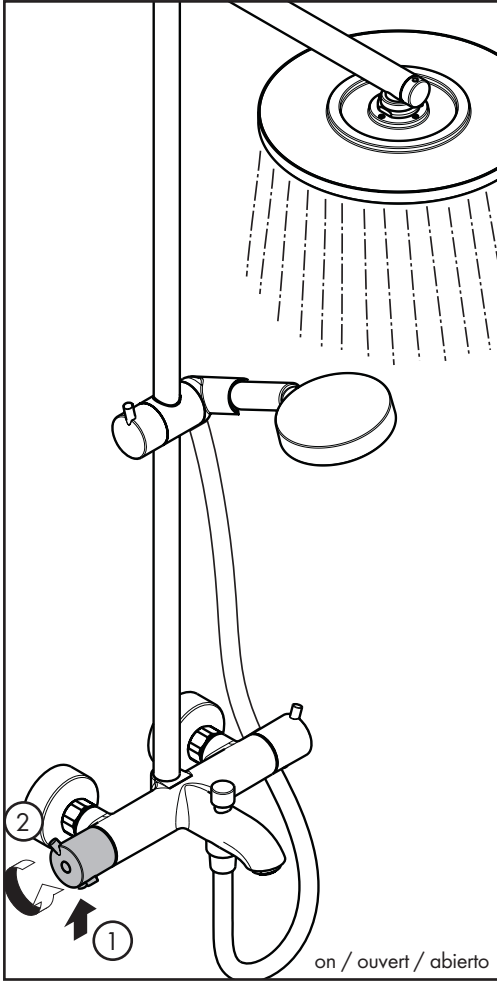

User Instructions / Instructions de service / Manejo

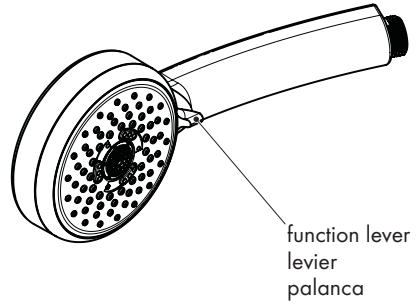
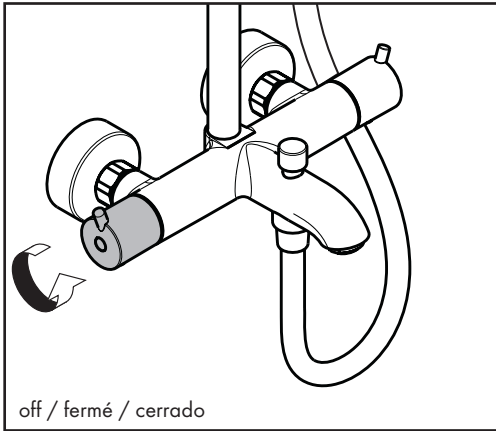
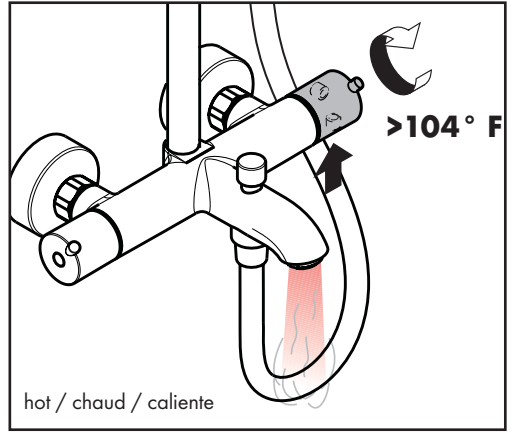
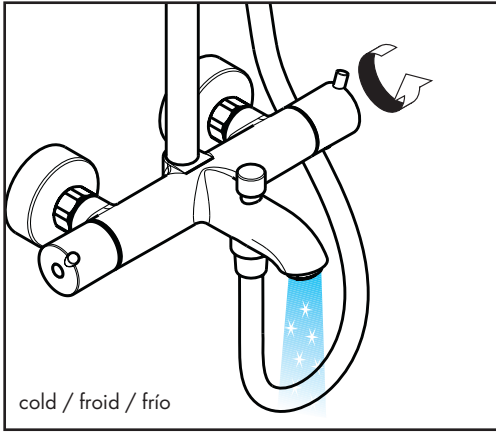

Cleaning / Nettoyage / Limpieza

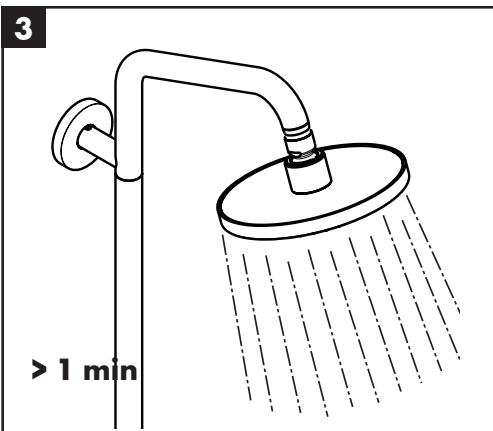
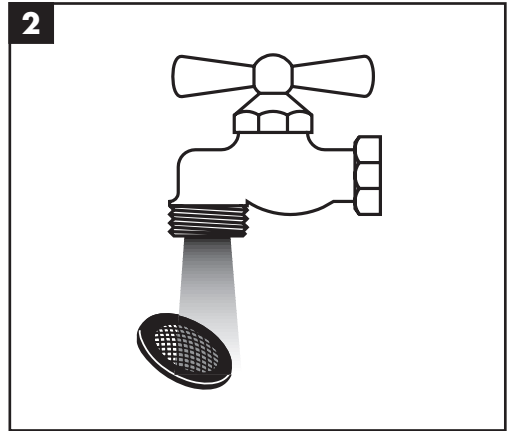
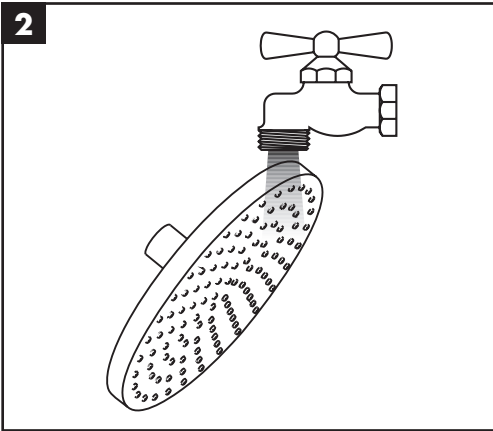
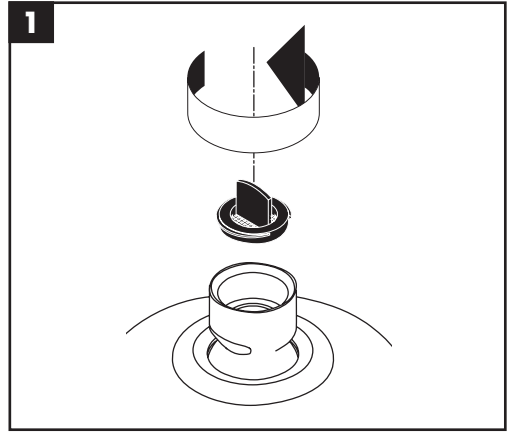
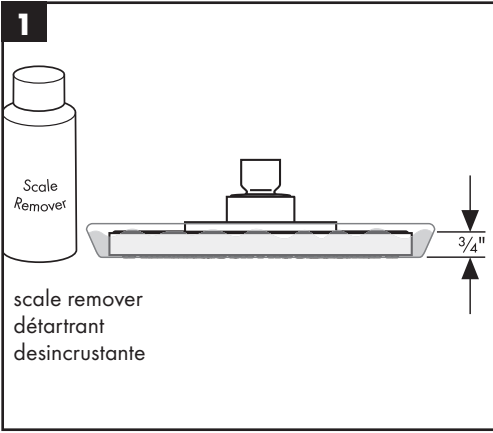

Cleaning / Nettoyage / Limpieza

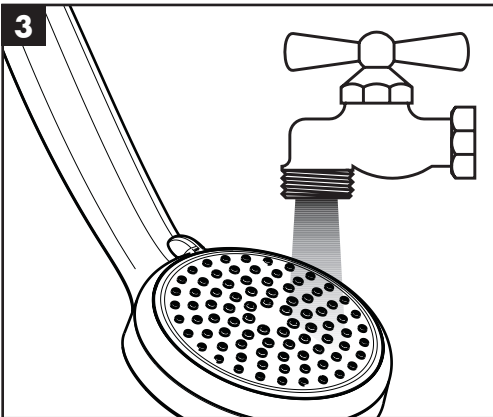
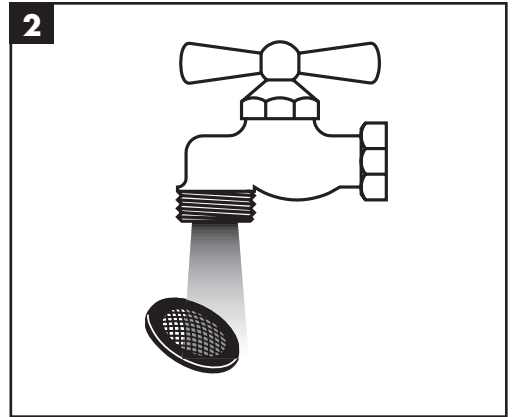
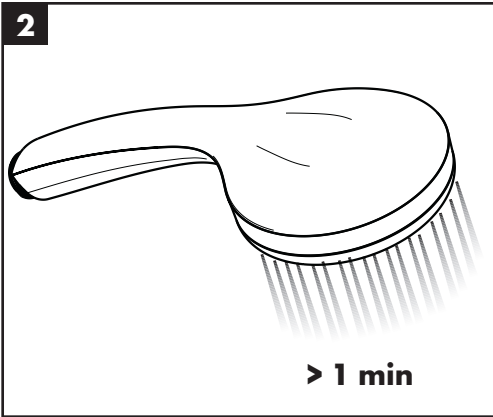
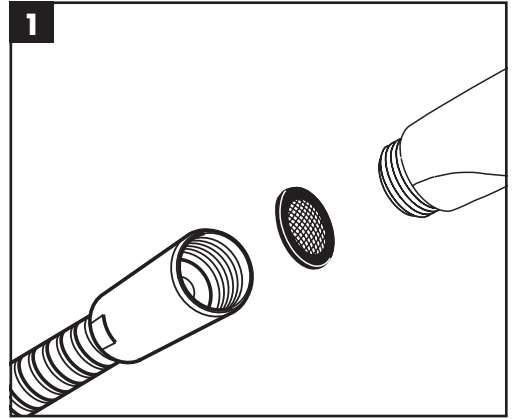
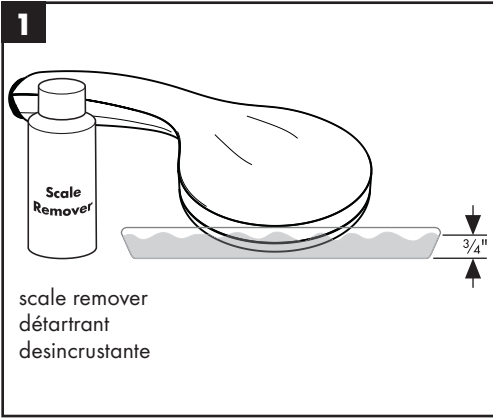

Check Valve Maintenance / Entretien / Mantenimiento

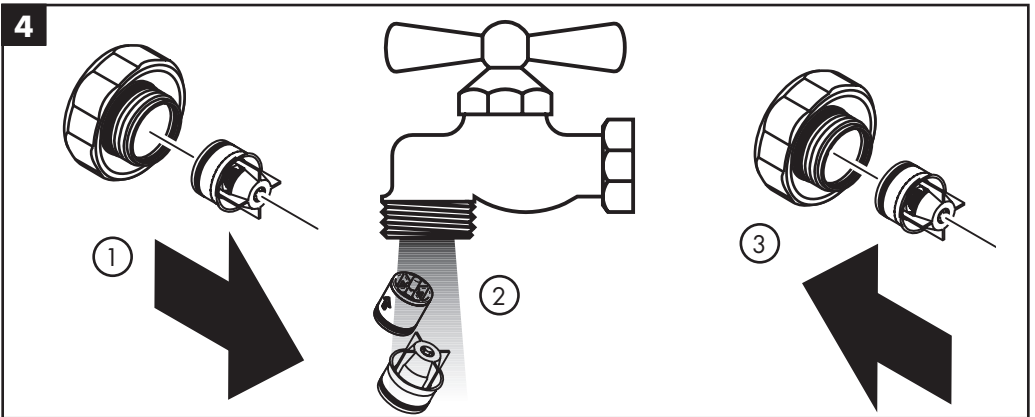
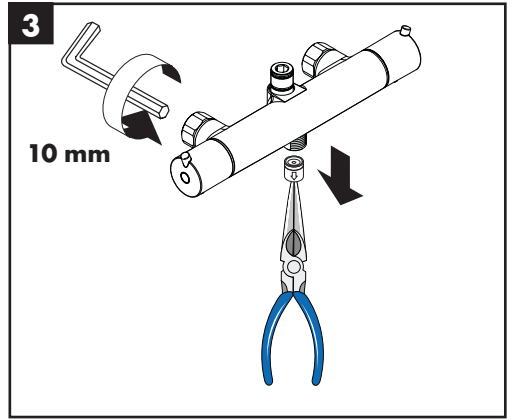
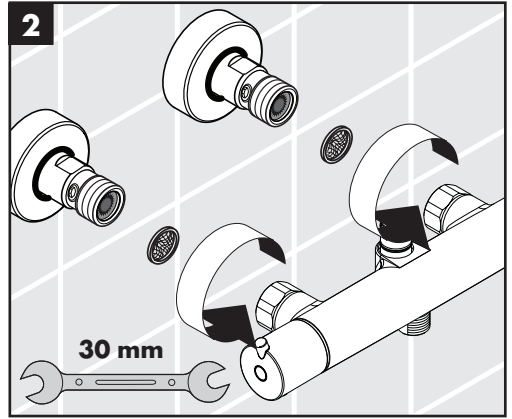
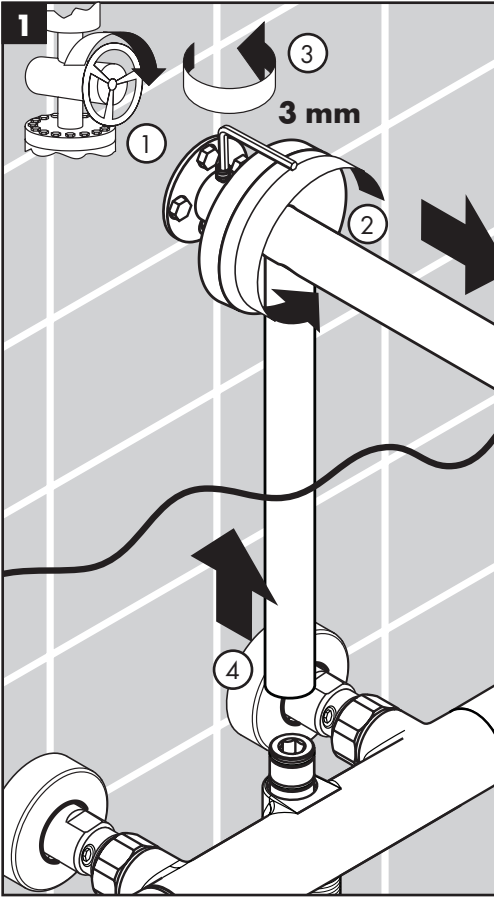

Check Valve Maintenance / Entretien / Mantenimiento

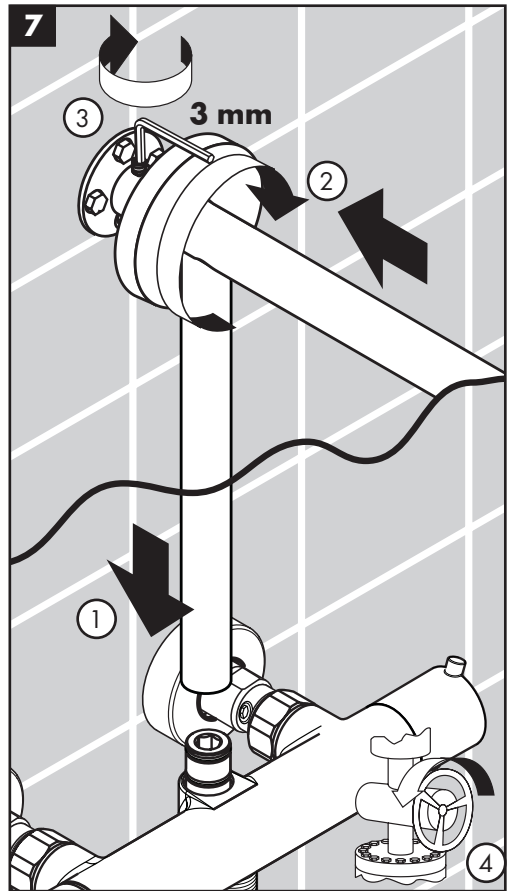
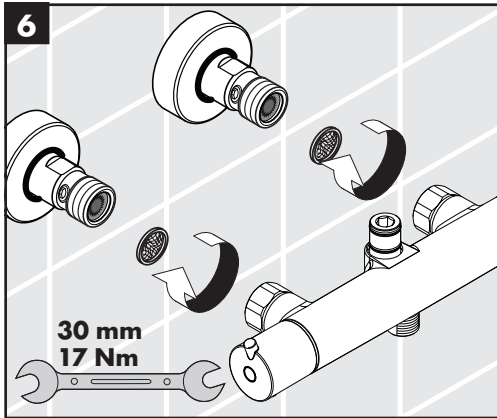
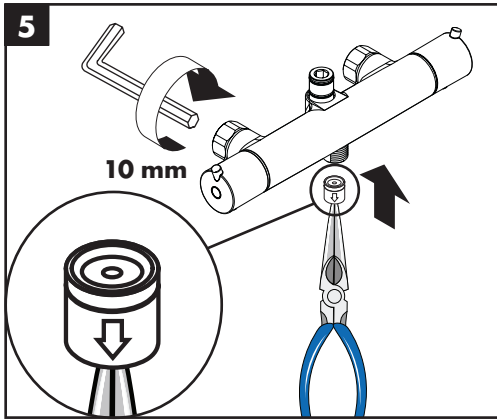

Troubleshooting

Fault	Cause	Remedy
Insufficient water	- Supply pressure inadequate	- Check water pressure (If a pump has been installed check to see if the pump is working).
	- Filters are dirty (96922000)	- Clean filters in front of the mixer and on the thermo cartridge
	- Shower filter seal dirty	- Clean filter seal between shower and hose
Crossflow: hot water being forced into cold water pipe, or vice versa, when mixer is closed	- Check valves dirty or worn	- Clean check valves, replace if necessary
Spout temperature does not correspond with temperature set	- Thermostat has not been adjusted	- Adjust thermostat
	- Hot water temperature too low	- Increase hot water temperature to 120 °F to 140 °F
Temperature regulation not possible	- thermo cartridge dirty or worn	- Replace thermo cartridge
	- hot and cold supplies are reversed	- NOT A PRODUCT DEFECT: correct the plumbing
Instantaneous heater didn't work with thermostat	- Filters are dirty	- Clean the filter / exchange filter
	- Check valve(s) dirty or worn	- Replace check valves

Dépannage

Dysfonctionnement	Origine	Solution
Pas assez d'eau	- Pression d'alimentation insuffisante	- Contrôler la pression
	- Filtres encrassés (96922000)	- Nettoyer les filtres devant le mitigeur thermostatique et sur la cartouche (96922000)
	- Joint-filtre de douche encrassé	- Nettoyer le joint-filtre entre la douche et le flexible
Circulation opposée, l'eau chaude est comprimée dans l'arrivée d'eau froide et vice versa avec robinet fermé	- Clapet anti-retour encrassé ou défectueux	- Nettoyer le clapet anti-retour ou le changer éventuellement
La température à la sortie ne correspond pas à la température de réglage	- Le thermostat n'a pas été réglé	- Régler le thermostat
	- Température d'eau chaude trop basse, pas d'eau froide	- Augmenter la température d'eau chaude entre 42°C et 65°C
Le réglage de la température n'est pas possible	- Cartouche thermostatique entartrée	- Changer la cartouche thermostatique
Le chauffe-eau instantané ne s'allume pas lors de l'utilisation du thermostat	- Filtres encrassés	- Nettoyez / changez les filtres
	- Clapet anti-retour bloqué	- Changez le clapet antiretour

Localización de fallas

Problema	Causa	Solución
Sale poca agua	- presión insuficiente	- comprobar presión
	- filtro de la ducha sucio (96922000)	- limpiar filtro entre flexo y ducha (96922000)
	- filtro de la ducha sucio	- limpiar/cambiar filtros entre flexo y ducha
Flujo de agua cruzada agua caliente entra en la tubería del agua fría o al revés	- válvula antirretorno sucia o pierde	- limpiar / cambiar válvula
Temperatura del agua no corresponde a lo marcado	- termostato no ha sido ajustado	- ajustar termostato
	- Temperatura del agua demasiado baja no hay	- aumentar temperatura del agua caliente a 42° - 65° C.
No es posible regular la temperatura	- termoelemento calcificadat	- cambiar termoelemento
Calentador instantáneo no se enciende en combinación con el termostato	- filtro de la ducha sucio	- limpiar/cambiar filtros
	- válvula anti-retorno cerrada	- cambiar válvula anti-retorno

Cleaning Recommendation for Hansgrohe Products

Modern bathroom faucets, kitchen faucets and shower products are made from different materials to comply with the needs of the market with regard to design and functionality. To avoid damage to the product, it is necessary to take proper care of it.

For best results:

- Prevent the buildup of mineral scale and /or soap residue by cleaning your Hansgrohe product(s) when needed.
- Select a cleaning agent specifically intended for the type of product.
- **Do not** use these types of cleaners as they will cause damage to your Hansgrohe product:
 - ✘ Any cleaning agent containing hydrochloric acid, formic acid, lye, or acetic acid.
 - ✘ Abrasive cleaning powders, pads, or brushes.
 - ✘ Steam cleaners.
 - ✘ "No rinse" cleaning agents.
- **Always** follow the instructions provided by the manufacturer of the cleaning agent.
- **Do not** mix cleaning agents, unless directed by the manufacturer.
- **Do not** spray cleaners directly onto the product as drops could enter openings and gaps and cause damage. When using spray cleaners, spray the cleaner onto a soft cloth or sponge.
- **Always** rinse your Hansgrohe product thoroughly with clear water and polish dry with a soft cloth after cleaning.

Important

- Residue from soaps and shampoos can cause damage. Rinse the product with clean water after each use.
- Residue from basin/tub/tile cleaner can cause damage to faucets and fittings. Immediately rinse any overspray from the Hansgrohe product.
- **Damage to the product caused by improper care or the use of improper cleaning agents is not covered by the warranty.**
- **If a component of the product is damaged, replace it, as there is risk of injury.**

Conseil de nettoyage pour les produits Hansgrohe

Les robinets pour les salles de bains et les cuisines modernes ainsi que les produits récents pour les douches se composent de matériaux différents afin de satisfaire aux besoins du marché en termes de conception et de fonctionnalité. Afin d'éviter d'endommager le produit, il est nécessaire d'en prendre soin.

Pour de meilleurs résultats :

- Empêchez l'accumulation de tarte et/ou de résidu de savon en nettoyant votre produit Hansgrohe lorsque c'est nécessaire.
- Sélectionnez un produit de nettoyage spécifiquement prévu pour ce type de produit.
- **N'utilisez pas** ces types de nettoyeurs car ils peuvent endommager votre produit Hansgrohe :
 - ✘ Tout produit de nettoyage contenant de l'acide chlorhydrique, de l'acide formique, de la potasse ou de l'acide acétique.
 - ✘ Les poudres de nettoyage, les tampons ou les brosses abrasives.
 - ✘ Les nettoyeurs à vapeur.
 - ✘ Les produits de nettoyage « sans rinçage ».
- **Ne mélangez pas** les produits de nettoyage, à moins que cela soit indiqué par le fabricant.

-
- **Ne pulvérisez pas** les nettoyants directement sur le produit car des gouttes pourraient entrer dans les ouvertures et les fentes et causer des dommages. Lorsque vous utilisez des nettoyants par pulvérisation, pulvérisez le nettoyant sur un chiffon ou une éponge douce.

Important

- Le résidu provenant des savons et des shampoings peut causer des dommages. Rincez le produit avec de l'eau propre après chaque utilisation.
- Le résidu provenant des nettoyants pour cuvette/baignoire/carrelage peut endommager les robinets et les raccords de tuyauterie. Rincez immédiatement toute surpulvérisation sur le produit Hansgrohe.
- **Les dommages au produit causés par un mauvais entretien ou par l'utilisation de produits de nettoyage inadéquats ne sont pas couverts par la garantie.**
- **Si un composant du produit est endommagé, remplacez-le, car il existe un risque de blessure.**

Recomendación de limpieza para los productos de Hansgrohe

Hoy en día, las griferías de baño y de cocina así como duchas modernas se componen de materiales muy distintos para satisfacer las exigencias del mercado respecto al diseño y la funcionalidad. Para evitar daños y reclamaciones hay que tener en cuenta ciertos aspectos tanto en el uso como en su limpieza.

Para obtener mejores resultados:

- Evite la acumulación de restos de jabón o sarro limpiando el producto Hansgrohe cuando sea necesario.
- Seleccione un agente de limpieza diseñado específicamente para el tipo de producto.
- **No** use estos tipos de limpiadores, ya que causarán daño a su producto Hansgrohe:
 - ✘ Agentes limpiadores que contengan ácido clorhídrico, fórmico, acético o lejía.
 - ✘ Polvos, paños o cepillos de limpieza abrasivos.
 - ✘ Limpiadores a vapor
 - ✘ Agentes de limpieza "sin enjuague".
- **Siempre** siga las instrucciones provistas por el fabricante del agente de limpieza.
- **No** mezcle los agentes de limpieza, a menos que esté indicado por el fabricante.
- **No** rocíe limpiadores directamente sobre el producto, ya que podrían caer gotas sobre las aberturas y espacios y causar daños. Cuando use limpiadores en spray, rocíe el limpiador sobre un paño suave o esponja.
- **Siempre** enjuague su producto Hansgrohe con agua limpia y séquelo y lístrelolo con un paño suave después de la limpieza.

Importante

- Los residuos de jabón y champú pueden causar daños. Enjuague el producto con agua limpia después de cada uso.
- Los residuos de limpiadores para lavatorios, bañeras o azulejos pueden causar daño a los grifos y accesorios. Enjuague inmediatamente cualquier derrame que haya sobre el producto de Hansgrohe.
- **Los daños que resulten de un cuidado inadecuado o uso de agentes de limpieza inadecuados no están cubiertos por la garantía**
- Si se daña un componente del producto, reemplácelo, ya que existe riesgo de lesión.

Limited Consumer Warranty

This product has been manufactured and tested to the highest quality standards by Hansgrohe, Inc. (“Hansgrohe”). This warranty is limited to Hansgrohe products that are purchased by a consumer in the United States or Canada after March 1, 1996, and installed in either in the United States or in Canada.

WHO IS COVERED BY THE WARRANTY

This warranty extends to the original purchaser only. This warranty is non-transferable.

WHAT IS COVERED BY THE WARRANTY

The warranty covers only your Hansgrohe manufactured product. Hansgrohe warrants this product against defects in material or workmanship as follows:

Hansgrohe will replace at no charge for parts only or, at its option, replace any product or part of the product that proves defective because of improper workmanship and/or material, under normal installation, use, service and maintenance. If Hansgrohe is unable to provide a replacement and repair is not practical or cannot be made in timely fashion, Hansgrohe may elect to refund the purchase price in exchange for the return of the product.

LENGTH OF WARRANTY

Replacement or repaired parts of products will be covered for the term of this warranty, as stated in the following two sentences. If you are a consumer who purchased the product for use primarily for personal, family or household purposes, this warranty extends for as long as you own the product and the home in which the product is originally installed. If you purchased the product for use primarily for any other purpose, including, without limitation, a commercial purpose, this warranty extends only (i) for 1 year, with respect to Hansgrohe & Commercial products, and (ii) for 5 years, with respect to Axor products.

THIS WARRANTY DOES NOT COVER, AND HANSGROHE WILL NOT PAY FOR:

- A. Conditions, malfunctions or damage not resulting from defects in material or workmanship.
- B. Conditions, malfunctions or damage resulting from (1) normal wear and tear, improper installation, improper maintenance, misuse, abuse, negligence, accident or alteration; (2) the use of abrasive or caustic cleaning agents or “no-rinse” cleaning products, or the use of the product in any manner contrary to the product instructions; or (3) conditions in the home such as excessive water pressure or corrosion.
- C. Labor and other expenses for disconnection, deinstallation, or return of the product for warranty service (including but not limited to proper packaging and shipping costs), or for installation or reinstallation of the product.
- D. Accessories, connected materials and products, or related products not manufactured by Hansgrohe.
- E. Any Hansgrohe or Axor product sold for display purposes.
- F. Rubbed Bronze finish is subject to a 3-year limited warranty. Chrome and all PVD finishes are covered by the limited lifetime warranty.
- G. Hansgrohe Water Filtration System is subject to a 1-year limited warranty. Warranty does not include replacement filters.

TO OBTAIN WARRANTY PARTS OR INFORMATION

Contact your Hansgrohe retailer, or contact Technical Service at:

Hansgrohe, Inc.
1492 Bluegrass Lakes Parkway
Alpharetta, GA 30004
Toll-free 800-334-0455

In requesting warranty service, you will need to provide:

1. The sales receipt or other evidence of the date and place of purchase.
2. A description of the problem.
3. Delivery of the product or the defective part, postage prepaid and carefully packed and insured, to:

Hansgrohe, Inc.
1492 Bluegrass Lakes Parkway
Alpharetta, GA 30004
Toll-free 800-334-0455

When warranty service is completed, any repaired or replacement product or part will be returned to you postage prepaid.

EXCLUSIONS AND LIMITATIONS

REPAIR OR REPLACEMENT (OR, IN LIMITED CIRCUMSTANCES, REFUND OF THE PURCHASE PRICE) AS PROVIDED UNDER THIS WARRANTY IS THE EXCLUSIVE REMEDY OF THE PURCHASER. HANSGROHE NEITHER ASSUMES NOR AUTHORIZES ANY PERSON TO CREATE FOR IT ANY OTHER OBLIGATION OR LIABILITY IN CONNECTION WITH THIS PRODUCT. HANSGROHE SHALL NOT BE LIABLE TO PURCHASER OR ANY OTHER PERSON FOR ANY INCIDENTAL, SPECIAL OR CONSEQUENTIAL DAMAGES, ARISING OUT OF BREACH OF THIS WARRANTY OR ANY IMPLIED WARRANTY (INCLUDING BUT NOT LIMITED TO ANY IMPLIED WARRANTY OF MERCHANTABILITY).

Some States do not allow the exclusion or limitation of incidental or consequential damages, so the above limitation or exclusion may not apply to you. This warranty gives you specific legal rights, and you may also have other rights that vary from state to state.

TO THE EXTENT PERMITTED BY LAW, ANY IMPLIED WARRANTIES OF MERCHANTABILITY AND FITNESS FOR A PARTICULAR PURPOSE, ARE LIMITED TO THE DURATION OF THE EXPRESS WARRANTY.

Some states do not allow limitations on how long an implied warranty may last, so the above limitations may not apply to you. You may be required by law to give us a reasonable opportunity to correct or cure any failure to comply before you can bring any action in court against us under the Magnuson-Moss Warranty Act.

PRODUCT INSTRUCTIONS AND QUESTIONS

Upon purchase or prior to installation, please carefully inspect your Hansgrohe product for any damage or visible defect. Prior to installing, always carefully study the enclosed instructions on the proper installation and the care and maintenance of this product. If you have questions at any time about the use, installation or performance of your Hansgrohe product, or this warranty, please write us or call us toll-free at 800-334-0455.

hansgrohe

Hansgrohe, Inc. • 1490 Bluegrass Lakes Parkway • Alpharetta, GA 30004
Tel. 800-334-0455 • Fax 770-360-9887

www.hansgrohe-usa.com