

AXOR[®]

hansgrohe

- EN** Installation / User Instructions / Warranty
- FR** Instructions de montage / Mode d'emploi / Garantie
- ES** Instrucciones de montaje / Manejo / Garantía

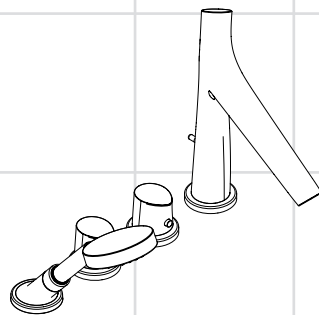

Starck Organic
12425001

Technical Information

Recommended water pressure	15 - 75 PSI
Max. water pressure	145 PSI
Recommended hot water temp.	120° - 140° F*
Max. hot water temp	176° F*
Flow rate - handshower	2.0 GPM
Flow rate - tub spout	4.8 GPM @ 44 PSI

*Please know and follow all applicable local plumbing codes when setting the temperature on the water heater.

Installation Considerations

- For best results, Hansgrohe recommends that this unit be installed by a licensed, professional plumber.
- Please read over these instructions thoroughly before beginning installation. Make sure that you have all tools and supplies needed to complete the installation.
- This trim kit requires rough valve 15460181 (not included).
- Protection against backflow is provided by a check valve in the handshower hose and by an automatically resetting diverter.
- This thermostatic mixing valve is for use with shower heads rated at 2.5 GPM (9.5 L/min) or higher.
- This handshower is for use with automatic compensating valves rated at 1.7 GPM (6.4 L/min.) or less.
- Keep this booklet and the receipt (or other proof of date and place of purchase) for this product in a safe place. The receipt is required should it be necessary to request warranty parts.

Données techniques

Pression d'eau recommandée	15 - 75 PSI
Pression d'eau maximum	145 PSI
Température recommandée d'eau chaude	120° - 140° F*
Température maximum d'eau chaude	176° F*
Capacité nominale - douchette	2.0 GPM
Capacité nominale - bec	4.8 GPM @ 44 PSI

* Vous devez connaître et respecter tous les codes de plomberie locaux applicables pour le réglage de la température du chauffe-eau.

À prendre en considération pour l'installation

- Pour de meilleurs résultats, Hansgrohe recommande que ce produit soit installé par un plombier professionnel licencié.
- Veuillez lire attentivement ces instructions avant de procéder à l'installation. Assurez-vous de disposer de tous les outils et du matériel nécessaires pour l'installation.
- L'ensemble de robinetterie requière l'utilisation de la pièce de surface 15460181 (non comprise).
- La protection contre le retour d'eau est assurée par un clapet anti-retour et un dispositif de dérivation à réenclenchement automatique.
- Ce produit devrait être seulement utilisé avec les pommes de douche évaluées à 2.5 GPM (9.5 L/min) ou plus.
- Cette pomme de douche doit être utilisée avec une soupape qui compense automatiquement, et est évalué à 1.7 GPM (6.4 L/min.) ou moins.
- Conservez ce livret et le reçu (ou une autre preuve sur laquelle figurent la date et l'endroit de l'achat) pour ce produit dans un endroit sûr. Le reçu est requis si vous commandez des pièces sous garantie.

Datos técnicos

Presión recomendada en servicio	15 - 75 PSI
Presión en servicio max.	145 PSI
Temperatura recomendada del agua caliente	120° - 140° F*
Temperatura del agua caliente max.	176° F*
Caudal máximo - teleducha	2.0 GPM
Caudal máximo - surtidor	4.8 GPM @44 PSI

*Debe conocer y cumplir todos los códigos locales aplicables para ajustar la temperatura del calentador de agua.

Consideraciones para la instalación

- Para obtener mejores resultados, la instalación debe estar a cargo de un plomero profesional matriculado.
- Antes de comenzar la instalación, lea estas instrucciones detenidamente. Asegúrese de tener las herramientas y los insumos necesarios para completar la instalación.
- El juego de pieza exterior requiere la pieza interior 15460181 (no incluida).
- Una válvula antirretorno en el codo de la teleducha y un distribuidor que se reajusta automáticamente brindan protección contra el contraflujo.
- Esta ducha cabezal es debe ser utilizada con una válvula que compensa automáticamente, y es valorado en 1.7 GPM (6.4 L/min.) o menos.
- Este producto debe ser utilizado sólo con alcachofas de la ducha valoradas en 2.5 GPM (9.5 L/min) o más.
- Esta ducha cabezal es debe ser utilizada con una válvula que compensa automáticamente, y es valorado en 1.7 GPM (6.4 L/min.) o menos.
- Mantenga este folleto y el recibo (u otro comprobante del lugar y fecha de compra) de este producto en lugar seguro. El recibo se requiere en caso de ser necesario solicitar piezas bajo garantía.

Tools Required / Outils Utiles / Herramientas Útiles

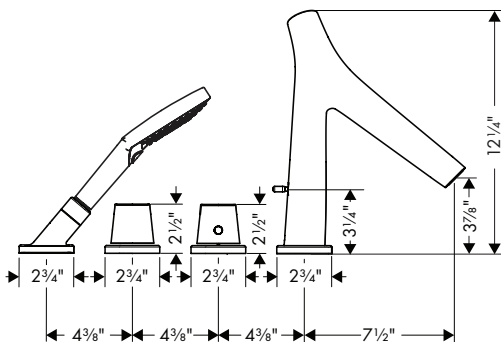
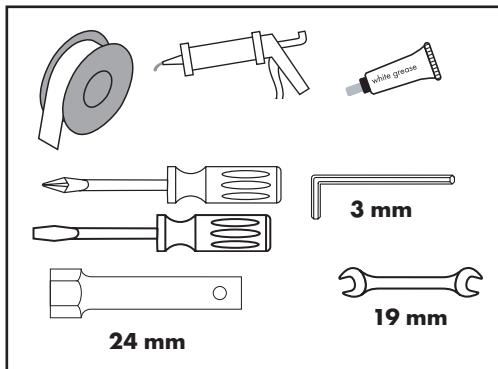

Installation / Installation / Instalación

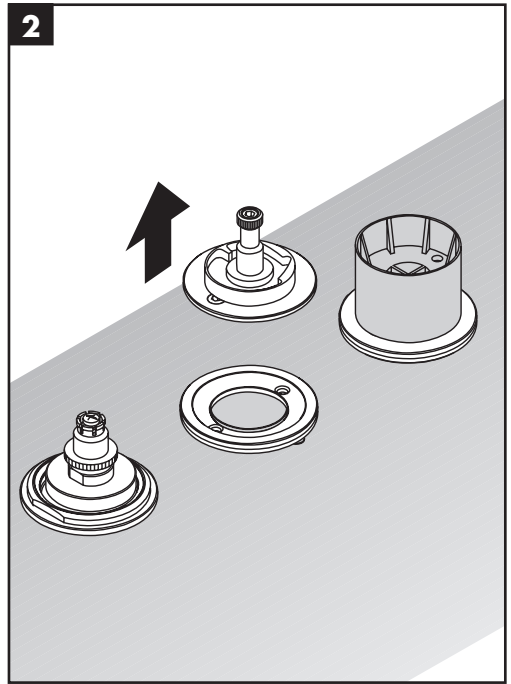
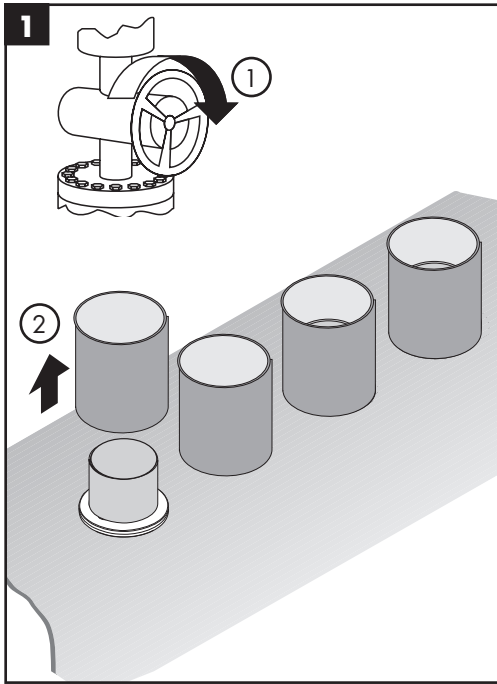

English

Turn the water off at the main.

Remove the plastic tubes.

Remove the safety set.

Français

Fermez l'eau à la valve principale.

Retirez les tubes en plastique.

Retirez l'ensemble de sécurité.

Español

Cierre el paso del agua en la entrada del suministro.

Retire los tubos plásticos.

Retire el equipo de seguridad.

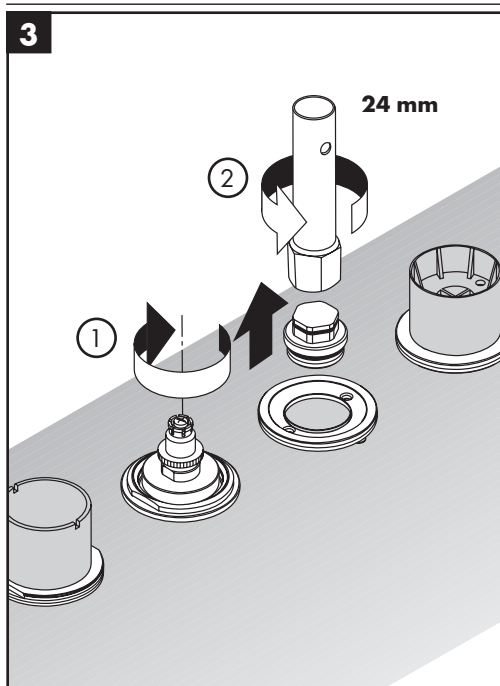

English

Turn the diverter to the off position.

Remove the nut.

Install the thermostatic cartridge and the handle adapter.

Français

Tournez le dispositif de dérivation à sa position d'arrêt.

Retirez l'écrou.

Installez la cartouche thermostatique et l'adaptateur pour poignée.

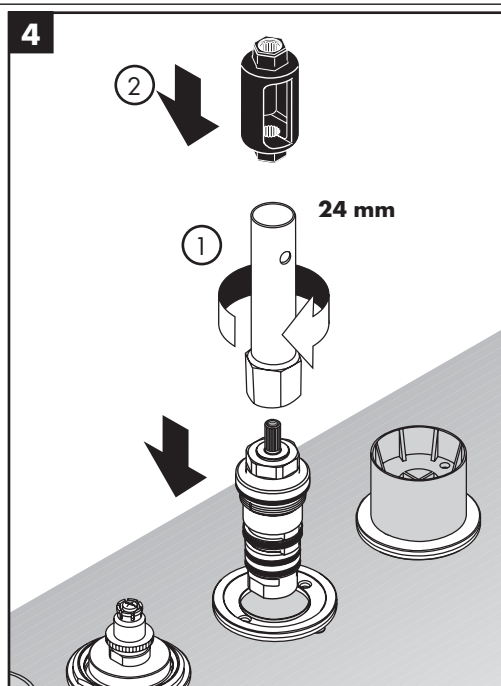

Español

Gire el distribuidor a la posición cerrada.

Retire la tuerca.

Instale el cartucho termostático y el adaptador mando.

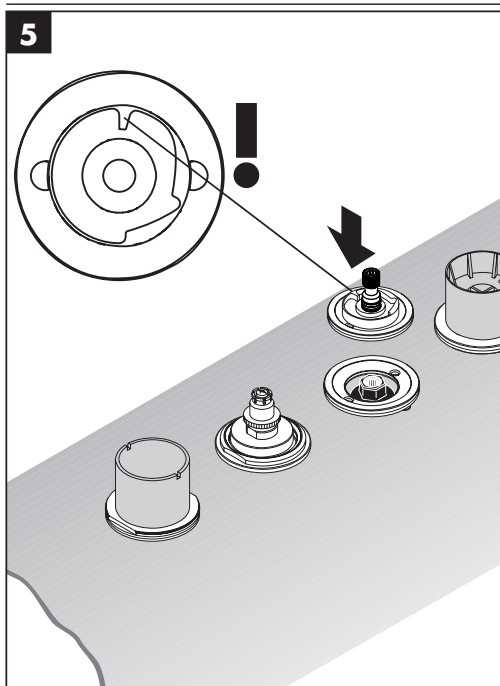

English

Install the safety set with the notch oriented as shown in the diagram.

Grease the threads lightly with white plumbers' grease.

Install the escutcheons.

Install the volume control handle.

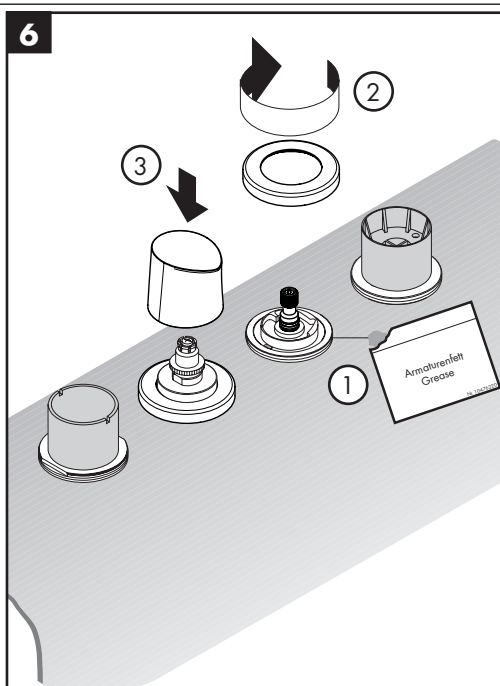

Español

Instale el equipo de seguridad con la ranura orientada como se muestra en el dibujo.

Lubrique las roscas levemente con grasa blanca para plomería.

Instale los escudos.

Instale la manija del llave de paso.

Français

Installez l'ensemble de sécurité de façon à ce que l'encoche soit orientée comme indiqué sur le schéma.

Lubrifiez légèrement les filets en utilisant de la graisse de plomberie blanche.

Installez les écussons.

Installez la poignée du robinet d'arrêt.

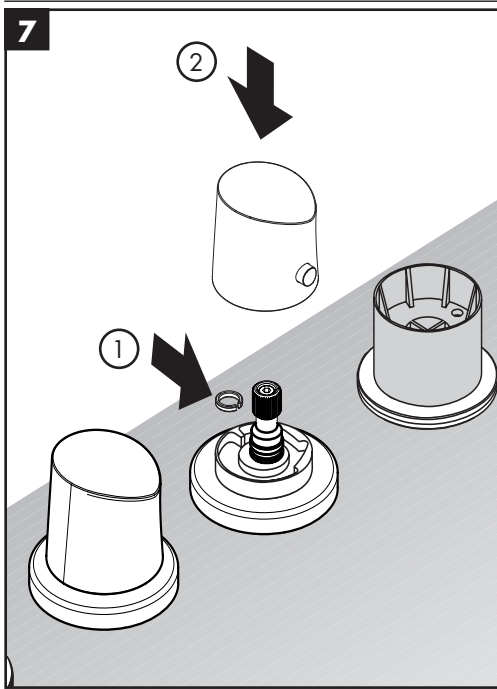

English

Install the thermostatic handle.

Remove the plaster shield and seal from the diverter housing.

Français

Installez la poignée thermostatique.

Retirez le protecteur et le joint du compartiment du dispositif de dérivation.

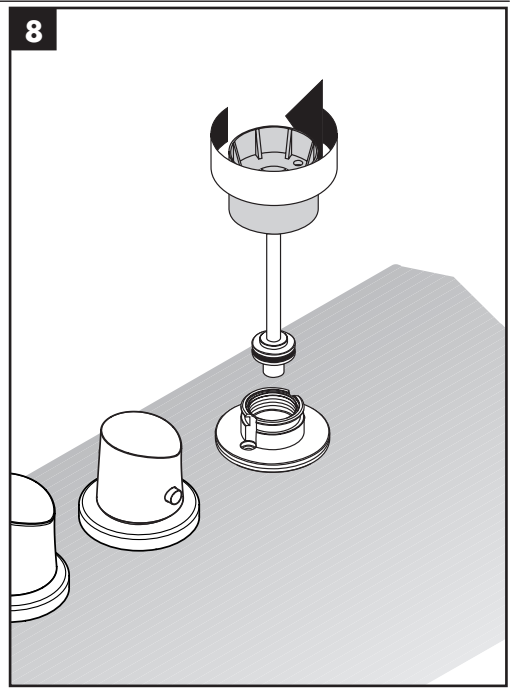

Español

Instale la manija del mezclador termostático.

Retire el protector de yeso y el sello del alojamiento del distribuidor.

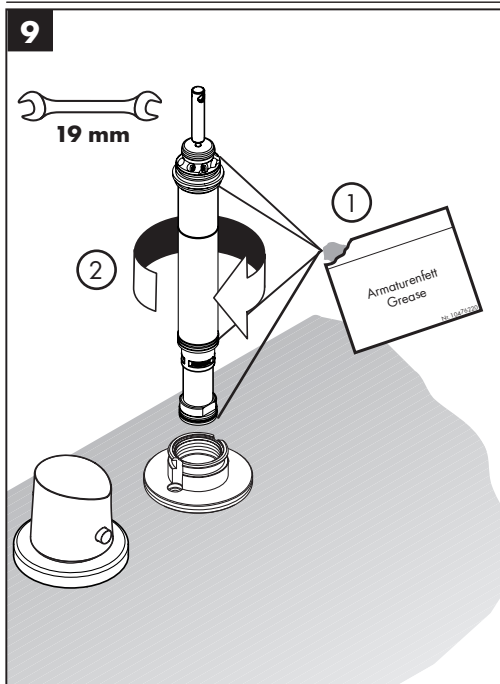

English

Lightly grease the o-rings on the diverter with white plumbers' grease.

Install the diverter.

⚠ Do not over-tighten the diverter.

Lightly lubricate the threads on the diverter housing using white plumbers' grease.

Install the spout escutcheon.

Install the spout.

Français

Lubrifiez légèrement les joints toriques sur le dispositif de dérivation en utilisant de la graisse de plomberie blanche.

Installez le dispositif de dérivation.

⚠ Ne serrez pas trop l'inverseur!

Lubrifiez légèrement les filets sur le compartiment du dispositif de dérivation en utilisant de la graisse de plomberie blanche.

Installez la rosace du bec.

Installez le bec.

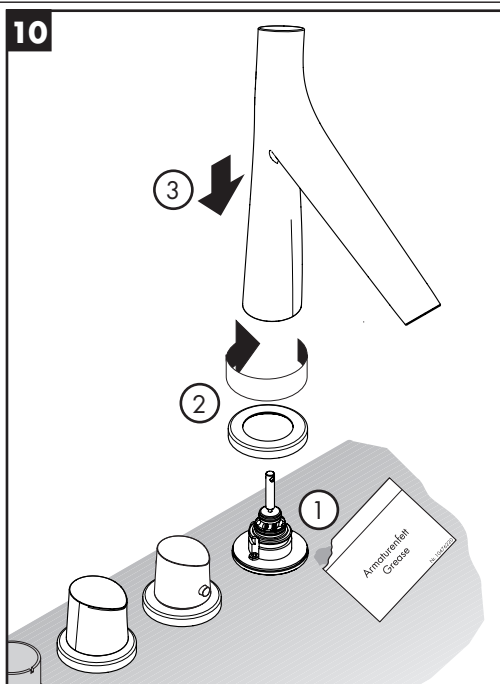

Español

Lubrique levemente los retenes anulares del distribuidor con grasa blanca para plomería.

Instale el distribuidor.

⚠ No ajuste demasiado el distribuidor.

Lubrique levemente las roscas del alojamiento del distribuidor con grasa blanca para plomería.

Instale el escudo del surtidor.

Instale el surtidor.

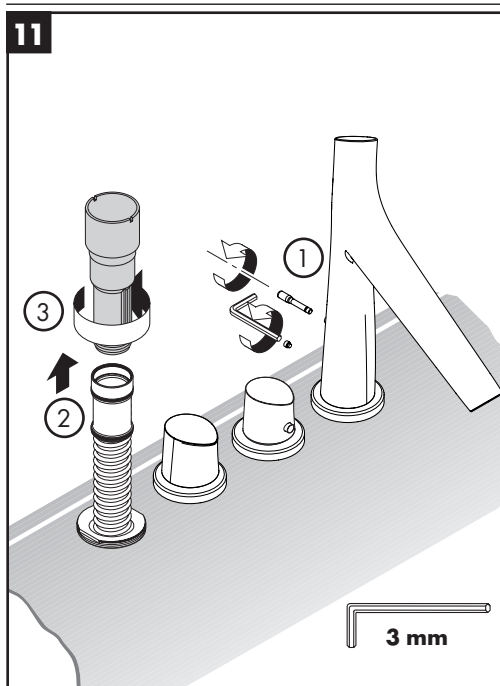

English

Install the diverter rod.

Tighten the spout screw.

Pull the Secuflex hose away from the rough.

Remove the plaster shield.

Remove the Secuflex hose from the rough.

Disconnect the Secuflex hose from the high pressure hose by loosening the white plastic nut.

Français

Installez la tige de l'inverseur.

Serrez la vis du bec.

Tirez le tuyau Secuflex hors de la pièce intérieure.

Retirez le protecteur.

Retirez le tuyau Secuflex de la pièce intérieure.

Débranchez le tuyau Secuflex du tuyau à haute pression en dévissant l'écrou de plastique blanc.

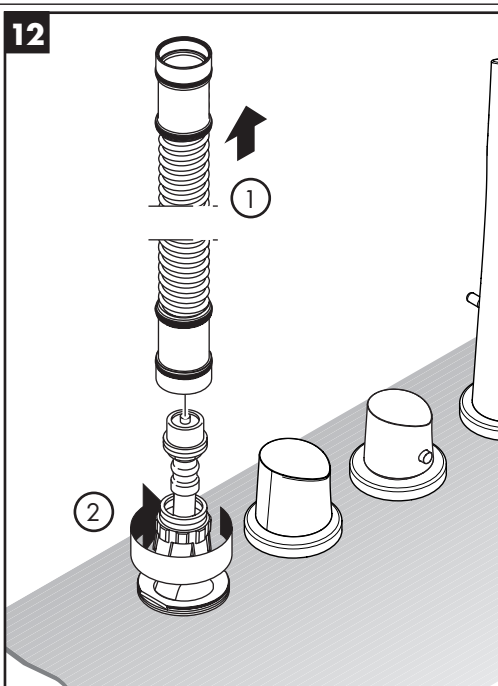

Español

Instale la varilla del distribuidor.

Apriete el tornillo del surtidor.

Tire la manguera Secuflex hacia afuera de la pieza interior.

Retire el protector de yeso.

Retire la manguera Secuflex hacia afuera de la pieza interior.

Desconecte la manguera Secuflex de la manguera de alta presión desenroscando la tuerca blanca de plástico.

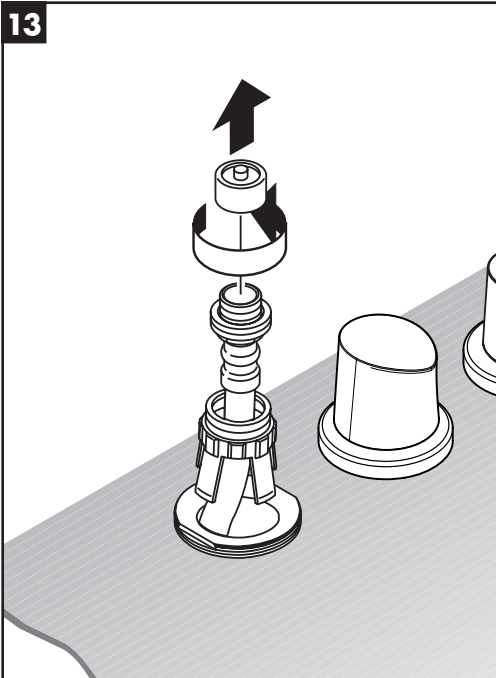

English

Remove the plug from the high pressure hose.

Install the check valve.

The arrow on the check valve indicates the direction of the water flow.

Français

Retirez le bouchon du tuyau à haute pression.

Installez le clapet anti-retour.

La flèche sur le clapet anti-retour indique le sens de l'écoulement de l'eau.

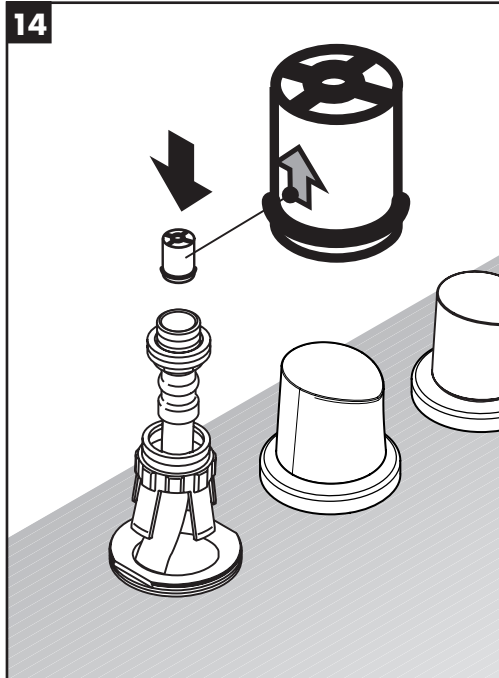

Español

Retire el tapón de la manguera de alta presión.

Instale la válvula de retención.

La flecha en la válvula de retención indica la dirección del caudal de agua.

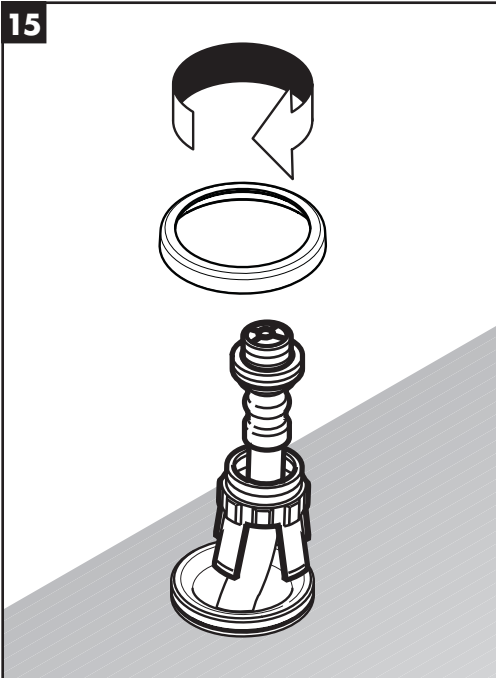

English

Install the handshower holder escutcheon.

Lubricate the handshower hose and the Secuflex hose using silicon spray and a dry, soft cloth.

Français

Installez l'écusson du support de douchette

Lubrifiez le tuyau de douchette et le tuyau Secuflex en utilisant un jet en silicone et un chiffon doux et sec.

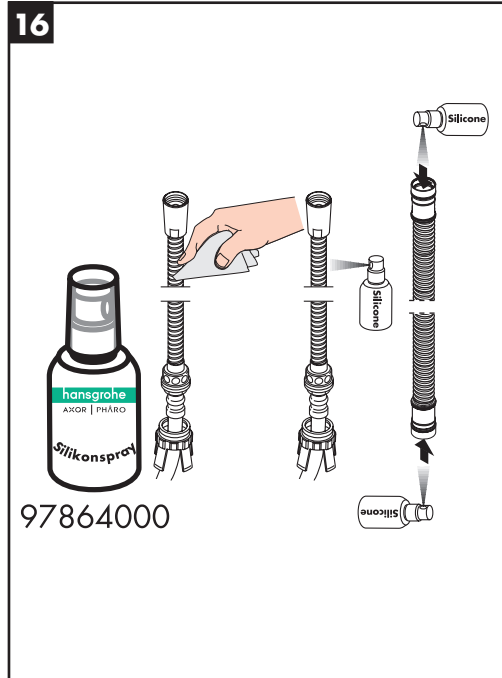

Español

Instale el escudo del soporte de ducha de mano.

Lubrique la manguera de la ducha de mano y la manguera Secuflex usando un rociador de silicona y un paño suave y seco.

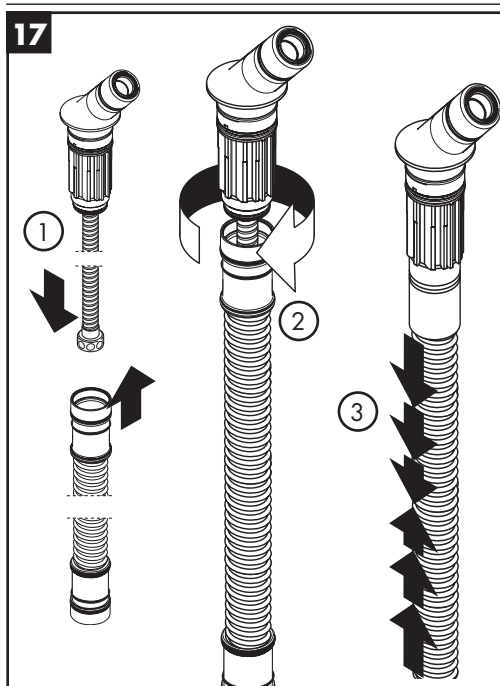

English

Feed the handshower hose down through the Secuflex hose.

Connect the Secuflex hose to the handshower holder.

Connect the handshower hose to the high pressure hose.

Tighten the plastic nut.

Français

Faites passer le tuyau de douche à travers le tuyau Secuflex.

Raccordez le tuyau Secuflex au support de douche.

Raccordez le tuyau de la douche au tuyau à haute pression.

Serrez l'écrou en plastique.

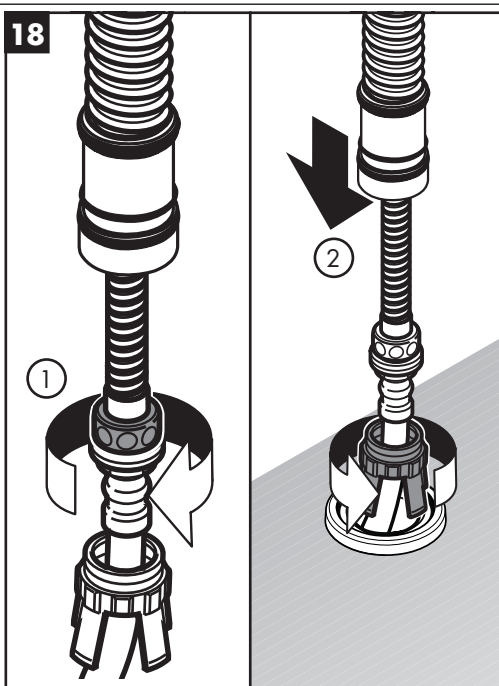

Español

Empuje la manguera de la ducha de mano hacia abajo por la manguera Secuflex.

Conecte la manguera Secuflex al soporte de ducha de mano.

Conecte la manguera de la ducha de mano a la manguera de alta presión.

Apriete la tuerca de plástico.

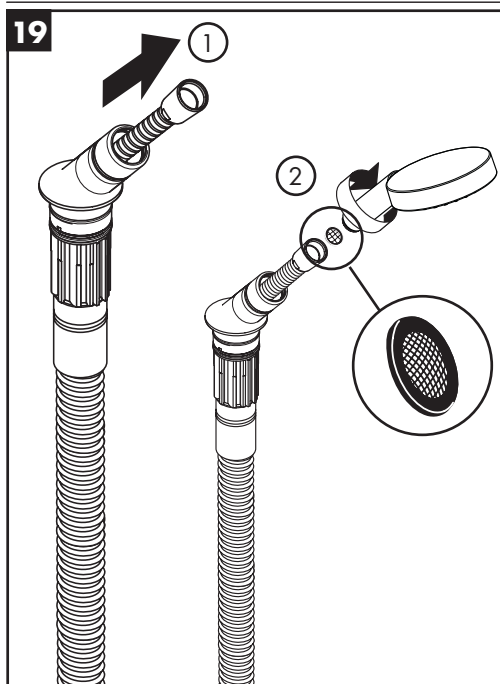

English

Connect the handshower to the handshower hose.

Cut the o-rings on the end of the Secuflex hose.

Lubricate the handshower holder using the Silicone spray.

Push the Secuflex hose down into the rough.

Français

Raccordez la douchette au tuyau de la douchette.

Coupez les joints toriques sur l'extrémité du tuyau Secuflex.

Lubrifiez le support de douchette à l'aide d'un jet en silicone.

Poussez le tuyau Secuflex dans la pièce intérieure.

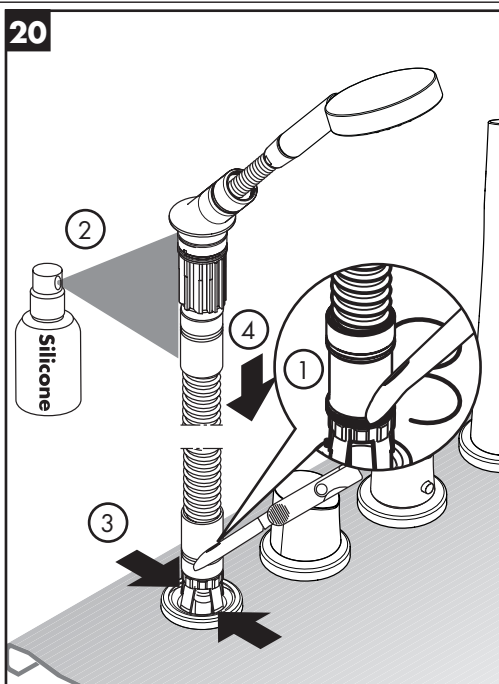

Español

Conecte la ducha de mano a la manguera.

Corte los retenes anulares del extremo de la manguera Secuflex.

Lubrique el soporte de ducha de mano utilizando un rociador de silicona.

Tire la manguera Secuflex hacia abajo de la pieza interior.

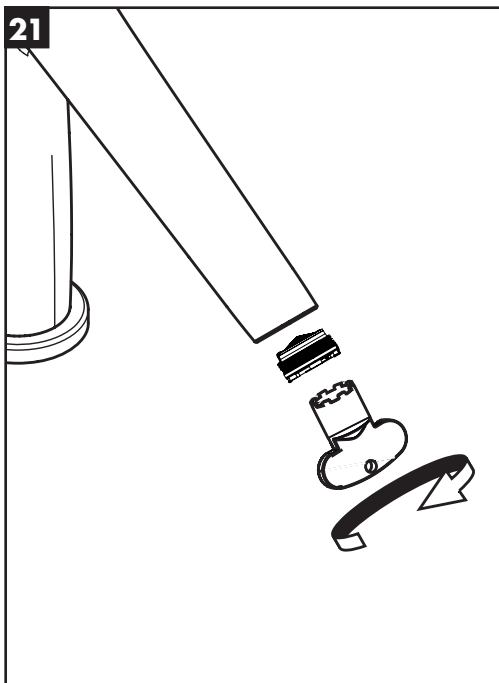

English

Remove the aerator from the spout.

Turn the water on. Allow the spout to flush for at least two minutes.

Français

Retirez l'aérateur du bec.

Ouvrez l'eau. Rincez le bec pendant au moins deux minutes.

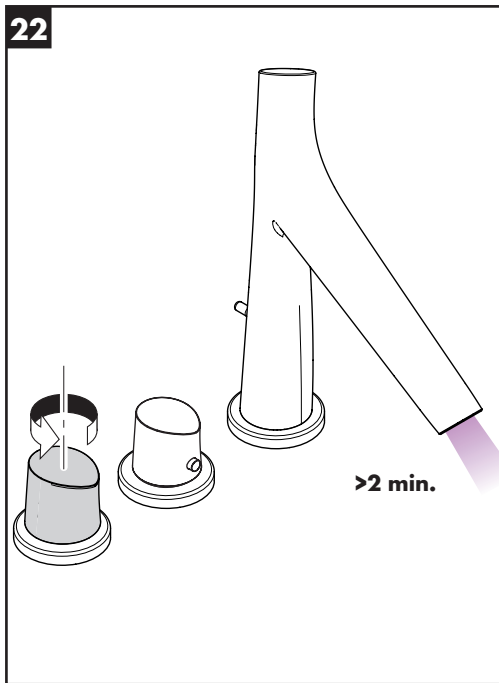

Español

Retire el aireador del orificio del surtidor.

Abra el suministro de agua. Deje que el surtidor se enjague durante dos minutos como mínimo.

23

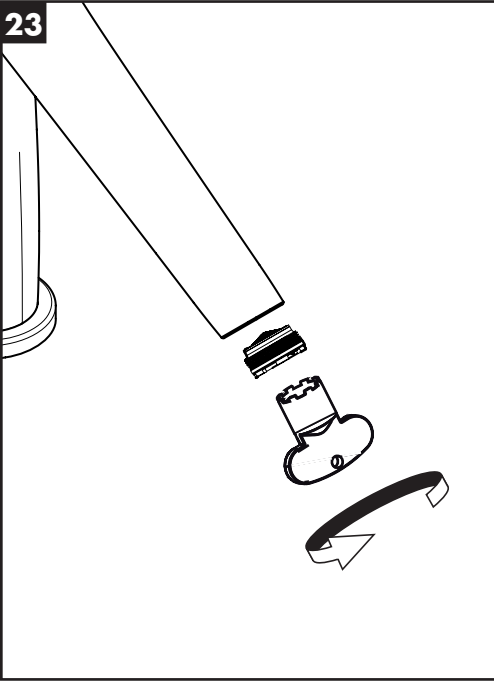

English

Install the aerator.

Français

Installez l'aérateur.

Español

Instale el aireador.

Set the high temperature limit stop / Réglez la butée limite d'eau chaude / Fije el tope de limite de alta temperatura

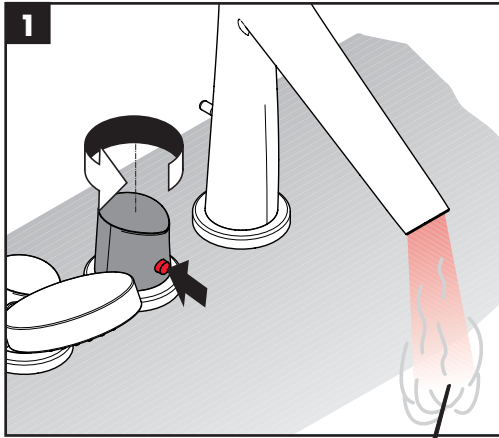

< 120° F* 



12

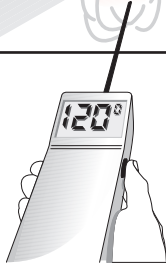

> 120° F 



2

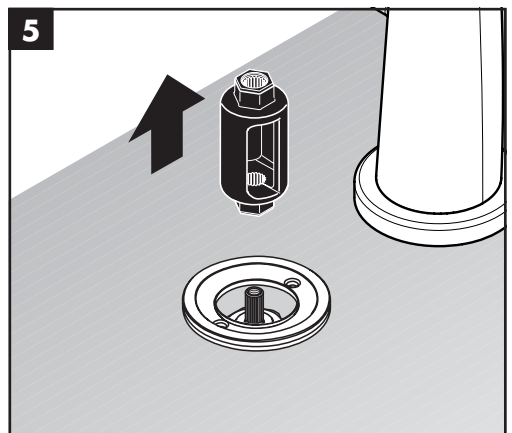
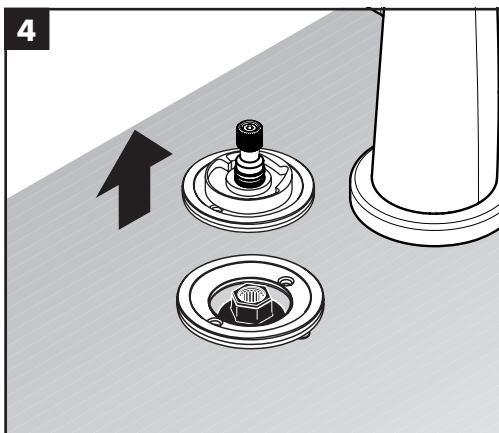
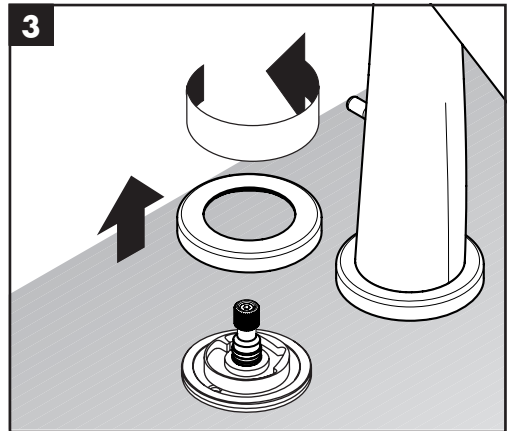
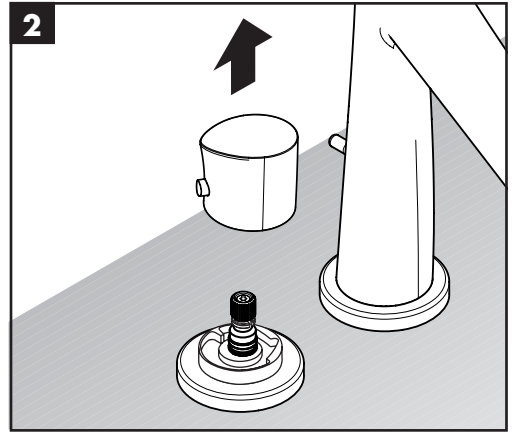

Set the high temperature limit stop / Réglez la butée limite d'eau chaude / Fije el tope de límite de alta temperatura

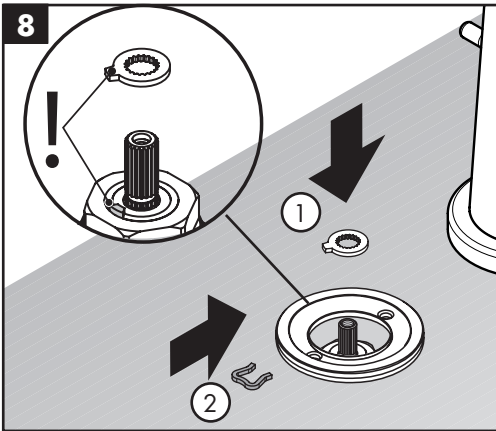
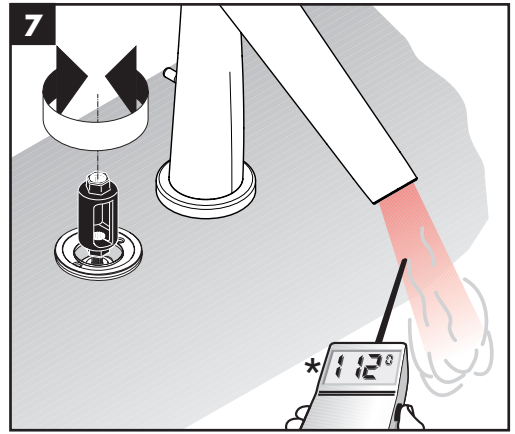
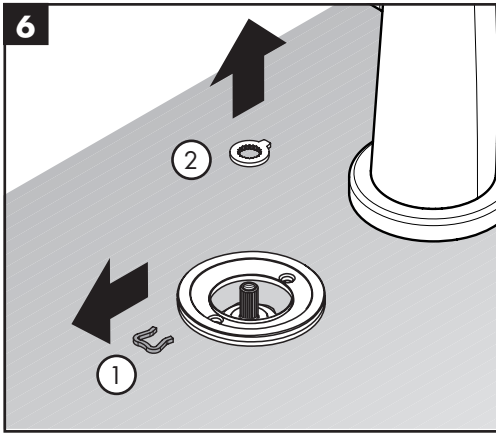

* Follow all applicable local plumbing codes regarding the maximum allowable high temperature.

* Suivez tous les locaux applicables les codes de plomberie concernant le maximum admissible haute température.

* Siga todos los códigos locales de plomería el límite máximo de temperatura alta.

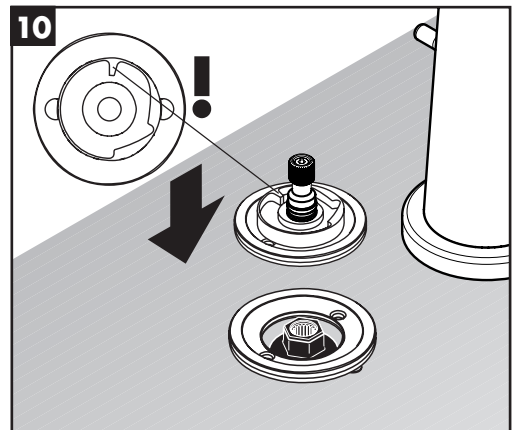
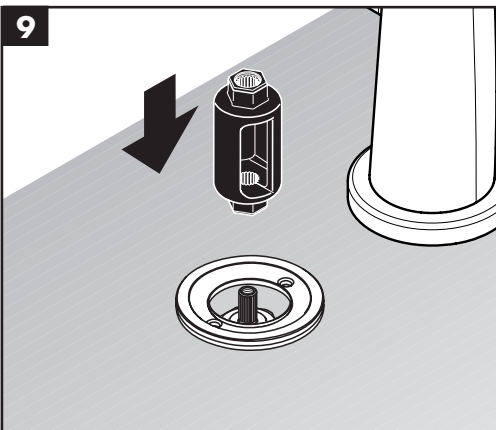

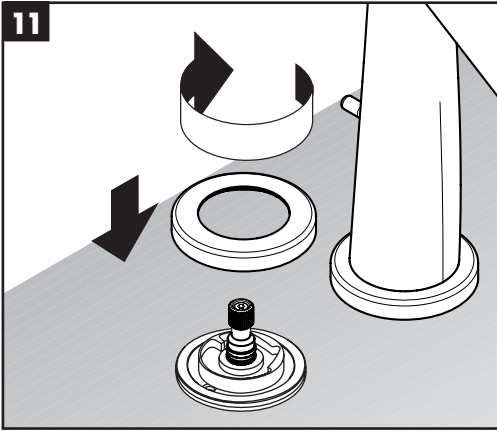

Justify the handle / Réglez la poignée / Ajuste el mando

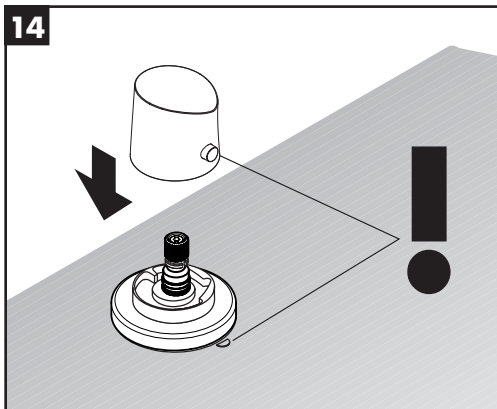
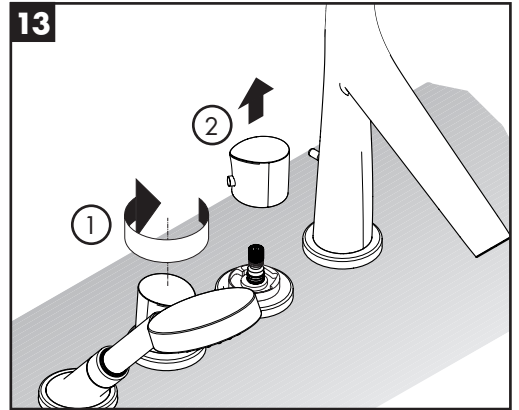
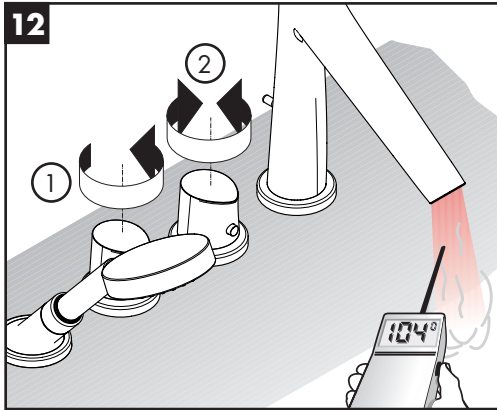

Replacement Parts / Pièces détachées / Repuestos

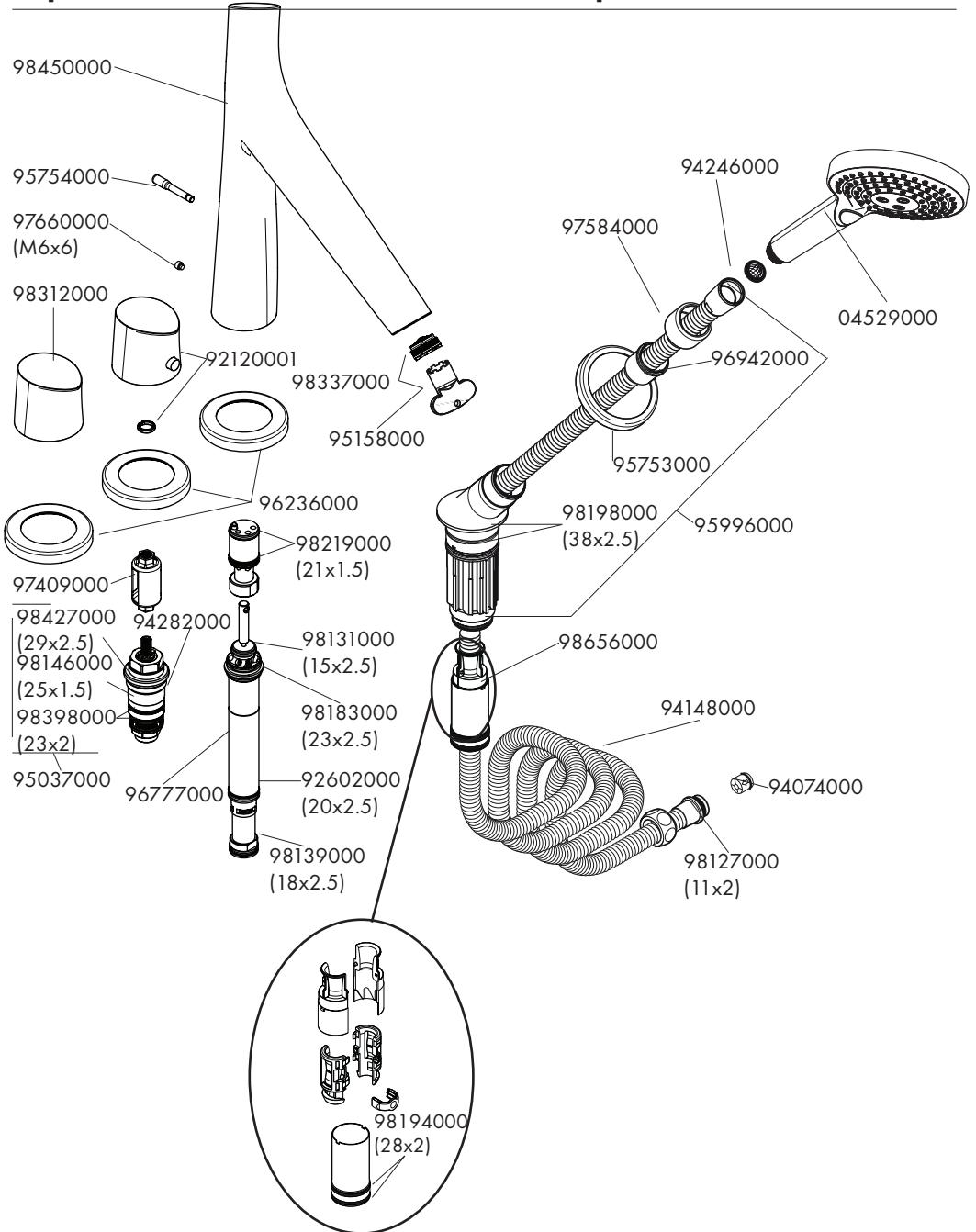

User Instructions / Instructions de service / Manejo

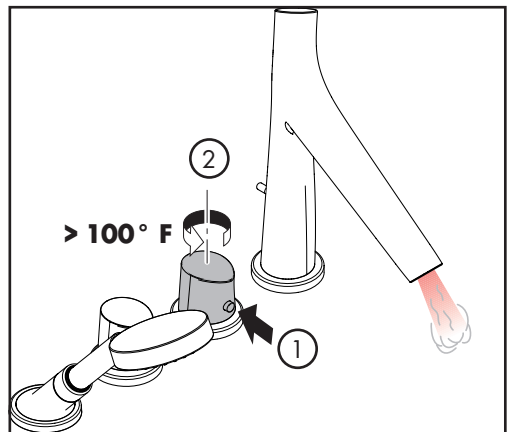
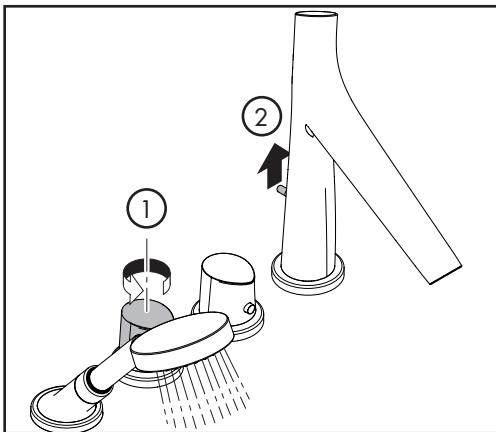
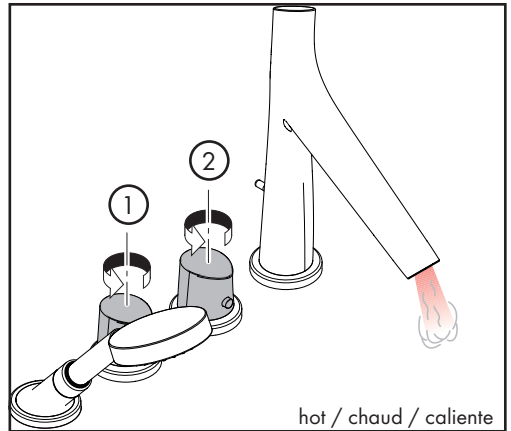
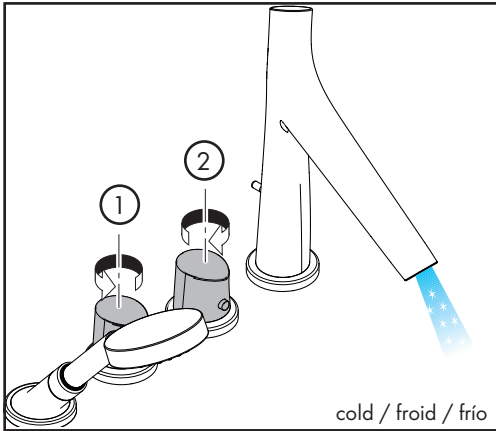
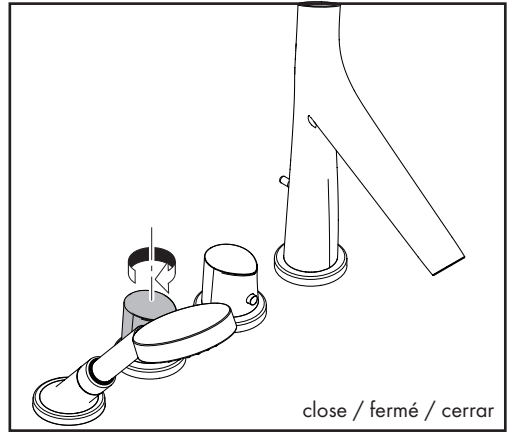
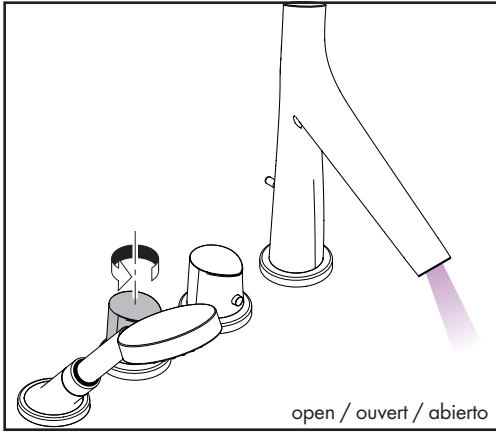

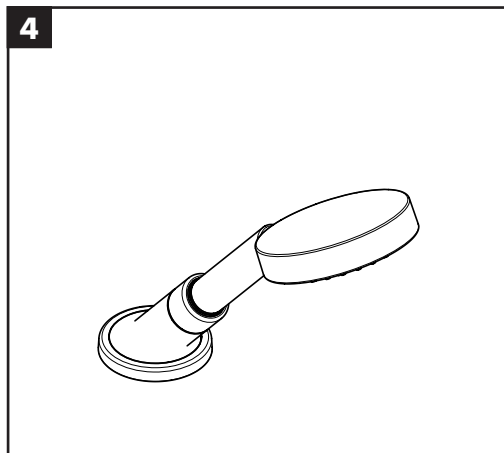
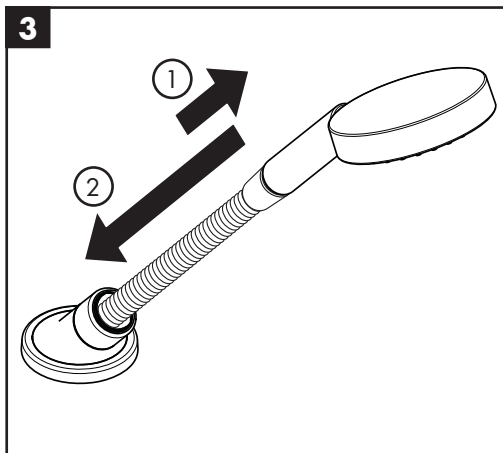
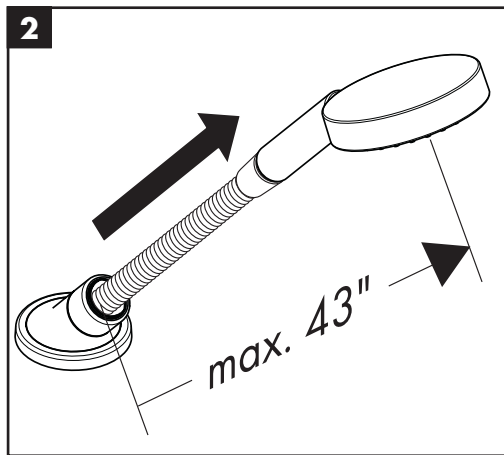
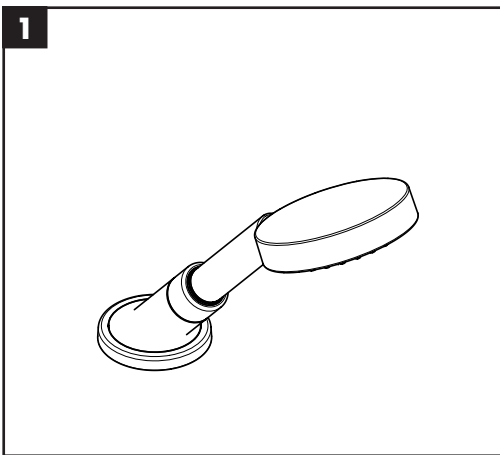

Cleaning / Nettoyage / Limpieza

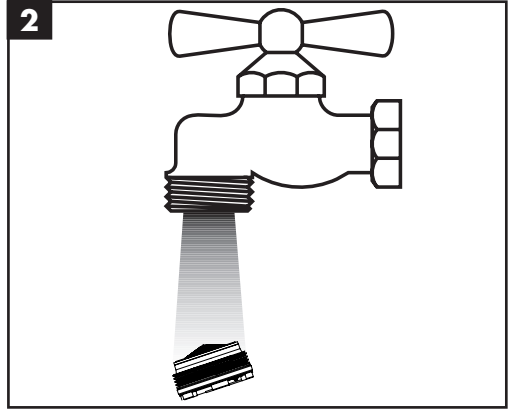
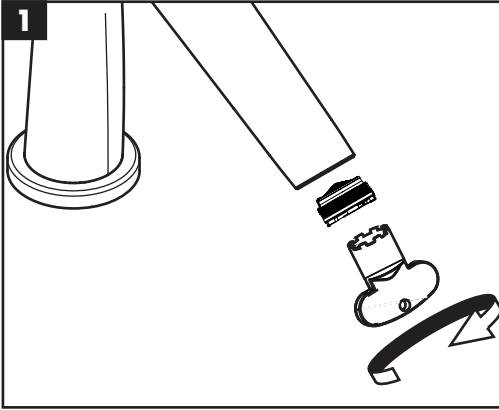

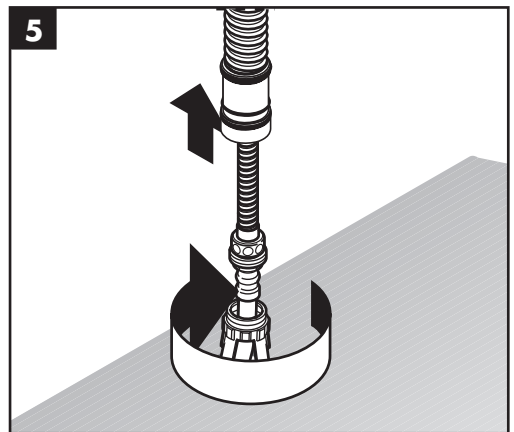
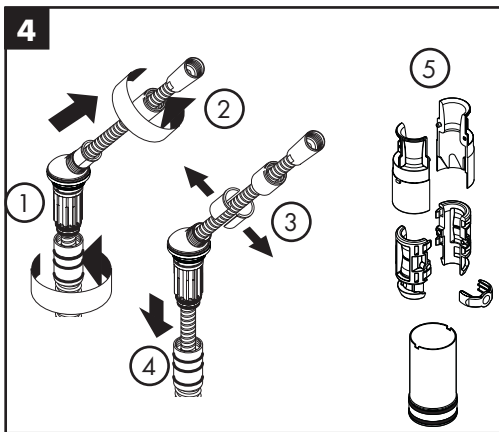
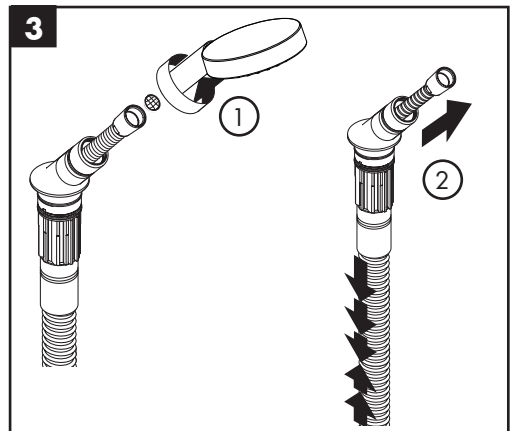
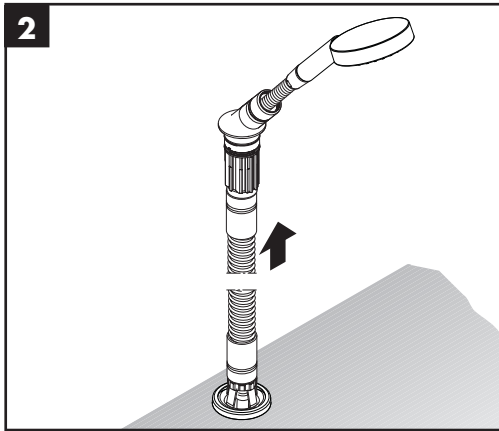
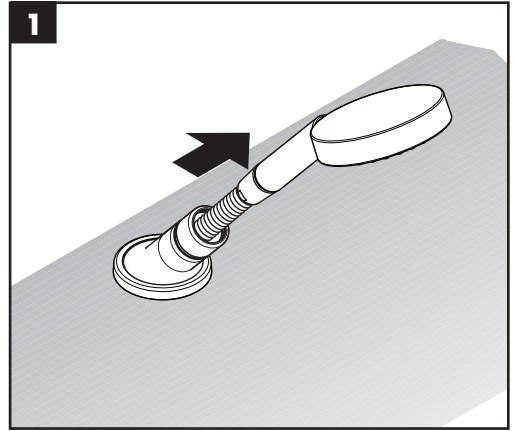
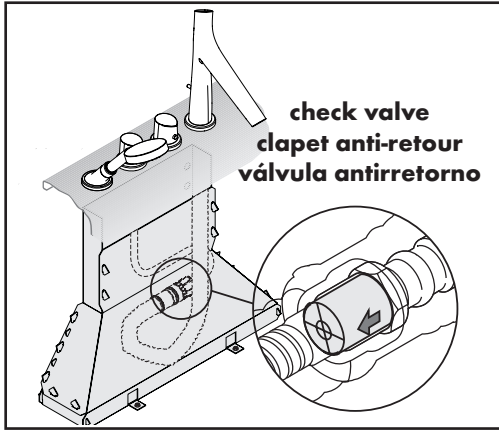

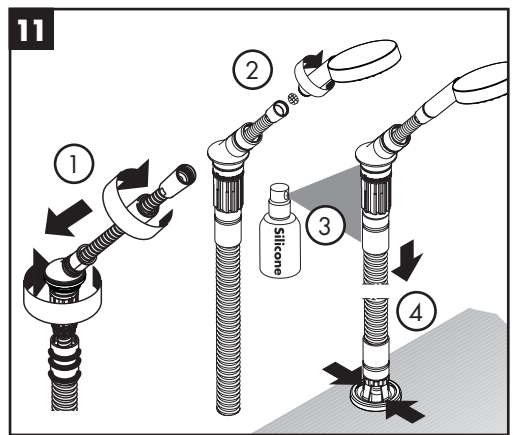
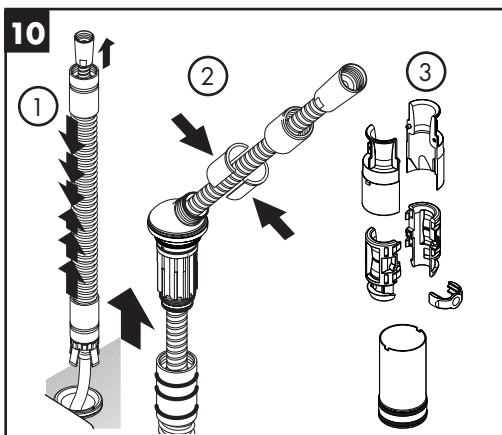
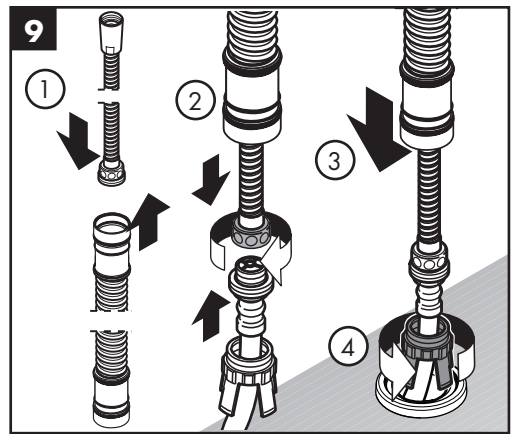
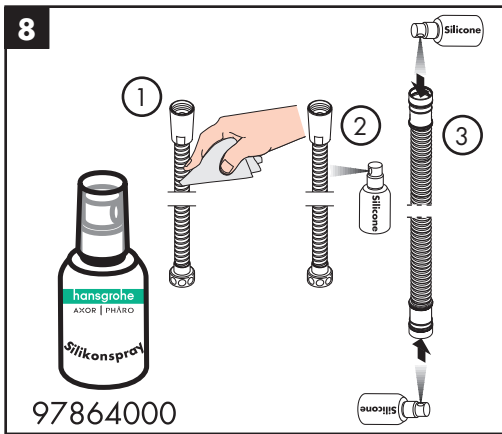
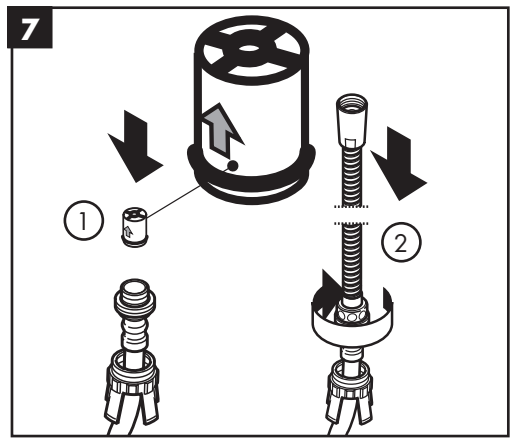
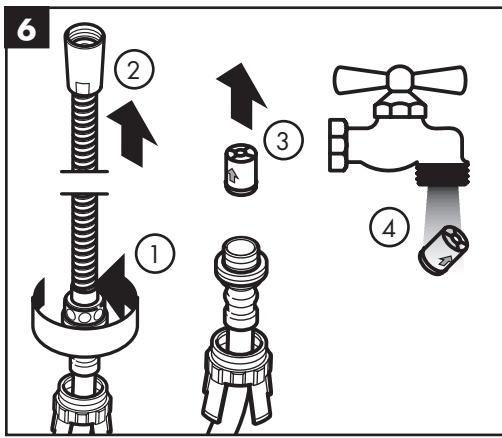

Cleaning Recommendation for Hansgrohe Products

Modern bathroom faucets, kitchen faucets and shower products are made from different materials to comply with the needs of the market with regard to design and functionality. To avoid damage to the product, it is necessary to take proper care of it.

For best results:

- Prevent the buildup of mineral scale and /or soap residue by cleaning your Hansgrohe product(s) when needed.
- Select a cleaning agent specifically intended for the type of product.
- **Do not** use these types of cleaners as they will cause damage to your Hansgrohe product:
 - ✘ Any cleaning agent containing hydrochloric acid, formic acid, lye, or acetic acid.
 - ✘ Abrasive cleaning powders, pads, or brushes.
 - ✘ Steam cleaners.
 - ✘ "No rinse" cleaning agents.
- **Always** follow the instructions provided by the manufacturer of the cleaning agent.
- **Do not** mix cleaning agents, unless directed by the manufacturer.
- **Do not** spray cleaners directly onto the product as drops could enter openings and gaps and cause damage. When using spray cleaners, spray the cleaner onto a soft cloth or sponge.
- **Always** rinse your Hansgrohe product thoroughly with clear water and polish dry with a soft cloth after cleaning.

Important

- Residue from soaps and shampoos can cause damage. Rinse the product with clean water after each use.
- Residue from basin/tub/tile cleaner can cause damage to faucets and fittings. Immediately rinse any overspray from the Hansgrohe product.
- **Damage to the product caused by improper care or the use of improper cleaning agents is not covered by the warranty.**
- **If a component of the product is damaged, replace it, as there is risk of injury.**

Conseil de nettoyage pour les produits Hansgrohe

Les robinets pour les salles de bains et les cuisines modernes ainsi que les produits récents pour les douches se composent de matériaux différents afin de satisfaire aux besoins du marché en termes de conception et de fonctionnalité. Afin d'éviter d'endommager le produit, il est nécessaire d'en prendre soin.

Pour de meilleurs résultats :

- Empêchez l'accumulation de tarte et/ou de résidu de savon en nettoyant votre produit Hansgrohe lorsque c'est nécessaire.
- Sélectionnez un produit de nettoyage spécifiquement prévu pour ce type de produit.
- **N'utilisez pas** ces types de nettoyants car ils peuvent endommager votre produit Hansgrohe :
 - ✘ Tout produit de nettoyage contenant de l'acide chlorhydrique, de l'acide formique, de la potasse ou de l'acide acétique.
 - ✘ Les poudres de nettoyage, les tampons ou les brosses abrasives.
 - ✘ Les nettoyeurs à vapeur.
 - ✘ Les produits de nettoyage « sans rinçage ».
- **Ne mélangez pas** les produits de nettoyage, à moins que cela soit indiqué par le fabricant.
- **Ne pulvérisez pas** les nettoyants directement sur le produit car des gouttes pourraient entrer dans les ouvertures et les fentes et causer des dommages. Lorsque vous utilisez des nettoyants par pulvérisation, pulvériser le nettoyant sur un chiffon ou une éponge douce.
- Après le nettoyage rincer abondamment à l'eau claire pour éliminer intégralement les restes de détergent.

Important

- Les résidus de produits pour le corps comme les savons liquides, shampoings, gels de douche, teintures pour cheveux, parfums, après-rasage et vernis à ongles peuvent causer des détériorations. Rincez le produit avec de l'eau propre après chaque utilisation.
- Le résidu provenant des nettoyeurs pour cuvette/baignoire/carrelage peut endommager les robinets et les raccords de tuyauterie. Rincez immédiatement toute surpulvérisation sur le produit Hansgrohe.
- De même, il est interdit de stocker des détergents ou des produits chimiques sous les produits, par ex. dans un meuble sous lavabo, car les vapeurs qui s'en dégagent risquent d'abîmer les produits.
- **Les dommages au produit causés par un mauvais entretien ou par l'utilisation de produits de nettoyage inadéquats ne sont pas couverts par la garantie.**
- **Si un composant du produit est endommagé, remplacez-le, car il existe un risque de blessure.**

Recomendación de limpieza para los productos de Hansgrohe

Hoy en día, las griferías de baño y de cocina así como duchas modernas se componen de materiales muy distintos para satisfacer las exigencias del mercado respecto al diseño y la funcionalidad. Para evitar daños y reclamaciones hay que tener en cuenta ciertos aspectos tanto en el uso como en su limpieza.

Para obtener mejores resultados:

- Evite la acumulación de restos de jabón o sarro limpiando el producto Hansgrohe cuando sea necesario.
- Seleccione un agente de limpieza diseñado específicamente para el tipo de producto.
- **No use** estos tipos de limpiadores, ya que causarán daño a su producto Hansgrohe:
 - ✗ Agentes limpiadores que contengan ácido clorhídrico, fórmico, acético o lejía.
 - ✗ Polvos, paños o cepillos de limpieza abrasivos.
 - ✗ Limpiadores a vapor
 - ✗ Agentes de limpieza "sin enjuague".
- **Siempre** siga las instrucciones provistas por el fabricante del agente de limpieza.
- **No mezcle** los agentes de limpieza, a menos que esté indicado por el fabricante.
- **No rocíe** limpiadores directamente sobre el producto, ya que podrían caer gotas sobre las aberturas y espacios y causar daños. Cuando use limpiadores en spray, rocíe el limpiador sobre un paño suave o esponja.
- **Siempre** enjuague su producto Hansgrohe con agua limpia y séquelo y lustrelo con un paño suave después de la limpieza.

Importante

- Los residuos de productos de aseo como jabón líquido, champú, gel de ducha, tintes de pelo, perfumes, lociones de afeitado y esmalte de uñas pueden dañar también los materiales. Enjuague el producto con agua limpia después de cada uso.
- Los residuos de limpiadores para lavatorios, bañeras o azulejos pueden causar daño a los grifos y accesorios. Enjuague inmediatamente cualquier derrame que haya sobre el producto de Hansgrohe.
- Tampoco pueden generarse depósitos de productos de limpieza o químicos debajo de los productos, p. ej. en un armario de lavabo. De lo contrario, los vapores generados pueden dañar los productos.
- **Los daños que resulten de un cuidado inadecuado o uso de agentes de limpieza inadecuados no están cubiertos por la garantía.**
- **Si se daña un componente del producto, reemplácelo, ya que existe riesgo de lesión.**

Limited Consumer Warranty

This product has been manufactured and tested to the highest quality standards by Hansgrohe, Inc. ("Hansgrohe"). This warranty is limited to Hansgrohe products that are purchased by a consumer in the United States or Canada after March 1, 1996, and installed in either in the United States or in Canada.

WHO IS COVERED BY THE WARRANTY

This warranty extends to the original purchaser only. This warranty is non-transferable.

WHAT IS COVERED BY THE WARRANTY

The warranty covers only your Hansgrohe manufactured product. Hansgrohe warrants this product against defects in material or workmanship as follows:

Hansgrohe will replace at no charge for parts only or, at its option, replace any product or part of the product that proves defective because of improper workmanship and/or material, under normal installation, use, service and maintenance. If Hansgrohe is unable to provide a replacement and repair is not practical or cannot be made in timely fashion, Hansgrohe may elect to refund the purchase price in exchange for the return of the product.

LENGTH OF WARRANTY

Replacement or repaired parts of products will be covered for the term of this warranty, as stated in the following two sentences. If you are a consumer who purchased the product for use primarily for personal, family or household purposes, this warranty extends for as long as you own the product and the home in which the product is originally installed. If you purchased the product for use primarily for any other purpose, including, without limitation, a commercial purpose, this warranty extends only (i) for 1 year, with respect to Hansgrohe & Commercial products, and (ii) for 5 years, with respect to Axor products.

THIS WARRANTY DOES NOT COVER, AND HANSGROHE WILL NOT PAY FOR:

- A. Conditions, malfunctions or damage not resulting from defects in material or workmanship.
- B. Conditions, malfunctions or damage resulting from (1) normal wear and tear, improper installation, improper maintenance, misuse, abuse, negligence, accident or alteration; (2) the use of abrasive or caustic cleaning agents or "no-rinse" cleaning products, or the use of the product in any manner contrary to the product instructions; or (3) conditions in the home such as excessive water pressure or corrosion.
- C. Labor and other expenses for disconnection, deinstallation, or return of the product for warranty service (including but not limited to proper packaging and shipping costs), or for installation or reinstallation of the product.
- D. Accessories, connected materials and products, or related products not manufactured by Hansgrohe.
- E. Any Hansgrohe or Axor product sold for display purposes.
- F. Rubbed Bronze finish is subject to a 3-year limited warranty. Chrome and all PVD finishes are covered by the limited lifetime warranty.
- G. Hansgrohe Water Filtration System is subject to a 1-year limited warranty. Warranty does not include replacement filters.

TO OBTAIN WARRANTY PARTS OR INFORMATION

Contact your Hansgrohe retailer, or contact Technical Service at:

Hansgrohe, Inc.
1492 Bluegrass Lakes Parkway
Alpharetta, GA 30004
Toll-free 800-334-0455

In requesting warranty service, you will need to provide:

1. The sales receipt or other evidence of the date and place of purchase.
2. A description of the problem.
3. Delivery of the product or the defective part, postage prepaid and carefully packed and insured, to:

Hansgrohe, Inc.
1492 Bluegrass Lakes Parkway
Alpharetta, GA 30004
Toll-free 800-334-0455

When warranty service is completed, any repaired or replacement product or part will be returned to you postage prepaid.

EXCLUSIONS AND LIMITATIONS

REPAIR OR REPLACEMENT (OR, IN LIMITED CIRCUMSTANCES, REFUND OF THE PURCHASE PRICE) AS PROVIDED UNDER THIS WARRANTY IS THE EXCLUSIVE REMEDY OF THE PURCHASER. HANSGROHE NEITHER ASSUMES NOR AUTHORIZES ANY PERSON TO CREATE FOR IT ANY OTHER OBLIGATION OR LIABILITY IN CONNECTION WITH THIS PRODUCT. HANSGROHE SHALL NOT BE LIABLE TO PURCHASER OR ANY OTHER PERSON FOR ANY INCIDENTAL, SPECIAL OR CONSEQUENTIAL DAMAGES, ARISING OUT OF BREACH OF THIS WARRANTY OR ANY IMPLIED WARRANTY (INCLUDING BUT NOT LIMITED TO ANY IMPLIED WARRANTY OF MERCHANTABILITY).

Some States do not allow the exclusion or limitation of incidental or consequential damages, so the above limitation or exclusion may not apply to you. This warranty gives you specific legal rights, and you may also have other rights that vary from state to state.

TO THE EXTENT PERMITTED BY LAW, ANY IMPLIED WARRANTIES OF MERCHANTABILITY AND FITNESS FOR A PARTICULAR PURPOSE, ARE LIMITED TO THE DURATION OF THE EXPRESS WARRANTY.

Some states do not allow limitations on how long an implied warranty may last, so the above limitations may not apply to you. You may be required by law to give us a reasonable opportunity to correct or cure any failure to comply before you can bring any action in court against us under the Magnuson-Moss Warranty Act.

PRODUCT INSTRUCTIONS AND QUESTIONS

Upon purchase or prior to installation, please carefully inspect your Hansgrohe product for any damage or visible defect. Prior to installing, always carefully study the enclosed instructions on the proper installation and the care and maintenance of this product. If you have questions at any time about the use, installation or performance of your Hansgrohe product, or this warranty, please write us or call us toll-free at 800-334-0455.

hansgrohe

Hansgrohe, Inc. • 1490 Bluegrass Lakes Parkway • Alpharetta, GA 30004
Tel. 800-334-0455 • Fax 770-889-1783

www.hansgrohe-usa.com