

AXOR

DE /	Gebrauchsanleitung / Montageanleitung	02
FR /	Mode d'emploi / Instructions de montage	03
EN /	Instructions for use / assembly instructions	04
IT /	Istruzioni per l'uso / Istruzioni per Installazione	05
ES /	Modo de empleo / Instrucciones de montaje	06
NL /	Gebruiksaanwijzing / Handleiding	07
DK /	Brugsanvisning / Monteringsvejledning	08
PT /	Instruções para uso / Manual de Instalação	09
PL /	Instrukcja obsługi / Instrukcja montażu	10
CS /	Návod k použití / Montážní návod	11
SK /	Návod na použitie / Montážny návod	12
ZH /	用户手册 / 组装说明	13
RU /	Руководство пользователя / Инструкция по монтажу	14
FI /	Käyttöohje / Asennusohje	15
SV /	Bruksanvisning / Monteringsanvisning	16
LT /	Vartotojo instrukcija / Montavimo instrukcijos	17
HR /	Upute za uporabu / Uputstva za instalaciju	18
TR /	Kullanım kılavuzu / Montaj kılavuzu	19
RO /	Manual de utilizare / Instrucțiuni de montare	20
EL /	Οδηγίες χρήσης / Οδηγία συναρμολόγησης	21
SL /	Navodilo za uporabo / Navodila za montažo	22
ET /	Kasutusjuhend / Paigaldusjuhend	23
LV /	Lietošanas pamācība / Montāžas instrukcija	24
SR /	Uputstvo za upotrebu / Uputstvo za montažu	25
NO /	Bruksanvisning / Montasjeveiledning	26
BG /	Инструкция за употреба / Ръководство за монтаж	27
SQ /	Udhëzuesi i përdorimit / Udhëzime rreth montimit	28
AR /	تعليمات التجميع / دليل الاستخدام	29
HU /	Használati útmutató / Szerelési útmutató	30
JP /	取扱説明書 / 施工説明書	31

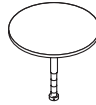

AXOR Exafill
58300XXX

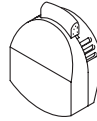
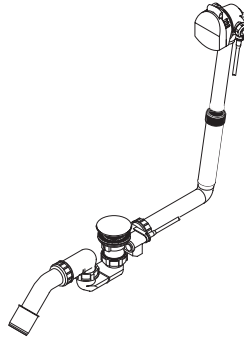

AXOR Exafill
58303XXX

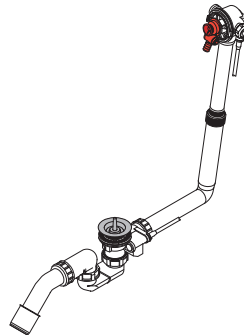

AXOR Exafill
58301180 / 58302180

INSTALLATION

⚠ SICHERHEITSHINWEISE

- ⚠ Bei der Montage müssen zur Vermeidung von Quetsch- und Schnittverletzungen Handschuhe getragen werden.
- ⚠ Das Produkt darf nicht als Haltegriff benutzt werden. Es muss ein separater Haltegriff montiert werden.

MONTAGEHINWEISE

- / Vor der Montage muss das Produkt auf Transportschäden untersucht werden. Nach dem Einbau werden keine Transport- oder Oberflächenschäden anerkannt.
- / Die Leitungen und die Armatur müssen nach den gültigen Normen montiert, gespült und geprüft werden.
- / Die in den Ländern jeweils gültigen Installationsrichtlinien sind einzuhalten.
- / Anschluss mit flexiblem Schlauch. Art. Nr. 58192000 (siehe Seite 34 Abb. A)

INSTALLATION NACH EN 1717

(siehe Seite 34 Abb. C)

- / Bei der Montage der iBox universal mit integrierter Sicherungskombination (HD) ist darauf zu achten, daß die Mitte der Armatur min. 280 mm über dem Wannrand liegt.

VERWENDEN DES PROBEEINLAUFS

(siehe Seite 34 Abb. D)

- / Probefüllen der Wanne.
- / Spülen der Leitungen
- / Druckprüfung der Leitung zwischen Mischer und Probeeinlauf
- / Der Restwasserstrahl bei der Druckprüfung ist beabsichtigt. Er soll an das Schließen des Mixers nach der Druckprüfung erinnern und Kreuzfluss am Mischer vermeiden.

TECHNISCHE DATEN

Ablaufleistung	53 l/min
Überlaufleistung	36 l/min

SYMBOLERKLÄRUNG



Kein essigsäurehaltiges Silikon verwenden!



MONTAGEBEISPIELE
(siehe Seite 40)



MASSE (siehe Seite 32)



DURCHFLUSSDIAGRAMM
(siehe Seite 32)



SERVICETEILE (siehe Seite 39)

XXX = Farbcodierung

000 = Chrom

020 = Polished Chrome

130 = Polished Bronze

140 = Brushed Bronze

250 = Brushed Gold-Optic

260 = Brushed Chrome

300 = Polished Redgold

310 = Brushed Redgold

330 = Polished Black Chrome

340 = Brushed Black Chrome

800 = Stainless Steel Optic

820 = Brushed Nickel

830 = Polished Nickel

930 = Polished Brass

950 = Brushed Brass

990 = Polished Gold-Optic



SONDERZUBEHÖR (siehe Seite 39)
(nicht im Lieferumfang enthalten)

- / Anschluss Schlauch Artikelnummer 58308000



REINIGUNG (siehe Seite 36)



PRÜFZEICHEN (siehe Seite 41)

△ CONSIGNES DE SÉCURITÉ

- △ Lors du montage, porter des gants de protection pour éviter toute blessure par écrasement ou coupure.
- △ Le produit ne doit pas servir de poignée. Monter pour cela une poignée séparée.

INSTRUCTIONS POUR LE MONTAGE

- / Avant son montage, s'assurer que le produit n'a subi aucun dommage pendant le transport. Après le montage, tout dommage de transport ou de surface ne pourra pas être reconnu.
- / Les conduites et la robinetterie doivent être montés, rincés et contrôlés selon les normes en vigueur.
- / Les directives d'installation en vigueur dans le pays concerné doivent être respectées.
- / Raccord avec flexible réf. 58192000 (voir pages 34 Fig. A)

INSTALLATION SELON EN 1717

(voir pages 34 Fig. C)

- / Lors du montage de iBox universal avec combinaison de sécurité (HP), veiller à ce que l'axe de la robinetterie se trouve au moins à 280 mm au-dessus du bord de la baignoire

UTILISER L'ENTRÉE D'ESSAI

(voir pages 34 Fig. D)

- / Tester la baignoire en la remplissant
- / Rincer les conduites
- / Contrôle de la pression de conduite entre mélangeur et entrée
- / Le jet de l'eau restante pendant le contrôle sous pression est prévu. Il doit rappeler la fermeture du mitigeur après le contrôle sous pression et éviter l'inversion du raccordement du mitigeur.

INFORMATIONS TECHNIQUES

Débit d'écoulement	53 l/min
capacité d'évacuation	36 l/min

DESCRIPTION DU SYMBOLE



Ne pas utiliser de silicone contenant de l'acide acétique!



EXEMPLES DE MONTAGE
(voir pages 40)



DIMENSIONS (voir pages 32)



DIAGRAMME DU DÉBIT
(voir pages 32)



PIÈCES DÉTACHÉES (voir pages 39)

XXX = Couleurs
 000 = Chromé
 020 = Polished Chrome
 130 = Polished Bronze
 140 = Brushed Bronze
 250 = Brushed Gold-Optic
 260 = Brushed Chrome
 300 = Polished Redgold
 310 = Brushed Redgold
 330 = Polished Black Chrome
 340 = Brushed Black Chrome
 800 = Stainless Steel Optic
 820 = Brushed Nickel
 830 = Polished Nickel
 930 = Polished Brass
 950 = Brushed Brass
 990 = Polished Gold-Optic



ACCESSOIRES EN OPTION
(voir pages 39)
(ne fait pas partie de la fourniture)

- / flexible de raccordements référence 58308000



NETTOYAGE (voir pages 36)



CLASSIFICATION ACOUSTIQUE
ET DÉBIT (voir pages 41)

⚠ SAFETY NOTES

- ⚠ Gloves should be worn during installation to prevent crushing and cutting injuries.
- ⚠ The product may not be used as a holding handle. A separate handle must be installed.

INSTALLATION INSTRUCTIONS

- / Prior to installation, inspect the product for transport damages. After it has been installed, no transport or surface damage will be honoured.
- / The pipes and the fixture must be installed, flushed and tested as per the applicable standards.
- / The plumbing codes applicable in the respective countries must be observed.
- / Connection with flexible hose code nr. 58192000. (see page 34 Fig. A)

INSTALLATION TO EN 1717

(see page 34 Fig. C)

- / When assembling the iBox universal with integrated safety combination (HD) pay attention that the middle of the mixer is min. 280 mm above the upper edge of the bath tub.

USE OF THE FLUSH PLUG

(see page 34 Fig. D)

- / Testfilling of the bath tub.
- / Flushing of the pipes.
- / Pressure test of the pipes between mixer and flush plug
- / The residual water jet during pressure test is taken into account. It shall remind you of closing the mixer after the pressure test and avoid cross flow at the mixer.

TECHNICAL DATA

Sequence power	53 l/min
overflow capacity	36 l/min

SYMBOL DESCRIPTION



Do not use silicone containing acetic acid!



INSTALLATION EXAMPLE
(see page 40)



DIMENSIONS (see page 32)



FLOW DIAGRAM (see page 32)



SPARE PARTS (see page 39)

XXX = Colors

000 = Chrome Plated

020 = Polished Chrome

130 = Polished Bronze

140 = Brushed Bronze

250 = Brushed Gold-Optic

260 = Brushed Chrome

300 = Polished Redgold

310 = Brushed Redgold

330 = Polished Black Chrome

340 = Brushed Black Chrome

800 = Stainless Steel Optic

820 = Brushed Nickel

830 = Polished Nickel

930 = Polished Brass

950 = Brushed Brass

990 = Polished Gold-Optic



SPECIAL ACCESSORIES
(see page 39) (order as an extra)

- / connection hose article number 58308000



CLEANING (see page 36)



TEST CERTIFICATE (see page 41)

△ INDICAZIONI SULLA SICUREZZA

- △ Durante il montaggio, per evitare ferite da schiacciamento e da taglio bisogna indossare guanti protettivi.
- △ Il prodotto non deve essere utilizzato come maniglia, questa deve essere montata separatamente.

ISTRUZIONI PER IL MONTAGGIO

- / Prima del montaggio è necessario controllare che non ci siano stati danni durante il trasporto. Una volta eseguito il montaggio, non verranno riconosciuti eventuali danni di trasporto o delle superfici.
- / Montare, lavare e controllare tubature e rubinetteria rispettando le norme correnti.
- / Vanno rispettate le direttive di installazione nazionali vigenti nel rispettivo paese.
- / Collegamento con raccordo flessibile cod. 58192000. (vedi pagg. 34 Fig. A)

INSTALLAZIONE SECONDO LA NORMA EN 1717 (vedi pagg. 34 Fig. C)

- / Quando si installa l'Ibox Universal con gli arresti di sicurezza (HD) integrati, occorre fare attenzione che il centro del valvolame sia almeno 280 mm circa sopra il bordo della vasca.

USO COLONNA DI SCARICO (vedi pagg. 34 Fig. D)

- / Riempire la vasca
- / Far scorrere l'acqua nel tubo
- / Testare la pressione del troppopieno tra il gruppo vasca incasso e la colonna di scarico
- / Il getto di acqua residua alla prova di pressione è fatto di proposito. Esso deve ricordare di chiudere il miscelatore dopo la prova di pressione ed evitare un flusso incrociato dal miscelatore.

DATI TECNICI

Portata di scarico	53 l/min
capacità del troppopieno	36 l/min

DESCRIZIONE SIMBOLO



Non utilizzare silicone contenente acido acetico!



ESEMPIO DI INSTALLAZIONE (vedi pagg. 40)



INGOMBRI (vedi pagg. 32)



DIAGRAMMA FLUSSO (vedi pagg. 32)



PARTI DI RICAMBIO (vedi pagg. 39)

XXX = Trattamento
 000 = Cromato
 020 = Polished Chrome
 130 = Polished Bronze
 140 = Brushed Bronze
 250 = Brushed Gold-Optic
 260 = Brushed Chrome
 300 = Polished Redgold
 310 = Brushed Redgold
 330 = Polished Black Chrome
 340 = Brushed Black Chrome
 800 = Stainless Steel Optic
 820 = Brushed Nickel
 830 = Polished Nickel
 930 = Polished Brass
 950 = Brushed Brass
 990 = Polished Gold-Optic



ACCESSORI SPECIALI (vedi pagg. 39)
 (non contenuto nel volume di fornitura)

- / raccordo flessibile codice articolo 58308000



PULITURA (vedi pagg. 36)



SEGNO DI VERIFICA (vedi pagg. 41)



△ INDICACIONES DE SEGURIDAD

- △ Durante el montaje deben utilizarse guantes para evitar heridas por aplastamiento o corte.
- △ El producto no debe ser utilizado como un elemento de sujeción. Debe montarse un elemento de sujeción separado.

INDICACIONES PARA EL MONTAJE

- / Antes del montaje se debe examinar el producto contra daños de transporte. Después de la instalación no se reconoce ningún daño de transporte o de superficie.
- / Los conductos y la grifería deben montarse, lavarse y comprobarse según las normas vigentes.
- / Es obligatorio el cumplimiento de las directrices de instalación vigentes en el país respectivo.
- / Conexión con manguera ref. 58192000 (ver página 34 Fig. A)

INSTALACIÓN SEGÚN DIN 1717

(ver página 34 Fig. C)

- / Montando la iBox universal con combinación de seguridad integrada (HD), procure que el centro de la grifería se encuentre al menos 280 mm encima del borde de la bañera.

UTILIZAR LA VÁLVULA DE PRUEBA

(ver página 34 Fig. D)

- / Llenar la bañera de prueba
- / Limpiar lavando los conductos
- / Prueba de presión en conducto entre el mezclador y la válvula de prueba
- / El chorro de agua residual durante la prueba de presión tiene un objetivo. Es para recordar que debe cerrarse el mezclador después del ensayo de presión y evitar un flujo cruzado en el mezclador.

DATOS TÉCNICOS

Capacidad de desagüe	53 l/min
capacidad de rebose	36 l/min

DESCRIPCIÓN DE SÍMBOLOS



No utilizar silicona que contiene ácido acético!



EJEMPLOS DE MONTAJE
(ver página 40)



DIMENSIONES (ver página 32)



DIAGRAMA DE CIRCULACIÓN
(ver página 32)



REPUESTOS (ver página 39)

XXX = Acabados
 000 = Cromado
 020 = Polished Chrome
 130 = Polished Bronze
 140 = Brushed Bronze
 250 = Brushed Gold-Optic
 260 = Brushed Chrome
 300 = Polished Redgold
 310 = Brushed Redgold
 330 = Polished Black Chrome
 340 = Brushed Black Chrome
 800 = Stainless Steel Optic
 820 = Brushed Nickel
 830 = Polished Nickel
 930 = Polished Brass
 950 = Brushed Brass
 990 = Polished Gold-Optic



OPCIONAL (ver página 39)
(no incluido en el suministro)

- / Conexión flexible artículo número 58308000



LIMPIAR (ver página 36)



MARCA DE VERIFICACIÓN
(ver página 41)

△ VEILIGHEID SINSTRUCTIES

- △ Bij de montage moeten ter voorkoming van knel- en snijwonden handschoenen worden gedragen.
- △ Het product mag niet als handgreep worden gebruikt. Er moet een aparte handgreep gemonteerd worden.

MONTAGE-INSTRUCTIES

- / Vóór de montage moet het product gecontroleerd worden op transportschade. Na de inbouw wordt geen transport- of oppervlakteschade meer aanvaard.
- / De leidingen en armaturen moeten gemonteerd, gespoeld en gecontroleerd worden volgens de geldige normen.
- / De in de overeenkomstige landen geldende installatierichtlijnen moeten nageleefd worden.
- / Aansluiting met flexibele aansluitslang best.nr. 58192000 (zie blz. 34 Afb. A)

INSTALLATIE NAAR EN 1717

(zie blz. 34 Afb. C)

- / Bij de montage van de iBox universal met geïntegreerde zekerheidscombinatie moet men erop letten, dat de kraan minimaal 280mm boven de badrand wordt geplaatst.

GEbruik VAN DE TESTUITLOOP

(zie blz. 34 Afb. D)

- / Testvullen van de badkuip
- / Doorspoelen van de leidingen
- / Testen van de leidingdruk tussen de kraan en de testuitloop
- / De restwaterstraal bij de drukcontrole is bedoeld. Hij moet u eraan herinneren de mengkraan na de drukcontrole dicht te draaien en kruisstroom aan de mengkraan vermijden.

TECHNISCHE GEGEVENS

Afvoercapaciteit	53 l/min
overloopcapaciteit	36 l/min

SYMBOLBESCHRIJVING



Gebruik geen zuurhoudende siliconen!



MONTAGEVOORBEELDEN
(zie blz. 40)



MATEN (zie blz. 32)



DOORSTROOMDIAGRAM
(zie blz. 32)



SERVICE ONDERDELEN
(zie blz. 39)

XXX = Kleuren

000 = Verchroomd

020 = Polished Chrome

130 = Polished Bronze

140 = Brushed Bronze

250 = Brushed Gold-Optic

260 = Brushed Chrome

300 = Polished Redgold

310 = Brushed Redgold

330 = Polished Black Chrome

340 = Brushed Black Chrome

800 = Stainless Steel Optic

820 = Brushed Nickel

830 = Polished Nickel

930 = Polished Brass

950 = Brushed Brass

990 = Polished Gold-Optic



TOEBEHOREN (zie blz. 39)
(behoort niet tot het leveringspakket)

- / aansluitslang Artikelnummer 58308000



REINIGEN (zie blz. 36)



KEURMERK (zie blz. 41)

⚠ SIKKERHEDSANVISNINGER

- ⚠ Ved monteringen skal der bruges handsker for at undgå kvæstelser og snitsår.
- ⚠ Produktet må ikke bruges som håndtag. Der skal monteres et separat håndtag.

MONTERINGSANVISNINGER

- / Før monteringen skal produktet kontrolleres for transportskader. Efter monteringen godkendes transportskader eller skader på overfladen ikke længere.
- / Ledningerne og armaturerne skal monteres, skylles og kontrolleres iht. de gældende standarder.
- / Installationsbestemmelserne, der gælder i det enkelte land, skal overholdes.
- / Tilslutning med fleksibel slange, art. Nr. 58192000 (se s. 34 Fig. A)

INSTALLATION EFTER EN 1717

(se s. 34 Fig. C)

- / Ved montering af iBox universal med integreret sikringskombination (HD) skal der tages hensyn til, at armaturens midte ligger min. 280 mm over karrets kant.

BRUG AF TESTINDLØBET (se s. 34 Fig. D)

- / Opfyldning (test) af karret.
- / Skylning af ledninger
- / Trykkontrol af ledning mellem blander og prøveindtag
- / Restvandstrålen ved trykafprøvning er tilsigtet. Den skal minde om at lukke blanderen efter trykafprøvningen og forhindre en tværsstrømning ved blanderen.

TEKNISKE DATA

Afløbskapacitet

53 l/min

overløbskapaciteten

36 l/min

SYMBOLBESKRIVELSE



Der må ikke benyttes eddikesyreholdig silikone!



MONTERINGSEKSEMPLER
(se s. 40)



MÅLENE (se s. 32)



GENNEMSTRØMNINGSDIAGRAM
(se s. 32)



RESERVEDELE (se s. 39)

XXX = Overflade

000 = Krom

020 = Polished Chrome

130 = Polished Bronze

140 = Brushed Bronze

250 = Brushed Gold-Optic

260 = Brushed Chrome

300 = Polished Redgold

310 = Brushed Redgold

330 = Polished Black Chrome

340 = Brushed Black Chrome

800 = Stainless Steel Optic

820 = Brushed Nickel

830 = Polished Nickel

930 = Polished Brass

950 = Brushed Brass

990 = Polished Gold-Optic



SPECIALTILBEHØR (se s. 39)
(ikke med i leveringsomfang)

- / Tilslutningsslange art. nr. 58308000



RENGØRING (se s. 36)



GODKENDELSE (se s. 41)



⚠ AVISOS DE SEGURANÇA

- ⚠ Durante a montagem devem ser utilizadas luvas de protecção, de modo a evitar ferimentos resultantes de entalamentos e de cortes.
- ⚠ O produto não pode ser utilizado como pega de apoio. Tem que ser montada uma pega separada.

AVISOS DE MONTAGEM

- / Antes da montagem deve-se controlar o produto relativamente a danos de transporte. Após a montagem não são aceites quaisquer danos de transporte ou de superfície.
- / As tubagens e a torneira têm que ser montadas, enxaguadas e verificadas de acordo com as normas em vigor.
- / A prescrições de instalação válidas nos respetivos países devem ser respeitadas.
- / Conexão com tubo flexível. Referência 58192000 (ver página 34 Fig. A)

INSTALAÇÃO SEGUNDO EN 1717 (ver página 34 Fig. C)

- / Durante a montagem da iBox universal com combinação de segurança integrada (HD) deve ter-se em atenção que o centro da misturadora se situe pelo menos, 280 mm acima do topo da banheira.

UTILIZAÇÃO DE UMA ENTRADA DE ENSAIO (ver página 34 Fig. D)

- / Enchimento de teste da banheira.
- / Lavagem das tubagens
- / Controlo de pressão da tubagem entre a misturadora e a entrada de teste
- / O jacto da água residual durante o teste de pressão é intencional. Este deve lembrar o encerramento do misturador após o teste de pressão e evitar um fluxo cruzado no misturador.

DADOS TÉCNICOS

Capacidade de escoamento	53 l/min
capacidade de escoamento	36 l/min

DESCRIÇÃO DO SÍMBOLO



Não utilizar silicone que contenha ácido acético!



EXEMPLOS DE MONTAGEM (ver página 40)



MEDIDAS (ver página 32)



FLUXOGRAMA (ver página 32)



PEÇAS DE SUBSTITUIÇÃO (ver página 39)

XXX = Acabamentos
 000 = Cromado
 020 = Polished Chrome
 130 = Polished Bronze
 140 = Brushed Bronze
 250 = Brushed Gold-Optic
 260 = Brushed Chrome
 300 = Polished Redgold
 310 = Brushed Redgold
 330 = Polished Black Chrome
 340 = Brushed Black Chrome
 800 = Stainless Steel Optic
 820 = Brushed Nickel
 830 = Polished Nickel
 930 = Polished Brass
 950 = Brushed Brass
 990 = Polished Gold-Optic



ACESSÓRIOS ESPECIAIS (ver página 39)
 (não incluído no volume de fornecimento)



/ Tubo flexível referência 58308000



LIMPEZA (ver página 36)



MARCA DE CONTROLO (ver página 41)

⚠ WSKAZÓWKI BEZPIECZEŃSTWA

- ⚠ Aby uniknąć zranień na skutek zgniecenia lub przecięcia, podczas montażu należy nosić rękawice ochronne.
- ⚠ Produktu nie wolno używać jako uchwytu do trzymania się. Należy zamontować osobny uchwyt.

WSKAZÓWKI MONTAŻOWE

- / Przed montażem należy skontrolować produkt pod kątem szkód transportowych. Po montażu nie widać żadnych szkód transportowych ani szkód na powierzchni.
- / Przewody i armatura muszą być montowane, płukane i kontrolowane według obowiązujących norm.
- / Należy przestrzegać wytycznych instalacyjnych obowiązujących w danym kraju.
- / Przyłącze z elastycznym węzłem. Nr art. 58192000 (patrz strona 34 Rys. A)

INSTALACJA ZGODNIE Z EN 1717

(patrz strona 34 Rys. C)

- / Przy montażu iBox universal z wbudowaną kombinacją zabezpieczającą (HD) należy zwrócić uwagę na to, by środek armatury znajdował się min. 280 mm ponad krawędzią wanny.

UŻYWANIE WŁOTU PRÓBNEGO

(patrz strona 34 Rys. D)

- / Próbne napełnienie wanny.
- / Płukanie przewodów
- / Kontrola ciśnienia w przewodzie między mieszaczem a wlotem próbnym
- / Resztkowy strumień wody przy kontroli ciśnienia jest zaplanowany. Ma ona przypomnieć o zamknięciu mieszalnika po kontroli ciśnienia i zapobiec przepływowi krzyżowemu w mieszalniku.

DANE TECHNICZNE

Wydajność odpływu	53 l/min
wydajność przelewu	36 l/min

OPIS SYMBOLU



Nie stosować silikonów zawierających kwas octowy!



PRZYKŁADY MONTAŻOWE
(patrz strona 40)



WYMIARY (patrz strona 32)



SCHEMAT PRZEPŁYWU
(patrz strona 32)



CZĘŚCI SERWISOWE
(patrz strona 39)

XXX = Kody kolorów

000 = Chrom

020 = Polished Chrome

130 = Polished Bronze

140 = Brushed Bronze

250 = Brushed Gold-Optic

260 = Brushed Chrome

300 = Polished Redgold

310 = Brushed Redgold

330 = Polished Black Chrome

340 = Brushed Black Chrome

800 = Stainless Steel Optic

820 = Brushed Nickel

830 = Polished Nickel

930 = Polished Brass

950 = Brushed Brass

990 = Polished Gold-Optic



WYPOSAŻENIE SPECJALNE
(patrz strona 39) (Nie jest częścią dostawy)

- / Wąż przyłączeniowy nr art. 58308000



CZYSZCZENIE (patrz strona 36)



ZNAK JAKOŚCI (patrz strona 41)

△ BEZPEČNOSTNÍ POKYNY

- △ Pro zabránění řezným zraněním a pohmožděninám je nutné při montáži nosit rukavice.
- △ Produkt nesmí být používán jako madlo. Je nutné namontovat samostatné madlo.

POKYNY K MONTÁŽI

- / Před montáží je třeba produkt zkontrolovat, zda nebyl při transportu poškozen. Po zabudování nebudou uznány žádné škody způsobené transportem nebo poškození povrchu.
- / Vedení a armatura musí být namontovány, propláchnuty a otestovány podle platných norem.
- / Je třeba dodržovat montážní pravidla platné v dané zemi.
- / Připojení pružnou hadicí kat. č. 58192000 (viz strana 34 Obr. A)

INSTALACE PODLE NORMY EN 1717 (viz strana 34 Obr. C)

- / Při montáži "iBox universal" s integrovanou bezpečnostní kombinací (HD) je nutno dbát na to, aby byl střed armatury min. 280 mm na okrajem vany.

POUŽITÍ ZKUŠEBNÍHO VTOKU

(viz strana 34 Obr. D)

- / Zkušební naplnění vany.
- / vypláchnout vedení
- / Tlaková zkouška potrubí mezi baterií a zkušebním vtokem
- / Proud zbytku vody je úmyslný. Má po tlakové zkoušce upozornit na zavření směšovače a zamezit křížovému toku směšovače.

TECHNICKÉ ÚDAJE

Výkon odtoku	53 l/min
výkon na přetoku	36 l/min

POPIS SYMBOLŮ



Nepoužívat silikon s obsahem kyseliny octové!



PŘÍKLADY MONTÁŽE
(viz strana 40)



ROZMĚRY (viz strana 32)



DIAGRAM PRŮTOKU (viz strana 32)



SERVISNÍ DÍLY (viz strana 39)

XXX = Kód povrchové úpravy

000 = Chrom

020 = Polished Chrome

130 = Polished Bronze

140 = Brushed Bronze

250 = Brushed Gold-Optic

260 = Brushed Chrome

300 = Polished Redgold

310 = Brushed Redgold

330 = Polished Black Chrome

340 = Brushed Black Chrome

800 = Stainless Steel Optic

820 = Brushed Nickel

830 = Polished Nickel

930 = Polished Brass

950 = Brushed Brass

990 = Polished Gold-Optic



ZVLÁŠTNÍ PŘÍSLUŠENSTVÍ
(viz strana 39) (není součástí dodávky)

- / Připojovací hadička kat.č. 58308000



ČIŠTĚNÍ (viz strana 36)



ZKUŠEBNÍ ZNAČKA (viz strana 41)

△ BEZPEČNOSTNÉ POKYNY

- △ Pri montáži musíte nosiť rukavice, aby ste predišli pomliaždeninám a rezným poraneniam.
- △ Výrobok sa nesmie používať ako držadlo. K tomu účelu sa musí namontovať samostatné držadlo.

POKYNY PRE MONTÁŽ

- / Pred montážou musíte produkt skontrolovať, či nebol počas transportu poškodený. Po zabudovaní nebudú uznané žiadne škody spôsobené transportom alebo poškodenia povrchu.
- / Potrubia a vybavenie musia byť namontované, prepláchnuté a vybavené v platnom normami.
- / Je potrebné dodržiavať smernice o inštalácii, ktoré sú práve teraz platné v krajinách.
- / pripojenie pomocou pružnej hadice výr. č. 58192000 (viď strana 34 Obr. A)

INŠTALÁCIA PODĽA DIN 1717

(viď strana 34 Obr. C)

- / Pri montáži iBox universal s integrovanou kombináciou istenia (HD) dbať na to, aby bol stred batérie min. 280 mm nad horným okrajom vane.

POUŽITĚ ZÁTKU (viď strana 34 Obr. D)

- / Skúšobné naplnenie vane.
- / Vypĺachnutie vedení.
- / Tlaková skúška potrubia medzi batériou a snímačom
- / Prúd zvýšenej vody pri tlakovej skúške je úmyselný. Má upozorniť na uzavretie miešadla po tlakovej skúške a zabrániť krížovému toku v miešadle.

TECHNICKÉ ÚDAJE

Výkon odtoku

53 l/min

výdatnosť prepadu

36 l/min

POPIS SYMBOLOV



Nepoužívať silikón s obsahom kyseliny octovej!



PRÍKLADY MONTÁŽE
(viď strana 40)



ROZMERY (viď strana 32)



DIAGRAM PRIETOKU
(viď strana 32)



SERVISNÉ DIELY (viď strana 39)

XXX = Farebné označenie

000 = Chróm

020 = Polished Chrome

130 = Polished Bronze

140 = Brushed Bronze

250 = Brushed Gold-Optic

260 = Brushed Chrome

300 = Polished Redgold

310 = Brushed Redgold

330 = Polished Black Chrome

340 = Brushed Black Chrome

800 = Stainless Steel Optic

820 = Brushed Nickel

830 = Polished Nickel

930 = Polished Brass

950 = Brushed Brass

990 = Polished Gold-Optic



ZVLÁŠTNE PRÍSLUŠENSTVO
(viď strana 39) (nie je súčasťou dodávky)

- / pripájacia hadička výrobné číslo 58308000



ČISTENIE (viď strana 36)



OSVEDČENIE O SKÚŠKE
(viď strana 41)



△ 安全技巧

- △ 装配时为避免挤压和切割受伤，必须戴上手套。
- △ 该产品不得作扶柄使用。必须安装单独的扶柄。

安装提示

- / 安装前必须检查产品是否受到运输损害。安装后将不认可运输损害或表面损伤。
- / 管道和阀门必须根据通用标准进行安装、冲洗和检查。
- / 请遵守当地国家现行的安装规定。
- / 与挠性软管连接。物品编号: 58192000 (参见第页 34 第 A)

按照EN 1717进行安装 (参见第页 34 第 C)

- / 组装iBox universal及整体式安全组合 (HD) 时请注意，龙头的中间至少在浴盆上沿上方280 mm。

冲洗塞的使用 (参见第页 34 第 D)

- / 浴盆试装满
- / 冲洗管道。
- / 龙头和嵌入式插头之间管道的压力测试
- / 压力检测时要注意剩余的水射流。在压力检测后应连接混合装置，避免混合装置处产生十字流。

技术参数

流出功率	53 升/分钟
溢水槽	36 升/分钟

符号说明



请勿使用含有乙酸的硅胶！



安装示意 (参见第页 40)



大小 (参见第页 32)



流量示意图 (参见第页 32)



备用零件 (参见第页 39)

XXX = 颜色代码

000 = 镀铬

020 = Polished Chrome

130 = Polished Bronze

140 = Brushed Bronze

250 = Brushed Gold-Optic

260 = Brushed Chrome

300 = Polished Redgold

310 = Brushed Redgold

330 = Polished Black Chrome

340 = Brushed Black Chrome

800 = Stainless Steel Optic

820 = Brushed Nickel

830 = Polished Nickel

930 = Polished Brass

950 = Brushed Brass

990 = Polished Gold-Optic



选装附件 (参见第页 39) (不在供货范围内)

连接软管 商品编号 58308000



清洗 (参见第页 36)



检验标记 (参见第页 41)

⚠ УКАЗАНИЯ ПО ТЕХНИКЕ БЕЗОПАСНОСТИ

- ⚠ Во время монтажа следует надеть перчатки во избежание прищемления и порезов.
- ⚠ Изделие запрещается использовать в качестве рукоятки. Следует устанавливать специальную рукоятку.

УКАЗАНИЯ ПО МОНТАЖУ

- / Перед монтажом следует проверить изделие на предмет повреждений при перевозке. После монтажа претензии о возмещении ущерба за повреждения при перевозке или повреждения поверхностей не принимаются.
- / Трубы и арматура должны быть установлены, промыты и проверены в соответствии с действующими нормами.
- / Необходимо соблюдать требования по монтажу, действующие в соответствующих странах.
- / Подключение с гибким шлангом. Арт № 58192000 (см. стр. 34 рис. А)

УСТАНОВКА, СОГЛАСНО EN 1717 (см. стр. 34 рис. С)

- / При монтаже iBox universal с встроенной предохраняющей комбинацией (HD) необходимо следить за тем, чтобы середина арматуры находилась на высоте мин. на 280 мм выше края ванны.

ИСПОЛЬЗОВАНИЕ ПРОБНОГО ВХОДА (см. стр. 34 рис. D)

- / Пробное наполнение ванны
- / Промывка трубопроводов
- / Проверка давления трубопровода между смесителем и пробным впуском
- / При проверке давления ожидается струя остаточной воды. Она должна напоминать о закрытии смесителя после проверки давления и предотвращать перекрестный поток в смесителе.

ТЕХНИЧЕСКИЕ ДАННЫЕ

Перерабатывающая способность 53 л/мин
 производительность перепускного устройства 36 л/мин

ОПИСАНИЕ СИМВОЛОВ



Не применяйте силикон, содержащий уксусную кислоту.



ВАРИАНТЫ УСТАНОВКИ (см. стр. 40)



РАЗМЕРЫ (см. стр. 32)



СХЕМА ПОТОКА (см. стр. 32)



КОМПЛЕКТ (см. стр. 39)

XXX = Цветная кодировка

000 = Хром

020 = Polished Chrome

130 = Polished Bronze

140 = Brushed Bronze

250 = Brushed Gold-Optic

260 = Brushed Chrome

300 = Polished Redgold

310 = Brushed Redgold

330 = Polished Black Chrome

340 = Brushed Black Chrome

800 = Stainless Steel Optic

820 = Brushed Nickel

830 = Polished Nickel

930 = Polished Brass

950 = Brushed Brass

990 = Polished Gold-Optic



СПЕЦИАЛЬНЫЕ ПРИНАДЛЕЖНОСТИ (см. стр. 39) (не включено в объем поставки!)

- / Подводка арт. № 58308000



ОЧИСТКА (см. стр. 36)



ЗНАК ТЕХНИЧЕСКОГО КОНТРОЛЯ (см. стр. 41)



△ TURVALLISUUSOHJEET

- △ Asennuksessa on käytettävä käsiineitä puristumien ja viiltojen aiheuttamien tapaturmien estämiseksi.
- △ Tuotetta ei saa käyttää kädensijana. On asennettava erillinen kädensija.

ASENNUSOHJEET

- / Ennen asennusta on tarkastettava tuotteen mahdolliset kuljetusvahingot. Asennuksen jälkeen kuljetus- ja pintavaurioita ei hyväksytä.
- / Putket ja hana on asennettava, huuhdeltava ja tarkastettava voimassa olevien standardien mukaisesti.
- / Jokaisessa maassa on noudatettava siellä päteviä asennusohjeita.
- / Liitäntä joustavalla letkulla. Tuotenumero 58192000 (katso sivu 34 kuva A)

ASENNUS NORMIN EN 1717 MUKAISESTI (katso sivu 34 kuva C)

- / Asennettaessa iBox universalia, jossa on integroitu turvayhdistelmä (HD), on huomioitava, että kalusteen keskipiste on min. 280 mm kylpyammeen reunan yläpuolella.

KOEJUOKSUPUTKEN KÄYTTÖ

(katso sivu 34 kuva D)

- / Ammeen koetäyttö
- / Johdotusten huuhtelu
- / Sekoittimen ja ammeen täyttöaukon välisessä putkessa olevan paineen mittausta
- / Jäännösvesisuihku on tarkoituksellinen, sen tarkoituksena on painetustauksen jälkeen muistuttaa sekoittimen sulkemisesta ja estää ristiinvirtaus sekoittimessa.

TEKNISET TIEDOT

Poistoteho	53 l/min
ylivalumamäärä	36 l/min

MERKIN KUVAUS



Älä käytä etikkahappopitoista silikonial



ASENNUSESIMERKKEJÄ
(katso sivu 40)



MITAT (katso sivu 32)



VIRTAUSDIAGRAMMI
(katso sivu 32)



VARAOSAT (katso sivu 39)

XXX = Värikoodaus

000 = Kromi

020 = Polished Chrome

130 = Polished Bronze

140 = Brushed Bronze

250 = Brushed Gold-Optic

260 = Brushed Chrome

300 = Polished Redgold

310 = Brushed Redgold

330 = Polished Black Chrome

340 = Brushed Black Chrome

800 = Stainless Steel Optic

820 = Brushed Nickel

830 = Polished Nickel

930 = Polished Brass

950 = Brushed Brass

990 = Polished Gold-Optic



ERITYISVARUSTE (katso sivu 39)
(ei kuulu toimitukseen)

- / Liitinletku tuotenumero 58308000



PUHDISTUS (katso sivu 36)



KOESTUSMERKKI (katso sivu 41)



△ SÄKERHETSANVISNINGAR

- △ Handskar ska bäras under monteringsarbetet så att man kan undvika kläm- och skärskador.
- △ Produkten får inte användas som handtag. Ett separat handtag måste monteras.

MONTERINGSANVISNINGAR

- / Det måste undersökas om produkten har transportskador innan den monteras. Efter monteringen accepteras inga transport- eller ytskiktsskador.
- / Ledningarna och blandaren måste monteras, spolas igenom och kontrolleras enligt de gällande normerna.
- / De installationsriktlinjer som gäller i länderna ska följas.
- / Anslutning med flexibel slang. Art.nr. 58192000 (se sidan 34 Bild A)

INSTALLATION ENLIGT EN 1717

(se sidan 34 Bild C)

- / När iBox universal med integrerad säkerhetskombination (HD) monteras är det viktigt att blandarens mitt på blandaren befinner sig min. 280 mm över karkanten.

ANVÄNDA TESTINLOPP (se sidan 34 Bild D)

- / Testifyll karet.
- / Spola ledningarna
- / Tryckkontroll i ledningen mellan blandare och testinlopp
- / Det ska finnas en restvattenstråle vid trycktesten. Den ska påminna om att blandaren ska stängas efter trycktesten och även undvika korsflöde i blandaren.

TEKNISKA DATA

Tömningskapacitet	53 l/min
överflödeseffekten	36 l/min

SYMBOLFÖRKLARING



Använd inte silikon som innehåller ättiksyra!



MONTERINGSEXEMPEL
(se sidan 40)



MÄTTEN (se sidan 32)



FLÖDESSCHEMA (se sidan 32)



RESERVDELAR (se sidan 39)

XXX = Färgkodning

000 = Krom

020 = Polished Chrome

130 = Polished Bronze

140 = Brushed Bronze

250 = Brushed Gold-Optic

260 = Brushed Chrome

300 = Polished Redgold

310 = Brushed Redgold

330 = Polished Black Chrome

340 = Brushed Black Chrome

800 = Stainless Steel Optic

820 = Brushed Nickel

830 = Polished Nickel

930 = Polished Brass

950 = Brushed Brass

990 = Polished Gold-Optic



SPECIALTILLBEHÖR (se sidan 39)
(medföljer ej leveransen)

- / Anslutningsslang artikelnummer 58308000



RENGÖRING (se sidan 36)



TESTSIGILL (se sidan 41)



△ SAUGUMO TECHNIKOS NURODYMAI

- △ Apsaugai nuo užspaudimo ir įsijovimo montavimo metu mūvėkite pirštines.
- △ Gaminys neturi būti naudojamas kaip rankena. Rankena montuojama atskirai.

MONTAVIMO INSTRUKCIJA

- / Prieš montuojant būtina patikrinti, ar gaminys nebuvo pažeistas transportavimo metu. Sumontavus pretenzijos dėl transportavimo ir paviršiaus pažeidimų nepriimamos.
- / Vamzdžiai ir sujungimai turi būti montuojami, plaunami ir tikrinami pagal galiojančias normas.
- / Laikykitės atitinkamoje šalyje galiojančių direktyvų dėl įrengimo.
- / Jungtis su lanksčiomis žarnos. Art. Nr. 58192000 (žr. psl. 34 Pav. A)

MONTAVIMAS PAGAL EN 1717 (žr. psl. 34 Pav. C)

- / Montuojant "Ibox universal" su integruota apsaugos sistema (HD), atkreipkite dėmesį, kad maišytuvo viduryje turi būti ne žemiau kaip 280 mm virš viršutiniojo vonios krašto.

NAUDOKITE BANDOMĄJĮ PALEIDIMĄ (žr. psl. 34 Pav. D)

- / Bandomasis vonios pripildymas.
- / Išplauti vamzdžius
- / Slėgio tikrinimas tarp maišytuvo ir jungties
- / Tikrinant slėgį, numatyta likusio vandens srovė. Ji turi priminti, jog patikrinus slėgį turi būti užvertas maišytuvas, kad jame nesusidarytų kryžminė srovė.

TECHNINIAI DUOMENYS

Išėjimo reikšmė	53 l/min
Išbėgančio vandens kiekis	36 l/min

SIMBOLIO APRAŠYMAS



Nenaudokite silikono, kurio sudėtyje yra acto rūgšties!



MONTAVIMO PAVYZDŽIAI (žr. psl. 40)



IŠMATAVIMAI (žr. psl. 32)



PRALAUDUMO DIAGRAMA (žr. psl. 32)



ATSARGINĖS DALYS (žr. psl. 39)

XXX = Spalvos
 000 = Chrom
 020 = Polished Chrome
 130 = Polished Bronze
 140 = Brushed Bronze
 250 = Brushed Gold-Optic
 260 = Brushed Chrome
 300 = Polished Redgold
 310 = Brushed Redgold
 330 = Polished Black Chrome
 340 = Brushed Black Chrome
 800 = Stainless Steel Optic
 820 = Brushed Nickel
 830 = Polished Nickel
 930 = Polished Brass
 950 = Brushed Brass
 990 = Polished Gold-Optic



SPECIALŪS PRIEDAI (žr. psl. 39) (nėra pridedama)

- / Prijungimo žarna Art.Nr. 58308000



VALYMAS (žr. psl. 36)



BANDYMO PAŽYMA (žr. psl. 41)



⚠ SIGURNOSNE UPUTE

- ⚠ Prilikom montaže se radi sprječavanja prignječenja i posjekotina moraju nositi rukavice.
- ⚠ Proizvod ne smije služiti za pridržavanje. U tu se svrhu mora postaviti zaseban rukohvat.

UPUTE ZA MONTAŽU

- / Prije montaže mora se provjeriti je li proizvod oštećen prilikom transporta. Nakon ugradnje se ne priznaju nikakve reklamacije koje se odnose na površinska i transportna oštećenja.
- / Cijevi i armatura moraju biti postavljeni, isprani i testirani prema važećim normama.
- / Obvezno se moraju uvažiti propisi o instalacijama koji vrijede u dotičnoj zemlji.
- / Spoj sa pomičnim crijevom, proizvod broj 58192000 (pogledaj stranicu 34 Sl. A)

INSTALACIJA PREMA STANDARDU EN 1717 (pogledaj stranicu 34 Sl. C)

- / Kod instalacije iBox universal-a sa ugrađenom sigurnosnom kombinacijom (HD) pripazite da se sredina armature nalazi minimalno 280 mm iznad ruba kade

KORISTITE PROBNI ZATVARAČ (pogledaj stranicu 34 Sl. D)

- / Probno punjenje kade
- / Ispiranje slavina
- / Ispitati tlak u cijevi između mješalice i zatvarača
- / Preostali vodeni mlaz je prilikom ispitivanja pod tlakom tako predviđen. On treba nakon ispitivanja pod tlakom podsjetiti na zatvaranje ručice kako bi se izbjeglo križno protjecanje na miješalici.

TEHNIČKI PODATCI

Protok vode	53 l/min
dozvoljeni kapacitet	36 l/min

OPIS SIMBOLA



Nemojte koristiti silikon koji sadrži octenu kiselinu!



PRIMJERI INSTALACIJA (pogledaj stranicu 40)



MJERE (pogledaj stranicu 32)



DIJAGRAM PROTOKA (pogledaj stranicu 32)



REZERVNI DJELOVI (pogledaj stranicu 39)

XXX = Boje
 000 = Krom
 020 = Polished Chrome
 130 = Polished Bronze
 140 = Brushed Bronze
 250 = Brushed Gold-Optic
 260 = Brushed Chrome
 300 = Polished Redgold
 310 = Brushed Redgold
 330 = Polished Black Chrome
 340 = Brushed Black Chrome
 800 = Stainless Steel Optic
 820 = Brushed Nickel
 830 = Polished Nickel
 930 = Polished Brass
 950 = Brushed Brass
 990 = Polished Gold-Optic



POSEBNI PRIBOR (pogledaj stranicu 39)
 (Nije sadržano u isporuci!)

- / Dovodna cijev br. Proizvoda 58308000



ČIŠĆENJE (pogledaj stranicu 36)



OZNAKA TESTIRANJA (pogledaj stranicu 41)

⚠ GÜVENLİK UYARILARI

- ⚠ Montaj esnasında ezilme ve kesilme gibi yaralanmaları önlemek için eldiven kullanılmalıdır.
- ⚠ Ürün tutma kolu olarak kullanılmamalıdır. Ayrı bir tutma kolu monte edilmelidir.

MONTAJ AÇIKLAMALARI

- / Montaj işleminden önce ürün nakliye hasarları yönünden kontrol edilmelidir. Montaj işleminden sonra nakliye veya yüzey hasarları için sorumluluk üstlenilmemektedir.
- / Boruların ve armatürün montajı, yıkanması ve kontrolü geçerli normlara göre yapılmalıdır.
- / Ülkelerde geçerli kurulum yönetmeliklerine riayet edilmelidir.
- / Esnek hortumlu bağlantı. Ürün kodu: 58192000 (bakınız sayfa 34 Şekil A)

DIN 1717'YE GÖRE MONTAJ (bakınız sayfa 34 Şekil C)

- / Entegre emniyet kombinasyonlu (HD) iBox universal'in montajı sırasında, batarya merkezinin küvet kenarından en az 280 mm yukarıda durmasına dikkat edilmelidir.

DENEME GİRİŞİNİ KULLANIN (bakınız sayfa 34 Şekil D)

- / Küveti deneme amaçlı doldurun.
- / Hatların yıkanması
- / Miks batarya ve deneme girişi arasındaki hattın basınç kontrolü
- / Kalan su akışı basınç kontrolü sırasında belirtilmiştir. Basınç kontrolünden sonra mikserin kapatılmasını hatırlatmalı ve mikserdeki çapraz akışı önlemelidir.

TEKNİK BİLGİLER

Çıkış gücü	53 l/dak
taşma kapasitesi	36 l/dak

SİMGE AÇIKLAMASI



Asetik asit içeren silikon kullanmayın!



MONTAJ ÖRNEĞİ (bakınız sayfa 40)



ÖLÇÜLERİ (bakınız sayfa 32)



AKIŞ DİYAGRAMI (bakınız sayfa 32)



YEDEK PARÇALAR (bakınız sayfa 39)

XXX = Renkler

000 = Krom

020 = Polished Chrome

130 = Polished Bronze

140 = Brushed Bronze

250 = Brushed Gold-Optic

260 = Brushed Chrome

300 = Polished Redgold

310 = Brushed Redgold

330 = Polished Black Chrome

340 = Brushed Black Chrome

800 = Stainless Steel Optic

820 = Brushed Nickel

830 = Polished Nickel

930 = Polished Brass

950 = Brushed Brass

990 = Polished Gold-Optic



ÖZEL AKSESUAR-
LAR (bakınız sayfa 39)
(Teslimat kapsamına dahil değildir)

- / Bağlantı hortumu Ürün kodu 58308000



TEMİZLEME (bakınız sayfa 36)



KONTROL İŞARETİ
(bakınız sayfa 41)



⚠ INSTRUCȚIUNI DE SIGURANȚĂ

- ⚠ La montare utilizați mănuși pentru evitarea contuziunilor și tăierii mâinilor.
- ⚠ Nu este permisă utilizarea produsului pe post de mâner. este nevoie de montarea unui mâner corespunzător.

INSTRUCȚIUNI DE MONTARE

- / Înainte de instalare verificați, dacă produsul prezintă deteriorări de transport. După instalare garanția nu acoperă deteriorările de transport și cele de suprafață.
- / Conductele și bateriile trebuie montate, spălate și verificate conform normelor în vigoare.
- / Respectați reglementările referitoare la instalare valabile în țara respectivă.
- / Conectare cu furtun flexibil. Cod produs: 58192000 (vezi pag. 34 Fig. A)

INSTALARE CONFORM EN 1717

(vezi pag. 34 Fig. C)

- / La montarea aparatului iBox universal cu combinație de securitare integrată (HD) aveți grijă ca mijlocul baterie să se afle cu min. 280 mm deasupra marginii căzii.

UTILIZAREA DOPULUI PENTRU CADA DE BAIE (vezi pag. 34 Fig. D)

- / Test de umplere a căzii de baie.
- / Spălarea conductelor
- / Verificarea presiunii în conducta dintre baterie și racordul de testare
- / La efectuarea probei de presiune trebuie avut în vedere jetul de apă reziduală. Pentru evitarea circulației transversale în amestecător, nu trebuie uitată închiderea amestecătorului după efectuarea probei de presiune.

DATE TEHNICE

Capacitate de evacuare	53 l/min
debit deversor	36 l/min

DESCRIEREA SIMBOLURILOR



Nu utilizați silicon cu conținut de acid acetic!



EXEMPLE DE MONTARE
(vezi pag. 40)



DIMENSIUNI (vezi pag. 32)



DIAGRAMA DE DEBIT
(vezi pag. 32)



PIESE DE SCHIMB (vezi pag. 39)

XXX = Coduri de culori

000 = Crom

020 = Polished Chrome

130 = Polished Bronze

140 = Brushed Bronze

250 = Brushed Gold-Optic

260 = Brushed Chrome

300 = Polished Redgold

310 = Brushed Redgold

330 = Polished Black Chrome

340 = Brushed Black Chrome

800 = Stainless Steel Optic

820 = Brushed Nickel

830 = Polished Nickel

930 = Polished Brass

950 = Brushed Brass

990 = Polished Gold-Optic



ACCESORII OPȚIONALE

(vezi pag. 39) (nu este inclus în setul livrat)



/ Furtun de racordare Nr. produs 58308000



CURĂȚARE (vezi pag. 36)



CERTIFICAT DE TESTARE

(vezi pag. 41)



ΔΥΠΟΔΕΙΞΕΙΣ ΑΣΦΑΛΕΙΑΣ

- Δ Για να αποφύγετε τραυματισμούς κατά τη συναρμολόγηση πρέπει να φοράτε γάντια.
- Δ Το προϊόν δεν επιτρέπεται να χρησιμοποιείται σαν λαβή στήριξης. Για τον σκοπό αυτό πρέπει να τοποθετηθεί ξεχωριστή λαβή στήριξης.

ΟΔΗΓΙΕΣ ΣΥΝΑΡΜΟΛΟΓΗΣΗΣ

- / Πριν τη συναρμολόγηση πρέπει να εξεταστεί το προϊόν για ζημιές μεταφοράς. Μετά την εγκατάσταση δεν αναγνωρίζονται ζημιές από τη μεταφορά ή επιφανειακές ζημιές.
- / Οι σωλήνες και η μπαταρία πρέπει να τοποθετηθούν σύμφωνα με τα ισχύοντα πρότυπα, να τεθούν υπό πίεση και να δοκιμαστούν.
- / Θα πρέπει να τηρούνται οι οδηγίες εγκατάστασης που ισχύουν σε κάθε κράτος.
- / Σύνδεση με εύκαμπτο σωλήνα. Αρ. είδους 58192000 (βλ. Σελίδα 34 εικ. Α)

ΕΓΚΑΤΑΣΤΑΣΗ ΣΥΜΦΩΝΑ ΜΕ ΤΟ ΠΡΟΤΥΠΟ EN 1717 (βλ. Σελίδα 34 εικ. C)

- / Κατά τη συναρμολόγηση του iBox universal με ενσωματωμένο συνδυασμό ασφαλείας (HD), θα πρέπει να δώσετε προσοχή, ώστε το μέσον της βάνας να προεξέχει από το χέλιος της μπανιέρας κατά ελάχιστη απόσταση 280 mm.

ΧΡΗΣΗ ΤΗΣ ΔΟΚΙΜΑΣΤΙΚΗΣ ΠΛΗΡΩΣΗΣ ΜΕ ΝΕΡΟ (βλ. Σελίδα 34 εικ. D)

- / Δοκιμαστική πλήρωση της μπανιέρας.
- / Καθαρισμός των αγωγών
- / Έλεγχος πίεσης του αγωγού μεταξύ μπαταρίας (μείκτη) και δοκιμαστικής εισόδου νερού
- / Η δέσμη του υπόλοιπου νερού που εξέρχεται κατά τη δοκιμή πίεσης είναι σκόπιμη. Σκοπό έχει να υπενθυμίζει το κλείσιμο του αναμίκτη μετά τη δοκιμή πίεσης για να αποφεύγονται διασταυρώσεις στη ροή του νερού στον αναμίκτη.

ΤΕΧΝΙΚΑ ΧΑΡΑΚΤΗΡΙΣΤΙΚΑ

Απόδοση απορροής	53 l/min
ροή υπερχειλίσης	36 l/min

ΠΕΡΙΓΡΑΦΗ ΣΥΜΒΟΛΩΝ



Μην χρησιμοποιείτε σιλικόνη που περιέχει οξικό οξύ!



ΠΑΡΑΔΕΙΓΜΑΤΑ ΣΥΝΑΡΜΟΛΟΓΗΣΗΣ (βλ. Σελίδα 40)



ΔΙΑΣΤΑΣΕΙΣ (βλ. Σελίδα 32)



ΔΙΑΓΡΑΜΜΑ ΡΟΗΣ (βλ. Σελίδα 32)



ΑΝΤΑΛΛΑΚΤΙΚΑ (βλ. Σελίδα 39)

XXX = Χρώμα

000 = Επιχρωμωμένο

020 = Polished Chrome

130 = Polished Bronze

140 = Brushed Bronze

250 = Brushed Gold-Optic

260 = Brushed Chrome

300 = Polished Redgold

310 = Brushed Redgold

330 = Polished Black Chrome

340 = Brushed Black Chrome

800 = Stainless Steel Optic

820 = Brushed Nickel

830 = Polished Nickel

930 = Polished Brass

950 = Brushed Brass

990 = Polished Gold-Optic



ΕΙΔΙΚΑ ΑΞΕΣΟΥΑΡ (βλ. Σελίδα 39)
(δεν περιλαμβάνεται στον παραδοτέο εξοπλισμό)



/ Εύκαμπτος σωλήνας παροχής αρ. είδους 58308000



ΚΑΘΑΡΙΣΜΟΣ (βλ. Σελίδα 36)



ΣΗΜΑ ΕΛΕΓΧΟΥ (βλ. Σελίδα 41)



△ VARNOSTNA OPOZORILA

- △ Pri montaži je treba nositi rokavice, da se preprečijo poškodbe zaradi zmečkanja ali urezov.
- △ Proizvoda ne smete uporabljati kot držalnega ročaja. V ta namen je treba montirati poseben ročaj.

NAVODILA ZA MONTAŽO

- / Pred montažo je treba izdelek preveriti glede morebitnih transportnih poškodb. Po vgradnji transportne ali površinske poškodbe ne bodo več priznane.
- / Cevi in armaturo je treba montirati, izprati in preveriti po veljavnih standardih.
- / Upoštevati je treba pravilnike o inštalacijah, ki veljajo v posamezni državi.
- / Priključek z upogljivo cevjo št. art. 58192000 (glejte stran 34 Sl. A)

MONTAŽA PO EN 1717 (glejte stran 34 Sl. C)

- / Pri montaži iBox universalna z vgrajeno varnostno kombinacijo (HD) je potrebno paziti, da leži sredina armature min. 280 mm čez rob kadi.

UPORABA PRESKUSNEGA DOTOKA (glejte stran 34 Sl. D)

- / Testno polnjenje kadi
- / Izpiranje cevi
- / Testiranje tlaka v napeljavi med mešalno baterijo in poskusnim dotokom
- / Ostanek vodnega curka pri tlačnem preizkusu je namenski. Opozarja, da je treba po tlačnem preizkusu zapreti mešalni ventil in preprečuje križni pretok na ventilu.

TEHNIČNI PODATKI

Odtočna zmogljivost	53 l/min
zogljivost preliva	36 l/min

OPIS SIMBOLA



Ne smete uporabiti silikona, ki vsebuje ocatno kislino!



PRIMERI MONTAŽE (glejte stran 40)



MERE (glejte stran 32)



DIAGRAM PRETOKA (glejte stran 32)



REZERVNI DELI (glejte stran 39)

XXX = Barve
 000 = Krom
 020 = Polished Chrome
 130 = Polished Bronze
 140 = Brushed Bronze
 250 = Brushed Gold-Optic
 260 = Brushed Chrome
 300 = Polished Redgold
 310 = Brushed Redgold
 330 = Polished Black Chrome
 340 = Brushed Black Chrome
 800 = Stainless Steel Optic
 820 = Brushed Nickel
 830 = Polished Nickel
 930 = Polished Brass
 950 = Brushed Brass
 990 = Polished Gold-Optic



POSEBEN PRIBOR (glejte stran 39)
 (Ni vključeno)

- / Priključna gibka cev številka artikla 58308000



ČIŠČENJE (glejte stran 36)



PRESKUSNI ZNAK (glejte stran 41)

△ OHUTUSJUHISED

- △ Kandke paigaldamisel muljumis- ja löikevigastuste vältimiseks kindaid.
- △ Toodet ei tohi kasutada käepidemena. Paigaldage eraldi käepide.

PAIGALDAMISJUHISED

- / Enne paigaldamist tuleb toodet kontrollida transpordikahjustuste osas. Pärast paigaldamist ei tunnustata enam transpordi- või pinnakahjustuste kaebuseid.
- / Voolikute ja segisti paigaldamisel, loputamisel ja kontrollimisel tuleb lähtuda kehtivatest normatiividest.
- / Vastavas riigis kehtivaid paigalduseeskirju tuleb järgida.
- / painduva voolikuga ühendus art nr 58192000 (vt lk 34 Joonis A)

PAIGALDAMINE VASTAVALT STANDAR-DILE EN 1717 (vt lk 34 Joonis C)

- / Ibox universal'i ühendamisel integreeritud ohutuskombinatsiooniga (HD) jälgige, et segisti kese oleks vähemalt 280 mm üle vanni serva (vt kõrvalolevat joonist).

PROOVISISSEVOOLU KASUTAMINE

(vt lk 34 Joonis D)

- / Vanni proovitäitmine.
- / Torude loputamine
- / Segisti ja uhtekorgi vaheliste torude survetest
- / Jäakvee juga survekontrolli ajal on ette nähtud. See peab meenutama segisti sulgemists pärast survekontrolli ja takistama ristvoolu segistis.

TEHNILISED ANDMED

Äravooluvõimsus	53 l/min
ülevool	36 l/min

SÜMBOLITE KIRJELDUS



Ärge kasutage äädikhapet sisaldavat silikoonil



PAIGALDUSE NÄITED (vt lk 40)



MÕÖTUDE (vt lk 32)



LÄBIVOOLUDIAGRAMM (vt lk 32)



VARUOSAD (vt lk 39)

XXX = Värvid

000 = Kroom

020 = Polished Chrome

130 = Polished Bronze

140 = Brushed Bronze

250 = Brushed Gold-Optic

260 = Brushed Chrome

300 = Polished Redgold

310 = Brushed Redgold

330 = Polished Black Chrome

340 = Brushed Black Chrome

800 = Stainless Steel Optic

820 = Brushed Nickel

830 = Polished Nickel

930 = Polished Brass

950 = Brushed Brass

990 = Polished Gold-Optic



SPETSIAALNE LISAVARUSTUS

(vt lk 39) (ei sisaldu komplektis)



/ ühendusvoolik artikli number 58308000



PUHASTAMINE (vt lk 36)



KONTROLLSERTIFIKAAT (vt lk 41)



△ DROŠĪBAS NORĀDES

- △ Montāžas laikā, lai izvairītos no saspiedumiem un iegrīzumiem, nepieciešams nēsāt cimdus.
- △ Šo produktu nedrīkst izmantot kā roku balstu. Nepieciešams uzmontēt atsevišķu roku balstu.

NORĀDĪJUMI MONTĀŽAI

- / Pirms montāžas nepieciešams pārbaudīt, vai produktam transportēšanas laikā nav radušies bojājumi. Pēc iebūvēšanas bojājumi, kas radušies transportēšanas laikā, vai virsmas bojājumi netiek atzīti.
- / Caurulvadi un armatūra ir jāuzstāda, jāizskalo un jāpārbauda saskaņā ar spēkā esošajiem standartiem.
- / Jāievēro attiecīgās valstīs spēkā esošās montāžas prasības.
- / Pieslēgums ar elastīgu šļūteni. Art. Nr. 58192000 (skat. lpp. 34 Att. A)

INSTALĀCIJA SASKAŅĀ AR EN 1717 (skat. lpp. 34 Att. C)

- / Montējot iBox universal ar integrēto drošības kombināciju (HD) ir jāievēro, lai jāucējkrāna vidus atrastos min. 280 mm virs vannas malas.

KONTROLIETEKAS IZMANTOŠANA (skat. lpp. 34 Att. D)

- / Dušas paliktņa kontrole, iepildot ūdeni.
- / Ūdens vada skalošana
- / Spiediena pārbaude ūdens vadā starp jāucējkrānu un kontrolieeju
- / Atlikušā ūdens strūkļa spiediena pārbaudes laikā ir ar nolūku. Tai jāatgādina par jāucējkrāna aizvēršanu pēc spiediena pārbaudes un jānovērš krustveida plūsma jāucējkrānā.

TEHNISKIE DATI

Aizplūdes iespējas	53 l/min
pārplūdes ierīces jauda	36 l/min

SIMBOLU NOZĪME



Neizmantot silikonu, kas satur etiķskābi!



MONTĀŽAS PIEMĒRI (skat. lpp. 40)



IZMĒRUS (skat. lpp. 32)



CAURPLŪDES DIAGRAMMA (skat. lpp. 32)



REZERVES DAĻAS (skat. lpp. 39)

XXX = Krāsu kodi

000 = Hroma

020 = Polished Chrome

130 = Polished Bronze

140 = Brushed Bronze

250 = Brushed Gold-Optic

260 = Brushed Chrome

300 = Polished Redgold

310 = Brushed Redgold

330 = Polished Black Chrome

340 = Brushed Black Chrome

800 = Stainless Steel Optic

820 = Brushed Nickel

830 = Polished Nickel

930 = Polished Brass

950 = Brushed Brass

990 = Polished Gold-Optic



SPECIĀLI AKSESUĀRI

(skat. lpp. 39) (komplektā netiek piegādāts)



TĪRĪŠANA (skat. lpp. 36)



PĀRBAUDES ZĪME (skat. lpp. 41)

⚠ SIGURNOSNE NAPOMENE

- ⚠ Prilikom montaže se radi sprečavanja prignječenja i posekotine moraju nositi rukavice.
- ⚠ Proizvod se ne sme koristiti za kao ručka za pridržavanje. U tu svrhu se mora postaviti zaseban rukohvat.

INSTRUKCIJE ZA MONTAŽU

- / Pre montaže se mora proveriti da li je proizvod oštećen pri transportu. Nakon ugradnje se ne priznaju nikakve reklamacije koje se odnose na površinska i transportna oštećenja.
- / Vodovi i armatura moraju biti postavljeni, isprani i testirani prema važećim normama.
- / Treba se pridržavati propisa koji u određenim zemljama važe za instalacije.
- / Priključak s fleksibilnim crevom. Br. proizvoda 58192000 (vidi stranu 34 Sl. A)

INSTALACIJA PREMA STANDARDU EN 1717 (vidi stranu 34 Sl. C)

- / Kada instalirate iBox universal s ugrađenom sigurnosnom kombinacijom (HD), pripazite da se sredina armature nalazi minimalno 280 mm iznad ivice kade.

KORIŠĆENJE PROBNOG DOTOKA (vidi stranu 34 Sl. D)

- / Probno punjenje kade
- / Ispiranje cevi
- / Ispitati pritisak u cevi između mešača i probnog dotoka
- / Preostali vodeni mlaz je namerno predviđen za ispitivanje pod pritiskom. On treba po završetku ispitivanja pod pritiskom da podseti na zatvaranje mešača, kako bi se na njemu izbegao unakrsni protok.

TEHNIČKI PODACI

Kapacitet odvoda	53 l/min
kapacitet kade	36 l/min

OPIS SIMBOLA



Nemojte koristiti silikon koji sadrži sircetnu kiselinu!



PRIMERI MONTAŽE (vidi stranu 40)



MERE (vidi stranu 32)



DIJAGRAM PROTOKA (vidi stranu 32)



REZERVNI DELOVI (vidi stranu 39)

XXX = Oznake boja

000 = Hrom

020 = Polished Chrome

130 = Polished Bronze

140 = Brushed Bronze

250 = Brushed Gold-Optic

260 = Brushed Chrome

300 = Polished Redgold

310 = Brushed Redgold

330 = Polished Black Chrome

340 = Brushed Black Chrome

800 = Stainless Steel Optic

820 = Brushed Nickel

830 = Polished Nickel

930 = Polished Brass

950 = Brushed Brass

990 = Polished Gold-Optic



POSEBAN PRIBOR (vidi stranu 39)
(Nije sadržano u isporuci)

- / Priključno crevo br. Proizvoda 58308000



ČIŠĆENJE (vidi stranu 36)



ISPITNI ZNAK (vidi stranu 41)

△ SIKKERHETSHENVISNINGER

- △ Bruk hansker under montasjen for å unngå klem- og kuttskader.
- △ Produktet skal ikke brukes som holdegrep. Det skal monteres en separat holdegrep.

MONTAGEHENVISNINGER

- / Før montasjen skal produktet sjekkes for transportskader. Etter monteringen aksepteres ikke noen transport- eller overflateskader.
- / Ledningene og armaturen skal monteres, spyles og sjekkes iht. de gyldige normer.
- / Gjeldende retningslinjer for rørleggerarbeid i de enkelte land skal følges.
- / Tilkobling med fleksibel slange artikkel-nr. 58192000 (se side 34 Bilde A)

INSTALLASJON IHT. EN 1717

(se side 34 Bilde C)

- / Ved montering av iBox universal med integrert sikkerhetskombinasjon (HD) skal man påse at midten på armaturen er minst 280 mm over badekarkanten.

BRUK AV PRØVEINNLLØP (se side 34 Bilde D)

- / Prøvefylling av badekar.
- / Spyling av ledninger
- / Trykkkontroll av ledningen mellom blande batteri og prøveinnløp
- / Det er mening med en restvannstråle under trykkprøven. Det skal minne deg om at blande batteriet lukkes igjen etter trykkprøven, slik at man forhindrer krysstrømning i blande batteriet.

TEKNISKE DATA

Avløpskapasitet	53 l/min
overfyllingsfunksjon	36 l/min

SYMBOLBESKRIVELSE



Ikke bruk silikon som inneholder eddiksyre!



MONTASJE- EKSEMPEL (se side 40)



MÅL (se side 32)



GJENNOMSTRØMNINGSDIAGRAM (se side 32)



SERVICEDELER (se side 39)

XXX = Fargekode

000 = Krom

020 = Polished Chrome

130 = Polished Bronze

140 = Brushed Bronze

250 = Brushed Gold-Optic

260 = Brushed Chrome

300 = Polished Redgold

310 = Brushed Redgold

330 = Polished Black Chrome

340 = Brushed Black Chrome

800 = Stainless Steel Optic

820 = Brushed Nickel

830 = Polished Nickel

930 = Polished Brass

950 = Brushed Brass

990 = Polished Gold-Optic



EKSTRATILBEHØR (se side 39)
(ikke med i leveransen)

- / Tilkoblingslange Artikkelnummer 58308000



RENGJØRING (se side 36)



PRØVEMERKE (se side 41)



⚠ УКАЗАНИЯ ЗА БЕЗОПАСНОСТ

- ⚠ При монтажа трябва да се носят ръкавици, за да се избегнат наранявания поради притискане или порязване.
- ⚠ Продуктът не бива да се използва като дръжка. Трябва да се монтира отделна дръжка.

УКАЗАНИЯ ЗА МОНТАЖ

- / Преди монтажа продуктът трябва да се провери за транспортни щети. След монтажа не се признават транспортни или повърхностни щети.
- / Тръбопроводите и арматурата трябва да се монтират, промият и проверят в съответствие с валидните норми.
- / Трябва да бъдат спазвани валидните в съответните страни предписания за инсталиране.
- / Свързване с гъвкав маркуч. Ном. № 58192000 (вижте стр. 34 фиг. А)

ИНСТАЛАЦИЯ ПО EN 1717

(вижте стр. 34 фиг. С)

- / При монтажа на iBox universal с интегриран комплект предпазители (HD) обърнете внимание на това, средата на арматурата да се намира мин. 280 мм над ръба на стената.

ИЗПОЛЗВАЙТЕ ПРОБНИЯ ВХОДЯЩ НАКРАЙНИК (вижте стр. 34 фиг. D)

- / Пробно пълнене на ваната.
- / Промиване на тръбопроводите
- / Проверка на налягането на водопровода между смесителя и пробното захранване
- / Струята остатъчна вода при проверка на налягането е предвидена. Тя трябва да напомня за затварянето на смесителя след проверка на налягането и да предотврати кръстосване на потока при смесителя.

ТЕХНИЧЕСКИ ДАННИ

Мощност на изтичане	53 л/мин
мощност на преливане	36 л/мин

ОПИСАНИЕ НА СИМВОЛИТЕ



Не използвайте силикон, съдържащ оцетна киселина!



ПРИМЕРИ ЗА МОНТАЖ (вижте стр. 40)



РАЗМЕРИ (вижте стр. 32)



ДИАГРАМА НА ПОТОКА (вижте стр. 32)



СЕРВИЗНИ ЧАСТИ (вижте стр. 39)

XXX = Цветово кодиране
 000 = Хром
 020 = Polished Chrome
 130 = Polished Bronze
 140 = Brushed Bronze
 250 = Brushed Gold-Optic
 260 = Brushed Chrome
 300 = Polished Redgold
 310 = Brushed Redgold
 330 = Polished Black Chrome
 340 = Brushed Black Chrome
 800 = Stainless Steel Optic
 820 = Brushed Nickel
 830 = Polished Nickel
 930 = Polished Brass
 950 = Brushed Brass
 990 = Polished Gold-Optic



СПЕЦИАЛНИ ПРИНАДЛЕЖНОСТИ (вижте стр. 39)
 (не се съдържа в обема на доставка)

- / Свързващ маркуч Номенклатурен номер 58308000



ПОЧИСТВАНЕ (вижте стр. 36)



КОНТРОЛЕН ЗНАК (вижте стр. 41)

△ UDHËZIME SIGURIE

- △ Për të evituar lëndimet e pickimeve ose të prerjeve gjatë procesit të montimit duhet që të vishni doreza.
- △ Produkti nuk duhet të përdoret si dorëze mbajtëse. Duhet të montohet një dorëzë mbajtëse e veçantë

UDHËZIME PËR MONTIMIN

- / Përpara montimit duhet që produkti të kontrollohet për dëmtime nga transporti. Pas instalimit nuk do të njihet asnjë dëmtim nga transporti ose dëmtim i sipërfaqes.
- / Tubacionet dhe rubinetet duhet që të montohen, të shpëlahen dhe të kontrollohen sipas standardeve në fuqi
- / Duhet të respektohen linjat udhëzuese të instalimit, të vlefshme për vendet respektive.
- / Lidhje me tuba të lakueshëm. Art. Nr. 58192000 (shih faqen 34 Fig. A)

INSTALIMI SIPAS NORMAVE EN 1717 (shih faqen 34 Fig. C)

- / Gjatë montimit të iBox universale me kombinim të masave të integruara të sigurisë (HD) duhet pasur parasysh që mesi i armaturës të qëndrojë min. 280 mm mbi buzën e vaskës.

PËRDORIMI I HYRJES SË UJIT PËR PROVË (shih faqen 34 Fig. D)

- / Mbushje për provë e vaskës.
- / Shpëlarja e lidhjeve
- / Kontrolli i presionit të lidhjes mes rubinetit me ujë të përzier dhe hyrjes së ujit për provë
- / Është marrë në konsideratë currili i ujit të mbetur gjatë kontrollit të presionit. Ai ka për qëllim paralajmërojë që duhet mbyllur rubineti pas kontrollit të presionit për të evituar një rrjedhje të kryqëzuar.

TË DHËNA TEKNIKE

Shkarkimi në dalje	53 l/min
kapaciteti i vendrrjedhjes së ujit të tepërt	36 l/min

PËRSHKRIMI I SIMBOLIT



Mos përdorni silikon që në përbërje ka acid acetik.



SHEMBUJ TË MONTIMIT (shih faqen 40)



PËRMASAT (shih faqen 32)



DIAGRAMI I QARKULLIMIT (shih faqen 32)



PJESËT E SERVISIT (shih faqen 39)

XXX = Kodimi me anë të ngjyrave
 000 = Krom
 020 = Polished Chrome
 130 = Polished Bronze
 140 = Brushed Bronze
 250 = Brushed Gold-Optic
 260 = Brushed Chrome
 300 = Polished Redgold
 310 = Brushed Redgold
 330 = Polished Black Chrome
 340 = Brushed Black Chrome
 800 = Stainless Steel Optic
 820 = Brushed Nickel
 830 = Polished Nickel
 930 = Polished Brass
 950 = Brushed Brass
 990 = Polished Gold-Optic



PAJISJE TË POSAÇME (shih faqen 39)

(nuk përfshihet në vëllimin e furnizimit)

- / Zorra e lidhjes Numri i artikullit 58308000





PASTRIMI (shih faqen 36)



SHENJA E KONTROLLIT (shih faqen 41)

وصف الرمز

هام! لا تستخدم السليكون الذي يحتوي على أحماض! 

مثال على التركيب (راجع صفحة 40) 

أبعاد (راجع صفحة 32) 

رسم للصراف (راجع صفحة 32) 

قطع الغيار (راجع صفحة 39) 

الألوان = XXX

كروم = 000

Polished Chrome = 020

Polished Bronze = 130

Brushed Bronze = 140

Brushed Gold-Optic = 250

Brushed Chrome = 260

Polished Redgold = 300

Brushed Redgold = 310

Polished Black Chrome = 330

Brushed Black Chrome = 340

Stainless Steel Optic = 800

Brushed Nickel = 820

Polished Nickel = 830

Polished Brass = 930

Brushed Brass = 950

Polished Gold-Optic = 990

ملحقات خاصة (راجع صفحة 39) 

(غير مدرج مع المحتويات المسلمة)

/ خرطوم التوصيل رقم الصنف 58308000

التنظيف (راجع صفحة 36) 

شهادة اختبار (راجع صفحة 41) 

تنبيهات الأمان

⚠ يجب إرتداء قفازات لليد أثناء التركيب لتجنب حدوث أخطار الإنحشار أو الجروح

⚠ ممنوع إستخدام المنتج كمقبض. يجب تركيب مقبض منفصل.

تعليمات التركيب

/ قبل القيام بعملية التركيب، يجب فحص المنتج للتأكد من خلوّه من أية تلفيات ناتجة عن النقل بعد القيام بعملية التركيب، لن يتم الاعتراف بوجود أية تلفيات سطحية أو تلفيات ناتجة عن عملية النقل.

/ يجب تركيب وغسيل واختيار التوصيلات وخلطات المياه طبقاً للمعايير السارية.

/ يجب مراعاة القواعد الخاصة بالتركيب وأعمال السباكة وفقاً للوائح الخاصة بكل بلد.

/ التوصيل مع خرطوم مرن رقم الطلب 58192000 (راجع صفحة 34 انظر الصورة رقم A)

التركيب وفقاً للمواصفة EN 1717

(راجع صفحة 34 انظر الصورة رقم C)

/ عند تجميع iBox universal مع مجموعة الأمان المتكاملة (HD) يرجى الانتباه إلى أن ارتفاع منتصف الخلاط عن الحافة العليا لحوض الاستحمام يجب ألا يقل عن 280 مم.

استخدام سداد التدفق

(راجع صفحة 34 انظر الصورة رقم D)

/ اختبار البانبيو عند الامتلاء.

/ غسيل المواسير.

/ اختبار ضغط المواسير بين الخلاط وسداد الطرد

/ يتم التخطيط للسماح باندفاع للنسبة المتبقية من المياه عند إجراء اختبار الضغط حيث أن ذلك يذكر المستخدم بإغلاق الخلاط بعد إجراء الاختبار، كما يعمل على تجنب التدفق العكسي.

المواصفات الفنية

53 لتر / الدقيقة

36 لتر / الدقيقة

قدرة تسيير

سعة حوض الاستحمام



التركيب (راجع صفحة 33)

△ BIZTONSÁGI UTASÍTÁSOK

- △ A szerelésnél a zúzódások és vágási sérülések elkerülése érdekében kesztyűt kell viselni.
- △ A terméket nem szabad kapaszkodónak használni. Ehhez külön kapaszkodót kell felszerelni.

SZERELÉSI UTASÍTÁSOK

- / A szerelés előtt ellenőrizni kell, hogy a terméknek nincs-e szállítási sérülése. Beépítés után a szállítási- vagy felületi sérüléseket nem ismerik el.
- / A vezetékeket és a csaptelepet az érvényes szabványoknak megfelelően kell felszerelni, öblíteni és ellenőrizni
- / Az egyes országokban érvényes installációs irányelveket be kell tartani.
- / Csatlakozó flexibilis tömlővel, Cikkszám: 58192000 (lásd a oldalon 34 ábra A)

SZERELÉS EN 1717 SZERINT

(lásd a oldalon 34 ábra C)

- / A beépített biztonsági kombinációval (HD) ellátott iBox universal szerelésekor arra kell ügyelni, hogy a csaptelep közepe legalább 280 mm-rel a kád pereme felett fekjüdjön.

PRÓBABEÖMLŐ ALKALMAZÁSA

(lásd a oldalon 34 ábra D)

- / A kád próbatöltése.
- / A vezetékek öblítése
- / A vezeték nyomásellenőrzése a keverő és a próba-beömlés között
- / A nyomáspróbakor a maradékvíz-sugár szándékos. Emlékeztetnie kell a nyomáspróba után a keverő elzárására, és meg kell akadályoznia a keverőnél a keresztátfolyást.

MŰSZAKI ADATOK

Lefolyási teljesítmény	53 l/perc
túlfolyó teljesítmény	36 l/perc

SZIMBÓLUMOK LEÍRÁSA



Ne használjon ecetsavtartalmú szilikon!



SZERELÉSI PÉLDÁK
(lásd a oldalon 40)



MÉRETET (lásd a oldalon 32)



ÁTFOLYÁSI DIAGRAM
(lásd a oldalon 32)



TARTOZÉKOK (lásd a oldalon 39)

XXX = Színkódolás

000 = Króm

020 = Polished Chrome

130 = Polished Bronze

140 = Brushed Bronze

250 = Brushed Gold-Optic

260 = Brushed Chrome

300 = Polished Redgold

310 = Brushed Redgold

330 = Polished Black Chrome

340 = Brushed Black Chrome

800 = Stainless Steel Optic

820 = Brushed Nickel

830 = Polished Nickel

930 = Polished Brass

950 = Brushed Brass

990 = Polished Gold-Optic



EGYÉB TARTOZÉK
(lásd a oldalon 39)

(a szállítási egység nem tartalmazza)

- / Bekötőcső cikkszám 58308000



TISZTÍTÁS (lásd a oldalon 36)



VIZSGAJEL (lásd a oldalon 41)



△ 安全上の注意

- △ 施工の際は手を挟んだり怪我をしないように、手袋をはめてください。
- △ 製品は取っ手として使用できません。必要に応じて別途取っ手を設置してください。

施工上の注意

- / 製品の施工前に輸送でのダメージがないか確認してください。施工後のキズ等のお申し出はお断りさせていただきます。
- / 配管と水栓は、関連法規に従って施工、洗浄、および試験を行ってください。
- / 施工行う地域に適用される関連法規をお守りください。
- / 部品番号58192000のフレキシブルホースとの接続(次のページを参照 34 図 A)

DIN 1717に準拠した施工(次のページを参照 34 図 C)

- / 逆流防止装置を備えたiBoxを施工する際は、水栓の中心を浴槽の上端から280 mm以上離してください(日本では関連法規に従って施工してください)。

洗浄プラグの使用(次のページを参照 34 図 D)

- / 浴槽の水溜め確認。
- / 配管の洗浄
- / 混合栓と排水プラグ間の耐圧試験
- / 圧力テスト中に残水が出ます。これは圧力テスト後に水栓を閉じることの注意喚起と、水栓内部でのクロスコネクションを防止するためです。

技術資料

排水能力	53 リットル分
排水能力に関して	36 リットル分

アイコンの説明



酢酸系シリコンをご使用にならないでください!



施工例(次のページを参照 40)



寸法(次のページを参照 32)



流量曲線図(次のページを参照 32)



スペアパーツ(次のページを参照 39)

XXX = 仕上げ色

000 = Chrome

020 = Polished Chrome

130 = Polished Bronze

140 = Brushed Bronze

250 = Brushed Gold-Optic

260 = Brushed Chrome

300 = Polished Redgold

310 = Brushed Redgold

330 = Polished Black Chrome

340 = Brushed Black Chrome

800 = Stainless Steel Optic

820 = Brushed Nickel

830 = Polished Nickel

930 = Polished Brass

950 = Brushed Brass

990 = Polished Gold-Optic



スペシャルパーツ(次のページを参照 39)
(別手配部品)

/ 接続ホース 品番 58308000



お手入れ方法(次のページを参照 36)



認証について(次のページを参照 41)

施工方法(次のページを参照 33)





AXOR Exafill
58303XXX

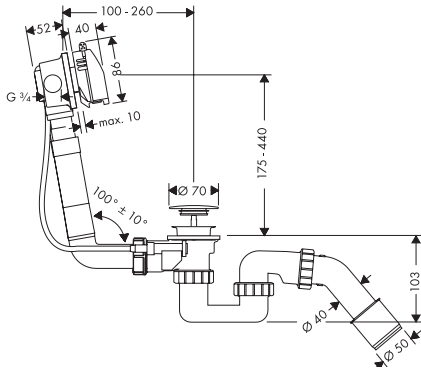

AXOR Exafill
58300XXX

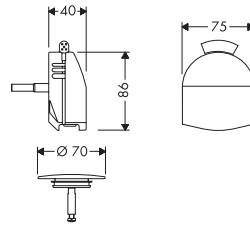

AXOR Exafill
58301180

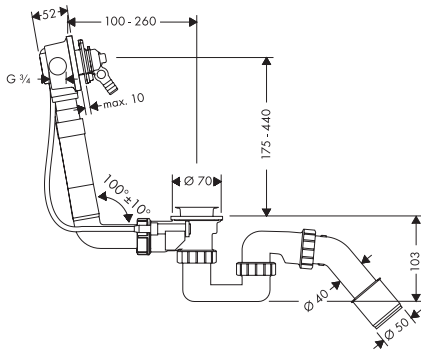

AXOR Exafill
58302180

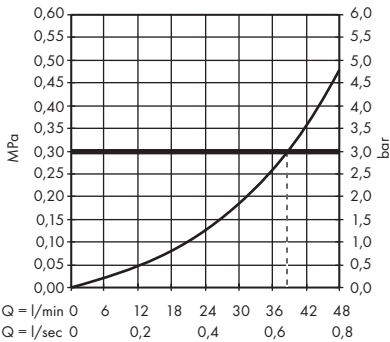
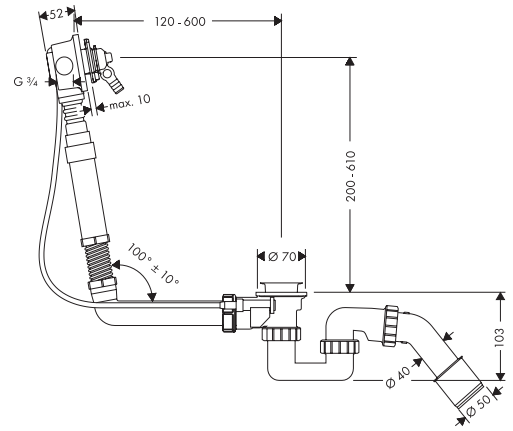

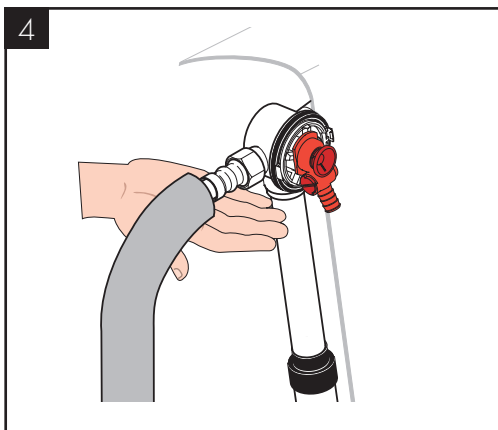
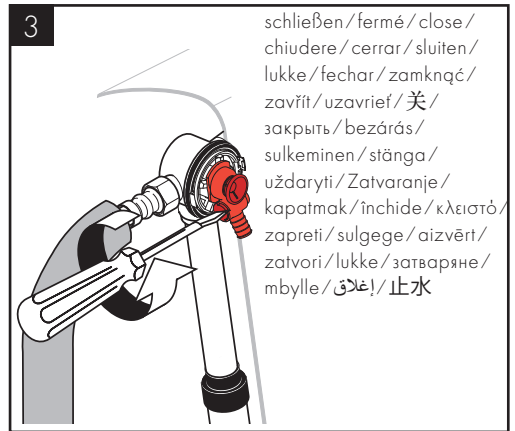
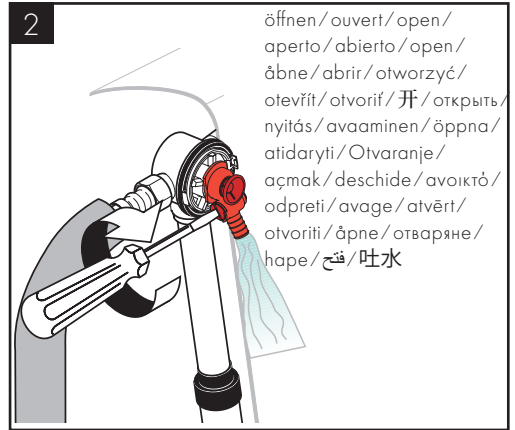
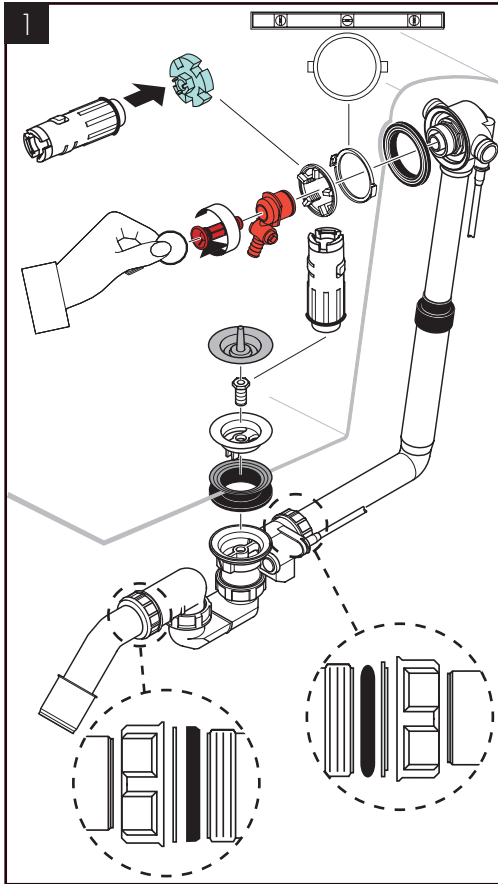

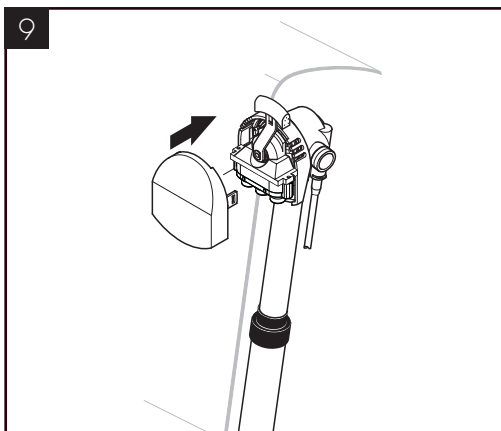
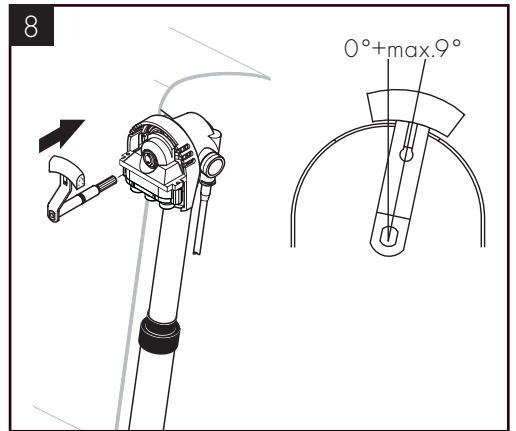
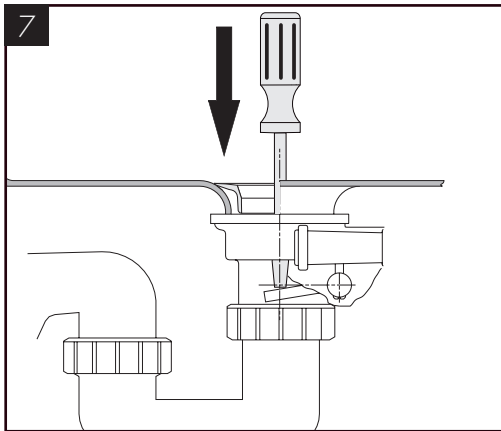
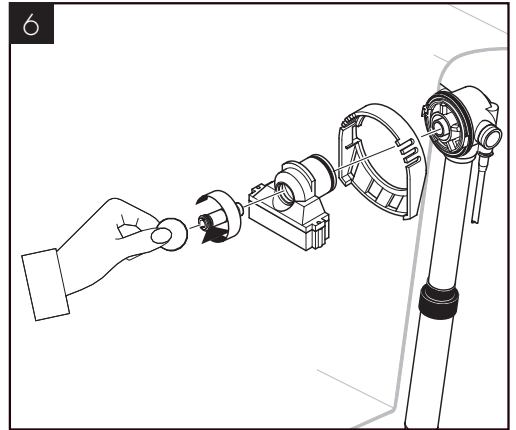
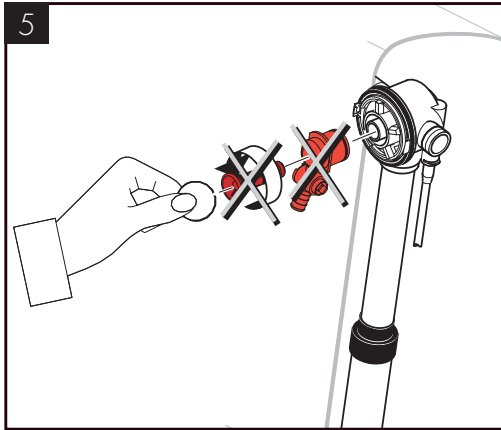

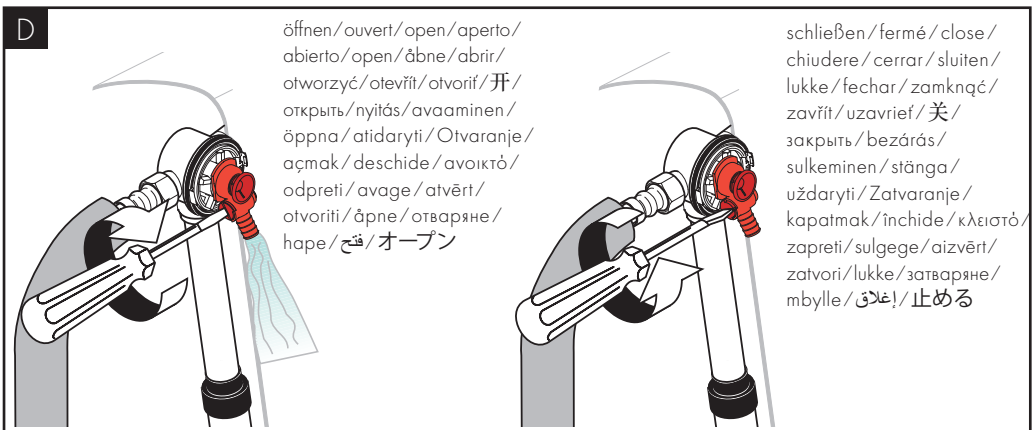
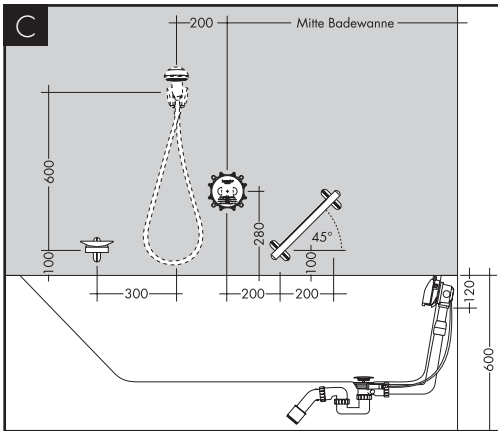
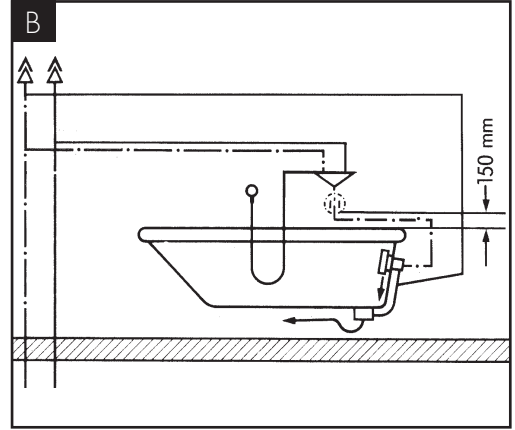
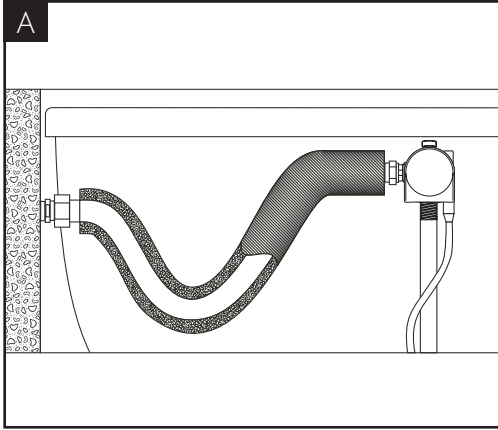

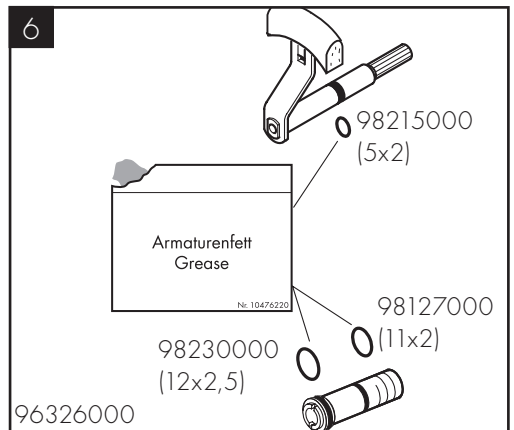
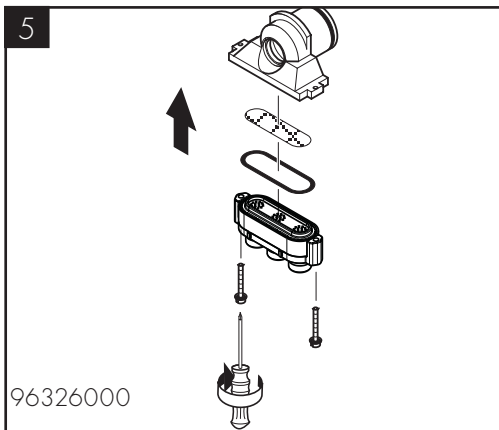
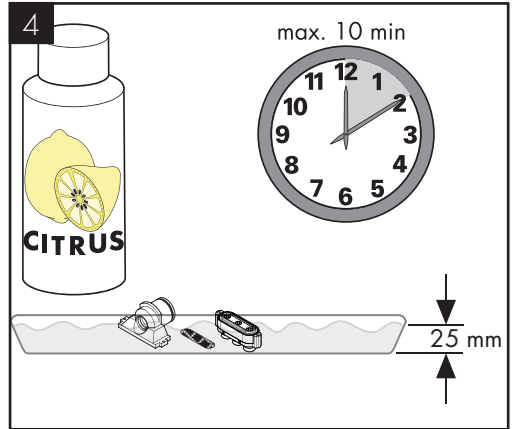
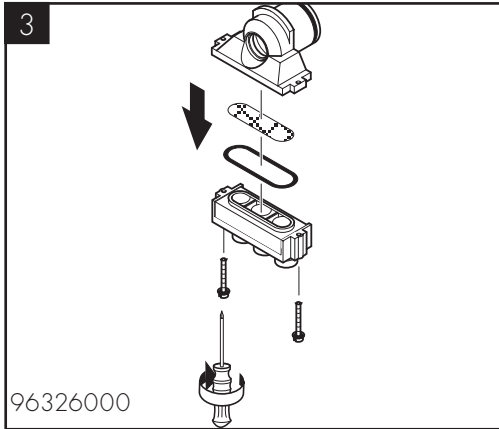
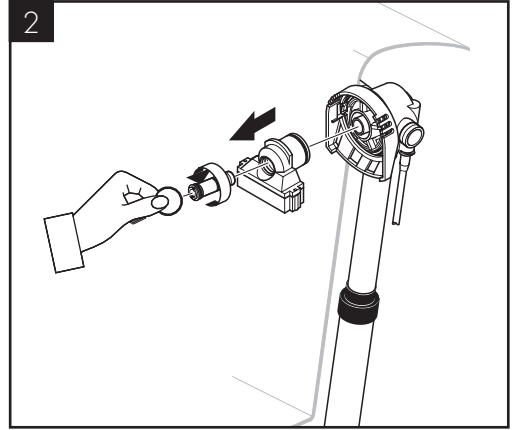
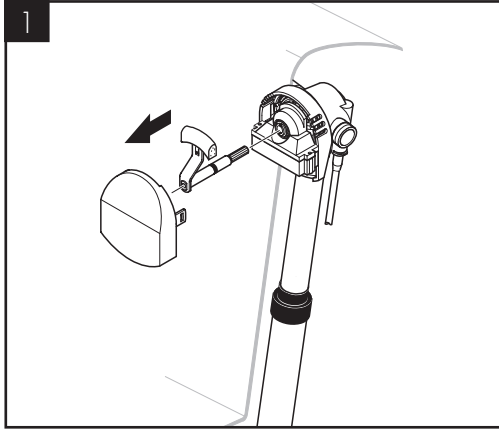

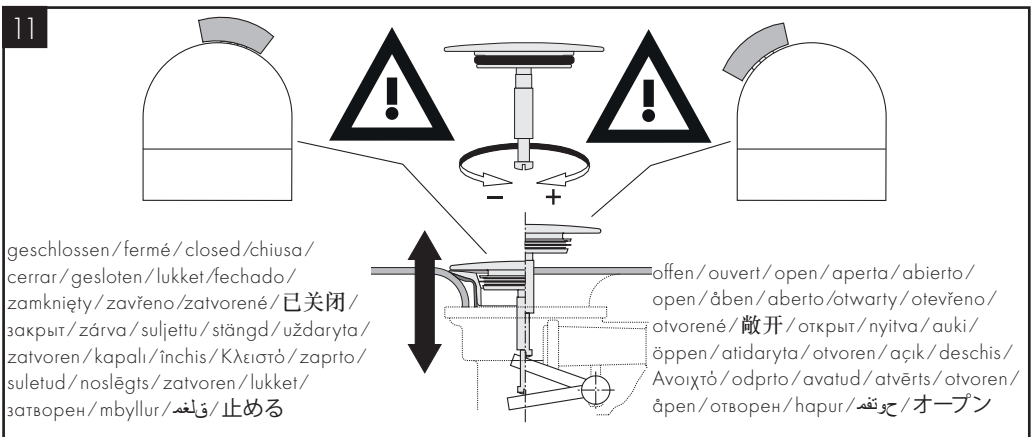
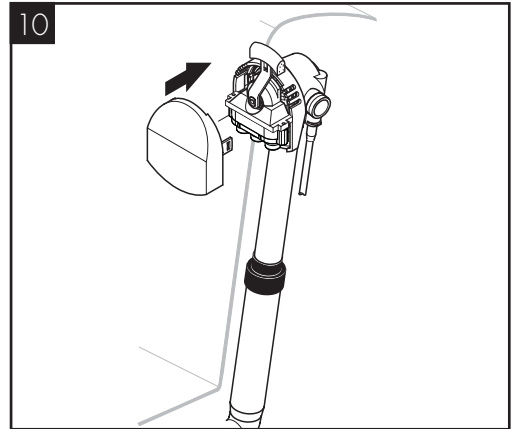
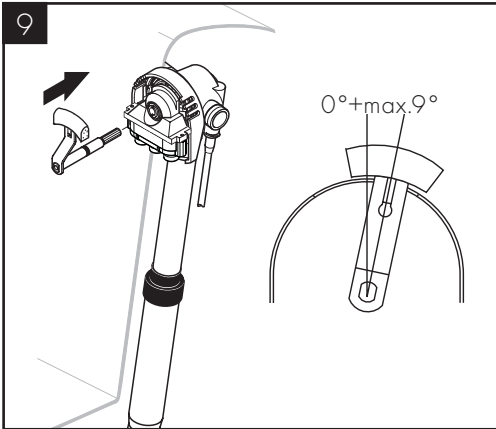
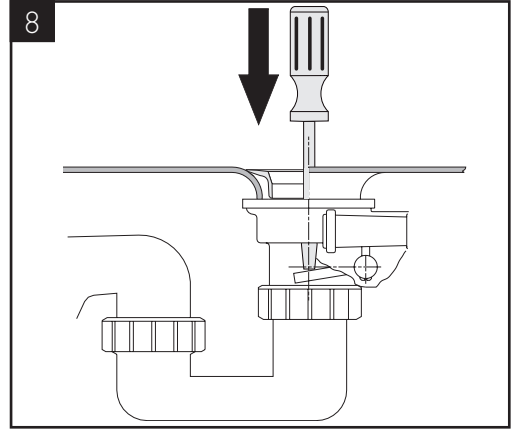
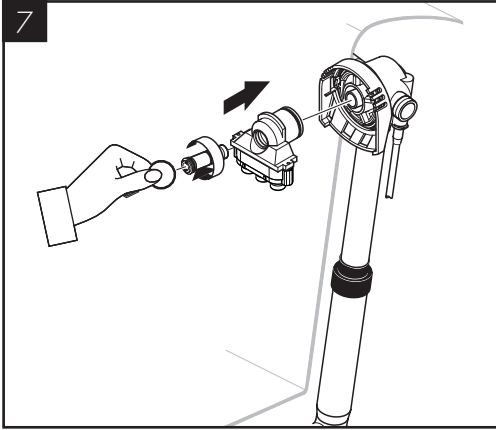



DE / Reinigungsempfehlung / Garantie / Kontakt
 FR / Recommandation pour le nettoyage / Garanties / Contact
 EN / Cleaning recommendation / Warranty / Contact
 IT / Raccomandazione di pulizia / Garanzia / Contatto
 ES / Recomendaciones para la limpieza / Garantía / Contacto
 NL / Aanbevelingen inzake reiniging / Garantie / Contact
 DK / Rensning, anbefaling / Garanti / Kontakt
 PT / Recomendações de limpeza / Garantia / Contacto
 PL / Zalecenie dotyczące pielęgnacji / Gwarancja / Kontakt
 CS / Doporučení k čištění / Záruka / Kontakt
 SK / Odporúčania pre čistenie / Záruka / Kontakt
 ZH / 清洁指南 / 担保 / 接触
 RU / Рекомендации по очистке / Гарантия / Контакты
 FI / Puhdistussuositus / Takuu / Kosketus
 SV / Rengöringsrekommendationer / Garanti / Contacto
 LT / Valymo rekomendacijos / Garantija / Kontaktai
 HR / Preporuke za čišćenje / Garancija / Kontakt
 TR / Temizleme önerisi / Garanti / Temas
 RO / Recomandări pentru curățare / Garanție / Contact
 EL / Σύσταση καθαρισμού / Εγγύηση / επαφή
 SL / Priporočilo za čiščenje / Garancija / Kontakt
 ET / Puhastussoovitused / Garantii / Kontakt
 LV / Tīrīšanas ieteikumi / Garantija / Kontakti
 SR / Preporuke za čišćenje / Garancija / Kontakt
 NO / Anbefaling for rengjøring / Garanti / Kontakt
 BG / Препоръка за почистване / Гаранция / Контакт
 SQ / Këshilla rreth pastrimit / Garancia / Kontakt
 KO / 세정시 권장사항 / 품질보증 / 접촉
 AR / توصيات التنظيف / الضمان (الولايات المتحدة الأمريكية) / اتصال
 HU / Tisztítási tanácsok / Garancia / érintkezés
 JP / お手入れの方法 / 保証について / ご連絡先

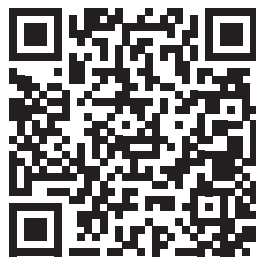

[www.axor-design.com/
cleaning-recommendation](http://www.axor-design.com/cleaning-recommendation)

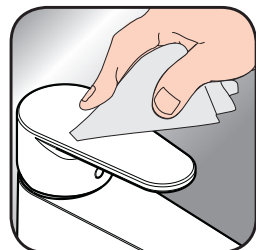

[www.axor-design.com/
cleaning-recommendation](http://www.axor-design.com/cleaning-recommendation)



[www.axor-design.com/
cleaning-recommendation](http://www.axor-design.com/cleaning-recommendation)



[www.axor-design.com/
cleaning-recommendation](http://www.axor-design.com/cleaning-recommendation)

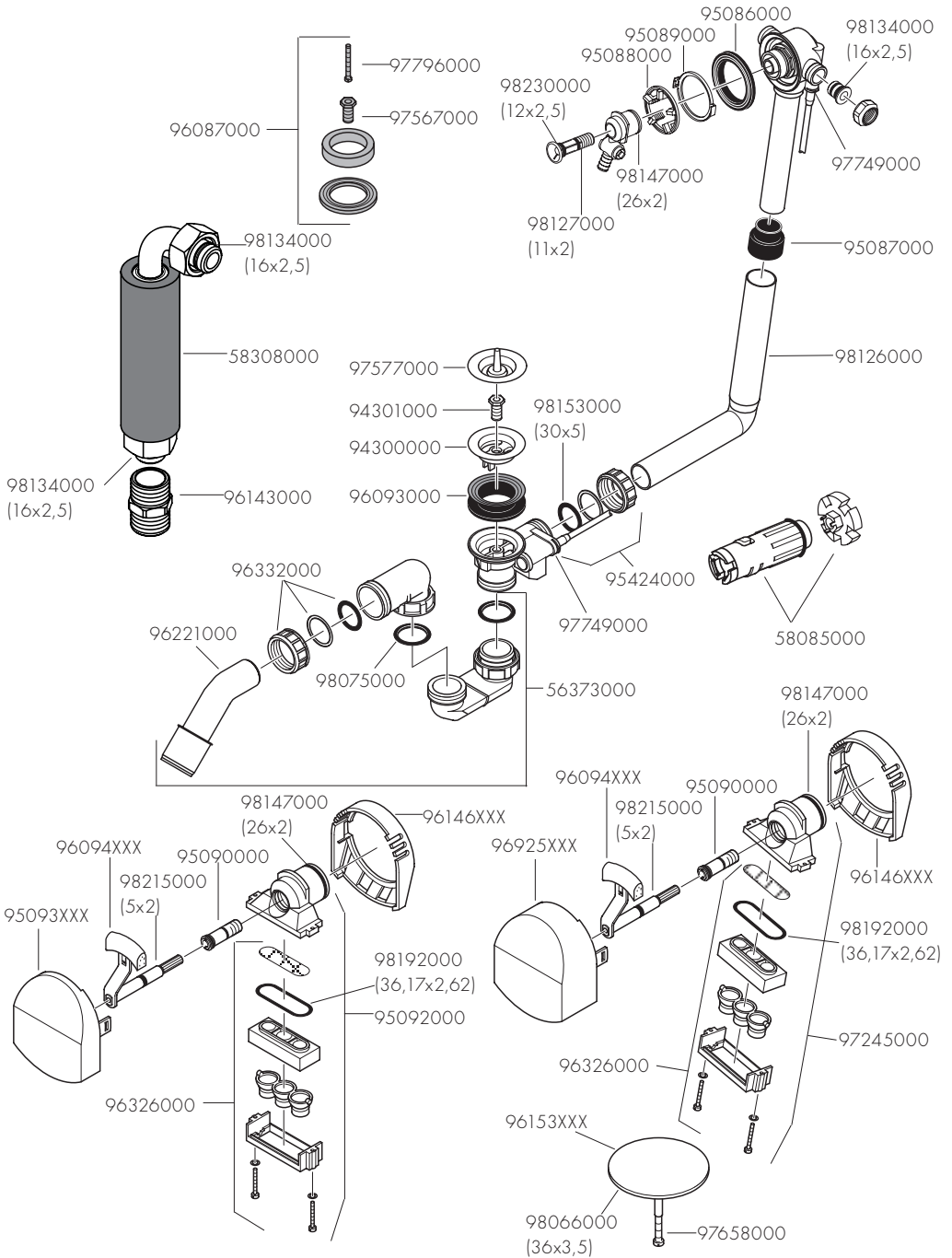

Axor Exafill + iBox universal

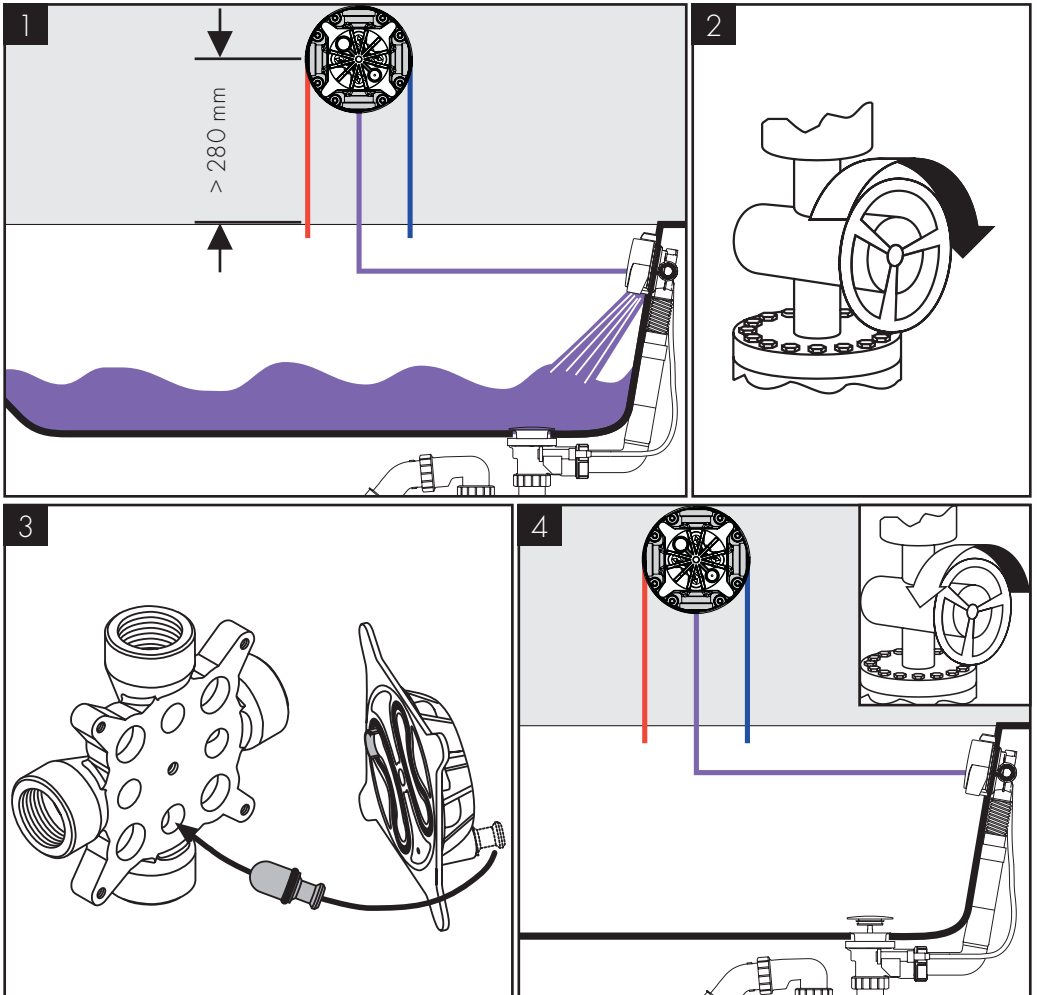
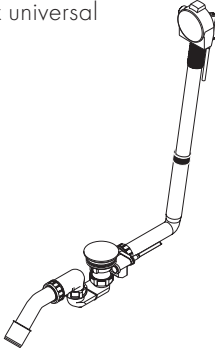



P-IX

DVGW

SINTEF

NF



ETA

GODKENDT
TIL DRIKKEVAND

58300XXX	P-IX 19141/1		X	X
58303XXX	P-IX 19141/1		X	X
58301180				X



AXOR

AXOR / Hansgrohe SE
Austraße 5-9
77761 Schiltach
Deutschland

info@axor-design.com
axor-design.com

09/2020
9119295.01