

AXOR

DE / Gebrauchsanleitung / Montageanleitung	02
FR / Mode d'emploi / Instructions de montage	02
EN / Instructions for use / Assembly instructions	03
IT / Istruzioni per l'uso / Istruzioni per Installazione	03
ES / Modo de empleo / Instrucciones de montaje	04
NL / Gebruiksaanwijzing / Handleiding	04
DK / Brugsanvisning / Monteringsvejledning	05
PT / Instruções para uso / Manual de Instalação	05
PL / Instrukcja obsługi / Instrukcja montażu	06
CS / Návod k použití / Montážní návod	06
SK / Návod na použitie / Montážny návod	07
ZH / 用户手册 / 组装说明	07
RU / Руководство пользователя / Инструкция по монтажу	08
FI / Käyttöohje / Asennusohje	08
SV / Bruksanvisning / Monteringsanvisning	09
LT / Vartotojo instrukcija / Montavimo instrukcijos	09
HR / Upute za uporabu / Uputstva za instalaciju	10
RO / Manual de utilizare / Instrucțiuni de montare	10
EL / Οδηγίες χρήσης / Οδηγία συναρμολόγησης	11
SL / Navodilo za uporabo / Navodila za montažo	11
ET / Kasutusjuhend / Paigaldusjuhend	12
LV / Lietošanas pamācība / Montāžas instrukcija	12
SR / Uputstvo za upotrebu / Uputstvo za montažu	13
NO / Bruksanvisning / Montasjeveiledning	13
BG / Инструкция за употреба / Ръководство за монтаж	14
JP / 取扱説明書 / 施工説明書	14
SQ / Udhëzuesi i përdorimit / Udhëzime rreth montimit	15
AR / دليل الاستخدام / تعليمات التجميع	15
TR / Kullanım kılavuzu / Montaj kılavuzu	16
HU / Használati útmutató / Szerelési útmutató	17



AXOR Citerio
39740XXX

INSTALLATION

△ SICHERHEITSHINWEISE

- △ Bei der Montage müssen zur Vermeidung von Quetsch- und Schnittverletzungen Handschuhe getragen werden.
- △ Das Produkt darf nur zu Bade-, Hygiene- und Körperreinigungszwecken eingesetzt werden.
- △ Große Druckunterschiede zwischen den Kalt- und Warmwasseranschlüssen müssen ausgeglichen werden.

MONTAGEHINWEISE

- / Vor der Montage muss das Produkt auf Transportschäden untersucht werden. Nach dem Einbau werden keine Transport- oder Oberflächenschäden anerkannt.
- / Die Leitungen und die Armatur müssen nach den gültigen Normen montiert, gespült und geprüft werden.
- / Die in den Ländern jeweils gültigen Installationsrichtlinien sind einzuhalten.

TECHNISCHE DATEN

Betriebsdruck:	max. 0,6 MPa
Empfohlener Betriebsdruck:	0,2 - 0,4 MPa
Heißwassertemperatur:	max. 60°C

SYMBOLERKLÄRUNG

MASSE (siehe Seite 19)



DURCHFLUSSDIAGRAMM
(siehe Seite 19)



SERVICETEILE (siehe Seite 23)

- XXX = Farbcodierung
- 000 = Chrom
- 140 = Brushed Bronze
- 250 = Brushed Gold-Optic
- 300 = Polished Redgold
- 310 = Brushed Redgold
- 330 = Polished Black Chrome
- 340 = Brushed Black Chrome
- 800 = Stainless Steel Optic
- 820 = Brushed Nickel
- 830 = Polished Nickel
- 930 = Polished Brass
- 950 = Brushed Brass
- 990 = Polished Gold-Optic



REINIGUNG (siehe Seite 20)

MONTAGE

(siehe Seite 18)

**△ CONSIGNES DE SÉCURITÉ**

- △ Lors du montage, porter des gants de protection pour éviter toute blessure par écrasement ou coupure.
- △ Le produit ne doit servir qu'à se laver et à assurer l'hygiène corporelle.
- △ Il est conseillé d'équilibrer les pressions de l'eau chaude et froide.

INSTRUCTIONS POUR LE MONTAGE

- / Avant son montage, s'assurer que le produit n'a subi aucun dommage pendant le transport. Après le montage, tout dommage de transport ou de surface ne pourra pas être reconnu.
- / Les conduites et la robinetterie doivent être montés, rincés et contrôlés selon les normes en vigueur.
- / Les directives d'installation en vigueur dans le pays concerné doivent être respectées.

INFORMATIONS TECHNIQUES

Pression de service autorisée:	max. 0,6 MPa
Pression de service conseillée:	0,2 - 0,4 MPa
Température d'eau chaude:	max. 60°C

DESCRIPTION DU SYMBOLE

DIMENSIONS (voir pages 19)



DIAGRAMME DU DÉBIT
(voir pages 19)



PIÈCES DÉTACHÉES (voir pages 23)

- XXX = Couleurs
- 000 = Chromé
- 140 = Brushed Bronze
- 250 = Brushed Gold-Optic
- 300 = Polished Redgold
- 310 = Brushed Redgold
- 330 = Polished Black Chrome
- 340 = Brushed Black Chrome
- 800 = Stainless Steel Optic
- 820 = Brushed Nickel
- 830 = Polished Nickel
- 930 = Polished Brass
- 950 = Brushed Brass
- 990 = Polished Gold-Optic



NETTOYAGE (voir pages 20)

MONTAGE

(voir pages 18)



△ SAFETY NOTES

- △ Gloves should be worn during installation to prevent crushing and cutting injuries.
- △ The product may only be used for bathing, hygienic and body cleaning purposes.
- △ The hot and cold supplies must be of equal pressures.

INSTALLATION INSTRUCTIONS

- / Prior to installation, inspect the product for transport damages. After it has been installed, no transport or surface damage will be honoured.
- / The pipes and the fixture must be installed, flushed and tested as per the applicable standards.
- / The plumbing codes applicable in the respective countries must be observed.

TECHNICAL DATA

Operating pressure:	max. 0,6 MPa
Recommended operating pressure:	0,2 - 0,4 MPa
Hot water temperature:	max. 60°C

SYMBOL DESCRIPTION



DIMENSIONS (see page 19)



FLOW DIAGRAM (see page 19)



SPARE PARTS (see page 23)

XXX = Colors

000 = Chrome Plated

140 = Brushed Bronze

250 = Brushed Gold-Optic

300 = Polished Redgold

310 = Brushed Redgold

330 = Polished Black Chrome

340 = Brushed Black Chrome

800 = Stainless Steel Optic

820 = Brushed Nickel

830 = Polished Nickel

930 = Polished Brass

950 = Brushed Brass

990 = Polished Gold-Optic



CLEANING (see page 20)

△ INDICAZIONI SULLA SICUREZZA

- △ Durante il montaggio, per evitare ferite da schiacciamento e da taglio bisogna indossare guanti protettivi.
- △ Il prodotto deve essere utilizzato esclusivamente per fare il bagno e per l'igiene del corpo.
- △ Attenzione! Compensare le differenze di pressione tra i collegamenti dell'acqua fredda e dell'acqua calda.

ISTRUZIONI PER IL MONTAGGIO

- / Prima del montaggio è necessario controllare che non ci siano stati danni durante il trasporto. Una volta eseguito il montaggio, non verranno riconosciuti eventuali danni di trasporto o delle superfici.
- / Montare, lavare e controllare tubature e rubinetteria rispettando le norme correnti.
- / Vanno rispettate le direttive di installazione nazionali vigenti nel rispettivo paese.

DATI TECNICI

Pressione d'uso:	max. 0,6 MPa
Pressione d'uso consigliata:	0,2 - 0,4 MPa
Temperatura dell'acqua calda:	max. 60°C

DESCRIZIONE SIMBOLO



INGOMBRI (vedi pagg. 19)



DIAGRAMMA FLUSSO
(vedi pagg. 19)



PARTI DI RICAMBIO
(vedi pagg. 23)

XXX = Trattamento

000 = Cromato

140 = Brushed Bronze

250 = Brushed Gold-Optic

300 = Polished Redgold

310 = Brushed Redgold

330 = Polished Black Chrome

340 = Brushed Black Chrome

800 = Stainless Steel Optic

820 = Brushed Nickel

830 = Polished Nickel

930 = Polished Brass

950 = Brushed Brass

990 = Polished Gold-Optic



PULITURA (vedi pagg. 20)

ASSEMBLY

(see page 18)



MONTAGGIO

(vedi pagg. 18)



INDICACIONES DE SEGURIDAD

- △ Durante el montaje deben utilizarse guantes para evitar heridas por aplastamiento o corte.
- △ El producto solo debe ser utilizado para fines de baño, higiene y limpieza corporal.
- △ Grandes diferencias de presión en servicio entre agua fría y agua caliente deben equilibrarse.

INDICACIONES PARA EL MONTAJE

- / Antes del montaje se debe examinar el producto contra daños de transporte. Después de la instalación no se reconoce ningún daño de transporte o de superficie.
- / Los conductos y la grifería deben montarse, lavarse y comprobarse según las normas vigentes.
- / Es obligatorio el cumplimiento de las directrices de instalación vigentes en el país respectivo.

DATOS TÉCNICOS

Presión en servicio:	max. 0,6 MPa
Presión recomendada en servicio:	0,2 - 0,4 MPa
Temperatura del agua caliente:	max. 60°C

DESCRIPCIÓN DE SÍMBOLOS

 **DIMENSIONES** (ver página 19)

 **DIAGRAMA DE CIRCULACIÓN**
(ver página 19)

 **REPUESTOS** (ver página 23)

- XXX = Acabados
- 000 = Cromado
- 140 = Brushed Bronze
- 250 = Brushed Gold-Optic
- 300 = Polished Redgold
- 310 = Brushed Redgold
- 330 = Polished Black Chrome
- 340 = Brushed Black Chrome
- 800 = Stainless Steel Optic
- 820 = Brushed Nickel
- 830 = Polished Nickel
- 930 = Polished Brass
- 950 = Brushed Brass
- 990 = Polished Gold-Optic

 **LIMPIAR** (ver página 20)

MONTAJE

(ver página 18)

**VEILIGHEIDSLINSTRUCTIES**

- △ Bij de montage moeten ter voorkoming van knel- en snijwonden handschoenen worden gedragen.
- △ Het product mag alleen voor het wassen, hygiënische doeleinden en voor de lichaamreiniging worden gebruikt.
- △ Grote drukverschillen tussen de koud- en warmwater-toevoer dienen vermeden te worden.

MONTAGE-INSTRUCTIES

- / Vóór de montage moet het product gecontroleerd worden op transportschade. Na de inbouw wordt geen transport- of oppervlakteschade meer aanvaard.
- / De leidingen en armaturen moeten gemonteerd, gespoeld en gecontroleerd worden volgens de geldige normen.
- / De in de overeenkomstige landen geldende installatie-richtlijnen moeten nageleefd worden.

TECHNISCHE GEGEVENEN

Werkdruk:	max. 0,6 MPa
Aanbevolen werkdruk:	0,2 - 0,4 MPa
Temperatuur warm water:	max. 60°C

SYMBOOLBESCHRIJVING

 **MATEN** (zie blz. 19)

 **DOORSTROOMDIAGRAM**
(zie blz. 19)

 **SERVICE ONDERDELEN**
(zie blz. 23)

- XXX = Kleuren
- 000 = Verchroomd
- 140 = Brushed Bronze
- 250 = Brushed Gold-Optic
- 300 = Polished Redgold
- 310 = Brushed Redgold
- 330 = Polished Black Chrome
- 340 = Brushed Black Chrome
- 800 = Stainless Steel Optic
- 820 = Brushed Nickel
- 830 = Polished Nickel
- 930 = Polished Brass
- 950 = Brushed Brass
- 990 = Polished Gold-Optic

 **REINIGEN** (zie blz. 20)

MONTAGE

(zie blz. 18)



△ SIKKERHEDSANVISNINGER

- △ Ved monteringen skal der bruges handsker for at undgå kvæstelser og snitsår.
- △ Produktet må kun bruges til bade-, hygiejne og kropsurengøring.
- △ Større trykforskelle mellem koldt og varmt vand bør udjævnes.

MONTERINGSANVISNINGER

- / Før monteringen skal produktet kontrolleres for transportskader. Efter monteringen godkendes transportskader eller skader på overfladen ikke længere.
- / Ledningerne og armaturerne skal monteres, skylles og kontrolleres iht. de gældende standarder.
- / Installationsbestemmelserne, der gælder i det enkelte land, skal overholdes.

TEKNISKE DATA

Driftstryk:	max. 0,6 MPa
Anbefalet driftstryk:	0,2 - 0,4 MPa
Varmtvandstemperatur:	max. 60°C

SYMBOLBESKRIVELSE



MÅLENE (se s. 19)



GENNEMSTRØMNINGSDIAGRAM
(se s. 19)



RESERVEDELE (se s. 23)

- XXX = Overflade
- 000 = Krom
- 140 = Brushed Bronze
- 250 = Brushed Gold-Optic
- 300 = Polished Redgold
- 310 = Brushed Redgold
- 330 = Polished Black Chrome
- 340 = Brushed Black Chrome
- 800 = Stainless Steel Optic
- 820 = Brushed Nickel
- 830 = Polished Nickel
- 930 = Polished Brass
- 950 = Brushed Brass
- 990 = Polished Gold-Optic



RENGØRING (se s. 20)

MONTERING

(se s. 18)



△ AVISOS DE SEGURANÇA

- △ Durante a montagem devem ser utilizadas luvas de proteção, de modo a evitar ferimentos resultantes de entalamentos e de cortes.
- △ O produto só pode ser utilizado para fins de higiene pessoal.
- △ Grandes diferenças entre as pressões das águas quente e fria devem ser compensadas.

AVISOS DE MONTAGEM

- / Antes da montagem deve-se controlar o produto relativamente a danos de transporte. Após a montagem não são aceites quaisquer danos de transporte ou de superfície.
- / As tubagens e a torneira têm que ser montadas, enxaguadas e verificadas de acordo com as normas em vigor.
- / A prescrições de instalação válidas nos respetivos países devem ser respeitadas.

DADOS TÉCNICOS

Pressão de funcionamento:	max. 0,6 MPa
Pressão de func. recomendada:	0,2 - 0,4 MPa
Temperatura da água quente:	max. 60°C

DESCRIÇÃO DO SÍMBOLO



MEDIDAS (ver página 19)



FLUXOGRAMA (ver página 19)



PEÇAS DE SUBSTITUIÇÃO

- (ver página 23)
- XXX = Acabamentos
- 000 = Cromado
- 140 = Brushed Bronze
- 250 = Brushed Gold-Optic
- 300 = Polished Redgold
- 310 = Brushed Redgold
- 330 = Polished Black Chrome
- 340 = Brushed Black Chrome
- 800 = Stainless Steel Optic
- 820 = Brushed Nickel
- 830 = Polished Nickel
- 930 = Polished Brass
- 950 = Brushed Brass
- 990 = Polished Gold-Optic



LIMPEZA (ver página 20)

MONTAGEM

(ver página 18)



Δ WSKAZÓWKI BEZPIECZEŃSTWA

- Δ Aby uniknąć zranień na skutek zgniecenia lub przecięcia, podczas montażu należy nosić rękawice ochronne.
- Δ Produkt może być używany tylko do kąpieli, higieny i czyszczenia ciała.
- Δ Znaczne różnice ciśnień na dopływach ciepłej i zimnej wody muszą zostać wyrównane.

WSKAZÓWKI MONTAŻOWE

- / Przed montażem należy skontrolować produkt pod kątem szkód transportowych. Po montażu nie widać żadnych szkód transportowych ani szkód na powierzchni.
- / Przewody i armatura muszą być montowane, płukane i kontrolowane według obowiązujących norm.
- / Należy przestrzegać wytycznych instalacyjnych obowiązujących w danym kraju.

DANE TECHNICZNE

Ciśnienie robocze:	maks. 0,6 MPa
Zalecane ciśnienie robocze:	0,2 - 0,4 MPa
Temperatura wody gorącej:	maks. 60°C

OPIS SYMBOLU

WYMIARY (patrz strona 19)



SCHEMAT PRZEPŁYWU
(patrz strona 19)



CZĘŚCI SERWISOWE
(patrz strona 23)

- XXX = Kody kolorów
- 000 = Chrom
- 140 = Brushed Bronze
- 250 = Brushed Gold-Optic
- 300 = Polished Redgold
- 310 = Brushed Redgold
- 330 = Polished Black Chrome
- 340 = Brushed Black Chrome
- 800 = Stainless Steel Optic
- 820 = Brushed Nickel
- 830 = Polished Nickel
- 930 = Polished Brass
- 950 = Brushed Brass
- 990 = Polished Gold-Optic



CZYSZCZENIE (patrz strona 20)

MONTAŻ

(patrz strona 18)

**Δ BEZPEČNOSTNÍ POKYNY**

- Δ Pro zabránění řezným zraněním a pohmožděním je nutné při montáži nosit rukavice.
- Δ Produkt smí být používán pouze ke koupání a za účelem tělesné hygieny.
- Δ Je nutné vyrovnat velké rozdíly tlaku mezi přípoji studené a teplé vody.

POKYNY K MONTÁŽI

- / Před montáží je třeba produkt zkontrolovat, zda nebyl při transportu poškozen. Po zabudování nebudou uznány žádné škody způsobené transportem nebo poškození povrchu.
- / Vedení a armatura musí být namontovány, propláchnuty a otestovány podle platných norem.
- / Je třeba dodržovat montážní pravidla platná v dané zemi.

TECHNICKÉ ÚDAJE

Provozní tlak:	max. 0,6 MPa
Doporučený provozní tlak:	0,2 - 0,4 MPa
Teplota horké vody:	max. 60°C

POPIS SYMBOLŮ

ROZMĚRY (viz strana 19)



DIAGRAM PRŮTOKU (viz strana 19)



SERVISNÍ DÍLY (viz strana 23)

- XXX = Kód povrchové úpravy
- 000 = Chrom
- 140 = Brushed Bronze
- 250 = Brushed Gold-Optic
- 300 = Polished Redgold
- 310 = Brushed Redgold
- 330 = Polished Black Chrome
- 340 = Brushed Black Chrome
- 800 = Stainless Steel Optic
- 820 = Brushed Nickel
- 830 = Polished Nickel
- 930 = Polished Brass
- 950 = Brushed Brass
- 990 = Polished Gold-Optic



ČIŠTĚNÍ (viz strana 20)

MONTÁŽ

(viz strana 18)



△ BEZPEČNOSTNÉ POKYNY

- △ Pri montáži musíte nosiť rukavice, aby ste predišli pomliaždeninám a rezným poraneniam.
- △ Produkt sa smie používať len na kúpanie a telesnú hygienu.
- △ Veľké rozdiely v tlaku medzi prípojkami studenej a teplej vody musia byť vyrovnané.

POKYNY PRE MONTÁŽ

- / Pred montážou musíte produkt skontrolovať, či nebol počas transportu poškodený. Po zabudovaní nebudú uznané žiadne škody spôsobené transportom alebo poškodenia povrchu.
- / Potrubia a vybavenie musia byť namontované, prepláchnuté a vybavené v platnom normami.
- / Je potrebné dodržiavať smernice o inštalácii, ktoré sú práve teraz platné v krajinách.

TECHNICKÉ ÚDAJE

Prevádzkový tlak:	max. 0,6 MPa
Doporučený prevádzkový tlak:	0,2 - 0,4 MPa
Teplota teplej vody:	max. 60°C

POPIS SYMBOLOV

 ROZMERY (viď strana 19)

 DIAGRAM PRIETOKU (viď strana 19)

 SERVISNÉ DIELY (viď strana 23)

XXX = Farebné označenie

000 = Chróm

140 = Brushed Bronze

250 = Brushed Gold-Optic

300 = Polished Redgold

310 = Brushed Redgold

330 = Polished Black Chrome

340 = Brushed Black Chrome

800 = Stainless Steel Optic

820 = Brushed Nickel

830 = Polished Nickel

930 = Polished Brass

950 = Brushed Brass

990 = Polished Gold-Optic

 ČISTENIE (viď strana 20)

MONTÁŽ

(viď strana 18)



△ 安全技巧

- △ 装配时为避免挤压和切割受伤, 必须戴上手套。
- △ 本产品只允许作为洗浴, 卫生和洁身之用。
- △ 冷热水管间过大的压力差必须予以平衡。

安装提示

- / 安装前必须检查产品是否受到运输损害。安装后将不认可运输损害或表面损伤。
- / 管道和阀门必须根据通用标准进行安装, 冲洗和检查。
- / 请遵守当地国家现行的安装规定。

技术参数

工作压强:	最大 0,6 MPa
推荐工作压强:	0,2 - 0,4 MPa
热水温度:	最大 60°C

符号说明

 大小 (参见第页 19)

 流量示意图 (参见第页 19)

 备用零件 (参见第页 23)

XXX = 颜色代码

000 = 镀铬

140 = Brushed Bronze

250 = Brushed Gold-Optic

300 = Polished Redgold

310 = Brushed Redgold

330 = Polished Black Chrome

340 = Brushed Black Chrome

800 = Stainless Steel Optic

820 = Brushed Nickel

830 = Polished Nickel

930 = Polished Brass

950 = Brushed Brass

990 = Polished Gold-Optic



清洗 (参见第页 20)

安装

(参见第页 18)



△ УКАЗАНИЯ ПО ТЕХНИКЕ БЕЗОПАСНОСТИ

- △ Во время монтажа следует надеть перчатки во избежание прищемления и порезов.
- △ Изделие разрешается использовать только в гигиенических целях: для принятия ванны и личной гигиены.
- △ донного клапана. Перед установкой смесителя необходимо регулировочными кранами выровнять давление холодной и горячей воды при помощи вентилей регулирующих подачу воды в квартиру.

УКАЗАНИЯ ПО МОНТАЖУ

- / Перед монтажом следует проверить изделие на предмет повреждений при перевозке. После монтажа претензии о возмещении ущерба за повреждения при перевозке или повреждения поверхностей не принимаются.
- / Трубы и арматура должны быть установлены, промыты и проверены в соответствии с действующими нормами.
- / Необходимо соблюдать требования по монтажу, действующие в соответствующих странах.

ТЕХНИЧЕСКИЕ ДАННЫЕ

Рабочее давление:	не более. 0,6 МПа
Рекомендуемое рабочее давление:	0,2 - 0,4 МПа
Температура горячей воды:	не более. 60°C

ОПИСАНИЕ СИМВОЛОВ



РАЗМЕРЫ (см. стр. 19)



СХЕМА ПОТОКА (см. стр. 19)



КОМПЛЕКТ (см. стр. 23)

XXX = Цветная кодировка

000 = Хром

140 = Brushed Bronze

250 = Brushed Gold-Optic

300 = Polished Redgold

310 = Brushed Redgold

330 = Polished Black Chrome

340 = Brushed Black Chrome

800 = Stainless Steel Optic

820 = Brushed Nickel

830 = Polished Nickel

930 = Polished Brass

950 = Brushed Brass

990 = Polished Gold-Optic



ОЧИСТКА (см. стр. 20)

МОНТАЖ

(см. стр. 18)



△ TURVALLISUUSOHJEET

- △ Asennuksessa on käytettävä käsiineitä puristumien ja viiltojen aiheuttamien tapaturmien estämiseksi.
- △ Tuotetta saa käyttää ainoastaan kylpy-, hygienia- ja puhdistustarkoituksiin.
- △ Suuret paine-erot kylmä- ja kuumavesiliitäntöjen välillä on tasattava.

A SENNUSOHJEET

- / Ennen asennusta on tarkastettava tuotteen mahdolliset kuljetusvahingot. Asennuksen jälkeen kuljetus- ja pintavaurioita ei hyväksytä.
- / Putket ja hana on asennettava, huuhdeltava ja tarkastettava voimassa olevien standardien mukaisesti.
- / Jokaisessa maassa on noudatettava siellä päteviä asennusohjeita.

TEKNISET TIEDOT

Käyttöpaine:	maks. 0,6 МПа
Suositteltu käyttöpaine:	0,2 - 0,4 МПа
Kuuman veden lämpötila:	maks. 60°C

MERKIN KUVAUS



MITAT (katso sivu 19)



VIRTAUSDIAGRAMMI

(katso sivu 19)



VARAOSAT (katso sivu 23)

XXX = Värikoodaus

000 = Kromi

140 = Brushed Bronze

250 = Brushed Gold-Optic

300 = Polished Redgold

310 = Brushed Redgold

330 = Polished Black Chrome

340 = Brushed Black Chrome

800 = Stainless Steel Optic

820 = Brushed Nickel

830 = Polished Nickel

930 = Polished Brass

950 = Brushed Brass

990 = Polished Gold-Optic



PUHDISTUS (katso sivu 20)

A SENNUS

(katso sivu 18)



△ SÄKERHETSANVISNINGAR

- △ Handskar ska bäras under monteringsarbetet så att man kan undvika kläm- och skärskador.
- △ Produkten får bara användas till kroppshygien med bad och dusch.
- △ Stora tryckskillnader mellan anslutningarna för varmt och kallt vatten måste utjämnas.

MONTERINGSANVISNINGAR

- / Det måste undersökas om produkten har transportskador innan den monteras. Efter monteringen accepteras inga transport- eller ytskiktsskador.
- / Ledningarna och blandaren måste monteras, spolats igenom och kontrolleras enligt de gällande normerna.
- / De installationsriktlinjer som gäller i länderna ska följas.

TEKNISKA DATA

Driftstryck:	max. 0,6 MPa
Rek. driftstryck:	0,2 - 0,4 MPa
Varmvattentemperatur:	max. 60°C

SYMBOLFÖRKLARING



MÅTTEN (se sidan 19)



FLÖDESSCHEMA (se sidan 19)



RESERVDELAR (se sidan 23)

XXX = Färgkodning

000 = Krom

140 = Brushed Bronze

250 = Brushed Gold-Optic

300 = Polished Redgold

310 = Brushed Redgold

330 = Polished Black Chrome

340 = Brushed Black Chrome

800 = Stainless Steel Optic

820 = Brushed Nickel

830 = Polished Nickel

930 = Polished Brass

950 = Brushed Brass

990 = Polished Gold-Optic



RENGÖRING (se sidan 20)

△ SAUGUMO TECHNIKOS NURODYMAI

- △ Apsaugai nuo užspaudimo ir įsijovimo montavimo metu mūvėkite pirštines.
- △ Gaminy turi būti naudojamas tik maudymuisi, kūno higienai ir švarai palaikyti.
- △ Turi būti išlyginti šalto ir karšto slėgio nelygumai.

MONTAVIMO INSTRUKCIJA

- / Prieš montuojant būtina patikrinti, ar gaminy nebuvo pažeistas transportavimo metu. Sumontavus pretenzijos dėl transportavimo ir paviršiaus pažeidimų nepriimamos.
- / Vamzdžiai ir sujungimai turi būti montuojami, plaujami ir tikrinami pagal galiojančias normas.
- / Laikykitės atitinkamoje šalyje galiojančių direktyvų dėl įrengimo.

TECHNINIAI DUOMENYS

Darbinis slėgis:	ne daugiau kaip 0,6 MPa
Rekomenduojamas slėgis:	0,2 - 0,4 MPa
Karšto vandens temperatūra:	ne daugiau kaip 60°C

SIMBOLIO APRAŠYMAS



IŠMATAVIMAI (žr. psl. 19)



PRALAUDUMO DIAGRAMA
(žr. psl. 19)



ATSARGINĖS DALYS (žr. psl. 23)

XXX = Spalvos

000 = Chrom

140 = Brushed Bronze

250 = Brushed Gold-Optic

300 = Polished Redgold

310 = Brushed Redgold

330 = Polished Black Chrome

340 = Brushed Black Chrome

800 = Stainless Steel Optic

820 = Brushed Nickel

830 = Polished Nickel

930 = Polished Brass

950 = Brushed Brass

990 = Polished Gold-Optic



VALYMAS (žr. psl. 20)

MONTERING

(se sidan 18)



MONTAVIMAS

(žr. psl. 18)



△ SIGURNOSNE UPUTE

- △ Prilikom montaže se radi sprječavanja prignječenja i posjekotina moraju nositi rukavice.
- △ Proizvod se smije primjenjivati samo za kupanje, tuširanje i osobnu higijenu.
- △ Velika razlika u pritisku između vruće i hladne vode mora biti izbalansirana.

UPUTE ZA MONTAŽU

- / Prije montaže mora se provjeriti je li proizvod oštećen prilikom transporta. Nakon ugradnje se ne priznaju nikakve reklamacije koje se odnose na površinska i transportna oštećenja.
- / Cijevi i armatura moraju biti postavljeni, isprani i testirani prema važećim normama.
- / Obvezno se moraju uvažiti propisi o instalacijama koji vrijede u dotičnoj zemlji.

TEHNIČKI PODATCI

Najveći dopušteni tlak:	tlak 0,6 MPa
Preporučeni tlak:	0,2 - 0,4 MPa
Temperatura vruće vode:	tlak 60°C

OPIS SIMBOLA

 MJERE (pogledaj stranicu 19)

 DIJAGRAM PROTOKA (pogledaj stranicu 19)

 REZERVNI DJELOVI (pogledaj stranicu 23)

- XXX = Boje
- 000 = Krom
- 140 = Brushed Bronze
- 250 = Brushed Gold-Optic
- 300 = Polished Redgold
- 310 = Brushed Redgold
- 330 = Polished Black Chrome
- 340 = Brushed Black Chrome
- 800 = Stainless Steel Optic
- 820 = Brushed Nickel
- 830 = Polished Nickel
- 930 = Polished Brass
- 950 = Brushed Brass
- 990 = Polished Gold-Optic

 ČIŠĆENJE (pogledaj stranicu 20)

SASTAVLJANJE
(pogledaj stranicu 18)

**△ INSTRUCȚIUNI DE SIGURANȚĂ**

- △ La montare utilizați mănuși pentru evitarea contuziunilor și tăierii mâinilor.
- △ Produsul poate fi utilizat doar pentru spălarea, menținerea igienei și curățarea corpului.
- △ Diferențele de presiune mari între alimentarea cu apă rece și apă caldă trebuie echilibrate.

INSTRUCȚIUNI DE MONTARE

- / Înainte de instalare verificați, dacă produsul prezintă deteriorări de transport. După instalare garanția nu acoperă deteriorările de transport și cele de suprafață.
- / Conductele și bateriile trebuie montate, spălate și verificate conform normelor în vigoare.
- / Respectați reglementările referitoare la instalare valabile în țara respectivă.

DATE TEHNICE

Presiune de funcționare:	max. 0,6 MPa
Presiune de funcționare recomandată:	0,2 - 0,4 MPa
Temperatura apei calde:	max. 60°C

DESCRIEREA SIMBOLURILOR

 DIMENSIUNI (vezi pag. 19)

 DIAGRAMA DE DEBIT (vezi pag. 19)

 PIESE DE SCHIMB (vezi pag. 23)

- XXX = Coduri de culori
- 000 = Crom
- 140 = Brushed Bronze
- 250 = Brushed Gold-Optic
- 300 = Polished Redgold
- 310 = Brushed Redgold
- 330 = Polished Black Chrome
- 340 = Brushed Black Chrome
- 800 = Stainless Steel Optic
- 820 = Brushed Nickel
- 830 = Polished Nickel
- 930 = Polished Brass
- 950 = Brushed Brass
- 990 = Polished Gold-Optic

 CURĂȚARE (vezi pag. 20)

MONTARE
(vezi pag. 18)



ΔΥΠΟΔΕΙΞΕΙΣ ΑΣΦΑΛΕΙΑΣ

- △ Για να αποφύγετε τραυματισμούς κατά τη συναρμολόγηση πρέπει να φοράτε γάντια.
- △ Το προϊόν επιτρέπεται να χρησιμοποιείται μόνο σαν μέσο λουτρού, υγιεινής και καθαρισμού του σώματος.
- △ Οι διαφορές της πίεσης μεταξύ της σύνδεσης κρύου και ζεστού νερού θα πρέπει να αντισταθμίζονται.

ΟΔΗΓΙΕΣ ΣΥΝΑΡΜΟΛΟΓΗΣΗΣ

- / Πριν τη συναρμολόγηση πρέπει να εξεταστεί το προϊόν για ζημιές μεταφοράς. Μετά την εγκατάσταση δεν αναγνωρίζονται ζημιές από τη μεταφορά ή επιφανειακές ζημιές.
- / Οι σωλήνες και η μπαταρία πρέπει να τοποθετηθούν σύμφωνα με τα ισχύοντα πρότυπα, να τεθούν υπό πίεση και να δοκιμαστούν.
- / Θα πρέπει να τηρούνται οι οδηγίες εγκατάστασης που ισχύουν σε κάθε κράτος.

ΤΕΧΝΙΚΑ ΧΑΡΑΚΤΗΡΙΣΤΙΚΑ

Λειτουργία πίεσης:	έως 0,6 MPa
Συνιστώμενη λειτουργία πίεσης:	0,2 - 0,4 MPa
Θερμοκρασία ζεστού νερού:	έως 60°C

ΠΕΡΙΓΡΑΦΗ ΣΥΜΒΟΛΩΝ



ΔΙΑΣΤΑΣΕΙΣ (βλ. Σελίδα 19)



ΔΙΑΓΡΑΜΜΑ ΡΟΗΣ (βλ. Σελίδα 19)



ΑΝΤΑΛΛΑΚΤΙΚΑ (βλ. Σελίδα 23)

XXX = Χρώματα

000 = Επιχρωμωμένο

140 = Brushed Bronze

250 = Brushed Gold-Optic

300 = Polished Redgold

310 = Brushed Redgold

330 = Polished Black Chrome

340 = Brushed Black Chrome

800 = Stainless Steel Optic

820 = Brushed Nickel

830 = Polished Nickel

930 = Polished Brass

950 = Brushed Brass

990 = Polished Gold-Optic



ΚΑΘΑΡΙΣΜΟΣ (βλ. Σελίδα 20)

Δ VARNOSTNA OPOZORILA

- △ Pri montaži je treba nositi rokavice, da se preprečijo poškodbe zaradi zmečkanja ali urezov.
- △ Ta izdelek se sme uporabljati le z namenom umivanja, vzdrževanja higiene in telesne nege.
- △ Velike razlike v tlaku med priključkom za mrzlo in priključkom za toplo vodo je potrebno izravnati.

NAVODILA ZA MONTAŽO

- / Pred montažo je treba izdelek preveriti glede morebitnih transportnih poškodb. Po vgradnji transportne ali površinske poškodbe ne bodo več priznane.
- / Cevi in armaturo je treba montirati, izprati in preveriti po veljavnih standardih.
- / Upoštevati je treba pravilnike o inštalacijah, ki veljajo v posamezni državi.

ΤΕΧΝΙΧΝΙ ΠΟΔΑΤΚΙ

Delovni tlak:	maks. 0,6 MPa
Priporočeni delovni tlak:	0,2 - 0,4 MPa
Temperatura tople vode:	maks. 60°C

ΟΠΙΣ ΣΙΜΒΟΛΑ



MERE (glejte stran 19)



DIAGRAM PRETOKA (glejte stran 19)



REZERVNI DELI (glejte stran 23)

XXX = Barve

000 = Krom

140 = Brushed Bronze

250 = Brushed Gold-Optic

300 = Polished Redgold

310 = Brushed Redgold

330 = Polished Black Chrome

340 = Brushed Black Chrome

800 = Stainless Steel Optic

820 = Brushed Nickel

830 = Polished Nickel

930 = Polished Brass

950 = Brushed Brass

990 = Polished Gold-Optic



ČIŠČENJE (glejte stran 20)

ΣΥΝΑΡΜΟΛΟΓΗΣΗ

(βλ. Σελίδα 18)



ΜΟΝΤΑΖΑ

(glejte stran 18)



△ OHUTUSJUHISED

- △ Kandke paigaldamisel muljumis- ja löikevigastuste vältimiseks kindaid.
- △ Toodet tohib kasutada ainult pesemis-, hügieeni- ja kehahapustamiseemärkidel.
- △ Kui külma ja kuuma vee ühenduste surve on väga erinev, tuleb need tasakaalustada.

PAIGALDAMISJUHISED

- / Enne paigaldamist tuleb toodet kontrollida transpordikahjustuste osas Pärast paigaldamist ei tunnustata enam transpordi- või pinnakahjustuste kaebuseid.
- / Voolikute ja segisti paigaldamisel, loputamisel ja kontrollimisel tuleb lähtuda kehtivatest normatiividest
- / Vastavas riigis kehtivaid paigalduseeskirju tuleb järgida.

TEHNILISED ANDMED

Töörõhk

maks. 0,6 MPa

Soovitav töörõhk:

0,2 - 0,4 MPa

Kuuma vee temperatuur:

maks. 60°C

SÜMBOLITE KIRJELDUS**MÕÖTUDE** (vt lk 19)**LÄBIVOOLUDIAGRAMM** (vt lk 19)**VARUOSAD** (vt lk 23)

XXX = Värvid

000 = Kroom

140 = Brushed Bronze

250 = Brushed Gold-Optic

300 = Polished Redgold

310 = Brushed Redgold

330 = Polished Black Chrome

340 = Brushed Black Chrome

800 = Stainless Steel Optic

820 = Brushed Nickel

830 = Polished Nickel

930 = Polished Brass

950 = Brushed Brass

990 = Polished Gold-Optic

**PUHASTAMINE** (vt lk 20)**PAIGALDAMINE**

(vt lk 18)

**△ DROŠĪBAS NORĀDES**

- △ Montāžas laikā, lai izvairītos no saspiedumiem un iegriezumiem, nepieciešams nēsāt cimdus.
- △ Šo produktu drīkst izmantot tikai, lai mazgātos, higiēnai un ķermeņa tīrīšanai.
- △ Jāizlīdzina spiediena atšķirības starp aukstā un karstā ūdens pievadiem.

NORĀDĪJUMI MONTĀŽAI

- / Pirms montāžas nepieciešams pārbaudīt, vai produktam transportēšanas laikā nav radušies bojājumi. Pēc iebūvēšanas bojājumi, kas radušies transportēšanas laikā, vai virsmas bojājumi netiek atzīti.
- / Caurulvadi ar armatūra ir jāuzstāda, jāizskalo un jāpārbauda saskaņā ar spēkā esošajiem standartiem.
- / Jāievēro attiecīgās valsts spēkā esošās montāžas prasības.

TEHNISKIE DATI

Darba spiediens:

maks. 0,6 MPa

Ieteicamais darba spiediens:

0,2 - 0,4 MPa

Karstā ūdens temperatūra:

maks. 60°C

SIMBOLU NOZĪME**IZMĒRUS** (skat. lpp. 19)**CAURPLŪDES DIAGRAMMA**

(skat. lpp. 19)

**REZERVES DAĻAS** (skat. lpp. 23)

XXX = Krāsu kodi

000 = Hroma

140 = Brushed Bronze

250 = Brushed Gold-Optic

300 = Polished Redgold

310 = Brushed Redgold

330 = Polished Black Chrome

340 = Brushed Black Chrome

800 = Stainless Steel Optic

820 = Brushed Nickel

830 = Polished Nickel

930 = Polished Brass

950 = Brushed Brass

990 = Polished Gold-Optic

**TĪRĪŠANA** (skat. lpp. 20)**MONTĀŽA**

(skat. lpp. 18)



△ SIGURNOSNE NAPOMENE

- △ Prilikom montaže se radi sprečavanja prignječenja i posekotina moraju nositi rukavice.
- △ Proizvod sme da se koristi samo za kupanje, tuširanje i ličnu higijenu.
- △ Velika razlika u pritisku između vruće i hladne vode mora biti izbalansirana.

INSTRUKCIJE ZA MONTAŽU

- / Pre montaže se mora proveriti da li je proizvod oštećen pri transportu. Nakon ugradnje se ne priznaju nikakve reklamacije koje se odnose na površinska i transportna oštećenja.
- / Vodovi i armatura moraju biti postavljeni, isprani i testirani prema važećim normama.
- / Treba se pridržavati propisa koji u određenim zemljama važe za instalacije.

TEHNIČKI PODACI

Radni pritisak:	maks. 0,6 MPa
Preporučeni radni pritisak:	0,2 - 0,4 MPa
Temperatura vruće vode:	maks. 60°C

OPIS SIMBOLA



MERE (vidi stranu 19)



DIJAGRAM PROTOKA
(vidi stranu 19)



REZERVNI DELOVI (vidi stranu 23)

- XXX = Oznake boja
- 000 = Hrom
- 140 = Brushed Bronze
- 250 = Brushed Gold-Optic
- 300 = Polished Redgold
- 310 = Brushed Redgold
- 330 = Polished Black Chrome
- 340 = Brushed Black Chrome
- 800 = Stainless Steel Optic
- 820 = Brushed Nickel
- 830 = Polished Nickel
- 930 = Polished Brass
- 950 = Brushed Brass
- 990 = Polished Gold-Optic



ČIŠĆENJE (vidi stranu 20)

△ SIKKERHETSHENVISNINGER

- △ Bruk hansker under montasjen for å unngå klem- og kuttskader.
- △ Produktet skal kun brukes for bade-, hygiene- og kroppshygiene.
- △ Store trykkdifferanser mellom kaldt- og varmtvannstilkoblinger skal utlignes.

MONTAGEHENVISNINGER

- / Før montasjen skal produktet sjekkes for transportskader. Etter monteringen aksepteres ikke noen transport- eller overflateskader.
- / Ledningene og armaturen skal monteres, spyles og sjekkes iht. de gyldige normer.
- / Gjeldende retningslinjer for rørleggerarbeid i de enkelte land skal følges.

TEKNISKE DATA

Driftstrykk	maks. 0,6 MPa
Anbefalt driftstrykk:	0,2 - 0,4 MPa
Varmtvannstemperatur	maks. 60°C

SYMBOLBESKRIVELSE



MÅL (se side 19)



NNOMSTRØMNINGSDIAGRAM
(se side 19)



SERVICEDELER (se side 23)

- XXX = Fargekode
- 000 = Krom
- 140 = Brushed Bronze
- 250 = Brushed Gold-Optic
- 300 = Polished Redgold
- 310 = Brushed Redgold
- 330 = Polished Black Chrome
- 340 = Brushed Black Chrome
- 800 = Stainless Steel Optic
- 820 = Brushed Nickel
- 830 = Polished Nickel
- 930 = Polished Brass
- 950 = Brushed Brass
- 990 = Polished Gold-Optic



RENGJØRING (se side 20)

MONTAŽA

(vidi stranu 18)



MONTASJE

(se side 18)



△ УКАЗАНИЯ ЗА БЕЗОПАСНОСТ

- △ При монтажа трябва да се носят ръкавици, за да се избегнат наранявания поради притискане или порязване.
- △ Позволено е използването на продукта само за къпане, хигиена и цели на почистване на тялото.
- △ Големите разлики в налягането между изводите за студената и топлата вода трябва да се изравняват.

УКАЗАНИЯ ЗА МОНТАЖ

- / Преди монтажа продуктът трябва да се провери за транспортни щети. След монтажа не се признават транспортни или повърхностни щети.
- / Тръбопроводите и арматурата трябва да се монтира, промият и проверят в съответствие с валидните норми.
- / Трябва да бъдат спазвани валидните в съответните страни предписания за инсталиране.

ТЕХНИЧЕСКИ ДАННИ

Работно налягане:	макс. 0,6 МПа
Препоръчително работно налягане:	0,2 - 0,4 МПа
Температура на горещата вода:	макс. 60°C

ОПИСАНИЕ НА СИМВОЛИТЕ

 **РАЗМЕРИ** (вижте стр. 19)

 **ДИАГРАМА НА ПОТОКА**
(вижте стр. 19)

 **СЕРВИЗНИ ЧАСТИ** (вижте стр. 23)

- XXX = Цветово кодиране
 000 = Хром
 140 = Brushed Bronze
 250 = Brushed Gold-Optic
 300 = Polished Redgold
 310 = Brushed Redgold
 330 = Polished Black Chrome
 340 = Brushed Black Chrome
 800 = Stainless Steel Optic
 820 = Brushed Nickel
 830 = Polished Nickel
 930 = Polished Brass
 950 = Brushed Brass
 990 = Polished Gold-Optic

 **ПОЧИСТВАНЕ** (вижте стр. 20)

МОНТАЖ

(вижте стр. 18)

**△ 安全上の注意**

- △ 施工の際は手を挟んだり怪我をしないように、手袋をはめてください。
- △ この製品は、体や手を洗う等の製品本来の目的以外には使用しないでください。
- △ 給水・湯の圧力差は0.1(MPa)以内としてください。

施工上の注意

- / 製品の施工前に輸送でのダメージがないか確認してください。施工後のキズ等のお申し出はお断りさせていただきます。
- / 配管と水栓は、関連法規に従って施工、洗浄、および試験を行ってください。
- / 施工行う地域に適用される関連法規をお守りください。

技術資料

使用圧力:	最大 0,6 MPa
推奨使用水压:	0,2 - 0,4 MPa
給湯温度:	最大 60°C

アイコンの説明

 **寸法** (次のページを参照 19)

 **流量曲線図** (次のページを参照 19)

 **スペアパーツ** (次のページを参照 23)

XXX = 仕上げ色

000 = Chrome

140 = Brushed Bronze

250 = Brushed Gold-Optic

300 = Polished Redgold

310 = Brushed Redgold

330 = Polished Black Chrome

340 = Brushed Black Chrome

800 = Stainless Steel Optic

820 = Brushed Nickel

830 = Polished Nickel

930 = Polished Brass

950 = Brushed Brass

990 = Polished Gold-Optic



お手入れ方法 (次のページを参照 20)

施工方法

(次のページを参照 18)



△ UDHËZIME SIGURIE

- △ Për të evituar lëndimet e pickimeve ose të prerjeve gjatë procesit të montimit duhet që të vishni doreza.
- △ Produkti duhet të përdoret vetëm qëllimet e banjave, të higijenës dhe të larjes së trupit.
- △ Ndryshimet e mëdha të presionit mes lidhjeve të ujit të ftohtë dhe atij të ngrohtë duhen ekuilibruar.

UDHËZIME PËR MONTIMIN

- / Përpara montimit duhet që produkti të kontrollohet për dëmtime nga transporti. Pas instalimit nuk do të njihet asnjë dëmtim nga transporti ose dëmtim i sipërfaqes.
- / Tubacionet dhe rubinetet duhet që të montohen, të shpëlahen dhe të kontrollohen sipas standardeve në fuqi
- / Duhet të respektohen linjat udhëzuese të instalimit, të vlefshme për vendet respektive.

TË DHËNA TEKNIKE

Presioni gjatë punës	maks. 0,6 MPa
Presioni i rekomanduar:	0,2 - 0,4 MPa
Temperatura e ujit të ngrohtë	maks. 60°C

PËRSHKRIMI I SIMBOLIT

 PËRMASAT (shih faqen 19)



DIAGRAMI I QARKULLIMIT
(shih faqen 19)



PJESËT E SERVISIT (shih faqen 23)

XXX = Kodimi me anë të ngjyrave

000 = Krom

140 = Brushed Bronze

250 = Brushed Gold-Optic

300 = Polished Redgold

310 = Brushed Redgold

330 = Polished Black Chrome

340 = Brushed Black Chrome

800 = Stainless Steel Optic

820 = Brushed Nickel

830 = Polished Nickel

930 = Polished Brass

950 = Brushed Brass

990 = Polished Gold-Optic



PASTRIMI (shih faqen 20)

△ تنبيهات الأمان

- △ يجب إرتداء قفازات لليد أثناء التركيب لتجنب حدوث أخطار الإنحشار أو الجروح
- △ لا يجب استخدام المنتج إلا في أغراض الاستحمام والأغراض الصحية وأغراض تنظيف الجسم.
- △ يجب أن يكون تيار الماء الساخن والماء البارد متعادلين في الضغط.

تعليمات التركيب

- / قبل القيام بعملية التركيب، يجب فحص المنتج للتأكد من خلوه من أية تلفيات ناتجة عن النقل بعد القيام بعملية التركيب، لن يتم الاعتراف بوجود أية تلفيات سطحية أو تلفيات ناتجة عن عملية النقل.
- / يجب تركيب وغسيل واختبار التوصيلات وخلطات المياه طبقاً للمعايير السارية.
- / يجب مراعاة القواعد الخاصة بالتركيب وأعمال السباكة وفقاً للوائح الخاصة بكل بلد.

المواصفات الفنية

الحد الأقصى 0,6 ميجاباسكال	ضغط التشغيل:
0,2 - 0,4 ميجاباسكال	ضغط التشغيل الموصى به.
الحد الأقصى 60°C	درجة حرارة الماء الساخن:

وصف الرمز

أبعاد (راجع صفحة 19) 

رسم للصرف (راجع صفحة 19) 

قطع الغيار (راجع صفحة 23) 

الألوان = XXX

كروم = 000

Brushed Bronze = 140

Brushed Gold-Optic = 250

Polished Redgold = 300

Brushed Redgold = 310

Polished Black Chrome = 330

Brushed Black Chrome = 340

Stainless Steel Optic = 800

Brushed Nickel = 820

Polished Nickel = 830

Polished Brass = 930

Brushed Brass = 950

Polished Gold-Optic = 990

التنظيف (راجع صفحة 20) 

MONTIMI

(shih faqen 18)



التركيب

(راجع صفحة 18)



△ GÜVENLİK UYARILARI

- △ Montaj esnasında ezilme ve kesilme gibi yaralanmaları önlemek için eldiven kullanılmalıdır.
- △ Ürün yalnızca banyo, hijyen ve beden temizliği amaçları doğrultusunda kullanılabilir.
- △ Sıcak ve soğuk su bağlantıları arasında büyük basınç farklılıkları varsa, bu basınç farklılıklarının dengelenmesi gerekir.

MONTAJ AÇIKLAMALARI

- / Montaj işleminden önce ürün nakliye hasarları yönünden kontrol edilmelidir. Montaj işleminden sonra nakliye veya yüzey hasarları için sorumluluk üstlenilmemektedir.
- / Boruların ve armatürün montajı, yıkanması ve kontrolü geçerli normlara göre yapılmalıdır.
- / Ülkelerde geçerli kurulum yönetmeliklerine riayet edilmelidir.

TEKNİK BİLGİLER

İşletme basıncı:	azami 0,6 MPa
Tavsiye edilen işletme basıncı:	0,2 - 0,4 MPa
Sıcak su sıcaklığı:	azami 60°C

SİMGE AÇIKLAMASI

ÖLÇÜLERİ (bakınız sayfa 19)



AKIŞ DİYAGRAMI (bakınız sayfa 19)



YEDEK PARÇALAR (bakınız sayfa 23)

XXX = Renkler

000 = Krom

140 = Brushed Bronze

250 = Brushed Gold-Optic

300 = Polished Redgold

310 = Brushed Redgold

330 = Polished Black Chrome

340 = Brushed Black Chrome

800 = Stainless Steel Optic

820 = Brushed Nickel

830 = Polished Nickel

930 = Polished Brass

950 = Brushed Brass

990 = Polished Gold-Optic



TEMİZLEME (bakınız sayfa 20)

GARANTİ BELGESİ**ÜRETİCİ VEYA İTHALATÇI FIRMANIN**

Unvanı: Hansgrohe Armatür Ltd. Şti
 Adresi: Fulya Mahallesi Bahçeler Sokak Efe han 20/C
 Mecidiyeköy Şişli İstanbul
 Telefonu: (0-212) 273 07 30
 Faks: (0-212) 273 07 40
 web adresi: www.hansgrohe.com.tr

MALİN

Markası: Hansgrohe
 Cinsi: Sıhhi tesisat malzemesi
 Garanti Süresi: 2 YIL
 Azami Tamir Süresi: 20 İş günü

**GENEL MÜDÜR
ALBERT EMLEK**

Satıcı Firmanın:

Unvanı:

Adresi:

Telefonu:

Faks:

e-posta:

Fatura Tarih ve Sayısı:

Marka ve Modeli:

Teslim Tarihi ve Yeri:

Yetkilinin İmzası:

Firmanın Kaşesi:

**BU BÖLÜMÜ, ÜRÜNÜ ALDIĞINIZ
YETKİLİ SATICI İMZALAYACAK VE
KAŞELEYECEKTİR.**

MONTAJI

(bakınız sayfa 18)



△ BIZTONSÁGI UTASÍTÁSOK

- △ A szerelésnél a zúzódások és vágási sérülések elkerülése érdekében kesztyűt kell viselni.
- △ A terméket csak fürdéshez, mosakodáshoz, és egészségügyi tisztálkodáshoz szabad használni.
- △ A hidegvíz- és a melegvíz-csatlakozások közötti nagy nyomáskülönbséget kikell egyenlíteni!

SZERELÉSI UTASÍTÁSOK

- / A szerelés előtt ellenőrizni kell, hogy a terméknek nincs-e szállítási sérülése. Beépítés után a szállítási- vagy felületi sérüléseket nem ismerik el.
- / A vezetékeket és a csaptelepet az érvényes szabványoknak megfelelően kell felszerelni, öblíteni és ellenőrizni
- / Az egyes országokban érvényes installációs irányelveket be kell tartani.

MŰSZAKI ADATOK

Üzemi nyomás:	max. 0,6 MPa
Ajánlott üzemi nyomás:	0,2 - 0,4 MPa
Forróvíz hőmérséklet:	max. 60°C

SZIMBÓLUMOK LEÍRÁSA



MÉRETET (lásd a oldalon 19)



ÁTFOLYÁSI DIAGRAM
(lásd a oldalon 19)



TARTOZÉKOK (lásd a oldalon 23)

XXX = Színkódolás

000 = Króm

140 = Brushed Bronze

250 = Brushed Gold-Optic

300 = Polished Redgold

310 = Brushed Redgold

330 = Polished Black Chrome

340 = Brushed Black Chrome

800 = Stainless Steel Optic

820 = Brushed Nickel

830 = Polished Nickel

930 = Polished Brass

950 = Brushed Brass

990 = Polished Gold-Optic



TISZTÍTÁS (lásd a oldalon 20)

SZERELÉS

(lásd a oldalon 18)



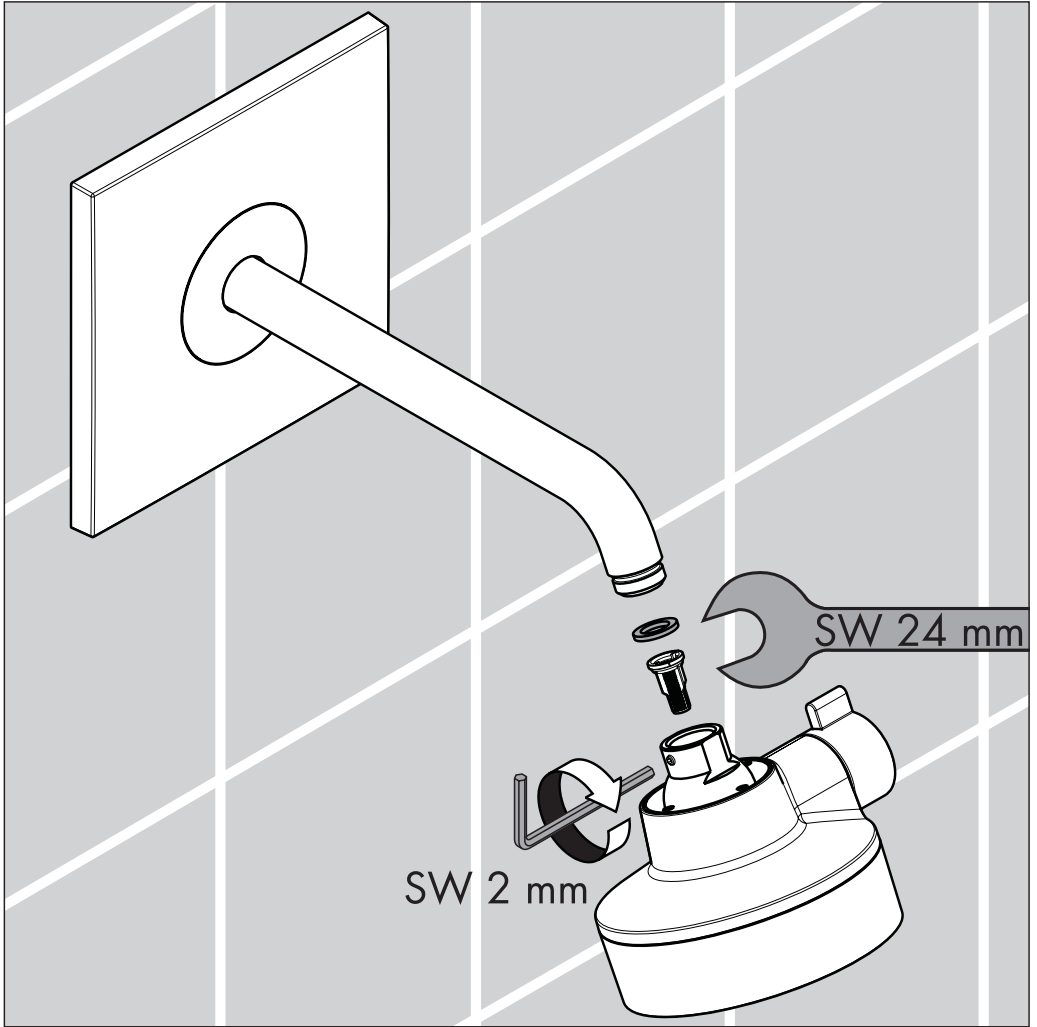

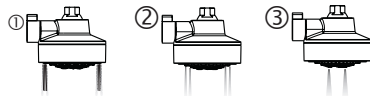
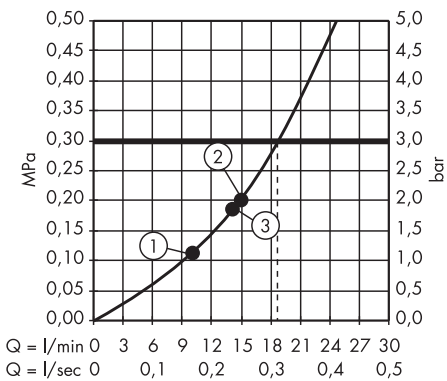
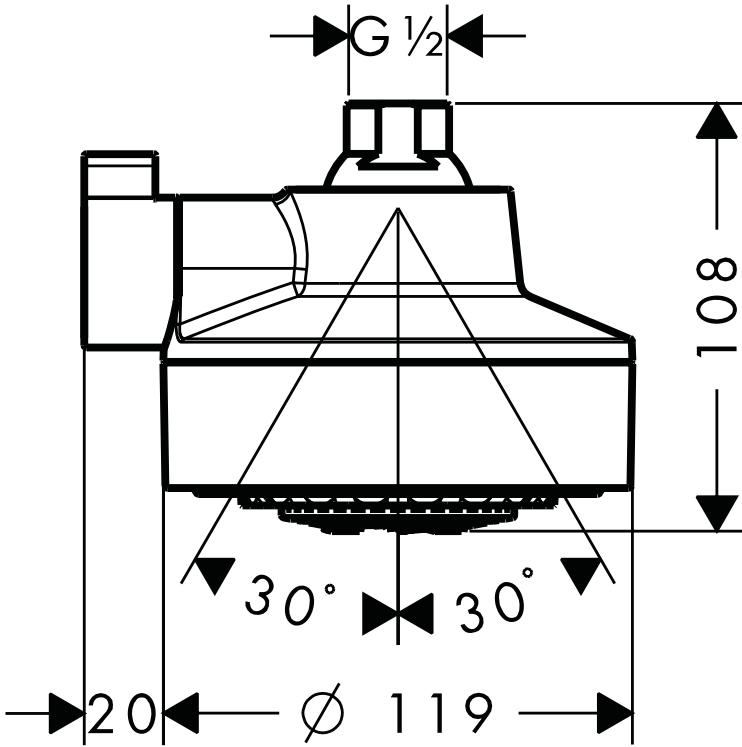



- DE / Reinigungsempfehlung / Garantie / Kontakt
FR / Recommandation pour le nettoyage / Garanties / Contact
EN / Cleaning recommendation / Warranty / Contact
IT / Raccomandazione di pulizia / Garanzia / Contatto
ES / Recomendaciones para la limpieza / Garantía / Contacto
NL / Aanbevelingen inzake reiniging / Garantie / Contact
DK / Rengøringsvejledning / Garanti / Kontakt
PT / Recomendações de limpeza / Garantia / Contacto
PL / Zalecenie dotyczące pielęgnacji / Gwarancja / Kontakt
CS / Doporučení k čištění / Záruka / Kontakt
SK / Odporúčania pre čistenie / Záruka / Kontakt
ZH / 清洁指南 / 担保 / 接触
RU / Рекомендации по очистке / Гарантия / Контакты
FI / Puhdistussuositus / Takuu / Kosketus
SV / Rengöringsrekommendationer / Garanti / Contacto
LT / Valymo rekomendacijos / Garantija / Kontaktai
HR / Preporuke za čišćenje / Garancija / Kontakt
TR / Temizleme önerisi / Garanti / Temas
RO / Recomandări pentru curățare / Garanție / Contact
EL / Σύσταση καθαρισμού / Εγγύηση / επαφή
SL / Priporočilo za čiščenje / Garancija / Kontakt
ET / Puhastussoovitused / Garantii / Kontakt
LV / Tīrīšanas ieteikumi / Garantija / Kontakti
SR / Preporuke za čišćenje / Garancija / Kontakt
NO / Anbefaling for rengjøring / Garanti / Kontakt
BG / Препоръка за почистване / Гаранция / Контакт
SQ / Këshilla rreth pastrimit / Garancia / Kontakt
KO / 세정시 권장사항 / 품질보증 / 접촉
AR / توصيات التنظيف / الضمان / اتصال
HU / Tisztítási tanácsok / Garancia / érintkezés
JP / お手入れの方法 / 保証について / ご連絡先



[www.axor-design.com/
cleaning-recommendation](http://www.axor-design.com/cleaning-recommendation)

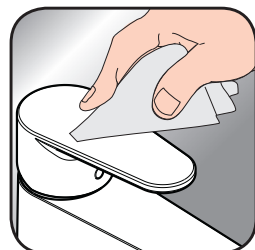

[www.axor-design.com/
cleaning-recommendation](http://www.axor-design.com/cleaning-recommendation)



[www.axor-design.com/
cleaning-recommendation](http://www.axor-design.com/cleaning-recommendation)



[www.axor-design.com/
cleaning-recommendation](http://www.axor-design.com/cleaning-recommendation)

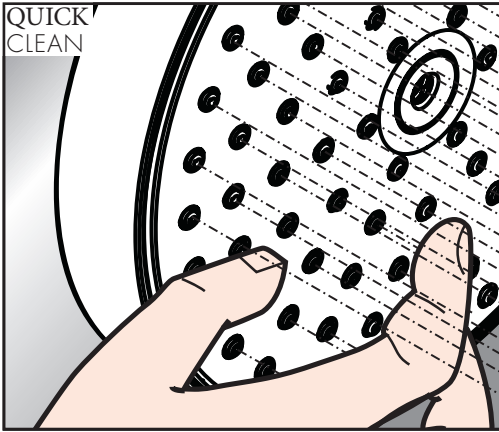

- DE / Einfach sauber: Kalk lässt sich von den Noppen ganz leicht abrubbeln.
- FR / La propreté en toute simplicité: les dépôts formés sur les buses élastiques en silicone s'éliminent par un simple passage de la main.
- EN / Just clean: simply rub over the spray nozzles to remove lime scale.
- IT / Facile da pulire: Il calcare viene eliminato semplicemente dagli ugelli elastici in silicone.
- ES / Fácil asear: La cal se puede retirar sencillamente frotando con los dedos de las toberas elásticas de silicona.
- NL / Eenvoudig schoon: Kalk kan eenvoudig van de noppen worden gewreven.
- DK / Enkel rengøring: Det er let at fjerne kalkaflejringer fra stråledyserne.
- PT / Simplesmente limpo: o calcário pode ser simplesmente retirado das saliências através de fricção.
- PL / Po prostu czysto: Pęczki można całkiem łatwo oczyścić z kamienia.
- CS / Jednoduše čistě: Vapenné usazeniny můžete z popků snadno odstranit otřením.
- SK / Jednoducho čistý: Vodný kameň sa dá zo štetín celkom ľahko odstrániť.
- ZH / 清洁: 只需要揉搓花洒表面的出水孔即可去除水垢。
- RU / Простота чистки: известь очень легко стирается с утолщений.
- FI / Yksinkertaisesti puhdas: kalkin voi helposti hieroa irti nuppystä.
- SV / Enkelt att göra rent: det är lätt att ta bort kalk från nopporna.
- LT / Paprasta švara: kalkės lengvai nugrandomos nuo kilpos.
- HR / Jednostavno čisto: Kamenac se sasvim lako uklanja s izbočina.
- TR / Sadece temiz: Kireç, düğümlemlerle kolayca ovalanabilir.
- RO / Pur și simplu curat: Calcarul se îndepărtează ușor de pe noduri prin frecare.
- EL / Απλά τέλεια καθαριότητα: Τα άλατα μπορούν να αφαιρεθούν με μεγάλη ευκολία από τα στόμια.
- SL / Preprosto čisto: arnenec se z lahkoto podrgne z vozličkov.
- ET / Lihtsalt puhas: lujja saab nuppudelt lihtsalt maha hõõruda.
- LV / Vienkārša tīrīšana: kaļķis no izvīrzījumiem ir viegli norubināms.
- SR / Jednostavno čisto: Kamenac se sasvim lako skida sa izbočina.
- NO / Simpelt ren: Ved å gnikke er det lett å fjerne kalk fra nuppene.
- BG / Просто чисто: Варовикът лесно може да се изтърси от удебеленията.
- SQ / Thjesht dhe pastër. Mbetjet gëlqerore mund të hiqen me fërkim të lehtë.
- AR / إنه سهل التنظيف، حيث يسقط الجير بسهولة شديدة من الأجزاء الناتئة
- HU / Egyszerűen tisztá: a vízkő egészen könnyen ledörzsölhető a csomókról.
- JP / 清掃が簡単: カルキは突起部から簡単にこすり落とすことができます。

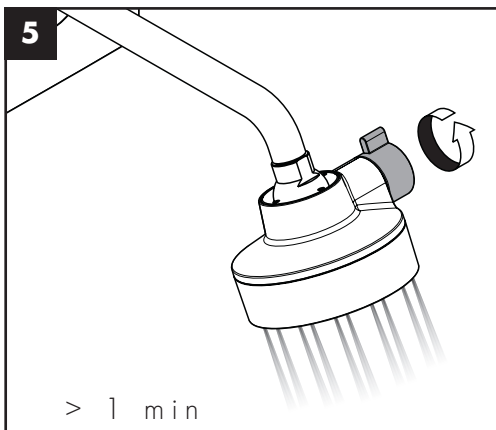
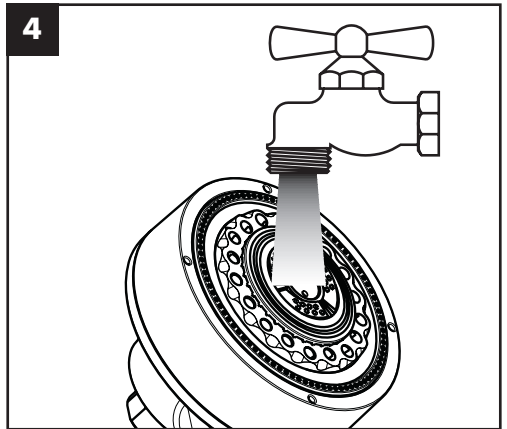
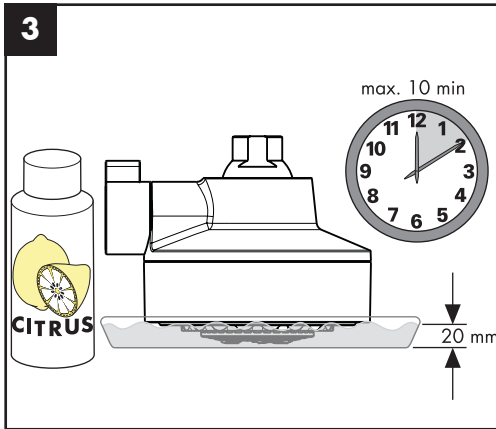
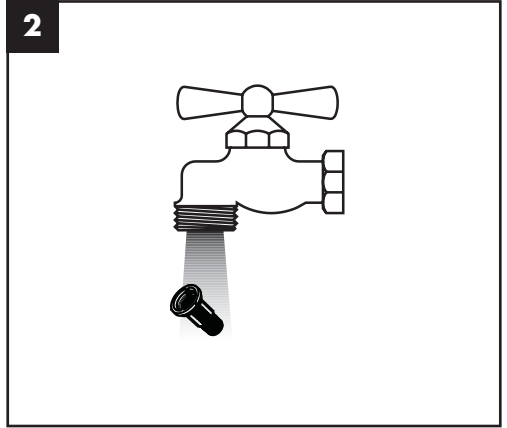
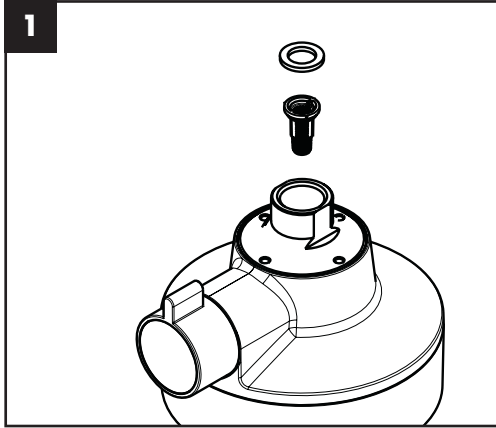

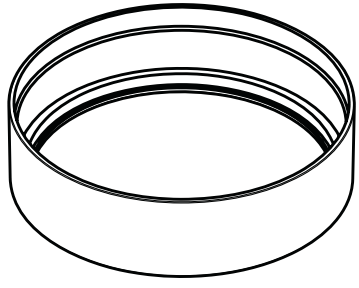
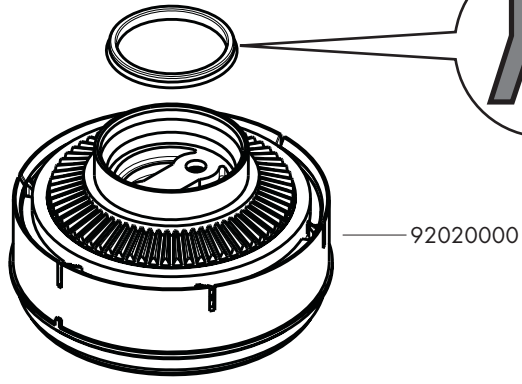
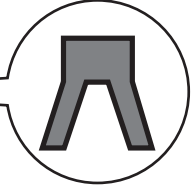
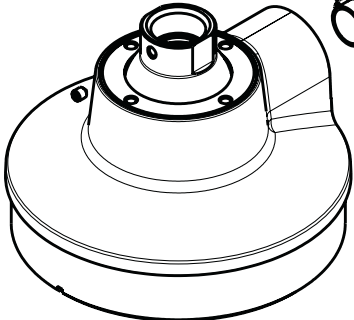
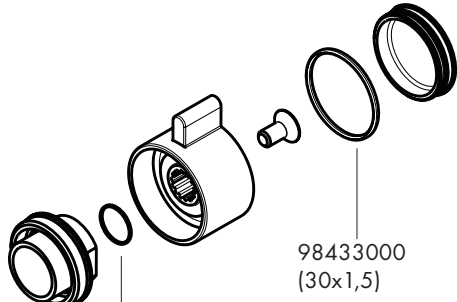
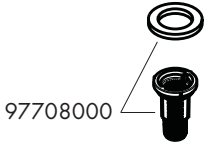

AXOR

AXOR / Hansgrohe SE
Austraße 5-9
77761 Schiltach
Deutschland

info@axor-design.com
axor-design.com

06/2022
9.01336.03